

ECMA

Standardizing Information and Communication Systems

**Private Integrated Services Network
(PISN) -
Specification, Functional Model and
Information Flows -
Wireless Terminal Call Handling
Additional Network Features**



Standardizing Information and Communication Systems

**Private Integrated Services Network
(PISN) -
Specification, Functional Model and
Information Flows -
Wireless Terminal Call Handling
Additional Network Features**

(WTMCH-SD)

Brief History

This Standard is one of a series of ECMA Standards defining Wireless Terminal Mobility (WTM) services and signalling protocols applicable to Private Integrated Services Networks (PISNs). The series uses ISDN concepts as developed by ITU-T and conforms to the framework of International Standards for Open Systems Interconnection as defined by ISO/IEC. It is based on early work by ETSI.

This particular Standard specifies the Wireless Terminal Call Handling additional network feature.

This Standard is based upon the practical experience of ECMA member companies and the results of their active and continuous participation in the work of ISO/IEC JTC1, ITU-T, ETSI and other international and national standardization bodies. It represents a pragmatic and widely based consensus.

This ECMA Standard is in complete alignment with International Standard ISO/IEC 15430:1999(E) published by ISO/IEC in September 1999.

This ECMA Standard has been adopted by the General Assembly of June 2000.

Table of contents

1	Scope	1
2	Conformance	1
3	References (normative)	1
4	Terms and definitions	2
4.1	External definitions	2
4.2	Other definitions	3
4.2.1	WTM call	3
4.2.2	WTMI user	3
4.2.3	WTMO user	3
4.2.4	Incoming WTM call	3
4.2.5	Outgoing WTM call	3
5	Symbols and abbreviated terms	3
6	ANF-WTMI stage 1 specification	4
6.1	Description	4
6.1.1	General description	4
6.1.2	Qualifications on applicability to telecommunication services	4
6.2	Procedures	4
6.2.1	Provision/withdrawal	4
6.2.2	Normal procedures	4
6.2.3	Exceptional procedures	4
6.3	Interaction with other supplementary services and ANFs	4
6.3.1	Calling Line Identification Presentation (SS-CLIP)	4
6.3.2	Connected Line Identification Presentation (SS-COLP)	4
6.3.3	Calling/Connected Line Identification Restriction (SS-CLIR)	4
6.3.4	Calling Name Identification Presentation (SS-CNIP)	5
6.3.5	Connected Name Identification Presentation (SS-CONP)	5
6.3.6	Calling/Connected Name Identification Restriction (SS-CNIR)	5
6.3.7	Call Completion to Busy Subscriber (SS-CCBS)	5
6.3.8	Call Completion on No Reply (SS-CCNR)	5
6.3.9	Call Transfer (SS-CT)	5
6.3.10	Call Forwarding Unconditional (SS-CFU)	5
6.3.11	Call Forwarding Busy (SS-CFB)	5
6.3.12	Call Forwarding No Reply (SS-CFNR)	5
6.3.13	Call Deflection (SS-CD)	5
6.3.14	Path Replacement (ANF-PR)	5
6.3.15	Call Offer (SS-CO)	5
6.3.16	Call Intrusion (SS-CI)	5
6.3.17	Do Not Disturb (SS-DND)	5

6.3.18	Do Not Disturb Override (SS-DNDO)	5
6.3.19	Advice of Charge (SS-AOC)	5
6.3.20	Recall (SS-RE)	5
6.3.21	Call Interception (ANF-CINT)	5
6.3.22	Transit Counter (ANF-TC)	6
6.3.23	Route Restriction Class (ANF-RRC)	6
6.3.24	Message Waiting Indication (SS-MWI)	6
6.3.25	Wireless Terminal Location Registration (SS-WTLR)	6
6.3.26	Wireless Terminal Information (ANF-WTINFO)	6
6.3.27	Wireless Terminal Outgoing Call (ANF-WTMO)	6
6.3.28	Authentication of Wireless Terminal (SS-WTAT)	6
6.3.29	Authentication of Network (SS-WTAN)	6
6.4	Interworking considerations	6
6.5	Overall SDL	6
7	ANF-WTMO stage 1 specification	7
7.1	Description	7
7.1.1	General description	7
7.1.2	Qualifications on applicability to telecommunication services	7
7.2	Procedures	7
7.2.1	Provision/withdrawal	7
7.2.2	Normal procedures	7
7.2.3	Exceptional procedures	8
7.3	Interaction with other supplementary services and ANFs	8
7.3.1	Calling Line Identification Presentation (SS-CLIP)	8
7.3.2	Connected Line Identification Presentation (SS-COLP)	8
7.3.3	Calling/Connected Line Identification Restriction (SS-CLIR)	8
7.3.4	Calling Name Identification Presentation (SS-CNIP)	8
7.3.5	Connected Name Identification Presentation (SS-CONP)	8
7.3.6	Calling/Connected Name Identification Restriction (SS-CNIR)	8
7.3.7	Call Completion to Busy Subscriber (SS-CCBS)	9
7.3.8	Call Completion on No Reply (SS-CCNR)	9
7.3.9	Call Transfer (SS-CT)	9
7.3.10	Call Forwarding Unconditional (SS-CFU)	9
7.3.11	Call Forwarding Busy (SS-CFB)	9
7.3.12	Call Forwarding No Reply (SS-CFNR)	9
7.3.13	Call Deflection (SS-CD)	9
7.3.14	Path Replacement (ANF-PR)	9
7.3.15	Call Offer (SS-CO)	9
7.3.16	Call Intrusion (SS-CI)	9
7.3.17	Do Not Disturb (SS-DND)	9
7.3.18	Do Not Disturb Override (SS-DNDO)	9
7.3.19	Advice of Charge (SS-AOC)	9
7.3.20	Recall (SS-RE)	9
7.3.21	Call Interception (ANF-CINT)	9
7.3.22	Transit Counter (ANF-TC)	9

7.3.23	Route Restriction Class (ANF-RRC)	9
7.3.24	Message Waiting Indication (SS-MWI)	9
7.3.25	Wireless Terminal Location Registration (SS-WTLR)	9
7.3.26	Wireless Terminal Information (ANF-WTINFO)	9
7.3.27	Wireless Terminal Incoming Call (ANF-WTMI)	10
7.3.28	Authentication of Wireless Terminal (SS-WTAT)	10
7.3.29	Authentication of Network (SS-WTAN)	10
7.4	Interworking considerations	10
7.5	Overall SDL	10
8	ANF-WTMI stage 2 specification	11
8.1	Functional model	11
8.1.1	Functional model description	11
8.1.2	Description of functional entities	11
8.1.3	Relationship of functional model to basic call functional model	12
8.2	Information flows	12
8.2.1	Definition of information flows	12
8.2.2	Relationship of information flows to basic call information flows	14
8.2.3	Examples of information flow sequences	14
8.3	Functional entity actions	17
8.3.1	Functional entity actions of FE1	17
8.3.2	Functional entity actions of FE2	17
8.3.3	Functional entity actions of FE3	17
8.3.4	Functional entity actions of FE4	17
8.3.5	Functional entity actions of FE5	17
8.4	Functional entity behaviour	17
8.4.1	Behaviour of FE1	18
8.4.2	Behaviour of FE2	19
8.4.3	Behaviour of FE3	20
8.4.4	Behaviour of FE4	21
8.4.5	Behaviour of FE5	22
8.5	Allocation of functional entities to physical equipment	22
8.6	Interworking considerations	23
9	ANF-WTMO stage 2 specification	23
9.1	Functional model	23
9.1.1	Functional model description	23
9.1.2	Description of functional entities	24
9.1.3	Relationship of functional model to basic call functional model	24
9.2	Information flows	24
9.2.1	Definition of information flows	24
9.2.2	Relationship of information flows to basic call information flows	25
9.2.3	Examples of information flow sequences	25
9.3	Functional entity actions	27
9.3.1	Functional entity actions of FE1	27
9.3.2	Functional entity actions of FE2	27

9.3.3	Functional entity actions of FE3	27
9.4	Functional entity behaviour	28
9.4.1	Behaviour of FE1	28
9.4.2	Behaviour of FE2	29
9.4.3	Behaviour of FE3	30
9.5	Allocation of functional entities to physical equipment	30
9.6	Interworking considerations	30

1 Scope

This Standard specifies the Wireless terminal call handling additional network features (ANF-WTMI, ANF-WTMO), which are applicable to various basic services supported by Private Integrated Services Networks (PISN). Basic services are specified in ECMA-142.

Additional network feature Wireless terminal incoming call (ANF-WTMI) directs incoming calls to a WTMI user within a PISN regardless of the WTMI user's geographical location within the PISN, provided the WTMI user's location is known.

Additional network feature Wireless terminal outgoing call (ANF-WTMO) detects an outgoing call from a WTMO user and establishes it as a basic call, regardless of the user's geographical location within the PISN. It also provides the WTMO user's service profile for use by outgoing call control, or alternatively passes the call to the WTMO user's home location for processing.

Service specifications are produced in three stages, according to the method described in CCITT Recommendation I.130. This Standard contains the stage 1 and stage 2 specifications of ANF-WTMI and ANF-WTMO. The stage 1 specification (clauses 6 and 7) specifies the service as seen by users of PISNs. The stage 2 specification (clauses 8 and 9) identifies the functional entities involved in the service and the information flows between them.

2 Conformance

In order to conform to this Standard, a stage 3 Standard shall specify signalling protocols and equipment behaviour that are capable of being used in a PISN which supports the services specified in this Standard. This means that, to claim conformance, a stage 3 Standard is required to be adequate for the support of those aspects of clauses 6 and 7 (stage 1) and clauses 8 and 9 (stage 2) which are relevant to the interface or equipment to which the stage 3 Standard applies.

3 References (normative)

The following standards contain provisions which, through reference in this text, constitute provisions of this Standard. All standards are subject to revision, and parties to agreements based on this Standard are encouraged to investigate the possibility of applying the most recent editions of the standards indicated below.

In the case of references to ECMA Standards that are aligned with ISO/IEC International Standards, the number of the appropriate ISO/IEC International Standard is given in brackets after the ECMA reference.

ECMA-133	Private Integrated Services Network (PISN) - Reference Configuration for PISN Exchanges (PINX) (International Standard ISO/IEC 11579-1)
ECMA-142	Private Integrated Services Network (PISN) - Circuit Mode 64kbit/s Bearer Services - Service Description, Functional Capabilities and Information Flows (International Standard ISO/IEC 11574)
ECMA-155	Private Integrated Services Networks - Addressing (International Standard ISO/IEC 11571)
ECMA-173	Private Integrated Services Network (PISN) - Specification, Functional Model and Information Flows - Call Diversion Supplementary Services (International Standard ISO/IEC 13872)
ECMA-224	Private Integrated Services Network (PISN) - Specification, Functional Model and Information Flows - Transit Counter Additional Network Feature (International Standard ISO/IEC 15055)
ECMA-301	Private Integrated Services Network (PISN) - Specification, Functional Model and Information Flows - Wireless Terminal Location Registration Supplementary Service and Wireless Terminal Information Exchange Additional Network Feature (International Standard ISO/IEC 15428)

ECMA-305	Private Integrated Services Network (PISN) - Specification, Functional Model and Information Flows - Wireless Terminal Authentication Supplementary Services (International Standard ISO/IEC 15432)
ISO/IEC 13242	Information technology - Telecommunications and information exchange between systems - Private Integrated Services Network - Specification, functional model and information flows - Route Restriction Class additional network feature (1997)
ITU-T Rec. I.112	Vocabulary of terms for ISDNs (1993)
CCITT Rec. I.130	Method for the characterization of telecommunication services supported by an ISDN and network capabilities of an ISDN (Blue Book) (1988)
ITU-T Rec. I.210	Principles of telecommunication services supported by an ISDN and the means to describe them (1993)
ITU-T Rec. Z.100	Specification and description language (1993)

4 Terms and definitions

For the purposes of this Standard, the following definitions apply.

4.1 External definitions

This Standard uses the following terms defined in other documents:

- Address	(ECMA-155)
- Additional network feature (ANF)	(ECMA-301)
- Basic service	(ITU-T Rec. I.210)
- Call, basic call	(ECMA-142)
- Complete (PISN) number	(ECMA-155)
- Fixed part (FP)	(ECMA-301)
- Home data base (HDB)	(ECMA-301)
- Home PINX	(ECMA-301)
- Number, PISN number	(ECMA-155)
- Partial (PISN) number	(ECMA-155)
- Private Integrated Services Network (PISN)	(ECMA-133)
- Private Integrated Services Network Exchange (PINX)	(ECMA-133)
- Route access class (RAC)	(ISO/IEC 13242)
- Service	(ITU-T Rec. I.112)
- Service profile	(ECMA-301)
- Signalling	(ITU-T Rec. I.112)
- Supplementary Service	(ITU-T Rec. I.210)
- User	(ECMA-142)
- Visitor data base (VDB)	(ECMA-301)
- Visitor PINX	(ECMA-301)
- Wireless Terminal Mobility (WTM)	(ECMA-301)

This Standard refers to the following basic call functional entities (FEs) defined in ECMA-142:

- Call Control (CC)
- Call Control Agent (CCA).

This Standard refers to the following basic call inter-FE relationships defined in ECMA-142:

- r1
- r2
- r3

This Standard refers to the following basic call information flows defined in ECMA-142:

- RELEASE request/indication
- SETUP request/indication
- SETUP response/confirmation
- SETUP REJECT request/indication.

This Standard refers to the following basic call information flow service elements defined in ECMA-142:

- Call History
- Connection Type
- Destination Number
- Destination Subaddress
- Originating Number
- Originating Subaddress.

4.2 Other definitions

4.2.1 WTM call

A call which is processed by ANF-WTMI or ANF-WTMO.

4.2.2 WTMI user

A user whose incoming calls are processed by ANF-WTMI.

4.2.3 WTMO user

A user whose outgoing calls are processed by ANF-WTMO.

4.2.4 Incoming WTM call

A call whose called user is a WTMI user.

4.2.5 Outgoing WTM call

A call whose calling user is a WTMO user.

5 Symbols and abbreviated terms

ANF	Additional Network feature
ANF-WTMI	ANF Wireless TerMinal Incoming call
ANF-WTMO	ANF Wireless TerMinal Outgoing call
CC	Call Control (functional entity)
CCA	Call Control Agent (functional entity)
FE	Functional Entity
FP	Fixed Part
HDB	Home Data Base
ISDN	Integrated Services Digital Network
PINX	Private Integrated Services Network Exchange
PISN	Private Integrated Services Network

RAC	Route Access Class
SDL	Specification and Description Language
SS	Supplementary Service
VDB	Visitor Data Base
WTM	Wireless Terminal Mobility

6 ANF-WTMI stage 1 specification

6.1 Description

6.1.1 General description

ANF-WTMI enables calls to be directed to a WTMI user within the PISN. As there is no predetermined access for the connection of a WTMI user to the PISN, the directing of such calls requires that information regarding the location of the WTMI user is available.

6.1.2 Qualifications on applicability to telecommunication services

ANF-WTMI is applicable to all basic services defined in ECMA-142.

6.2 Procedures

6.2.1 Provision/withdrawal

Not applicable

6.2.2 Normal procedures

6.2.2.1 Activation/deactivation/registration/interrogation

ANF-WTMI shall be permanently activated.

Registration and interrogation are not applicable to this ANF.

6.2.2.2 Invocation and operation

For each WTMI user, information shall be maintained relating to the location of the WTMI user within the PISN.

ANF-WTMI shall be invoked for an incoming call when analysis of the destination number indicates that the called user is a WTMI user. Once invoked, ANF-WTMI shall route the call to the WTMI user using the destination number to determine the address of the PISN access currently in use by the WTMI user.

Further processing of the call shall follow normal basic call procedures.

6.2.3 Exceptional procedures

6.2.3.1 Activation/deactivation/registration/interrogation

Not applicable

6.2.3.2 Invocation and operation

If the PISN is unable to complete an incoming call to a WTMI user, an indication that the call was unsuccessful shall be sent to the calling user. Normal basic call failure procedures shall be used.

6.3 Interaction with other supplementary services and ANFs

Interactions with other supplementary services and ANFs for which PISN Standards were available at the time of publication of this Standard are specified below.

6.3.1 Calling Line Identification Presentation (SS-CLIP)

No interaction.

6.3.2 Connected Line Identification Presentation (SS-COLP)

No interaction.

6.3.3 Calling/Connected Line Identification Restriction (SS-CLIR)

No interaction.

6.3.4 Calling Name Identification Presentation (SS-CNIP)

No interaction.

6.3.5 Connected Name Identification Presentation (SS-CONP)

No interaction.

6.3.6 Calling/Connected Name Identification Restriction (SS-CNIR)

No interaction.

6.3.7 Call Completion to Busy Subscriber (SS-CCBS)

No interaction.

6.3.8 Call Completion on No Reply (SS-CCNR)

No interaction.

6.3.9 Call Transfer (SS-CT)

No interaction.

6.3.10 Call Forwarding Unconditional (SS-CFU)

If SS-CFU has been activated, the invocation of SS-CFU shall take precedence over the directing of calls by means of ANF-WTMI.

6.3.11 Call Forwarding Busy (SS-CFB)

No interaction.

NOTE

SS-CFB may not be available to the WTMI user.

6.3.12 Call Forwarding No Reply (SS-CFNR)

No interaction.

NOTE

SS-CFNR may not be available to the WTMI user.

6.3.13 Call Deflection (SS-CD)

No interaction.

6.3.14 Path Replacement (ANF-PR)

No interaction.

6.3.15 Call Offer (SS-CO)

No interaction.

6.3.16 Call Intrusion (SS-CI)

No interaction.

6.3.17 Do Not Disturb (SS-DND)

No interaction.

6.3.18 Do Not Disturb Override (SS-DNDO)

No interaction.

6.3.19 Advice of Charge (SS-AOC)

No interaction.

6.3.20 Recall (SS-RE)

No interaction.

6.3.21 Call Interception (ANF-CINT)

No interaction.

NOTE

Failure of ANF-WTMI can be a cause for invoking ANF-CINT.

6.3.22 Transit Counter (ANF-TC)

ANF-TC may apply to the redirected call to the WTMI user.

6.3.23 Route Restriction Class (ANF-RRC)

Either the calling user's RAC or the WTMI user's RAC shall be used.

6.3.24 Message Waiting Indication (SS-MWI)

A message waiting indication for the WTMI user shall be directed to the visited location.

6.3.25 Wireless Terminal Location Registration (SS-WTLR)

An incoming call to a WTMI user may be rejected if it occurs while SS-WTLR is invoked or if the WTMI user is in the deregistered state.

NOTE

ANF-WTMI requires that SS-WTLR has been invoked for the WTMI user at that location.

6.3.26 Wireless Terminal Information (ANF-WTINFO)

No interaction.

6.3.27 Wireless Terminal Outgoing Call (ANF-WTMO)

No interaction.

6.3.28 Authentication of Wireless Terminal (SS-WTAT)

ANF-WTMI may cause the invocation of SS-WTAT.

6.3.29 Authentication of Network (SS-WTAN)

No interaction.

6.4 Interworking considerations

No specific requirements.

6.5 Overall SDL

Figure 1 contains the dynamic description of ANF-WTMI using the Specification and Description Language (SDL) defined in ITU-T Rec. Z.100. The SDL process represents the behaviour of the PISN in providing ANF-WTMI. Input and output signals represent stimuli from/to basic call control.

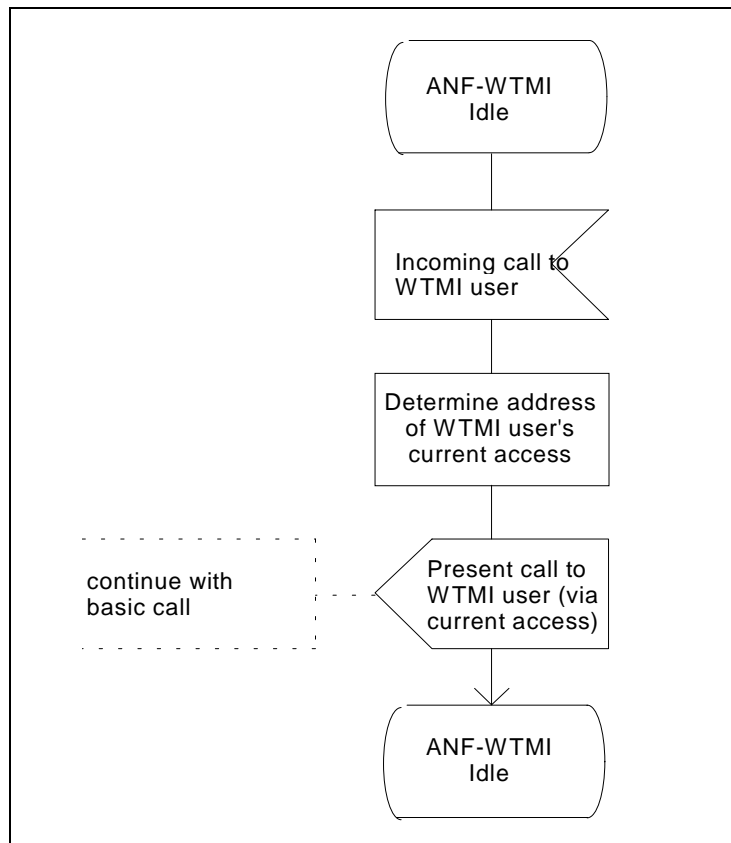

Figure 1 - ANF-WTMI, overall SDL

7 ANF-WTMO stage 1 specification

7.1 Description

7.1.1 General description

ANF-WTMO permits the PISN to verify the identity of a WTMO user when it initiates a call from its current visited location. ANF-WTMO also provides access to the WTMO user's service profile for use by outgoing call control, or alternatively, passes the call to the WTMO user's home location for processing.

7.1.2 Qualifications on applicability to telecommunication services

ANF-WTMO is applicable to all basic services defined in ECMA-142.

7.2 Procedures

7.2.1 Provision/withdrawal

Not applicable.

7.2.2 Normal procedures

7.2.2.1 Activation/deactivation/registration/interrogation

ANF-WTMO shall be permanently activated.

Registration and interrogation are not applicable to this ANF.

7.2.2.2 Invocation and operation

ANF-WTMO is an extension of basic call control which replaces certain procedures that basic call control is unable to perform satisfactorily for WTMO users. It may be invoked when a call request is recognised as being initiated by a WTMO user.

NOTE 1

The PISN need not invoke ANF-WTMO on all outgoing calls. Examples of when it might not be invoked are:

- *when applying a fixed service profile to all WTMO users;*
- *when allowing outgoing WTM calls without prior location registration.*

If ANF-WTMO is invoked, the PISN shall verify that the WTMO user is registered as a visiting user, and if so, set the originating number to the complete PISN number of the WTMO user, unless it is already that.

NOTE 2

Positive identification does not guarantee that the WTMO user's identity is actually the one claimed to be; this additional validation would be part of supplementary service SS-WTAT.

ANF-WTMO shall then make the WTMO user's service profile available for use by outgoing call control, with further call establishment following normal basic call procedures. Alternatively, the call may be processed at the WTMO user's home location.

NOTE 3

The criteria to be used in determining whether the call should be processed locally or at the home location are beyond the scope of this Standard but could include the following:

- *service not supported at visitor location;*
- *all outgoing WTM calls are processed at the home location;*
- *service profile details not complete at visitor location.*

7.2.3 Exceptional procedures

7.2.3.1 Activation/deactivation/registration/interrogation

Not applicable.

7.2.3.2 Invocation and operation

The PISN may reject the call request with an appropriate failure indication for any of the following reasons:

- no originating number provided;
- the indicated WTMO user is not registered at that location area.

Furthermore, all restrictions and exceptional procedures for basic call establishment shall apply.

7.3 Interaction with other supplementary services and ANFs

Interactions with other supplementary services and ANFs for which PISN Standards were available at the time of publication of this Standard are specified below.

7.3.1 Calling Line Identification Presentation (SS-CLIP)

No interaction.

7.3.2 Connected Line Identification Presentation (SS-COLP)

No interaction.

7.3.3 Calling/Connected Line Identification Restriction (SS-CLIR)

No interaction.

7.3.4 Calling Name Identification Presentation (SS-CNIP)

No interaction.

7.3.5 Connected Name Identification Presentation (SS-CONP)

No interaction.

7.3.6 Calling/Connected Name Identification Restriction (SS-CNIR)

No interaction.

- 7.3.7 Call Completion to Busy Subscriber (SS-CCBS)**
No interaction.
- 7.3.8 Call Completion on No Reply (SS-CCNR)**
No interaction.
- 7.3.9 Call Transfer (SS-CT)**
No interaction.
- 7.3.10 Call Forwarding Unconditional (SS-CFU)**
No interaction.
- 7.3.11 Call Forwarding Busy (SS-CFB)**
No interaction.
- 7.3.12 Call Forwarding No Reply (SS-CFNR)**
No interaction.
- 7.3.13 Call Deflection (SS-CD)**
No interaction.
- 7.3.14 Path Replacement (ANF-PR)**
No interaction.
- 7.3.15 Call Offer (SS-CO)**
No interaction.
- 7.3.16 Call Intrusion (SS-CI)**
No interaction.
- 7.3.17 Do Not Disturb (SS-DND)**
No interaction.
- 7.3.18 Do Not Disturb Override (SS-DNDO)**
No interaction.
- 7.3.19 Advice of Charge (SS-AOC)**
No interaction.
- 7.3.20 Recall (SS-RE)**
No interaction.
- 7.3.21 Call Interception (ANF-CINT)**
No interaction.
- 7.3.22 Transit Counter (ANF-TC)**
ANF-TC may apply for an outgoing call. The transit counter value may be reset at the home location.
- 7.3.23 Route Restriction Class (ANF-RRC)**
No interaction.
- 7.3.24 Message Waiting Indication (SS-MWI)**
No interaction.
- 7.3.25 Wireless Terminal Location Registration (SS-WTLR)**
No interaction.
NOTE
ANF-WTMO may require that SS-WTLR has been invoked for the WTMO user at that location.
- 7.3.26 Wireless Terminal Information (ANF-WTINFO)**
No interaction.

7.3.27 Wireless Terminal Incoming Call (ANF-WTMI)

No interaction.

7.3.28 Authentication of Wireless Terminal (SS-WTAT)

ANF-WTMO may cause the invocation of SS-WTAT.

7.3.29 Authentication of Network (SS-WTAN)

No interaction.

7.4 Interworking considerations

No specific requirements.

7.5 Overall SDL

Figure 2 contains the dynamic description of ANF-WTMO using the Specification and Description Language (SDL) defined in ITU-T Rec. Z.100. The SDL process represents the behaviour of the PISN in providing ANF-WTMO. Input and output signals represent stimuli from/to basic call control.

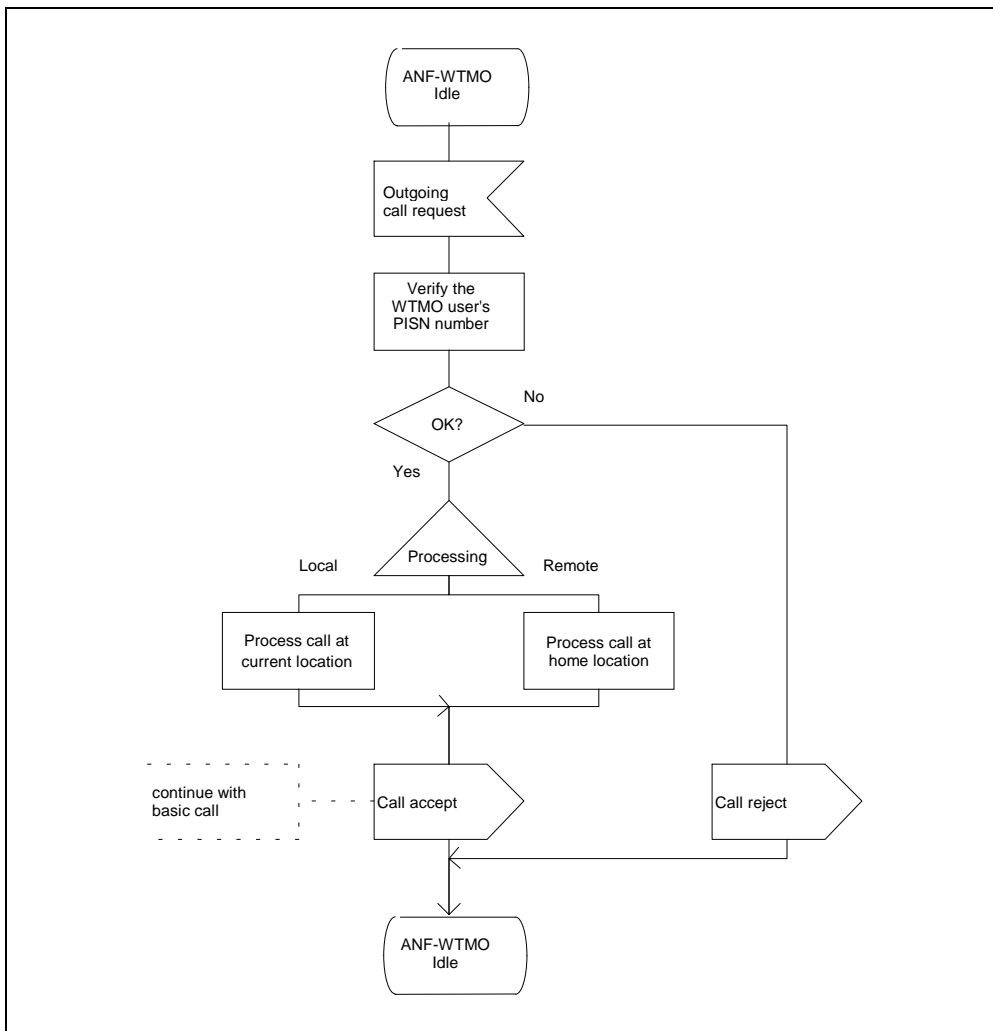

Figure 2 - ANF-WTMO, overall SDL

8 ANF-WTMI stage 2 specification

8.1 Functional model

8.1.1 Functional model description

The functional model shall comprise the following functional entities:

- FE1: Incoming WTM call execution;
- FE2: Incoming WTM call detection and control;
- FE3: Routing information provision;
- FE4: Visited location control and execution;
- FE5: WTM service access agent.

The following functional relationships shall exist between these FEs:

- ra: between FE1 and FE2;
- rb: between FE2 and FE3;
- rc: between FE1 and FE4 and between FE4 and FE5.

Figure 3 shows these FEs and relationships.

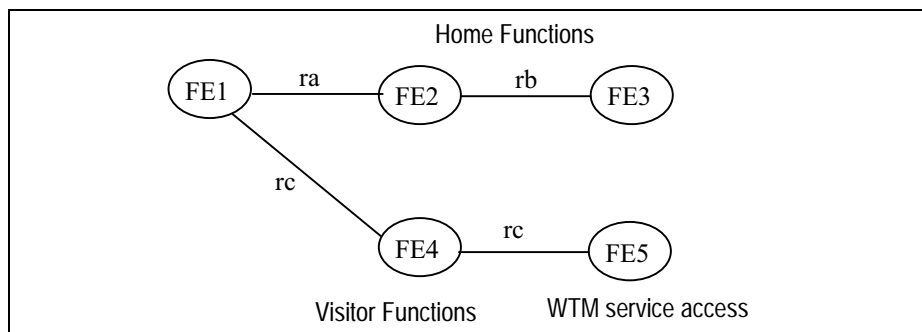

Figure 3 - Functional model for ANF-WTMI

8.1.2 Description of functional entities

8.1.2.1 Incoming WTM call execution, FE1

On request from FE2, this FE directs an incoming call to the WTMI user by initiating call establishment towards the WTMI user's location and passing the WTMI user's identity.

8.1.2.2 Incoming WTM call detection and control, FE2

This FE detects an incoming call to a WTMI user and requests FE1 to redirect the call to the WTMI user's location on the basis of information obtained from FE3.

8.1.2.3 Routing information provision, FE3

This FE provides details of the WTMI user's location within the PISN to FE2 on request.

8.1.2.4 Visited location control and execution, FE4

This FE detects the incoming call and directs it to the WTMI user's indicated PISN access.

8.1.2.5 WTM service access agent, FE5

This FE extends the incoming call to the appropriate WTMI user using the identity provided by FE4.

8.1.3 Relationship of functional model to basic call functional model

Figure 4 shows an example of the relationship between the functional model and a basic call.

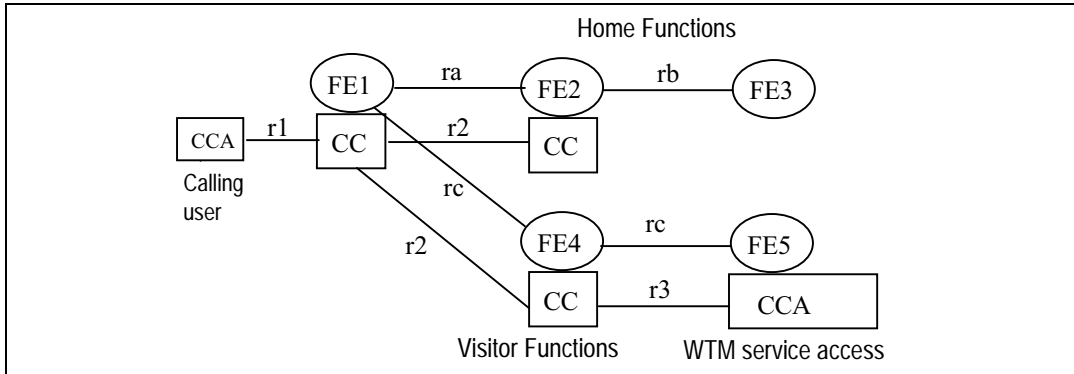

Figure 4 - Example relationship between model for ANF-WTMI and basic call

8.2 Information flows

8.2.1 Definition of information flows

In the tables listing the service elements in information flows, the column headed "Request" indicates which of these service elements are mandatory (M) and which are optional (O) in a request/indication information flow, and the column headed "Confirm" indicates which of these service elements are mandatory (M) and which are optional (O) in a response/confirmation information flow.

8.2.1.1 DIVERT

DIVERT is a confirmed information flow across ra from FE2 to FE1 which is used to cause FE1 to direct an incoming call to a WTMI user. The response indicates acceptance or failure.

Table 1 lists the service elements within the DIVERT information flow.

Table 1 - Contents of DIVERT

Service elements	Allowed value	Request	Confirm
Visitor PINX	PISN number	M	
Connection type		M (note 1)	
Calling user's PISN number (Originating number)		M (note 1)	
Calling user's subaddress (Originating subaddress)		O (note 1)	
WTMI user's PISN Number		O (note 2)	
WTMI user's alternative ID		O (note 2)	
WTMI user's subaddress (Destination subaddress)		O (note 1)	
Call History		O (note 1)	
Divert result	Accepted or Rejected		M
NOTE 1: This service element shall be obtained from the basic call SETUP request/indication information flow.			
NOTE2: At least one of these service elements shall be included.			

8.2.1.2 ENQUIRE

ENQUIRE is a confirmed information flow across rb from FE2 to FE3 which requests information regarding the current location of the WTMI user. The response indicates the WTMI user's current location or diversion destination or a failure reason.

Table 2 lists the service elements within the ENQUIRE information flow.

Table 2 - Contents of ENQUIRE

Service element	Allowed value	Request	Confirm
Destination number (note1)		M	
Connection type		M	
WTMI user's PISN number	Complete number		O (note 2)
WTMI user's alternative ID			O (note 2)
Enquiry result	- Visitor area known - CFU activated - WTMI user deregistered - Collision with Location Update - WTMI user unknown - WTMI user's location not known - Incompatible basic services		M
Visitor PINX	Complete PISN number		O (note 3)
WTMI user's diverted-to address			O (note 4)
WTMI user's diversion subscription options			O (note 4)
WTMI user's name			O (note 4)
NOTE 1: WTMI user's (partial or complete) PISN number.			
NOTE 2: If the Enquiry result contains visitor area known at least one of these service elements shall be included.			
NOTE 3: If the Enquiry result contains visitor area known this service element shall be included.			
NOTE 4: This optional service element shall be included if the Enquiry result is "Call Forward Unconditional activated" and if the information is available. SS-CFU overrides ANF-WTMI, as specified in 6.3.10.			

8.2.1.3 INFORM

INFORM is an unconfirmed information flow across rc from FE1 to FE4 and from FE4 to FE5 which conveys the WTMI user's identity.

Table 3 lists the service elements within the INFORM information flow.

Table 3 - Contents of INFORM

Service element	Allowed value	Request
WTMI user's PISN number		O (note)
WTMI user's alternative ID		O (note)
NOTE: At least one of these service elements shall be included.		

8.2.2 Relationship of information flows to basic call information flows

DIVERT request/indication shall be sent related to a basic call but independently of any basic call information flow.

DIVERT response/confirmation shall be sent

- in conjunction with the r2_RELEASE request/indication information flow,
- or related to a basic call but independently of any basic call information flow.

ENQUIRE request/indication and response/confirmation shall be sent independently of a basic call.

INFORM request/indication shall be sent in conjunction with the r2_SETUP and r3_SETUP request/indication information flow.

8.2.3 Examples of information flow sequences

A stage 3 Standard for ANF-WTMI shall provide signalling procedures in support of the information flow sequences specified below. In addition, signalling procedures should be provided to cover other sequences arising from error situations, interactions with basic call, interactions with other supplementary services, different topologies, etc.

In the figures, ANF-WTMI information flows are represented by solid arrows and basic call information flows are represented by broken arrows. An ellipse embracing two information flows indicates that the two information flows occur simultaneously. Within a column representing an ANF-WTMI functional entity, the numbers refer to functional entity actions listed in 8.3. The following abbreviations are used:

- req request
- ind indication
- resp response
- conf confirmation

8.2.3.1 Normal operation of ANF-WTMI

Figure 5 shows the information flow sequence for normal operation of ANF-WTMI.

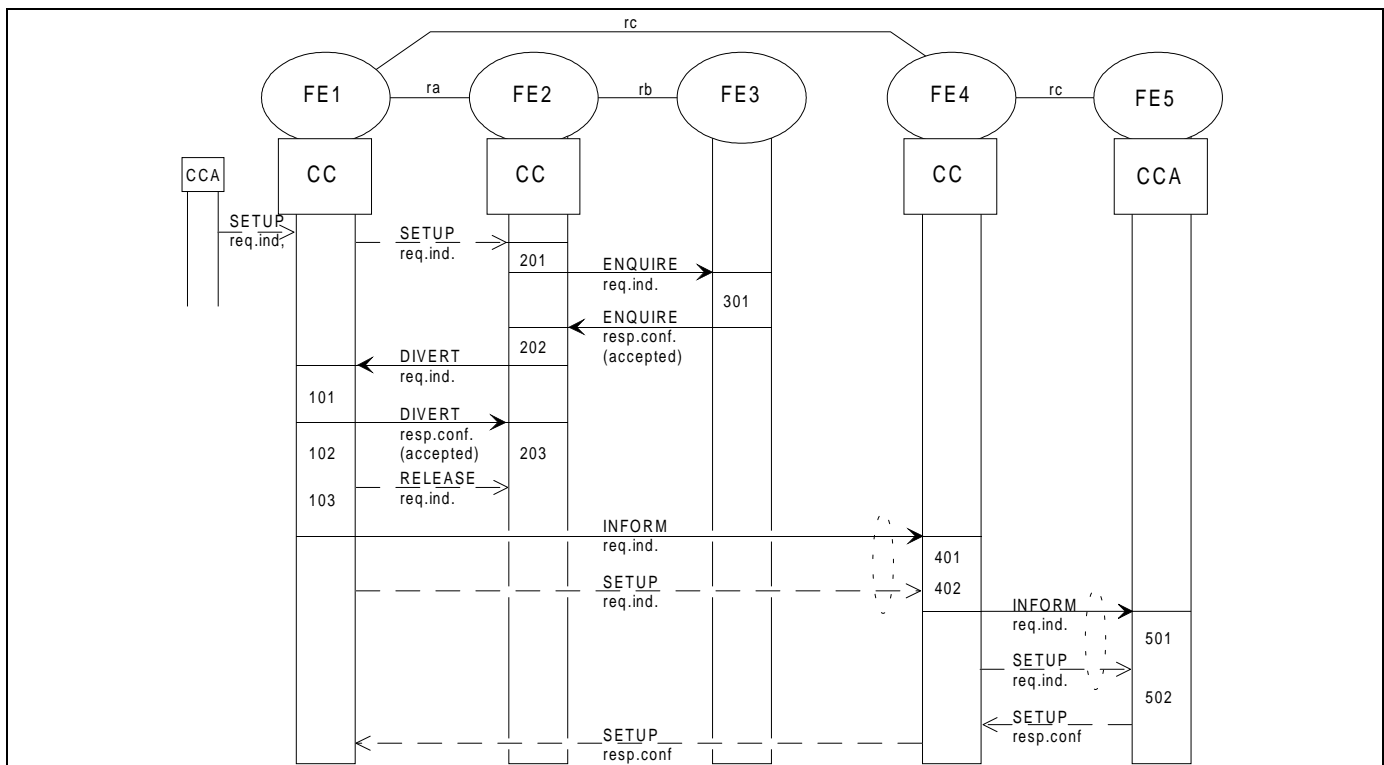

Figure 5 - Information flow sequence - normal operation of ANF-WTMI

8.2.3.2 Unsuccessful operation of ANF-WTMI

Information flow sequences for unsuccessful WTMI operation are shown in figure 6 to figure 9.

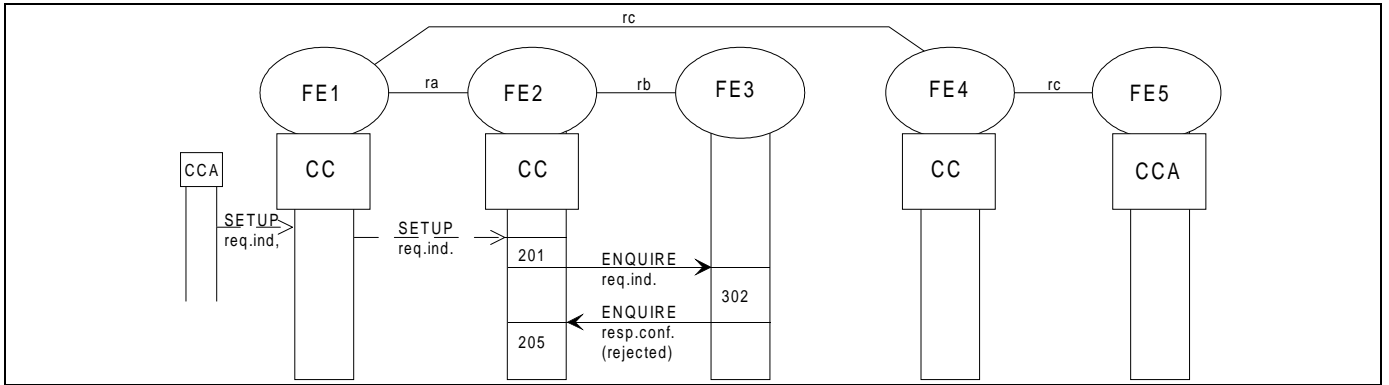

Figure 6 - Information flow sequence for unsuccessful WTMI operation: WTMI user (location) not known at home PINX or WTMI user deregistered

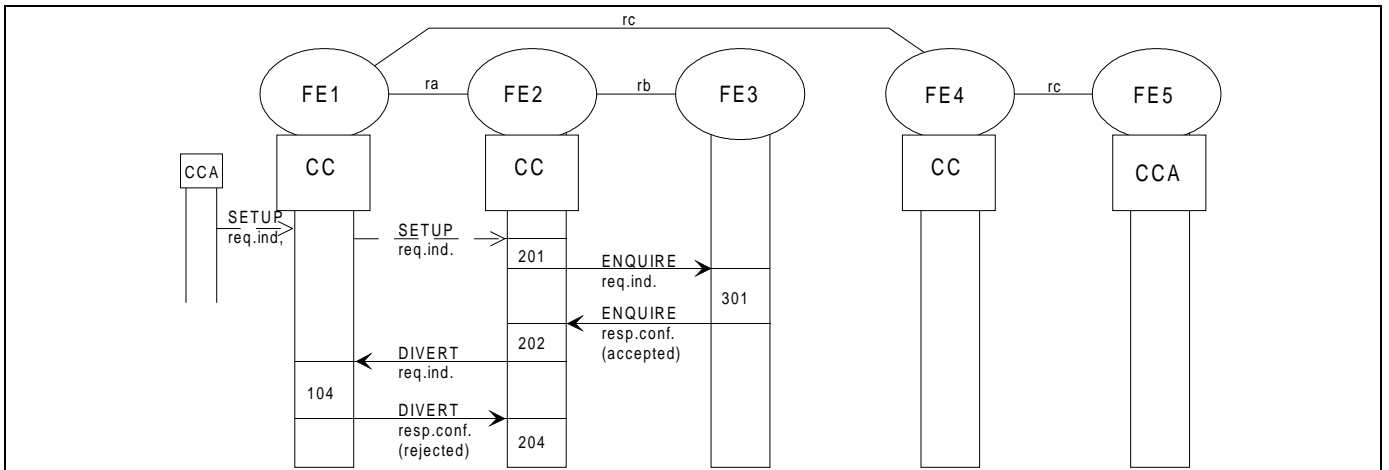

Figure 7 - Information flow sequence for unsuccessful WTMI operation: rejection of diversion

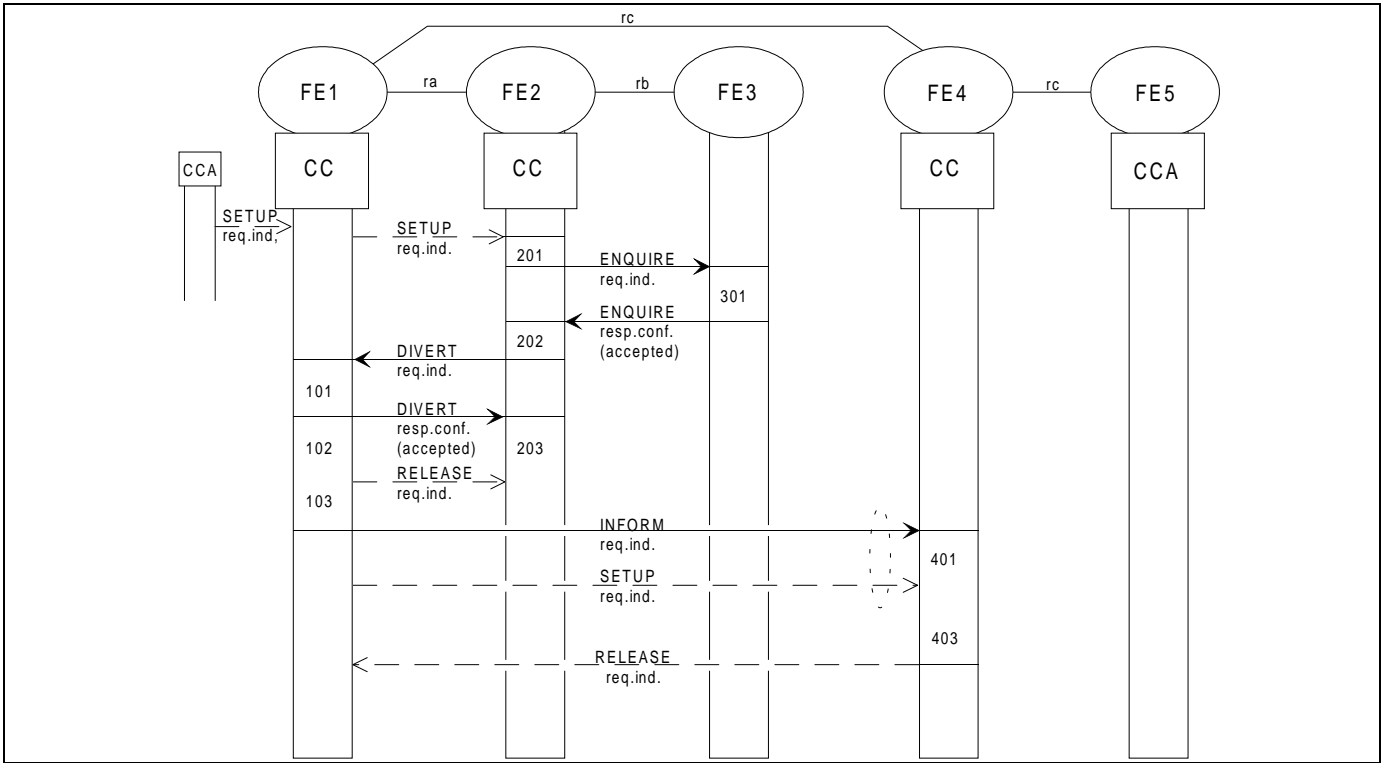

Figure 8 - Information flow sequence for unsuccessful WTMI operation: WTMI user not known at visitor PINX

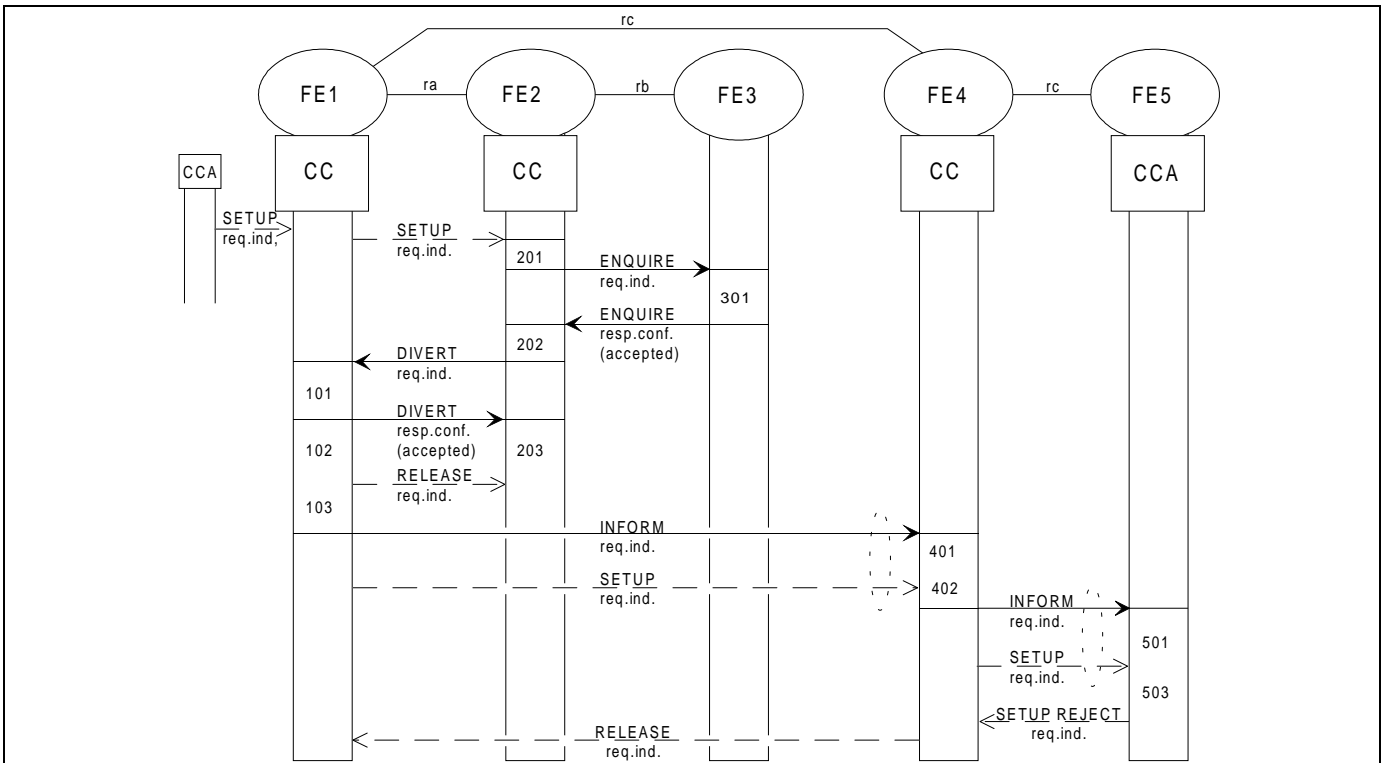

Figure 9 - Information flow sequence for unsuccessful WTMI operation: WTMI user not accessible

8.3 Functional entity actions

The following FE actions shall occur at the points indicated in the figures of 8.2.3.

8.3.1 Functional entity actions of FE1

- 101 Receive DIVERT req.ind from FE2. Formulate positive DIVERT resp.conf and send it to FE2.
- 102 Stimulate release of original basic call towards the WTMI user.
- 103 Stimulate new call setup using the PISN number of the Visitor PINX. Use WTMI user's identity already provided in the DIVERT req.ind to generate INFORM req.ind and send it to FE4 with the basic call SETUP req.ind.
- 104 Receive DIVERT req.ind from FE2. Formulate negative DIVERT resp.conf and send it to FE2.

8.3.2 Functional entity actions of FE2

- 201 Detect an incoming call to a WTMI user and send ENQUIRE req.ind to FE3.
- 202 Receive positive ENQUIRE resp.conf from FE3. Use contents of ENQUIRE to construct DIVERT and send DIVERT req.ind to FE1.
- 203 Receive positive DIVERT resp.conf from FE1.
- 204 Receive negative DIVERT resp.conf from FE1 and stimulate the release of the original basic call or try another FE1.
- 205 Receive negative ENQUIRE resp.conf from FE3 and stimulate the release of the original basic call.

8.3.3 Functional entity actions of FE3

- 301 Receive ENQUIRE req.ind from FE2. Get the PISN number of the Visitor PINX from the HDB. Formulate positive ENQUIRE resp.conf and send to FE2.
- 302 Receive ENQUIRE req.ind from FE2. Formulate negative ENQUIRE resp.conf, insert the reason, and send it to FE2.

8.3.4 Functional entity actions of FE4

- 401 Receive INFORM req.ind with the basic call SETUP req.ind from FE1.
- 402 If the WTMI user is registered in the VDB, stimulate basic call establishment to the WTM service access and send INFORM req.ind with the SETUP req.ind.
- 403 If the WTMI user is not registered in the VDB, stimulate the release of basic call.

8.3.5 Functional entity actions of FE5

- 501 Receive INFORM req.ind from FE4 with the basic call SETUP req.ind.
- 502 If the WTMI user is accessible, stimulate basic call establishment to the WTMI user's terminal.
- 503 If the WTMI user is not accessible (e.g. out of range), stimulate the release of basic call.

8.4 Functional entity behaviour

The FE behaviours shown below are intended to illustrate typical FE behaviour in terms of information flows sent and received.

The behaviour of each FE is shown using the Specification and Description Language (SDL) defined in ITU-T Rec. Z.100. Each input and output symbol is labelled to show the source FE of input signals or the destination FE of output signals.

8.4.1 Behaviour of FE1

Figure 10 shows the normal behaviour of FE1.

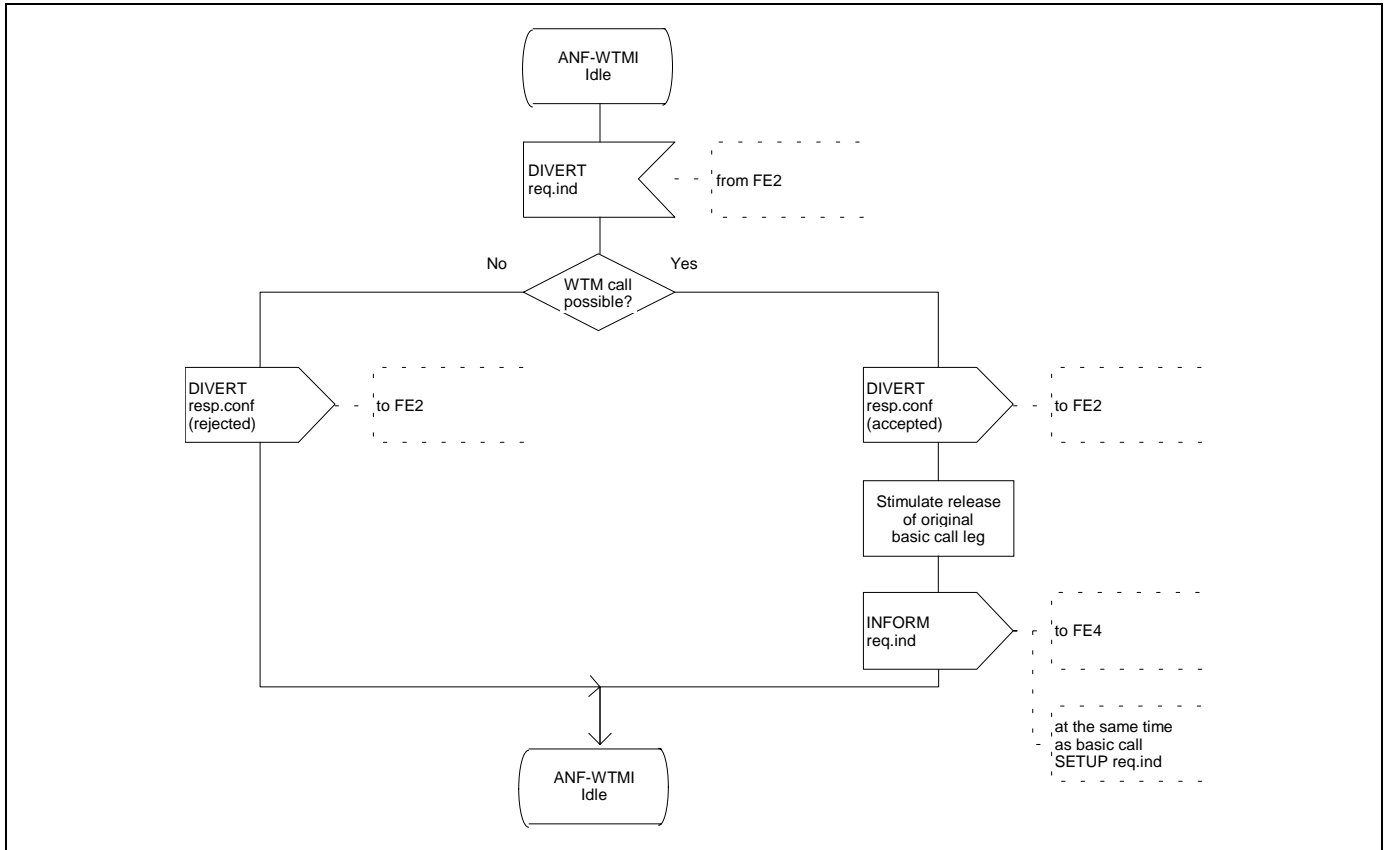

Figure 10 - ANF-WTMI, SDL for functional entity FE1

8.4.2 Behaviour of FE2

Figure 11 shows the normal behaviour of FE2.

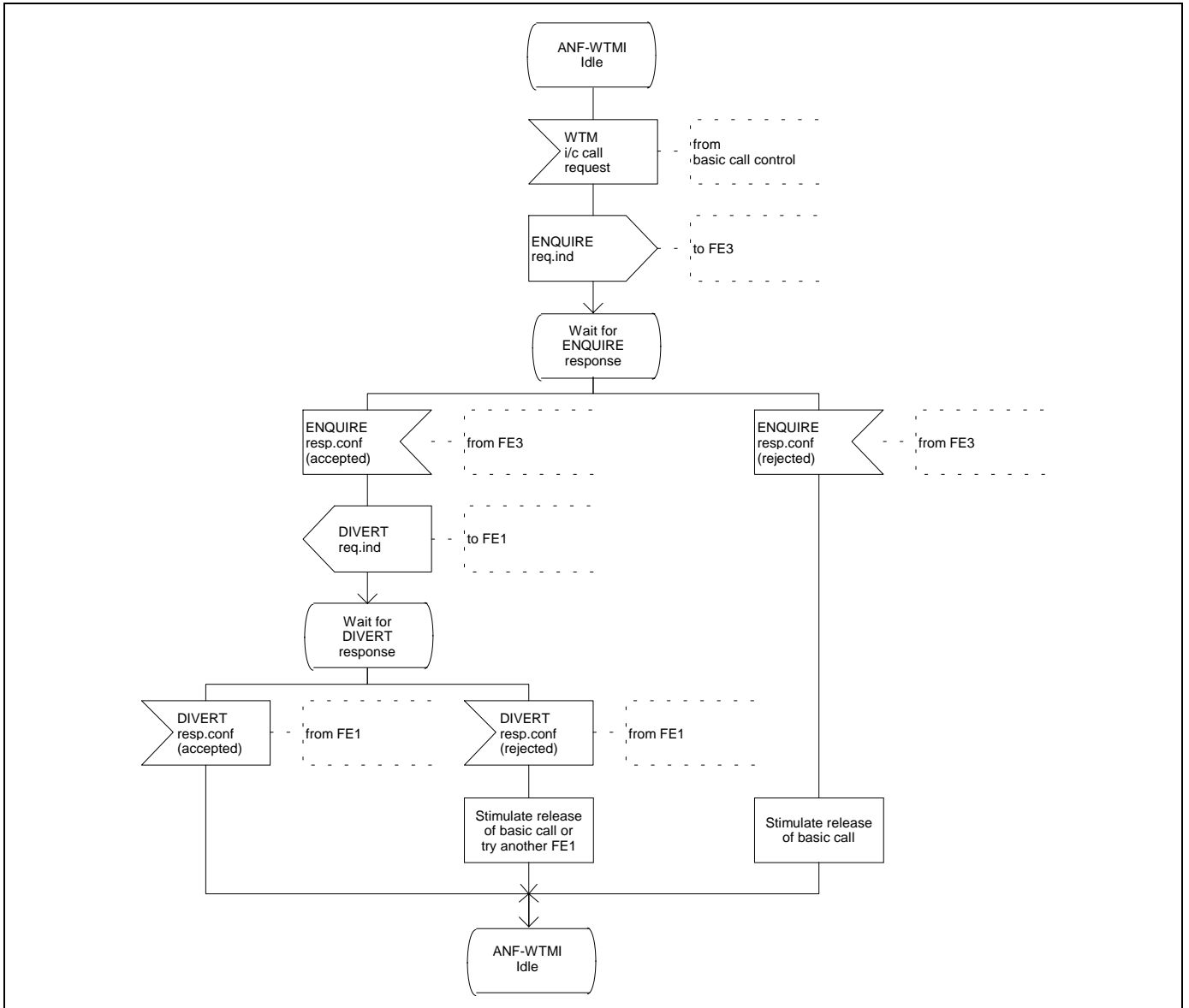

Figure 11 - ANF-WTMI, SDL for functional entity FE2

8.4.3 Behaviour of FE3

Figure 12 and figure 13 show the normal behaviour of FE3.

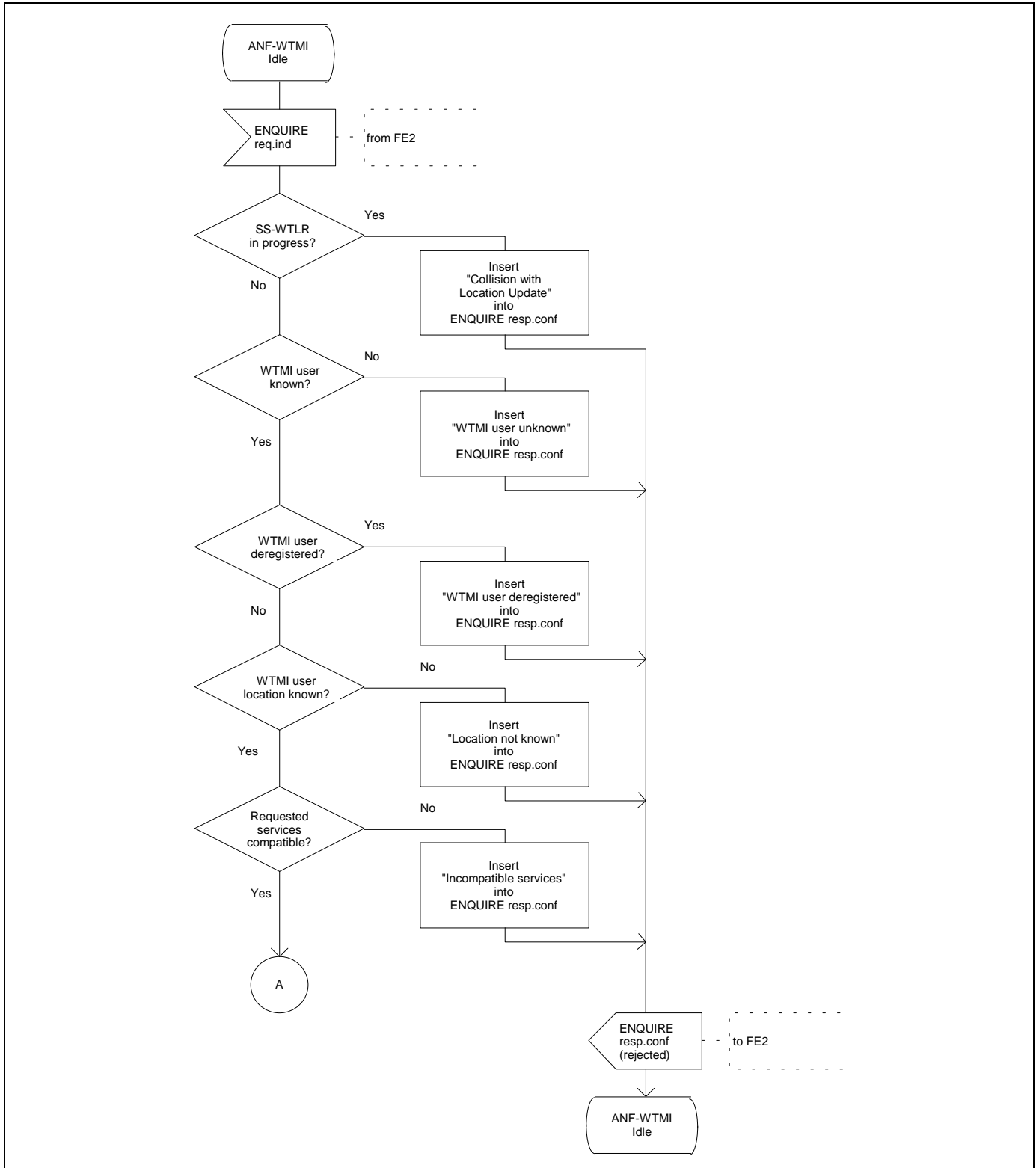

Figure 12 - ANF-WTMI, SDL for functional entity FE3 (page 1 of 2)

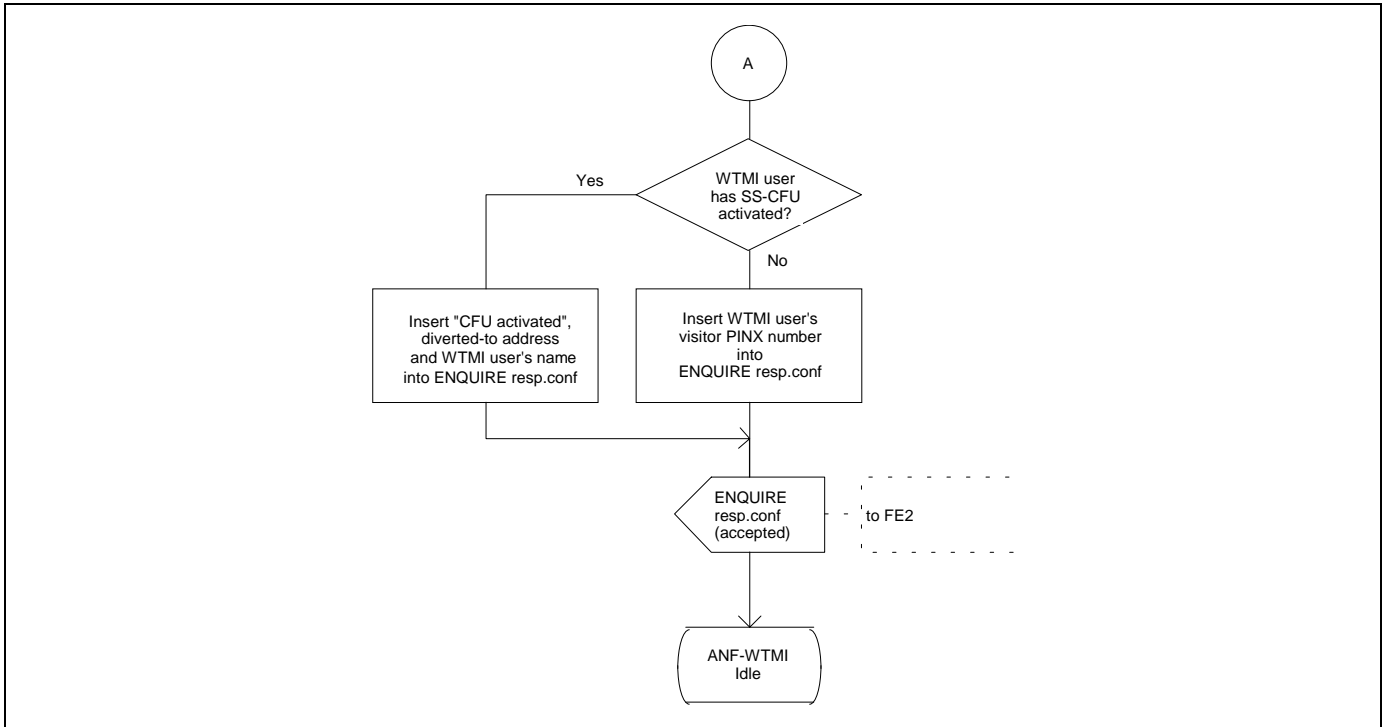

Figure 13 - ANF-WTMI, SDL for functional entity FE3 (page 2 of 2)

8.4.4 Behaviour of FE4

Figure 14 shows the normal behaviour of FE4.

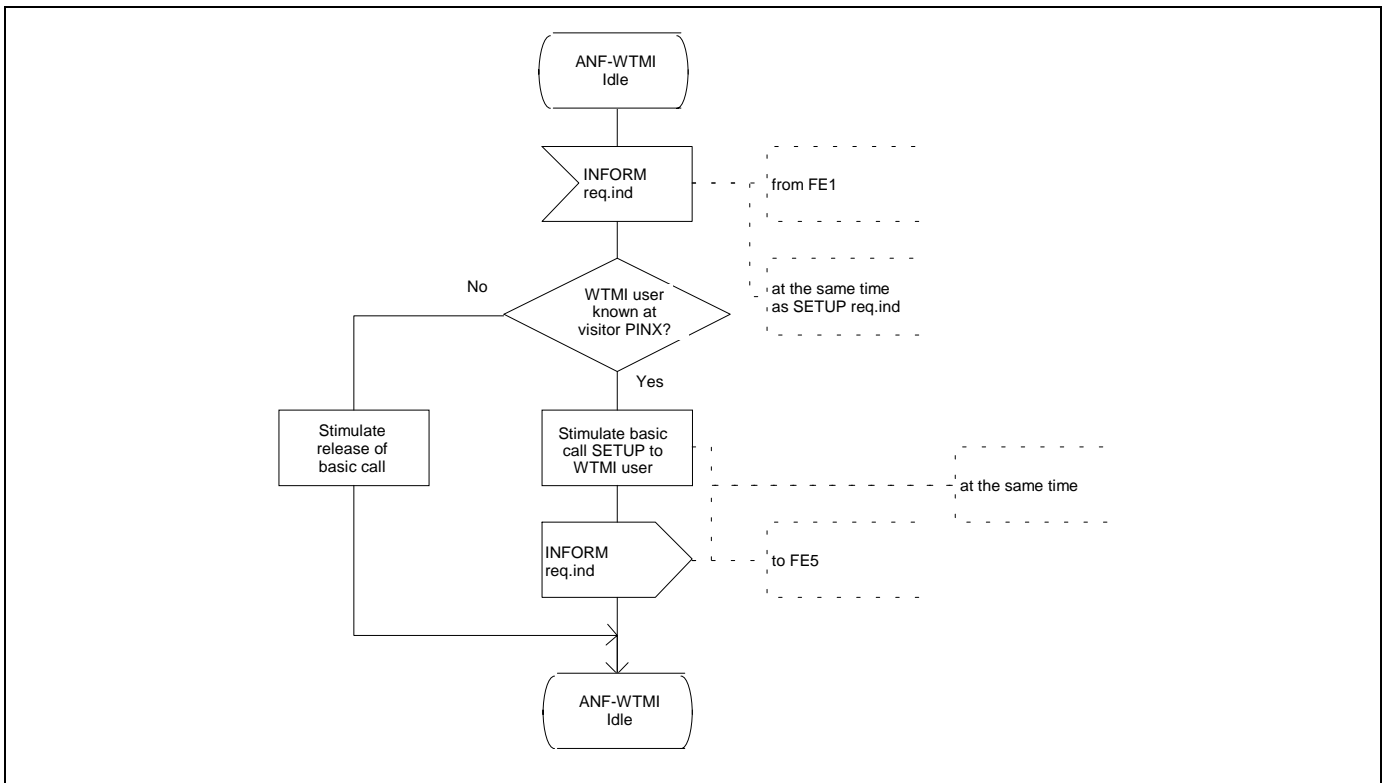

Figure 14 - ANF-WTMI, SDL for functional entity FE4

8.4.5 Behaviour of FE5

Figure 15 shows the normal behaviour of FE5.

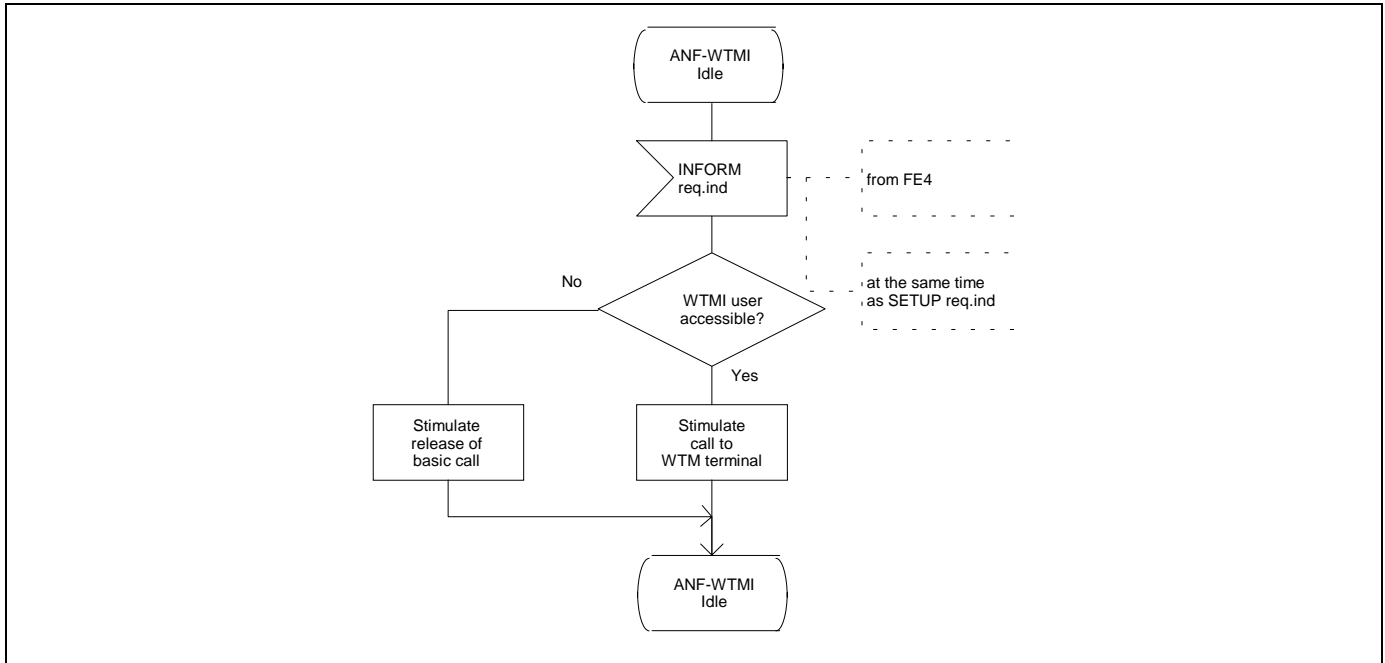

Figure 15 - ANF-WTMI, SDL for functional entity FE5

8.5 Allocation of functional entities to physical equipment

The allocation of FEs to physical locations is shown in table 4.

Within the context of table 4:

- the originating PINX is the PINX to which the calling user is attached;
- the terminating PINX is the PINX to which the FP is connected;
- a transit PINX is any other PINX through which the call passes.

For the purposes of this Standard, the visitor PINX shall be the terminating PINX.

Table 4 - Allocation of FEs to physical locations

	FE1	FE2	FE3	FE4	FE5
Scenario 1	Originating PINX	Home PINX	Home PINX	Visitor PINX	Terminating PINX
Scenario 2	Originating PINX	Home PINX	Home PINX	Visitor PINX	FP
Scenario 3	Originating PINX	Transit PINX	Home PINX	Visitor PINX	Terminating PINX
Scenario 4	Originating PINX	Transit PINX	Home PINX	Visitor PINX	FP
Scenario 5	Originating PINX	Originating PINX	Home PINX	Visitor PINX	Terminating PINX
Scenario 6	Originating PINX	Originating PINX	Home PINX	Visitor PINX	FP
Scenario 7	Home PINX	Home PINX	Home PINX	Visitor PINX	Terminating PINX
Scenario 8	Home PINX	Home PINX	Home PINX	Visitor PINX	FP
Scenario 9 (note)	Transit PINX	Transit PINX	Home PINX	Visitor PINX	Terminating PINX
Scenario 10 (note)	Transit PINX	Transit PINX	Home PINX	Visitor PINX	FP
NOTE: In scenarios where FE1 and FE2 are both allocated to a transit PINX, this shall be the same transit PINX.					

8.6 Interworking considerations

If the calling user is in another network, "Originating PINX" is replaced by "Incoming Gateway PINX" in table 4.

The incoming gateway PINX is the PINX which links the calling user's network to the PISN.

9 ANF-WTMO stage 2 specification

9.1 Functional model

9.1.1 Functional model description

The functional model shall comprise the following functional entities:

FE1: Outgoing WTM call detection and control;

FE2: Visited location information provision;

FE3: Home location WTM call control.

The following functional relationships shall exist between these FEs:

ra: between FE1 and FE2;

rb: between FE1 and FE3.

Figure 16 shows these FEs and relationships.

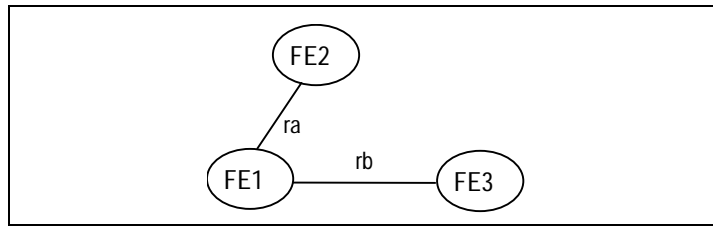

Figure 16 - Functional model for ANF-WTMO

9.1.2 Description of functional entities

9.1.2.1 Outgoing WTM call detection and control, FE1

This functional entity controls the actions of ANF-WTMO and interacts with outgoing call control. If required, it will use the originating number (i.e. the WTMO user's PISN number) to redirect the call to the home location for processing.

9.1.2.2 Visited location information provision, FE2

This functional entity retrieves data from the VDB and verifies the originating number when requested by FE1.

9.1.2.3 Home location WTM call control, FE3

This functional entity receives a WTM call for further processing when it is redirected by FE1 to the home PINX of the WTMO user.

9.1.3 Relationship of functional model to basic call functional model

FE1 shall be co-located with the originating CC.

FE3, if present, shall be co-located with the CC representing the WTMO user's home PINX.

Figure 17 shows an example of the relationship between the functional model and a basic call.

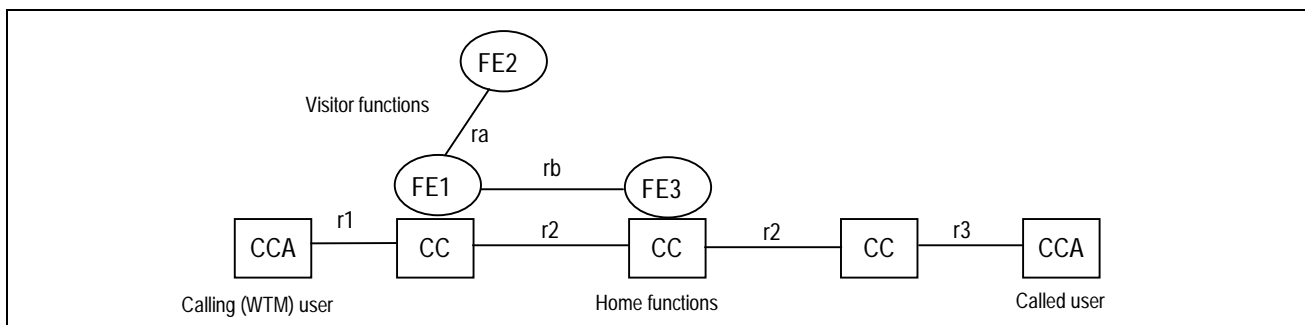

Figure 17 - Example relationship between model for ANF-WTMO and basic call

9.2 Information flows

9.2.1 Definition of information flows

In the tables listing the service elements in information flows, the column headed "Request" indicates which of these service elements are mandatory (M) and which are optional (O) in a request/indication information flow, and the column headed "Confirm" indicates which of these service elements are mandatory (M) and which are optional (O) in a response/confirmation information flow.

9.2.1.1 INFORM1

INFORM1 is an unconfirmed information flow across rb from FE1 to FE3 which shall be sent if the call is redirected to the home location for remote processing.

Table 5 shows the information content of the INFORM1 information flow.

Table 5 - Contents of INFORM1

Service element	Allowed value	Request
Original destination number		O (note 1)
Sending complete indicator		O (note 2)
<p>NOTE 1: In the case that en-bloc basic call procedures apply, this element shall contain the whole destination number. In the case of overlap sending, this element may contain the digits of the destination number so far available. The remaining part of the destination number will be sent by repeating the INFORM1 flow.</p> <p>NOTE 2: May be included to indicate that the destination number is complete.</p>		

9.2.1.2 VERIFY

VERIFY is a confirmed information flow across ra from FE1 to FE2 which requests looking up of the VDB record associated with the calling user. The response indicates the result of the look-up.

Table 6 shows the information content of the VERIFY information flow.

Table 6 - Contents of VERIFY

Service element	Allowed value	Request	Confirm
Originating number		M	O (note 1)
Service profile			O (note 2)
Result	- number verified - user not known		M
<p>NOTE 1: Shall be included if the number is different from that in the request.</p> <p>NOTE 2: May be included in the case of successful verification.</p>			

9.2.2 Relationship of information flows to basic call information flows

INFORM1 request/indication shall be sent

- in conjunction with the r2_SETUP request/indication information flow,
- or related to a basic call but independently of any basic call information flow.

VERIFY request/indication and response/confirmation shall be sent independently of a basic call.

9.2.3 Examples of information flow sequences

A stage 3 Standard for ANF-WTMO shall provide signalling procedures in support of the information flow sequences specified below. In addition, signalling procedures should be provided to cover other sequences arising from error situations, interactions with basic call, interactions with other supplementary services, different topologies, etc.

In the figures, ANF-WTMO information flows are represented by solid arrows and basic call information flows are represented by broken arrows. An ellipse embracing two information flows indicates that the two information flows occur simultaneously. Within a column representing an ANF-WTMO functional entity, the numbers refer to functional entity actions listed in 9.3. The following abbreviations are used:

req	request
ind	indication
resp	response
conf	confirmation

9.2.3.1 Normal operation of ANF-WTMO

Figure 18 and figure 19 show information flow sequences for normal operation of ANF-WTMO.

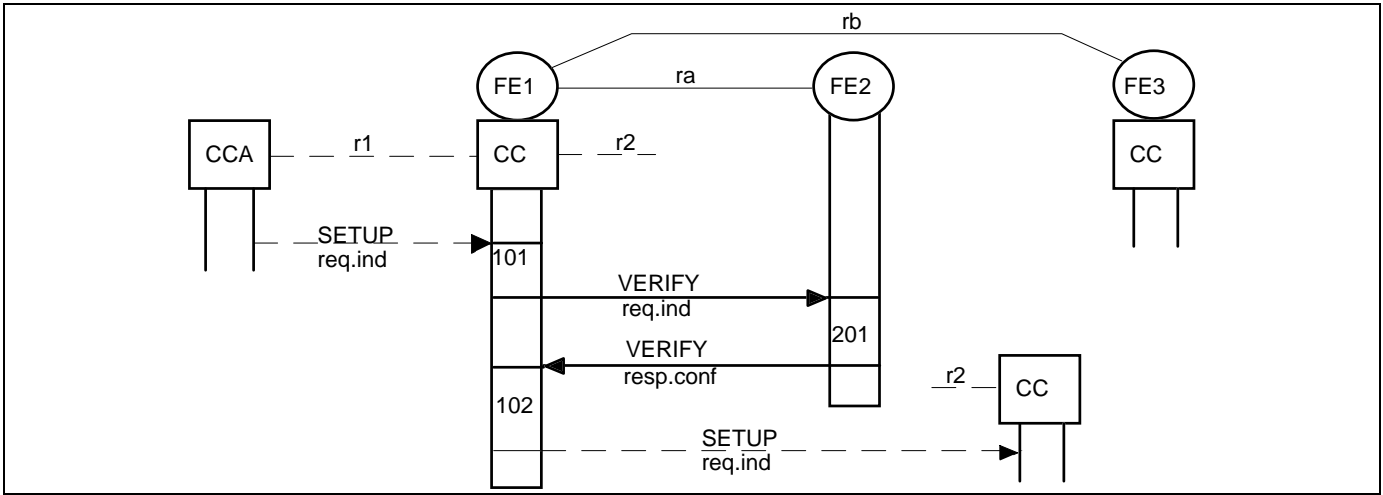

Figure 18 - Information flow sequence for successful WTMO operation: no redirection

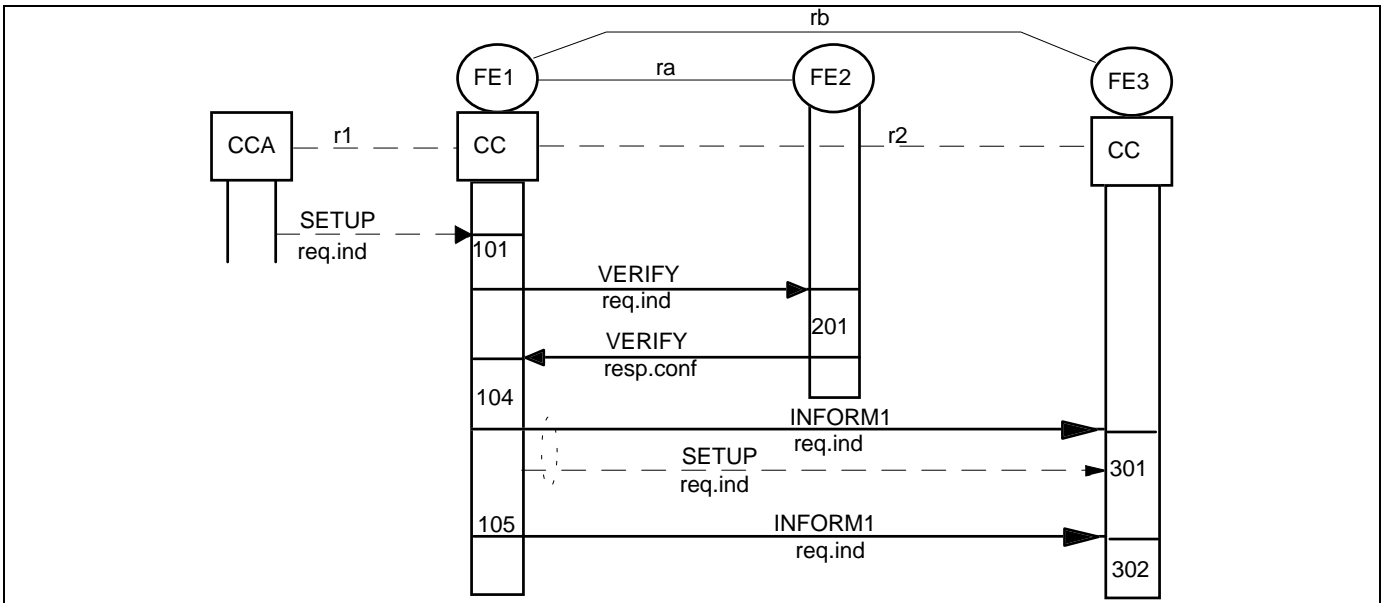

Figure 19 - Information flow sequence for successful WTMO operation: redirection to home location

9.2.3.2 Unsuccessful operation of ANF-WTMO

An information flow sequence for an unsuccessful WTMO operation is shown in figure 20.

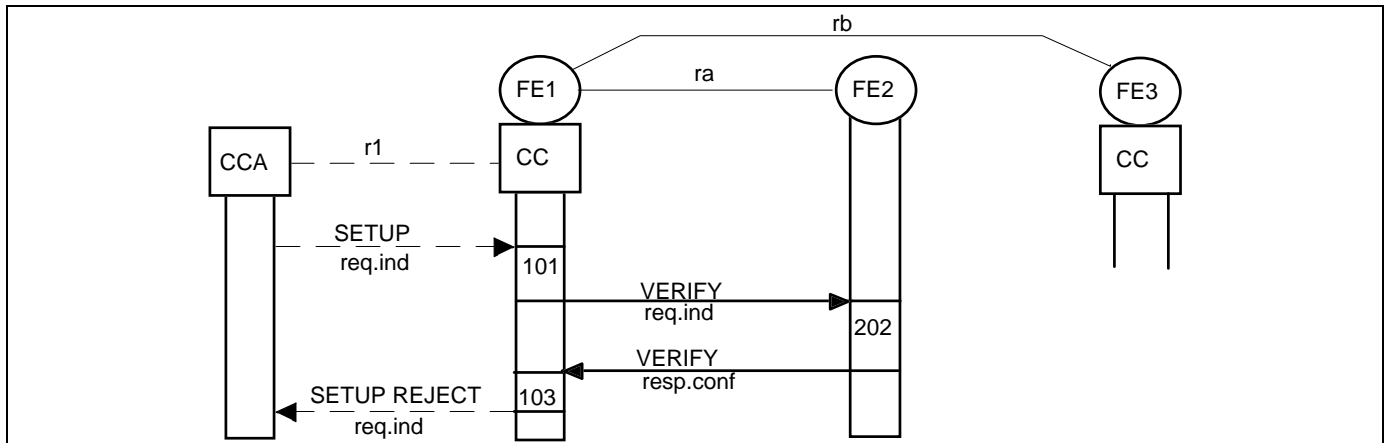

Figure 20 - Information flow sequence for unsuccessful WTMO operation: no matching VDB record found

9.3 Functional entity actions

The following FE actions shall occur at the points indicated in the figures of 9.2.3.

9.3.1 Functional entity actions of FE1

- 101 Send a VERIFY request with the calling user's number to FE2 and wait for the response.
- 102 Receive a positive VERIFY resp.conf from FE2. Choose local processing, make service profile available to call control; continue with basic call setup.
- 103 Receive a negative VERIFY resp.conf from FE2. Reject the basic call request.
- 104 Receive a positive VERIFY resp.conf from FE2. Choose remote processing, redirect the call to the home location (FE3), using the address of the home PINX as destination number, and include an INFORM1 flow, with (part of) the original destination number if available. Optionally include the sending complete indicator if the whole original destination number is sent.
- 105 Send INFORM1 req.ind with further digit(s) of the original destination number and/or a sending complete indicator (optionally, if the last digit was sent). This action is repeated until the whole number has been sent.

9.3.2 Functional entity actions of FE2

- 201 Receive a VERIFY req.ind from FE1. Get the VDB record associated with the calling user and verify the originating number. Return a positive VERIFY resp.conf to FE1.
- 202 Receive a VERIFY req.ind from FE1. If no matching VDB record is found return a VERIFY confirmation with a failure indication to FE1.

9.3.3 Functional entity actions of FE3

- 301 Receive an INFORM1 req.ind from FE1. If the whole original destination number is contained in INFORM1, reinsert the number and process the call, using normal outgoing call control procedures. Otherwise wait for further digits of the original destination number.
- 302 When the original destination number is complete, reinsert the number and process the call, using normal outgoing call control procedures. Otherwise wait for further digits. This action is repeated until the whole original destination number has been received.

9.4 Functional entity behaviour

The FE behaviours shown below are intended to illustrate typical FE behaviour in terms of information flows sent and received.

The behaviour of each FE is shown using the Specification and Description Language (SDL) defined in ITU-T Rec. Z.100. Each input and output symbol is labelled to show the source FE of input signals or the destination FE of output signals.

9.4.1 Behaviour of FE1

Figure 21 shows the normal behaviour of FE1.

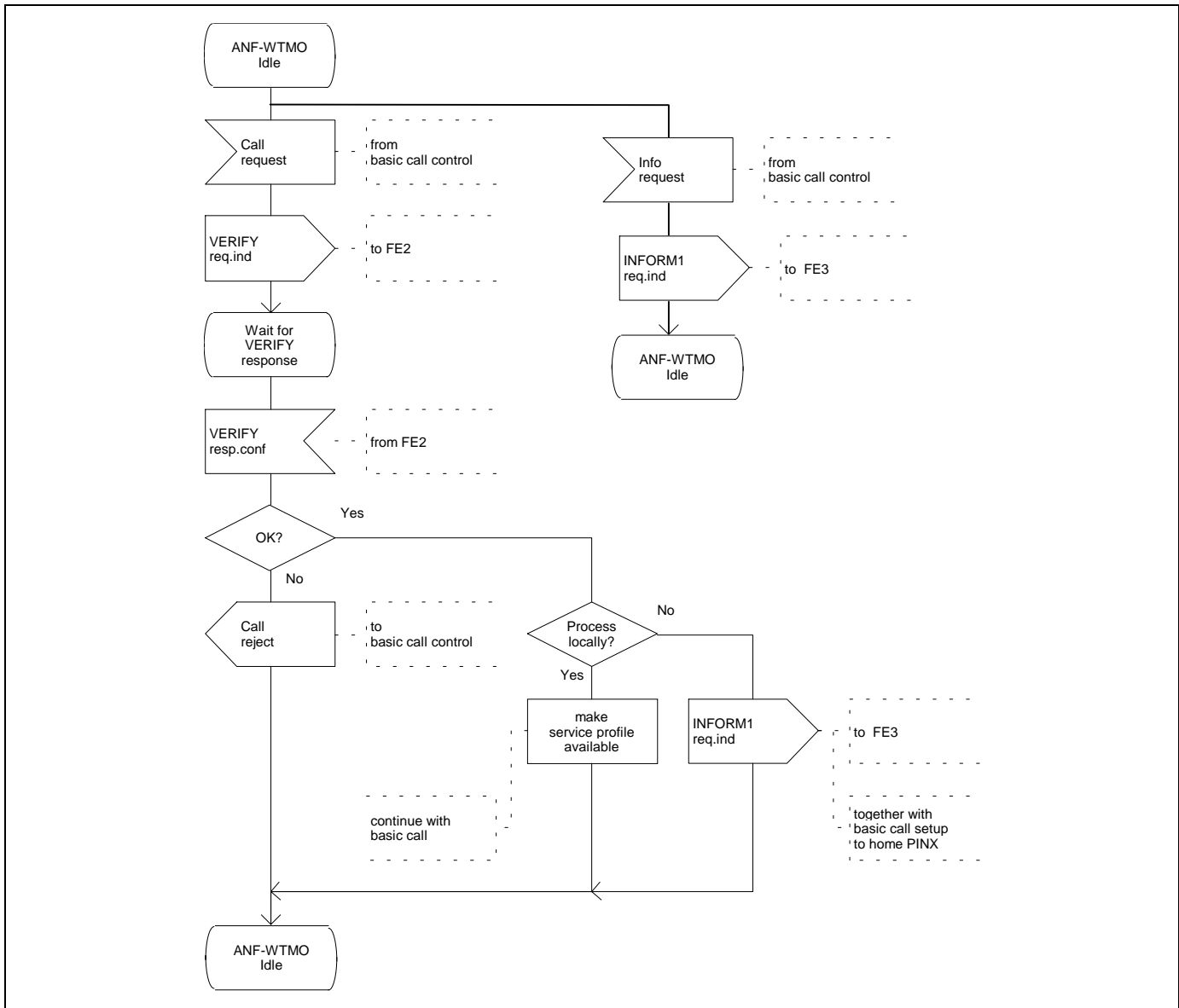

Figure 21 - ANF-WTMO, SDL for functional entity FE1

9.4.2 Behaviour of FE2

Figure 22 shows the normal behaviour of FE2.

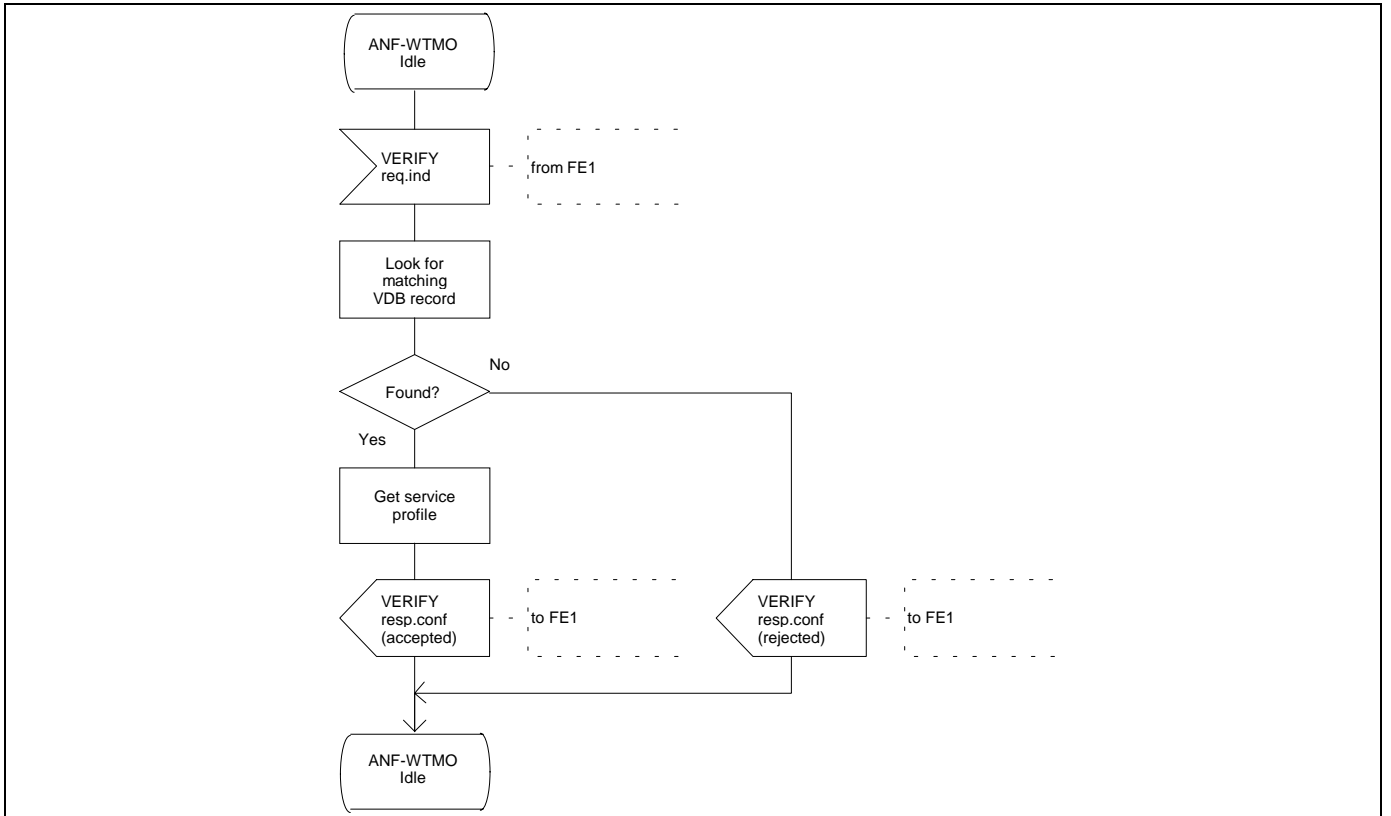

Figure 22 - ANF-WTMO, SDL for functional entity FE2

9.4.3 Behaviour of FE3

Figure 23 shows the normal behaviour of FE3.

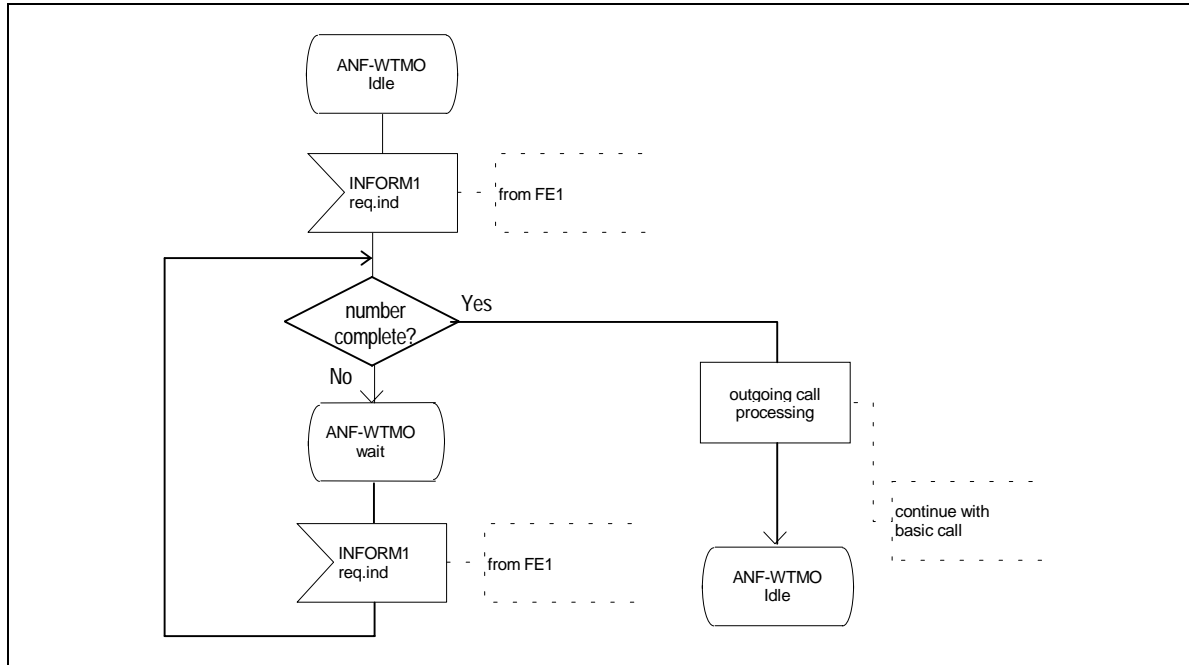

Figure 23 - ANF-WTMO, SDL for functional entity FE3

9.5 Allocation of functional entities to physical equipment

The allocation of FEs to physical locations is shown in table 7.

Within the context of table 7, the originating PINX is the PINX to which the FP is attached.

For the purposes of this Standard, the visitor PINX shall be the originating PINX.

Table 7 - Allocation of FEs to physical locations

	FE1	FE2	FE3
Scenario 1	Originating PINX	Visitor PINX	Home PINX

9.6 Interworking considerations

Not applicable.

Free printed copies can be ordered from:

ECMA

114 Rue du Rhône

CH-1204 Geneva

Switzerland

Fax: +41 22 849.60.01

Email: documents@ecma.ch

Files of this Standard can be freely downloaded from the ECMA web site (www.ecma.ch). This site gives full information on ECMA, ECMA activities, ECMA Standards and Technical Reports.

ECMA
114 Rue du Rhône
CH-1204 Geneva
Switzerland

See inside cover page for obtaining further soft or hard copies.