

Standard ECMA-349

1st Edition - December 2003

**Data Interchange on
120 mm and 80 mm
Optical Disk using
+R Format - Capacity:
4,7 and 1,46 Gbytes
per Side
(Recording speed up to 4X)**

Standard

Standard
ECMA-349

1st Edition - December 2003

**Data Interchange on
120 mm and 80 mm
Optical Disk using
+R Format - Capacity:
4,7 and 1,46 Gbytes
per Side
(Recording speed up to 4X)**

Brief history

Ecma Technical Committee TC31 was established in 1984 for the standardization of Optical Disks and Optical Disk Cartridges (ODC). Since its establishment, the Committee has made major contributions to ISO/IEC toward the development of International Standards for 80 mm, 90 mm, 120 mm, 300 mm, and 356 mm media. Numerous standards have been developed by TC31 and published by Ecma, almost all of which have also been adopted by ISO/IEC under the fast-track procedure as International Standards.

In April 2003 a group of Companies proposed to TC31 to develop a standard for 120 mm recordable optical disks using the WORM recording technology and based on the DVD – Read-Only standard (ECMA-267) and the +RW format (ECMA-337). TC31 adopted this project and started the work that has resulted in this Ecma Standard.

This Ecma Standard specifies two Types of recordable optical disks, one (Type S) making use of recording on only a single side of the disk and yielding a nominal capacity of 4,7 or 1,46 Gbytes per disk and the other (Type D) making use of recording on both sides of the disk and yielding a nominal capacity of 9,4 or 2,92 Gbytes per disk.

This Ecma Standard, taken together with a standard for volume and file structure, such as for instance developed in Ecma Technical Committee TC15, provides the requirements for information interchange between systems.

The December 2003 General Assembly adopted this, 1st edition, of ECMA-349.

Table of contents

Section 1 - General		1
1	Scope	1
2	Conformance	1
2.1	Optical Disk	1
2.2	Generating system	1
2.3	Receiving system	1
2.4	Compatibility statement	1
3	References	2
4	Definitions	2
4.1	Channel bit	2
4.2	Clamping Zone	2
4.3	Digital Sum Value (DSV)	2
4.4	Disk Reference Plane	2
4.5	dummy substrate	2
4.6	entrance surface	2
4.7	field	2
4.8	groove	2
4.9	interleaving	2
4.10	mark	2
4.11	Multi-session disk	2
4.12	Physical Sector	3
4.13	recording layer	3
4.14	Reed-Solomon code (RS)	3
4.15	Single-session disk	3
4.16	session	3
4.17	space	3
4.18	substrate	3
4.19	track	3
4.20	track pitch	3
4.21	wobble	3
4.22	zone	3

5	Conventions and notations	3
5.1	Representation of numbers	3
5.2	Names	4
6	List of acronyms	4
7	General description of the optical disk	5
8	General Requirements	6
8.1	Environments	6
8.1.1	Test environment	6
8.1.2	Operating environment	6
8.1.3	Storage environment	6
8.1.4	Transportation	6
8.2	Safety requirements	6
8.3	Flammability	6
9	Reference Drive	7
9.1	Optical system	7
9.2	Optical beam	7
9.3	Read channel 1	8
9.4	Disk clamping	8
9.5	Rotation of the disk	9
9.6	Wobble channel (Read channel 2)	9
9.7	Tracking channel (Read channel 2)	9
9.7.1	Normalized servo transfer function	9
9.7.2	Reference Servo for Axial Tracking	10
9.7.3	Reference Servo for Radial Tracking	11
Section 2 - Dimensional, mechanical and physical characteristics of the disk		12
10	Dimensional characteristics	12
10.1	Reference Planes	12
10.2	Overall dimensions	12
10.3	First transition area	13
10.4	Second transition area	13
10.5	Clamping Zone	13
10.6	Third transition area	13
10.7	Information Zone	13
10.8	Rim Area	14
10.9	Remark on tolerances	14

11	Mechanical characteristics	16
11.1	Mass	16
11.2	Moment of inertia	16
11.3	Dynamic imbalance	16
11.4	Axial runout	16
11.5	Radial runout	16
12	Optical characteristics in the Information Zone	17
12.1	Index of refraction	17
12.2	Thickness of the substrate	17
12.3	Reflectivity	17
12.4	Birefringence	17
12.5	Angular deviation	18
Section 3 - Format of information		19
13	Data format	19
13.1	Data Frames	19
13.1.1	Identification Data (ID)	20
13.1.2	ID Error Detection Code (IED)	20
13.1.3	RSV	20
13.1.4	Error Detection Code (EDC)	21
13.2	Scrambled Frames	21
13.3	ECC Blocks	22
13.4	Recording Frames	23
13.5	Modulation and NRZI conversion	24
13.6	Physical Sectors	24
13.7	Layout of a Recording UNit (RUN)	26
13.7.1	Recording Unit position	26
13.8	d.c. component suppression control	27
14	Track format	28
14.1	Track shape	28
14.2	Track path	28
14.3	Track pitch	28
14.4	Track layout	28
14.4.1	ADIP information	28
14.4.2	Physical format information in ADIP	33
Section 4 - Format of the Information Zone		45
15	General description of the Information Zone	45

16	Layout of the Information Zone of a Single-session disk	45
16.1	Physical Sector Numbers (PSNs)	45
17	Inner Drive Area	46
17.1	Initial Zone	47
17.2	Inner Disk Test Zone	47
17.3	Count Zone Run-in	47
17.4	Inner Disk Count Zone	47
17.5	Inner Disk Administration Zone	47
17.6	Table of Contents (TOC) Zone	48
17.6.1	Table of Contents Blocks	48
17.6.2	Recorded Area Indicators	51
18	Lead-in Zone	51
18.1	Guard Zone 1	51
18.2	Reserved Zone 1	51
18.3	Reserved Zone 2	52
18.4	Inner Disk Identification Zone	52
18.5	Reserved Zone 3	52
18.6	Reference Code Zone	52
18.7	Buffer Zone 1	53
18.8	Control Data Zone	53
18.8.1	Physical format information	53
18.8.2	Disk manufacturing information	55
18.8.3	Content provider information	55
18.9	Buffer Zone 2	55
19	Data Zone	55
20	Lead-out Zone	55
20.1	Buffer Zone 3	56
20.2	Outer Disk Identification Zone	56
20.3	Guard Zone 2	56
21	Outer Drive Area	56
21.1	Outer Disk Administration Zone	57
21.2	Outer Disk Count Zone	57
21.3	Outer Disk Test Zone	57
21.4	Guard Zone 3	57

22	Multi-session Layout	58
22.1	Intro	59
22.1.1	Buffer Zone A	59
22.1.2	Inner Session Identification Zone	59
22.1.3	Session Control Data Zone	59
22.1.4	Buffer Zone B	59
22.2	Data Zone	59
22.3	Closure	59
22.3.1	Buffer Zone C	59
22.3.2	Outer Session Identification Zone	59
23	Sequential recording in Fragments	60
23.1	Opening a Session	60
23.1.1	Incomplete Fragment	60
23.1.2	Reserved Fragments	60
23.1.3	Recording User Data in Fragments	61
23.1.4	Closing a Fragment	61
23.2	Closing a Session	62
23.2.1	Lead-in/Intro Zone	62
23.2.2	Closure Zone	62
23.3	Finalizing the disk	62
24	Assignment of Logical Sector Numbers (LSNs)	63
25	Disk Control Blocks	63
25.1	General format of Disk Control Blocks	63
25.2	Format of the Session DCB (SDCB)	64
25.2.1	Session Items	66
Section 5 – Characteristics of the groove		69
26	General	69
27	Method of testing	69
27.1	Environment	69
27.2	Reference Drive	69
27.2.1	Optics and mechanics	69
27.2.2	Read power	69
27.2.3	Read channels	69
27.2.4	Tracking	69
27.3	Definition of signals	70
28	Characteristics of the groove signals	71
28.1	Phase depth	71

28.2	Push-pull signal	71
28.3	Track Cross signal	71
28.4	Normalized wobble signal	71
28.5	Characteristics of the wobble	71
Section 6 - Characteristics of the recording layer		72
29	Method of testing	72
29.1	Environment	72
29.2	Reference Drive	72
29.2.1	Optics and mechanics	72
29.2.2	Read power	72
29.2.3	Read channels	72
29.2.4	Tracking	72
29.2.5	Scanning velocity	72
29.3	Write conditions	73
29.3.1	Write pulse waveform	73
29.3.2	Write power	73
29.3.3	Write power dependency on wavelength	73
29.3.3	Write power window	73
29.4	Measurement conditions	74
30	Characteristics of the recorded signals	75
30.1	Channel bit length	75
30.2	Definition of signals	75
30.2.1	High frequency signals (HF)	75
30.2.2	Modulated amplitude	75
30.2.3	Signal asymmetry	76
30.2.4	Normalized Slicing Level jump	76
30.2.5	Jitter	76
30.2.6	Track Cross signal	76
30.3	Read stability	76
31	Additional testing conditions	77
31.1	Test environment	77
31.1.1	Optics	77
31.2	Definition of signals	77
31.2.1	Modulated amplitude	77
31.2.2	Signal asymmetry	77
31.2.3	Jitter	77
31.2.4	Track Cross signal	78
31.2.5	Differential phase tracking error signal	78
31.2.6	Tangential push-pull signal	79

32	Quality of the recording layer	79
32.1	Defects	79
32.2	Data errors	79
Section 7 - Characteristics of user data		80
33	Method of testing	80
33.1	Environment	80
33.2	Reference Drive	80
33.2.1	Optics and mechanics	80
33.2.2	Read power	80
33.2.3	Read channels	80
33.2.4	Error correction	80
33.2.5	Tracking	80
34	Minimum quality of a Recording Unit	81
34.1	Tracking	81
34.2	User-written data	81
Annex A - 80 mm +R disk		83
Annex B - Measurement of light reflectivity		87
Annex C - Measurement of birefringence		89
Annex D - Measuring conditions for operation signals		91
Annex E - Measurement of the differential phase tracking error		95
Annex F - The write pulse wave form for testing		99
Annex G - 8-to-16 Modulation		105
Annex H - Optimum Power Control and Recording Conditions		113
Annex I - Light fastness of the disk		117
Annex J - Wavelength dependency		119
Annex K - Running OPC		123
Annex L - Transportation		125
Annex M - Measurement of the groove wobble amplitude		127

Annex N - How to use the Physical format information in ADIP	129
Annex O - Values to be Implemented in Existing and Future Specifications	131

Section 1 - General

1 Scope

This Ecma Standard specifies the mechanical, physical and optical characteristics of 120 mm recordable optical disks with capacities of 4,7 Gbytes and 9,4 Gbytes. It specifies the quality of the recorded and unrecorded signals, the format of the data and the recording method, thereby allowing for information interchange by means of such disks. The data can be written once and read many times using a non-reversible method. These disks are identified as +R.

The +R system also allows 80 mm disks with capacities of 1,46 Gbytes and 2,92 Gbytes. These disks shall have the same characteristics as the 120 mm disks, except for some parameters related to the smaller dimensions. All parameters unique for the 80 mm disks are specified in Annex A.

This Ecma Standard specifies

- two related but different Types of this disk (see Clause 7),
- the conditions for conformance,
- the environments in which the disk is to be tested, operated and stored,
- the mechanical, physical and dimensional characteristics of the disk, so as to provide mechanical interchange between data processing systems,
- the format of the information on the disk, including the physical disposition of the tracks and sectors, the error correcting codes and the coding method,
- the characteristics of the signals recorded on the disk, thus enabling data processing systems to read the data from the disk.

This Ecma Standard provides for the interchange of disks between optical disk drives. Together with a standard for volume and file structure, it provides for full data interchange between data processing systems.

2 Conformance

2.1 Optical Disk

A claim of conformance with this Ecma Standard shall specify the Type implemented. An optical disk shall be in conformance with this Ecma Standard if it meets all mandatory requirements specified for its Type.

2.2 Generating system

A generating system shall be in conformance with this Ecma Standard if the optical disk it generates is in accordance with 2.1.

2.3 Receiving system

A receiving system shall be in conformance with this Ecma Standard if it is able to handle both Types of optical disk according to 2.1.

2.4 Compatibility statement

A claim of conformance by a Generating or Receiving system with this Ecma Standard shall include a statement listing any other standards supported. This statement shall specify the numbers of the standards, the optical disk types supported (where appropriate) and whether support includes reading only or both reading and writing.

3 References

ECMA-43	8-bit Coded Character Set Structure and Rules, Third Edition (1991) (ISO/IEC 4873)
ECMA-267	120 mm DVD – Read-Only Disk (1997)
ECMA-268	80 mm DVD – Read-Only Disk (1997)
ECMA-287	Safety of Electronic Equipment (1999)
ECMA-337	Data Interchange on 120 mm and 80 mm Optical Disk using +RW Format (2003)

4 Definitions

For the purpose of this Ecma Standard the following definitions apply:

4.1 Channel bit

The elements by which the binary values ZERO and ONE are represented by marks and spaces on the disk.

4.2 Clamping Zone

The annular part of the disk within which the clamping force is applied by the clamping device.

4.3 Digital Sum Value (DSV)

The arithmetic sum obtained from a bit stream by allocating the decimal value +1 to bits set to ONE and the decimal value –1 to bits set to ZERO.

4.4 Disk Reference Plane

A plane defined by the perfectly flat annular surface of an ideal spindle onto which the clamping Zone of the disk is clamped, and which is normal to the axis of rotation.

4.5 dummy substrate

A layer which may be transparent or not, provided for the mechanical support of the disk and, in some cases, of the recording layer as well.

4.6 entrance surface

The surface of the disk onto which the optical beam first impinges.

4.7 field

A subdivision of a sector.

4.8 groove

A trench-like feature of the disk, applied before the recording of any information, and used to define the track location. The groove is located nearer to the entrance surface than the so-called land in between the grooves. The recording is made on the groove.

4.9 interleaving

The process of reallocating the physical sequence of units of data so as to render the data more immune to burst errors.

4.10 mark

A non-reversible feature of the recording layer which may take the form of less reflective area, a pit, or any other type or form that can be sensed by the optical system. The pattern of marks and spaces represents the data on the disk.

4.11 Multi-session disk

A disk containing more than one set of Lead-in/Intro, Data, and Lead-out/Closure Zones.

4.12 Physical Sector

The smallest addressable part of a track in the Information Zone of a disk that can be accessed independently of other addressable parts of the Zone.

4.13 recording layer

A layer of the disk on which data is written during manufacture and / or use.

4.14 Reed-Solomon code (RS)

An error detection and / or correction code.

4.15 Single-session disk

A disk containing a Lead-in Zone, one Data Zone, and a Lead-out Zone.

4.16 session

A continuous part of the Information Zone of the disk consisting of a Lead-in or Intro Zone, a Data Zone and a Lead-out or Closure Zone.

4.17 space

A feature of the recording layer represented by any area between two marks which can be sensed by the optical system. The pattern of marks and spaces represents the data on the disk.

4.18 substrate

A transparent layer of the disk, provided for mechanical support of the recording layer, through which the optical beam accesses the recording layer.

4.19 track

A 360° turn of a continuous spiral.

4.20 track pitch

The distance between adjacent track centrelines, measured in a radial direction.

4.21 wobble

A continuous sinusoidal deviation of the track from the average centreline. Location information is included as phase modulated data in the wobble.

4.22 zone

An annular area of the disk.

5 Conventions and notations

5.1 Representation of numbers

A measured value is rounded off to the least significant digit of the corresponding specified value. For instance, it implies that a specified value of 1,26 with a positive tolerance of +0,01 and a negative tolerance of -0,02 allows a range of measured values from 1,235 to 1,274.

Numbers in decimal notations are represented by the digits 0 to 9.

Numbers in hexadecimal notation are represented by the hexadecimal digits 0 to 9 and A to F in parentheses.

The setting of bits is denoted by ZERO and ONE.

Numbers in binary notations and bit patterns are represented by strings of digits 0 and 1, with the most significant bit shown to the left. In a pattern of n bits, bit $b_{(n-1)}$ shall be the most significant bit (msb) and bit b_0 shall be the least significant bit (lsb). Bit $b_{(n-1)}$ shall be recorded first.

Negative values of numbers in binary notation are given as Two's complement.

In each data field, the data is recorded so that the most significant byte (MSB), identified as Byte 0, shall be recorded first and the least significant byte (LSB) last.

In a field of $8n$ bits, bit $b_{(8n-1)}$ shall be the most significant bit (msb) and bit b_0 the least significant bit (lsb). Bit $b_{(8n-1)}$ shall be recorded first.

5.2 Names

The names of entities, e.g. specific tracks, fields, etc., are given with an initial capital.

6 List of acronyms

a.c.	alternating current
ADIP	Address in Pre-groove
ASM	Asymmetry
BP	Byte Position
BPF	Band Pass Filter
CAV	Constant Angular Velocity
CLD	Constant Linear Density
CLV	Constant Linear Velocity
cm	current mark
d.c.	direct current
DCB	Disk Control Block
DCC	d.c. Component suppression Control
DSV	Digital Sum Value
ECC	Error Correction Code
EDC	Error Detection Code
EI	Extended Information
HF	High Frequency
ID	Identification Data
IED	ID Error Detection code
LPF	Low Pass filter
LSN	Logical Sector Number
lsb	Least Significant Bit
LSB	Least Significant Byte
msb	Most Significant Bit
MSB	Most Significant Byte
NA	Numerical Aperture
NRZ	Non Return to Zero
NRZI	Non Return to Zero Inverted
NSL	Normalized Slicing Level
NWPW	Normalized Write Power Window
OPC	Optimum Power Control
PAA	Physical Address in ADIP
PBS	Polarizing Beam Splitter
PI	Parity of Inner-code
PLL	Phase Locked Loop
PP	Push-Pull
pp	peak-to-peak
ps	previous space
PSN	Physical Sector Number

PO	Parity of Outer-code
RIN	Relative Intensity Noise
RS	Reed-Solomon code
RSV	Reserved (in use by specific applications)
RUN	Recording UNit
SDCB	Session DCB
SNR	Signal to Noise Ratio
SYNC	Synchronization code
TOC	Table of Contents

7 General description of the optical disk

The optical disk that is the subject of this Ecma Standard consists of two substrates bonded together by an adhesive layer, so that the recording layer(s) is (are) on the inside. The centring of the disk is performed on the edge of the centre hole of the assembled disk on the side currently accessed. Clamping is performed in the Clamping Zone. This Ecma Standard provides for two Types of such disks.

Type S consists of a substrate, a single recording layer and a dummy substrate. The recording layer can be accessed from one side only. The capacity is 4,7 Gbytes for the 120 mm sized disk and 1,46 Gbytes for the 80 mm sized disk.

Type D consists of two substrates and two recording layers. From each side of the disk only one of the recording layers can be accessed. The capacity is 9,4 Gbytes for the 120 mm sized disk and 2,92 Gbytes for the 80 mm sized disk.

Data can be written onto the disk as marks in the form of low-reflective spots in the recording layer with a focused optical beam. The data can be read with a focused optical beam, using the difference in the reflectivity between recorded marks and unrecorded spaces. The beam accesses the recording layer through a transparent substrate of the disk.

Figure 1 shows schematically the two Types.

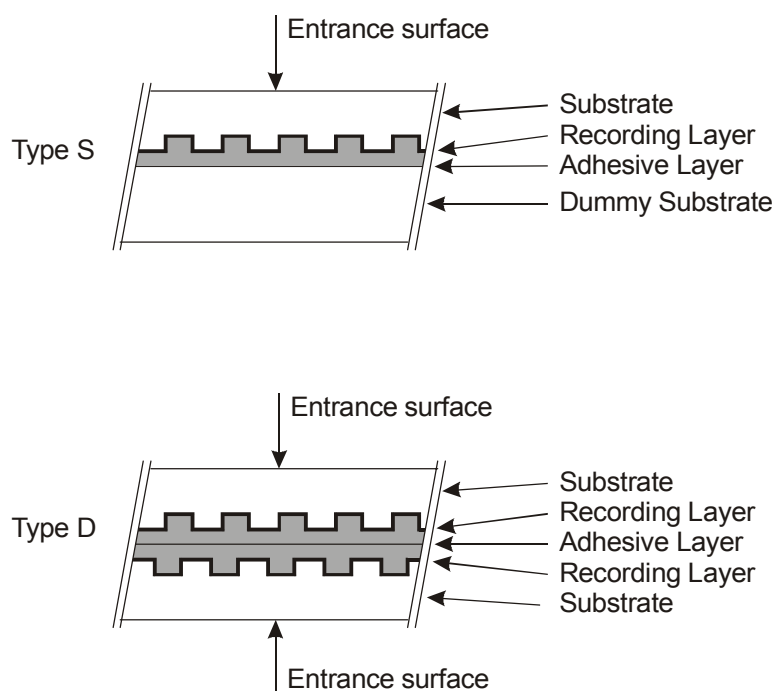

Figure 1 - Types of +R disk

8 General Requirements

8.1 Environments

8.1.1 Test environment

In the test environment, the air immediately surrounding the disk shall have the following properties:

temperature	: 23 °C ± 2 °C
relative humidity	: 45 % to 55 %
atmospheric pressure	: 60 kPa to 106 kPa

No condensation on the disk shall occur. Before testing, the disk shall be conditioned in this environment for 48 h minimum. It is recommended that, before testing, the entrance surface of the disk shall be cleaned according to the instructions of the manufacturer of the disk.

Unless otherwise stated, all tests and measurements shall be made in this test environment.

8.1.2 Operating environment

This Ecma Standard requires that a disk which meets all requirements of this Ecma Standard in the specified test environment shall provide data interchange over the specified ranges of environmental parameters in the operating environment.

The operating environment is the environment where the air immediately surrounding the disk shall have the following properties:

temperature	: 5 °C to 55 °C
relative humidity	: 3 % to 85 %
absolute humidity	: 1 g/m ³ to 30 g/m ³
atmospheric pressure	: 60 kPa to 106 kPa
temperature gradient	: 10 °C/h max.
relative humidity gradient	: 10 %/h max.

No condensation on the disk shall occur. If the disk has been exposed to conditions outside those specified in this Clause, it shall be acclimatized in an allowed operating environment for at least 2 h before use.

8.1.3 Storage environment

The storage environment is defined as the environment where the air immediately surrounding the disk shall have the following properties:

temperature	: -10 °C to 55 °C
relative humidity	: 3 % to 90 %
absolute humidity	: 1 g/m ³ to 30 g/m ³
atmospheric pressure	: 60 kPa to 106 kPa
temperature gradient	: 15 °C/h max.
relative humidity gradient	: 10 %/h max.

No condensation on the disk shall occur.

8.1.4 Transportation

This Ecma Standard does not specify requirements for transportation; guidance is given in Annex L.

8.2 Safety requirements

The disk shall satisfy the safety requirements of Standard ECMA-287, when used in the intended manner or in any foreseeable use in an information processing system.

8.3 Flammability

The disk and its components shall be made from materials that comply with the flammability class for HB materials, or better, as specified in Standard ECMA-287.

9 Reference Drive

The Reference Drive shall be used for the measurement of optical parameters for conformance with the requirements of this Ecma Standard. The critical components of this device have the characteristics specified in this Clause.

9.1 Optical system

The basic set-up of the optical system of the Reference Drive used for measuring the write and read parameters is shown in Figure 2. Different components and locations of components are permitted, provided that the performance remains the same as that of the set-up in Figure 2. The optical system shall be such that the detected light reflected from the entrance surface of the disk is minimized so as not to influence the accuracy of the measurements.

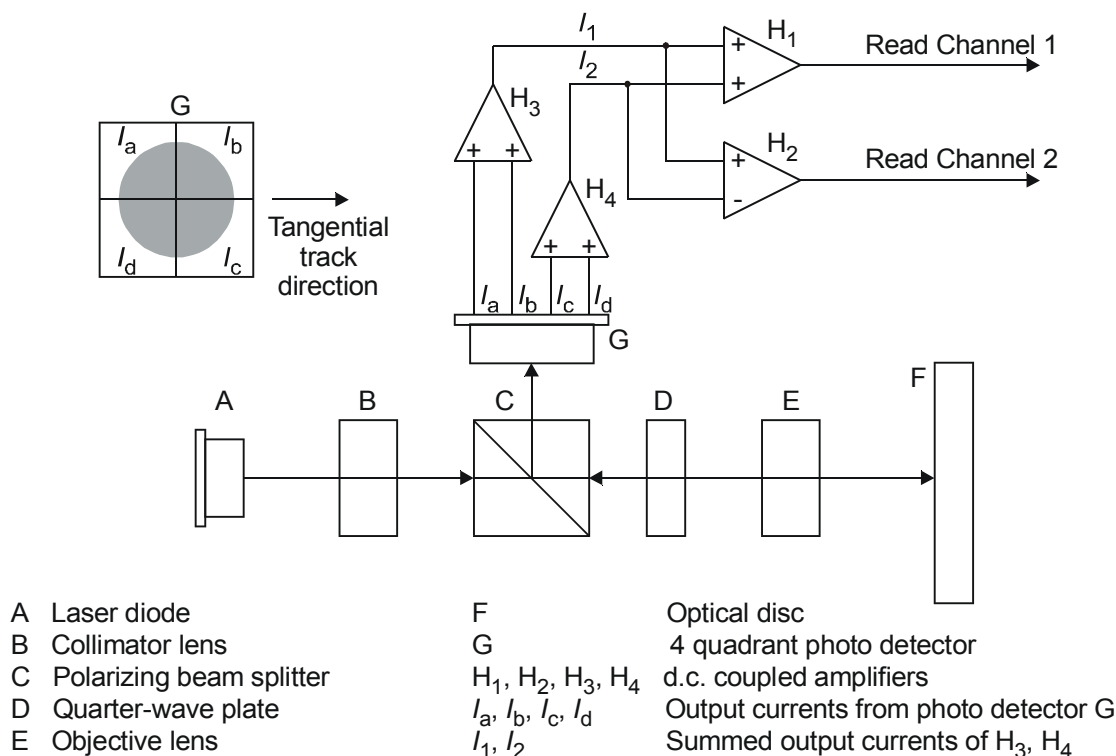

Figure 2 - Optical system of the Reference Drive

The combination of a polarizing beam splitter C and a quarter-wave plate D shall separate the entrance optical beam from the laser diode A and the reflected optical beam from the disk F. The beam splitter C shall have a p-s intensity reflectance ratio of at least 100.

9.2 Optical beam

The focused optical beam used for writing and reading data shall have the following properties:

- | | |
|--|---|
| a) Wavelength (λ) | 655 nm ^{+10 nm}
- 5 nm (see Annex J) |
| b) Numerical aperture of the objective lens (NA) | 0,65 ± 0,01 |
| c) The objective lens shall be compensated for spherical aberrations caused by a parallel substrate with nominal thickness (0,6 mm) and nominal refractive index (1,55). | |
| d) Wave front aberration | 0,033 × λ rms max. |
| e) Light intensity at the rim of the pupil of the objective lens | 35 % to 50 % of the maximum intensity in the radial direction and 45 % to 60 % in the tangential direction. |

- | | |
|---|---|
| f) Polarization of the light | Circular |
| g) Read power (average) | 0,7 mW ± 0,1 mW
(d.c. or HF modulated with a frequency >400 MHz) |
| h) Write power and pulse width | see Annex F |
| i) Relative Intensity Noise (RIN)* of the laser diode | -134 dB/Hz max. |
- *RIN (dB/Hz) = 10 log [(a.c. light power density / Hz) / d.c. light power]

9.3 Read channel 1

Read channel 1 shall be provided to generate signals from the marks and spaces in the recording layer. This Read channel shall be used for reading the user-written information, using the change in reflectivity of the marks and spaces. The read amplifiers after the photo detectors in the Read channel shall have a flat response within 1 dB from d.c. to 20 MHz.

For measurement of jitter, the characteristics of the PLL and the slicer, etc. are specified in Annex D.

9.4 Disk clamping

For measuring, the disk shall be clamped between two concentric rings covering most of the Clamping Zone (see 10.5). The top clamping area shall have the same diameters as the bottom clamping area (Figure 3). Clamping shall occur between

$$d_{in} = 22,3 \text{ mm} \begin{matrix} +0,5\text{mm} \\ -0,0\text{mm} \end{matrix}$$

and

$$d_{out} = 32,7 \text{ mm} \begin{matrix} +0,0\text{mm} \\ -0,5\text{mm} \end{matrix}$$

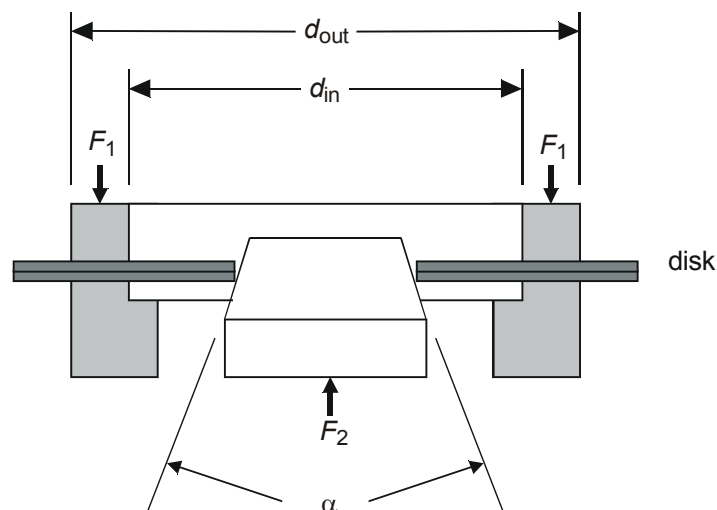

Figure 3 - Clamping and chucking conditions

The total clamping force shall be $F_1 = 2,0 \text{ N} \pm 0,5 \text{ N}$. In order to prevent warping of the disk under the moment of force generated by the clamping force and the chucking force F_2 exerted on the rim of the centre hole of the disk, F_2 shall not exceed 0,5 N (see Figure 3).

The tapered cone angle, α , shall be $40,0^\circ \pm 0,5^\circ$.

9.5 Rotation of the disk

The actual rotation speed for reading the disk shall be such that it results in the Reference velocity of 3,49 m/s \pm 0,03 m/s at the nominal Channel bit rate of 26,156 25 Mbit/s. The direction of rotation shall be counter-clockwise when viewed from the objective lens.

The actual rotation speed for writing the disk shall be such that it includes all Primary and Upper velocities for which parameters are specified in the Physical format information in the ADIP Aux Frames in the Lead-in Zone of the disk (see 14.4.1.1 and 14.4.2).

9.6 Wobble channel (Read channel 2)

Read channel 2 of the drive provides the wobble signals to control the access to addressed locations on the disk during writing. The wobble signal is generated in Read Channel 2 as a signal ($I_1 - I_2$) related to the difference in the amount of light in the two halves of the exit pupil of the objective lens. The read amplifiers after the photo detectors in the Read channel shall have a flat response within 1 dB from d.c. to 20 MHz.

9.7 Tracking channel (Read channel 2)

Read channel 2 of the drive provides the tracking error signals to control the servos for radial tracking of the optical beam. The radial tracking error is generated in Read Channel 2 as a signal ($I_1 - I_2$) related to the difference in the amount of light in the two halves of the exit pupil of the objective lens.

The method of generating the axial tracking error is not specified for the Reference Drive.

9.7.1 Normalized servo transfer function

The open-loop transfer function, $H_s(i\omega)$ for the axial and radial tracking servos is given by equation (1),

$$H_s(i\omega) = \frac{1}{3} \times \left(\frac{\omega_0}{i\omega} \right)^2 \times \frac{1 + \frac{3i\omega}{\omega_0}}{1 + \frac{i\omega}{3\omega_0}} \quad (1)$$

where

$$i = \sqrt{-1}$$

$$\omega = 2\pi f$$

$$\omega_0 = 2\pi f_0$$

and f_0 is the 0 dB crossover frequency of the open-loop transfer function.

The crossover frequencies of the lead-lag network of the servo are

$$\text{lead break frequency: } f_1 = f_0 / 3$$

$$\text{lag break frequency: } f_2 = f_0 \times 3$$

9.7.2 Reference Servo for Axial Tracking

The crossover frequency of the normalized servo transfer function (H_s) for axial tracking, $f_0 = \omega_0 / (2\pi)$ shall be given by equation (2), where α_{\max} shall be 1,5 times as large as the maximum expected axial acceleration of 8,0 m/s². The resulting tracking error e_{\max} from this α_{\max} shall be 0,20 μm .

Thus the crossover frequency f_0 shall be given by

$$f_0 = \frac{1}{2\pi} \sqrt{\frac{3 \times \alpha_{\max}}{e_{\max}}} = \frac{1}{2\pi} \sqrt{\frac{3 \times 8 \times 1,5}{0,20 \times 10^{-6}}} = 2,1 \text{ kHz} \quad (2)$$

For an open loop transfer function H of the Reference Servo for axial tracking, $|1+H|$ is limited as schematically shown by the shaded region of Figure 4.

Bandwidth from 100 Hz to 10 kHz

$|1+H|$ shall be within 20 % of $|1+H_s|$.

Bandwidth from 26 Hz to 100 Hz

$|1+H|$ shall be within the limits enclosed by the following four points.

- 1) 41,7 dB at 100 Hz ($|1+H_s|$ at 100 Hz – 20 %)
- 2) 45,2 dB at 100 Hz ($|1+H_s|$ at 100 Hz + 20 %)
- 3) 65,1 dB at 26 Hz ($|1+H_s|$ at 26 Hz – 20 %)
- 4) 85,1 dB at 26 Hz ($|1+H_s|$ at 26 Hz – 20 % + 20 dB)

Bandwidth from 9,5 Hz to 26 Hz

$|1+H|$ shall be between 65,1 dB and 85,1 dB.

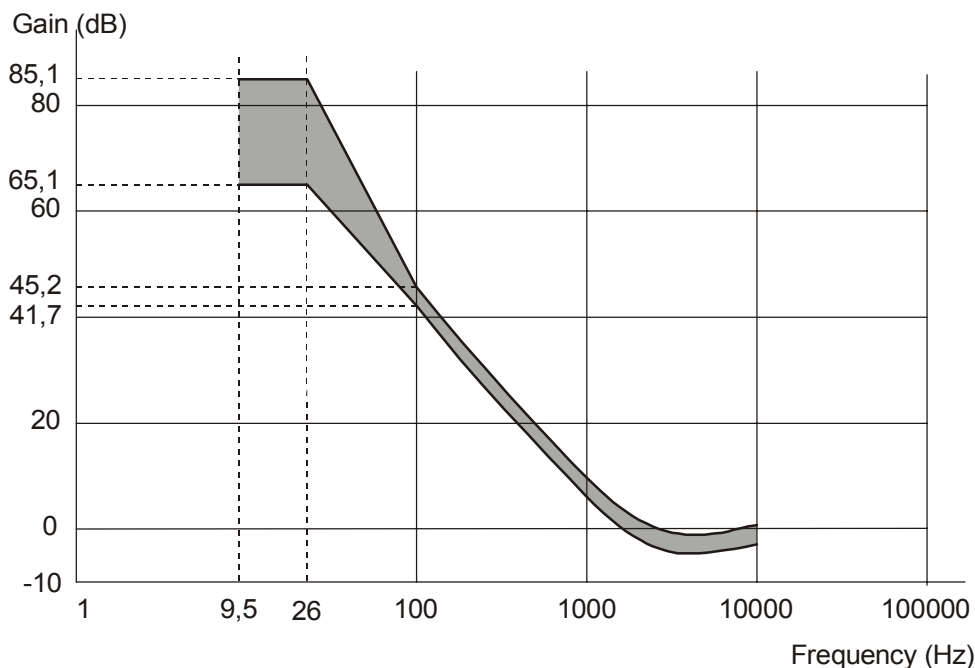

Figure 4 - Reference servo for axial tracking

9.7.3 Reference Servo for Radial Tracking

The crossover frequency of the normalized servo transfer function (H_s) for radial tracking $f_0 = \omega_0 / (2\pi)$ shall be given by equation (3), where α_{\max} shall be 1,5 times as large as the maximum expected radial acceleration of 1,1 m/s². The resulting tracking error e_{\max} from this α_{\max} shall be 0,022 μm .

Thus the crossover frequency f_0 shall be given by

$$f_0 = \frac{1}{2\pi} \sqrt{\frac{3 \times \alpha_{\max}}{e_{\max}}} = \frac{1}{2\pi} \sqrt{\frac{3 \times 1,1 \times 1,5}{0,022 \times 10^{-6}}} = 2,4 \text{ kHz} \quad (3)$$

For an open loop transfer function H of the Reference Servo for radial tracking, $|1+H|$ is limited as schematically shown by the shaded region of Figure 5.

Bandwidth from 100 Hz to 10 kHz

$|1+H|$ shall be within 20 % of $|1+H_s|$.

Bandwidth from 28,2 Hz to 100 Hz

$|1+H|$ shall be within the limits enclosed by the following four points.

- 1) 43,7 dB at 100 Hz ($|1+H_s|$ at 100 Hz – 20 %)
- 2) 47,2 dB at 100 Hz ($|1+H_s|$ at 100 Hz + 20 %)
- 3) 65,6 dB at 28,2 Hz ($|1+H_s|$ at 28,2 Hz – 20 %)
- 4) 85,6 dB at 28,2 Hz ($|1+H_s|$ at 28,2 Hz – 20 % + 20 dB)

Bandwidth from 9,5 Hz to 28,2 Hz

$|1+H|$ shall be between 65,6 dB and 85,6 dB.

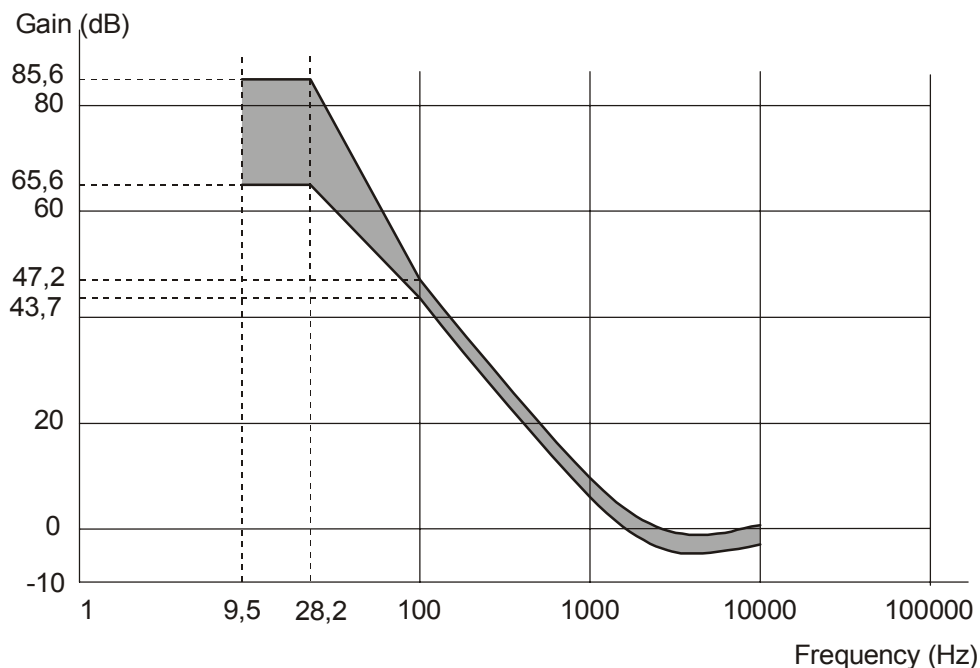

Figure 5 - Reference servo for radial tracking

Section 2 - Dimensional, mechanical and physical characteristics of the disk

10 Dimensional characteristics

Dimensional characteristics are specified for those parameters deemed mandatory for interchange and compatible use of the disk. Where there is freedom of design, only the functional characteristics of the elements described are indicated. The enclosed drawing, Figure 7 shows the dimensional requirements in summarized form. The different parts of the disk are described from the centre hole to the outside rim.

10.1 Reference Planes

The dimensions are referred to two Reference Planes P and Q.

Reference Plane P is the primary Reference Plane. It is the plane on which the bottom surface of the Clamping Zone rests (see 10.5).

Reference Plane Q is the plane parallel to Reference Plane P at the height of the top surface of the Clamping Zone.

10.2 Overall dimensions

The disk shall have an overall diameter (see also Annex A)

$$d_1 = 120,00 \text{ mm} \pm 0,30 \text{ mm}$$

The centre hole of a substrate or a dummy substrate shall have a diameter (see Figure 6)

$$d_{\text{substrate}} = 15,00 \text{ mm} \begin{matrix} +0,15\text{mm} \\ -0,00\text{mm} \end{matrix}$$

The hole of an assembled disk, i.e. with both parts bonded together, shall have a diameter

$$d_2 = 15,00 \text{ mm min.}$$

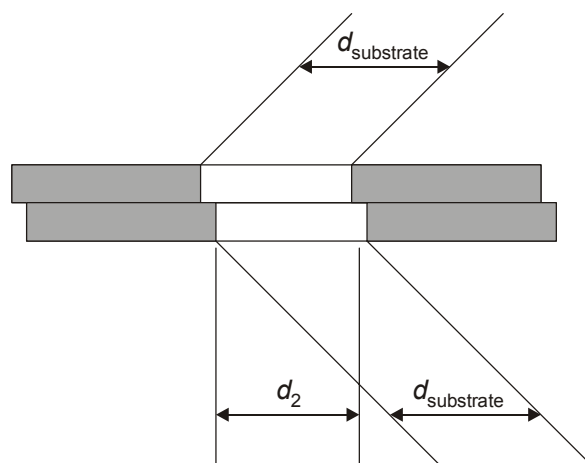

Figure 6 - Hole diameters for an assembled disk

The corners of the centre hole shall be free of any burrs or sharp features and shall be rounded off or chamfered by

$$h_5 = 0,1 \text{ mm max.}$$

The thickness of the disk shall be

$$e_1 = 1,20 \text{ mm} \begin{matrix} +0,30\text{mm} \\ -0,06\text{mm} \end{matrix}$$

10.3 First transition area

In the area defined by d_2 and

$$d_3 = 16,0 \text{ mm min.}$$

the surface of the disk is permitted to be above Reference Plane P and/or below Reference Plane Q by 0,10 mm max.

10.4 Second transition area

This area shall extend between diameter d_3 and diameter

$$d_4 = 22,0 \text{ mm max.}$$

In this area the disk may have an uneven surface or burrs up to 0,05 mm max. beyond Reference Planes P and/or Q.

10.5 Clamping Zone

This Zone shall extend between diameter d_4 and diameter

$$d_5 = 33,0 \text{ mm min.}$$

Each side of the Clamping Zone shall be flat within 0,1 mm. The top side of the Clamping Zone, i.e. that of Reference Plane Q shall be parallel to the bottom side, i.e. that of Reference Plane P within 0,1 mm.

In the Clamping Zone the thickness e_2 of the disk shall be

$$e_2 = 1,20 \text{ mm} \begin{matrix} +0,20\text{mm} \\ -0,10\text{mm} \end{matrix}$$

10.6 Third transition area

This area shall extend between diameter d_5 and diameter

$$d_6 = 44,0 \text{ mm max.}$$

In this area the top surface is permitted to be above Reference Plane Q by

$$h_1 = 0,25 \text{ mm max.}$$

or below Reference Plane Q by

$$h_2 = 0,10 \text{ mm max.}$$

The bottom surface is permitted to be above Reference Plane P by

$$h_3 = 0,10 \text{ mm max.}$$

or below Reference Plane P by

$$h_4 = 0,25 \text{ mm max.}$$

10.7 Information Zone

The Information Zone shall extend from diameter d_6 to diameter (see also Annex A)

$$d_7 = 117,5 \text{ mm min.}$$

This Zone consists of the Lead-in Zone, the Data Zone, the Lead-out Zone and the Inner and Outer Drive Areas (see also Clause 15).

10.8 Rim Area

The rim area is that area extending from diameter d_7 to diameter d_1 . In this area the surfaces are permitted to both extend beyond Reference Plane Q or Reference Plane P

$$h_6 = 0,1 \text{ mm max.}$$

The outer corners of the disk shall be free of any burrs or sharp features and shall be rounded off or chamfered by

$$h_7 = 0,2 \text{ mm max.}$$

10.9 Remark on tolerances

All heights specified in the preceding clauses and indicated by h_i are independent from each other. This means that, for example, if the top surface of the third transition area is below Reference Plane Q by up to h_2 , there is no implication that the bottom surface of this area has to be above Reference Plane P by up to h_3 . Where dimensions have the same - generally maximum - numerical value, this does not imply that the actual values have to be identical.

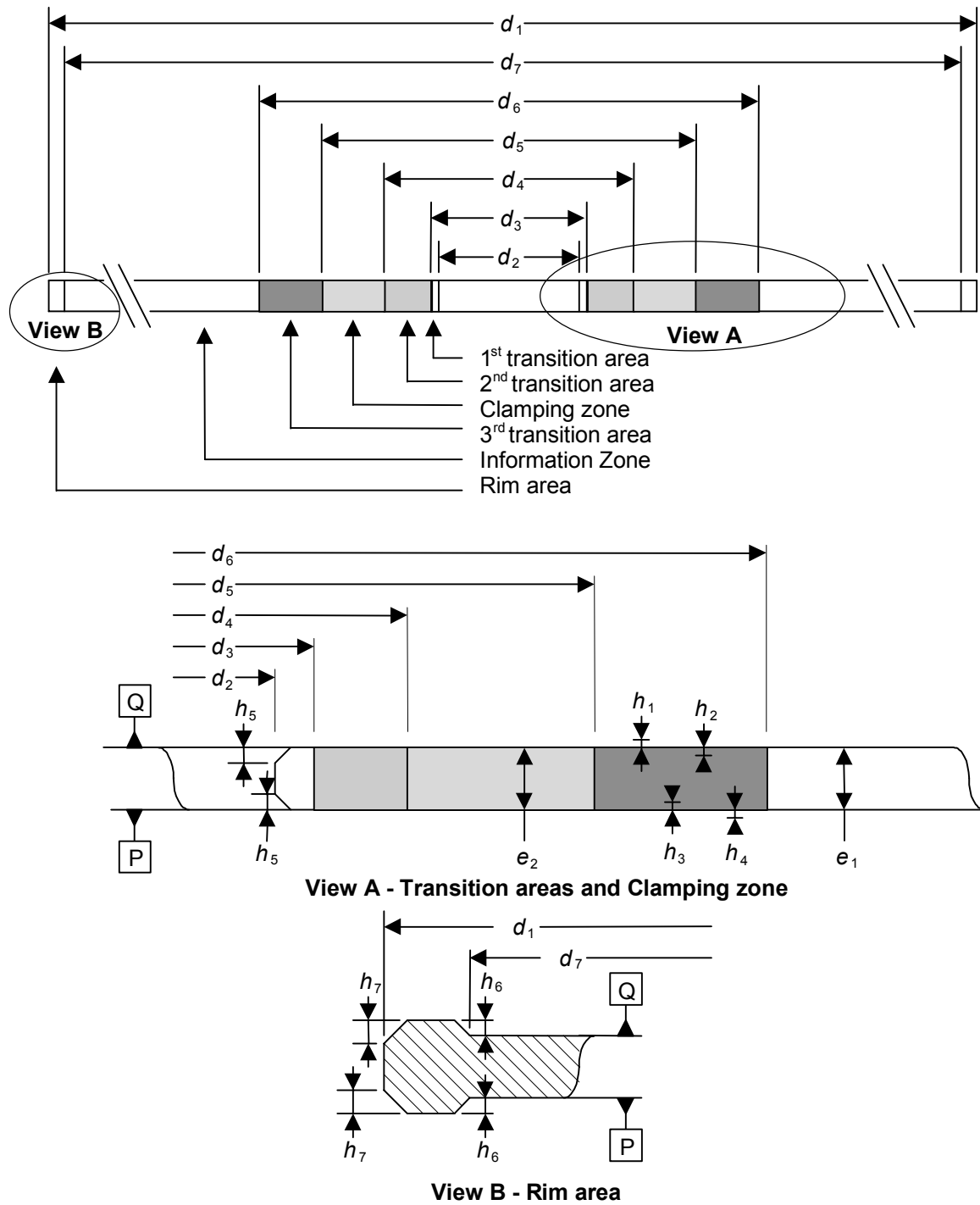

Figure 7 - Physical disk dimensions

11 Mechanical characteristics

11.1 Mass

The mass of the disk shall be in the range of 13,0 g to 20,0 g (see also Annex A).

11.2 Moment of inertia

The moment of inertia of the disk, relative to its rotation axis, shall not exceed 0,040 g·m² (see also Annex A).

11.3 Dynamic imbalance

The dynamic imbalance of the disk, relative to its rotation axis, shall not exceed 2,5 g·mm (see also Annex A).

11.4 Axial runout

When measured by the optical system with the Reference Servo for axial tracking, the disk rotating at the Reference velocity of 3,49 m/s (see 9.5), the deviation of the recording layer from its nominal position in the direction normal to the Reference Planes shall not exceed 0,3 mm.

The residual tracking error below 10 kHz, measured using the Reference Servo for axial tracking and the disk rotating at the Reference velocity, shall not exceed 0,13 μm.

The measuring filter shall be a Butterworth LPF,

f_c (-3 dB): 10 kHz, with slope : -80 dB/decade.

11.5 Radial runout

The runout of the outer edge of the disk shall not exceed 0,3 mm peak-to-peak.

The radial runout of tracks shall not exceed 70 μm peak-to-peak.

The residual tracking error below 1,1 kHz, measured using the Reference Servo for radial tracking and the disk rotating at the Reference velocity of 3,49 m/s (see 9.5), shall not exceed 0,015 μm.

The measuring filter shall be a Butterworth LPF,

f_c (-3 dB) : 1,1 kHz, with slope : -80 dB/decade.

The rms noise value of the residual error signal in the frequency band from 1,1 kHz to 10 kHz, measured with an integration time of 20 ms, using the Reference Servo for radial tracking, shall not exceed 0,016 μm.

The measuring filter shall be a Butterworth BPF,

frequency range (-3 dB) : 1,1 kHz, with slope : +80 dB/decade
to : 10 kHz, with slope : -80 dB/decade.

12 Optical characteristics in the Information Zone

12.1 Index of refraction

The index of refraction of the substrate in the Information Zone shall be $1,55 \pm 0,10$.

12.2 Thickness of the substrate

The thickness of the substrate, from the entrance surface to the recording layer, varies with the index of refraction of the substrate and shall be defined as the enclosed region in Figure 8.

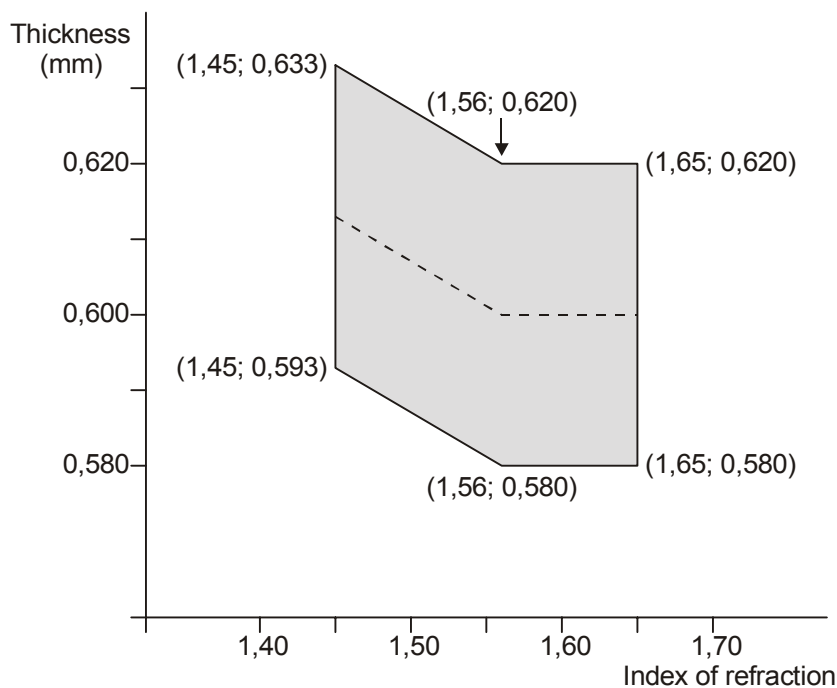

Figure 8 - Thickness of the substrate

12.3 Reflectivity

The double-pass optical transmission of the substrate and the reflectivity of the recording layer are measured together as the reflectivity R of the disk. When measured according to Annex B the value of R shall be

in the Information Zone $45 \% \leq R_d \leq 85 \%$ in the unrecorded groove
 $45 \% \leq R_{14H} \leq 85 \%$ in the recorded groove

The product of the reflectivity of the unrecorded groove R_d and the optimized write power P_{peak} for the write strategy concerned (see 29.3.2) shall fulfil the following requirement:

$$R_d \times \text{actual } P_{peak} \leq \frac{P_{peak_max} \text{ for } \lambda \leq \lambda_{IND} \text{ for write strategy concerned (mW)}}{15} \times 9 \text{ mW}$$

12.4 Birefringence

The birefringence of the substrate shall not exceed 60 nm when measured according to Annex C.

12.5 Angular deviation

The angular deviation is the angle α between a parallel incident beam perpendicular to the Reference Plane P and the reflected beam (see Figure 9). The incident beam shall have a diameter in the range 0,3 mm to 3,0 mm. This angle α includes deflection due to the entrance surface and to the unparallelism of the recording layer with the entrance surface.

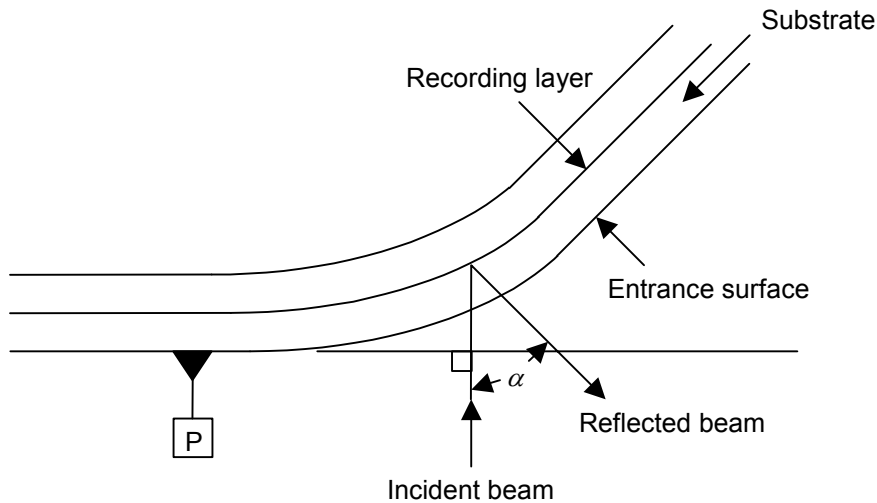

Figure 9 - Angular deviation α

The angular deviation shall be

In radial direction : $|\alpha| = 0,70^\circ \text{ max.}$

The variation of α in radial direction over one revolution shall be $0,80^\circ \text{ peak-to-peak max.}$

In tangential direction : $|\alpha| = 0,30^\circ \text{ max.}$

Section 3 - Format of information

13 Data format

The data received from the host, called Main Data, is formatted in a number of steps before being recorded on the disk.

It is transformed successively into

- a Data Frame,
- a Scrambled Frame,
- an ECC Block,
- 16 Recording Frames,
- 16 Physical Sectors,
- a Recording Unit.

These steps are specified in the following clauses.

13.1 Data Frames

A Data Frame shall consist of 2 048 bytes arranged in an array of 12 rows each containing 172 bytes (Figure 10). The first row shall start with three fields, called Identification Data (ID), ID Error Detection Code (IED), and RSV bytes, followed by 160 Main Data bytes. The next 10 rows shall each contain 172 Main Data bytes, and the last row shall contain 168 Main Data bytes followed by four bytes for recording an Error Detection Code (EDC). The 2 048 Main Data bytes are identified as D_0 to $D_{2\ 047}$.

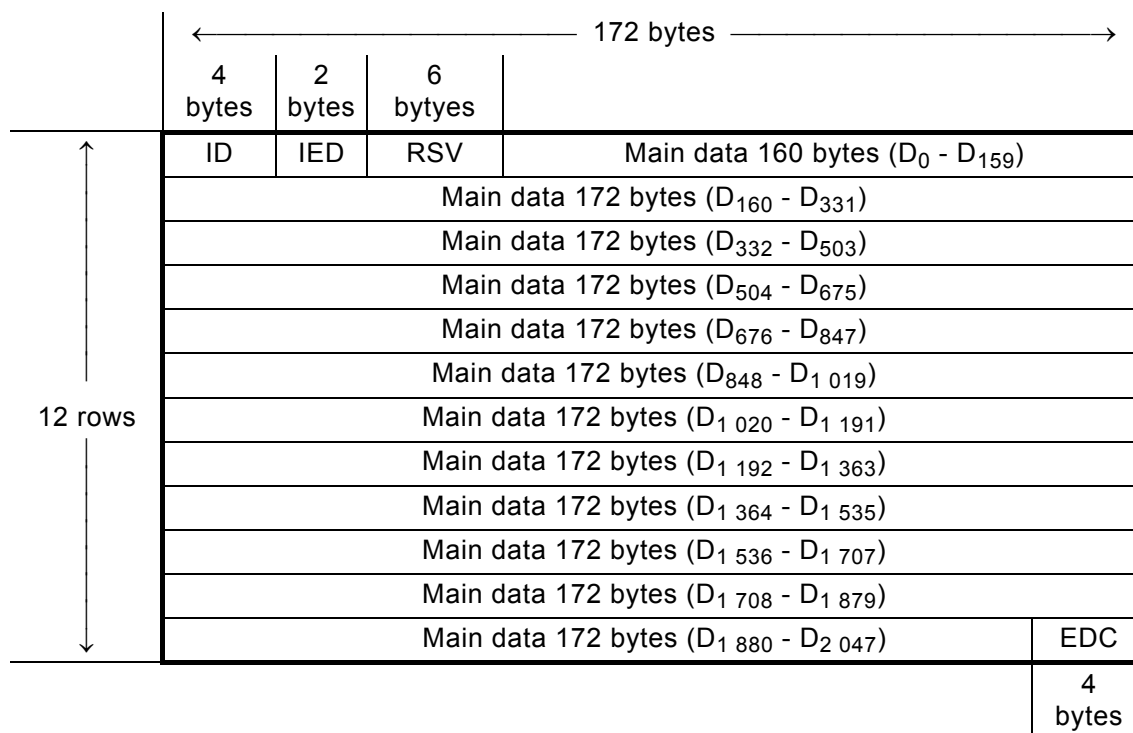

Figure 10 - Data Frame

13.1.1 Identification Data (ID)

This field shall consist of four bytes, the bits of which are numbered consecutively from b_0 (lsb) to b_{31} (msb), see Figure 11.

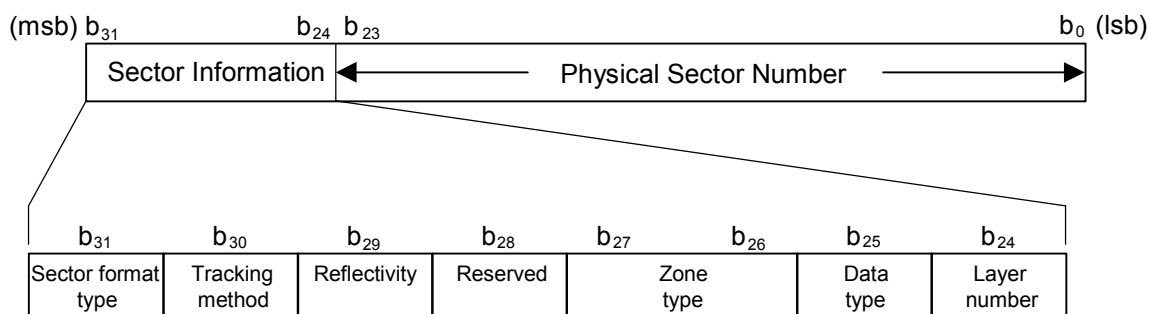

Figure 11 - Identification Data (ID)

The bits of the most significant byte, the Sector Information, shall be set as follows:

- Bit b_{31} shall be set to ZERO, indicating a CLD format
- Bit b_{30} shall be set to ZERO, indicating pit tracking capability (see 31.2.5)
- Bit b_{29} shall be set to ZERO indicating that the reflectivity is greater than 40 %
- Bit b_{28} shall be set to ZERO
- Bits b_{27} to b_{26} shall be set to
 ZERO ZERO in the Data Zone
 ZERO ONE in the Lead-in Zone
 ONE ZERO in the Lead-out Zone
- Bit b_{25} shall be set to ZERO, indicating read only data.
- Bit b_{24} shall be set to ZERO, indicating that through an entrance surface only one recording layer can be accessed

The least significant three bytes, bits b_{23} to b_0 , shall specify the Physical Sector Number in binary notation. The Physical Sector Number of the first Physical Sector of an ECC Block shall be an integer multiple of 16.

13.1.2 ID Error Detection Code (IED)

When identifying all bytes of the array shown in Figure 10 as $C_{i,j}$ for $i = 0$ to 11 and $j = 0$ to 171, the bytes of IED are represented by $C_{0,j}$ for $j = 4$ to 5. Their setting is obtained as follows.

$$IED(x) = \sum_{j=4}^5 C_{0,j} x^{5-j} = I(x) x^2 \text{ mod } G_E(x)$$

where

$$I(x) = \sum_{j=0}^3 C_{0,j} x^{3-j} \quad \text{and} \quad G_E(x) = (x + 1)(x + \alpha)$$

α is the primitive root of the primitive polynomial $P(x) = x^8 + x^4 + x^3 + x^2 + 1$

13.1.3 RSV

This field shall consist of 6 bytes. The first byte can be set by the application. If not specified by the application, it is reserved and shall be set to (00). The remaining 5 bytes are reserved and shall all be set to (00).

Under no circumstance may other data received from the host be recorded in this field.

Circumvention: Recorders and recording drives shall be considered as circumvention devices when these are produced to record, or can easily be modified to record, in any manner, a user-defined number in this field.

13.1.4 Error Detection Code (EDC)

This 4-byte field shall contain the parities of an Error Detection Code computed over the preceding 2 060 bytes of the Data Frame. Considering the Data Frame as a single bit field starting with the most significant bit of the first byte of the ID field and ending with the least significant bit of the EDC field, then this msb will be $b_{16\ 511}$ and the lsb will be b_0 . Each bit b_i of the EDC is shown as follows for $i = 0$ to 31:

$$EDC(x) = \sum_{i=0}^{31} b_i x^i = l(x) \bmod G(x)$$

where

$$l(x) = \sum_{i=32}^{16\ 511} b_i x^i \quad \text{and} \quad G(x) = x^{32} + x^{31} + x^4 + 1$$

13.2 Scrambled Frames

The 2 048 Main Data bytes shall be scrambled by means of the circuit shown in Figure 12 which shall consist of a feedback bit shift register in which bits r_7 (msb) to r_0 (lsb) represent a scrambling byte at each 8-bit shift. At the beginning of the scrambling procedure of a Data Frame, positions r_{14} to r_0 shall be pre-set to the value(s) specified in Table 1 (the msb of the pre-set value shall be discarded). The same pre-set value shall be used for 16 consecutive Data Frames. After 16 groups of 16 Data Frames, the sequence is repeated. The initial pre-set number is equal to the value represented by bits b_7 (msb) to b_4 (lsb) of the ID field of the Data Frame. Table 1 specifies the initial pre-set value of the shift register corresponding to the 16 initial pre-set numbers.

Table 1 - Initial values of the shift register

Initial pre-set number	Initial pre-set value	Initial pre-set number	Initial pre-set value
(0)	(0001)	(8)	(0010)
(1)	(5500)	(9)	(5000)
(2)	(0002)	(A)	(0020)
(3)	(2A00)	(B)	(2001)
(4)	(0004)	(C)	(0040)
(5)	(5400)	(D)	(4002)
(6)	(0008)	(E)	(0080)
(7)	(2800)	(F)	(0005)

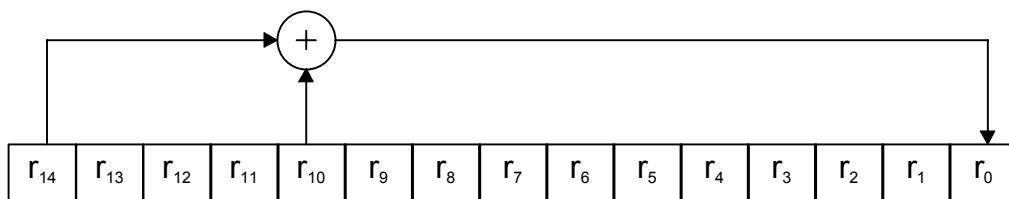

Figure 12 - Feedback shift register

The part of the initial value of r_7 to r_0 is taken out as scrambling byte S_0 . After that, an 8-bit shift is repeated 2 047 times and the following 2 047 bytes shall be taken from r_7 to r_0 as scrambling bytes S_1 to $S_{2\,047}$. The Main Data bytes D_k of the Data Frame become scrambled bytes D'_k where

$$D'_k = D_k \oplus S_k \quad \text{for } k = 0 \text{ to } 2\,047$$

\oplus stands for Exclusive OR

13.3 ECC Blocks

An ECC Block is formed by arranging 16 consecutive Scrambled Frames in an array of 192 rows of 172 bytes each (Figure 13). To each of the 172 columns 16 bytes of Parity of Outer Code are added, then, to each of the resulting 208 rows, 10 bytes of Parity of Inner Code are added. Thus a complete ECC Block comprises 208 rows of 182 bytes each. The bytes of this array are identified as $B_{i,j}$ as follows, where i is the row number and j is the column number.

$B_{i,j}$ for $i = 0$ to 191 and $j = 0$ to 171 are bytes from the Scrambled Frames

$B_{i,j}$ for $i = 192$ to 207 and $j = 0$ to 171 are bytes of the Parity of Outer Code

$B_{i,j}$ for $i = 0$ to 207 and $j = 172$ to 181 are bytes of the Parity of Inner Code

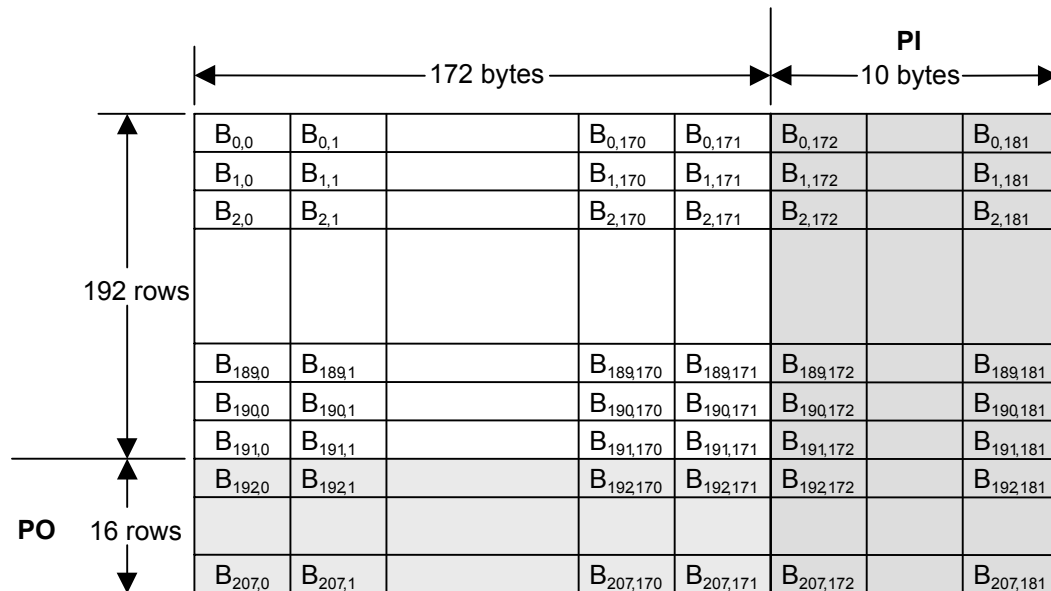

Figure 13 - ECC Block

The PO and PI bytes shall be obtained as follows.

In each of columns $j = 0$ to 171, the 16 PO bytes are defined by the remainder polynomial $R_j(x)$ to form the outer code RS(208,192,17).

$$R_j(x) = \sum_{i=192}^{207} B_{i,j} x^{207-i} = I_j(x) x^{16} \text{ mod } G_{PO}(x)$$

where

$$I_j(x) = \sum_{i=0}^{191} B_{i,j} x^{191-i} \quad \text{and} \quad G_{PO}(x) = \prod_{k=0}^{15} (x + \alpha^k)$$

In each of rows $i = 0$ to 207, the 10 PI bytes are defined by the remainder polynomial $R_i(x)$ to form the inner code RS(182,172,11).

$$R_i(x) = \sum_{j=172}^{181} B_{i,j} x^{181-j} = l_i(x) x^{10} \text{ mod } G_{PI}(x)$$

where

$$l_i(x) = \sum_{j=0}^{171} B_{i,j} x^{171-j} \quad \text{and} \quad G_{PI}(x) = \prod_{k=0}^9 (x + \alpha^k)$$

α is the primitive root of the primitive polynomial $P(x) = x^8 + x^4 + x^3 + x^2 + 1$

13.4 Recording Frames

Sixteen Recording Frames shall be obtained by interleaving one of the 16 PO rows at a time after every 12 rows of an ECC Block (Figure 14). This is achieved by re-locating the bytes $B_{i,j}$ of the ECC Block as $B_{m,n}$ for

$$m = i + \text{int} [i / 12] \quad \text{and} \quad n = j \quad \text{for } i \leq 191$$

$$m = 13 \times (i - 191) - 1 \quad \text{and} \quad n = j \quad \text{for } i \geq 192$$

where $\text{int} [x]$ represents the largest integer not greater than x .

Thus the 37 856 bytes of an ECC Block are re-arranged into 16 Recording Frames of 2 366 bytes. Each Recording Frame consists of an array of 13 rows of 182 bytes.

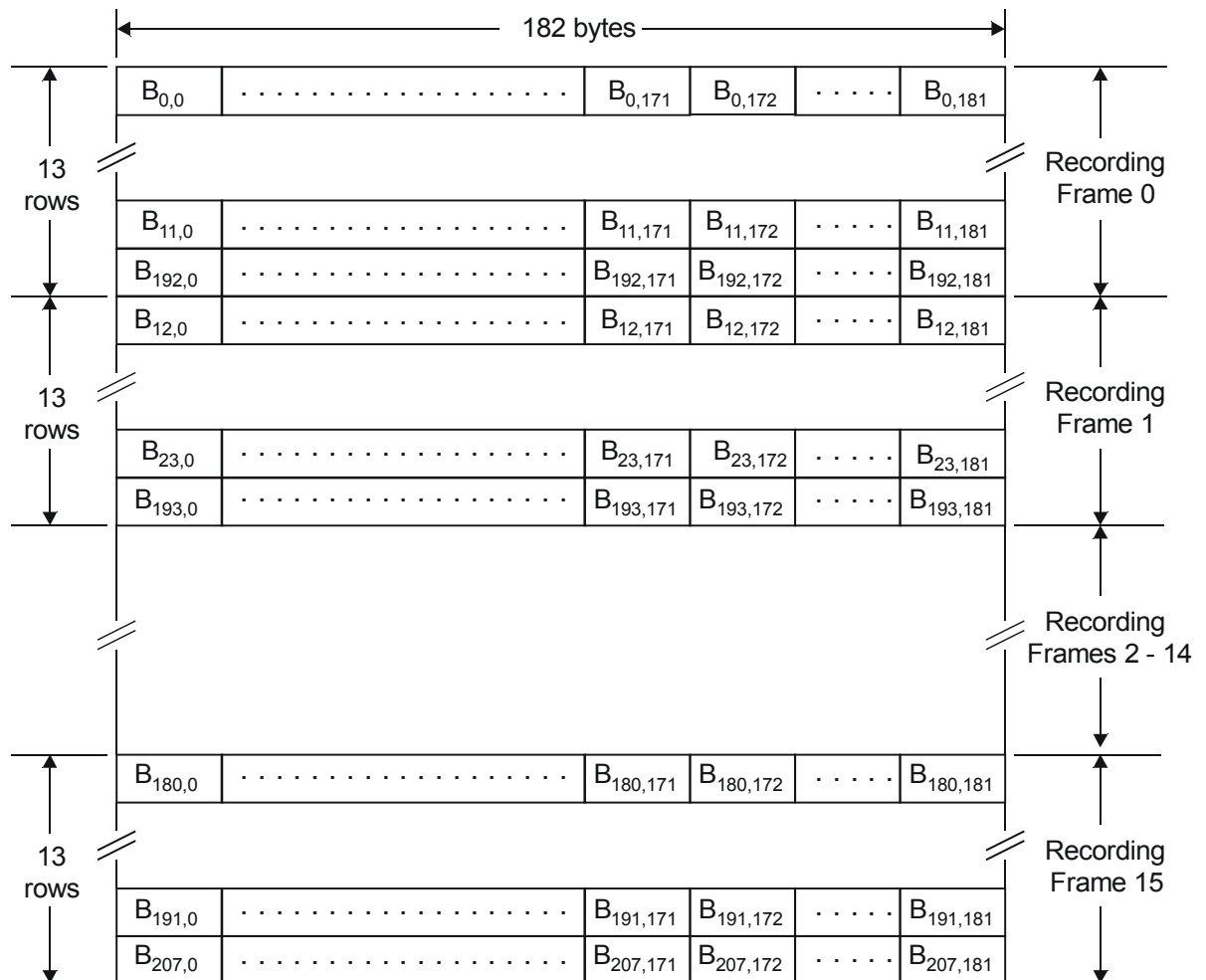

Figure 14 - Recording Frames obtained from an ECC Block

13.5 Modulation and NRZI conversion

The 8-bit bytes of each Recording Frame shall be transformed into 16-bit Code Words with the run length limitation that between 2 ONEs there shall be at least 2 ZEROs and at most 10 ZEROs (RLL(2,10)). Annex G specifies the conversion tables to be applied. The Main Conversion table and the Substitution table specify a 16-bit Code Word for each 256 8-bit bytes with one of 4 States. For each 8-bit byte, the tables indicate the corresponding Code Word, as well as the State for the next 8-bit byte to be encoded.

The 16-bit Code Words shall be NRZI-converted into Channel bits before recording on the disk (see Figure 15). The Channel clock period is the time between 2 consecutive Channel bits.

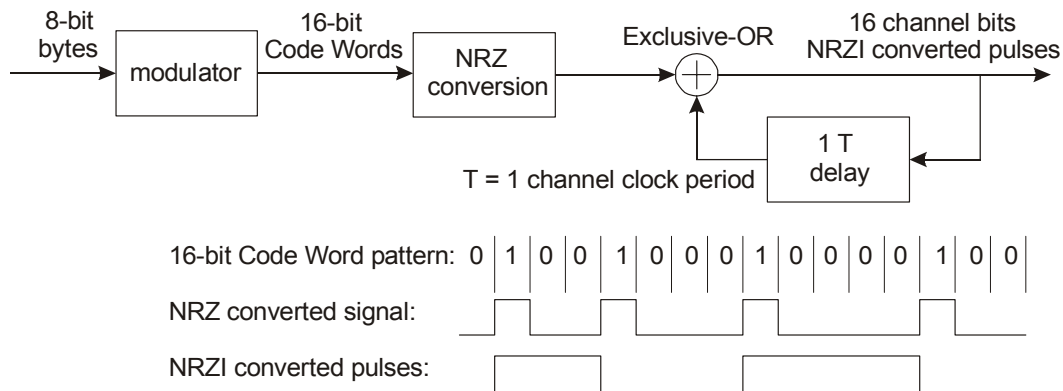

Figure 15 - NRZI conversion

13.6 Physical Sectors

The structure of a Physical Sector is shown in Figure 16. It shall consist of 13 rows, each comprising two Sync Frames. A Sync Frame shall consist of a SYNC Code from Table 2 and 1 456 Channel bits representing 91 8-bit bytes. Each row of the Physical Sector shall consist of two Sync Frames with the first 1 456 Channel bits representing the first 91 bytes of each row of a Recording Frame and the second 1 456 Channel bits representing the second 91 bytes of each row of a Recording Frame.

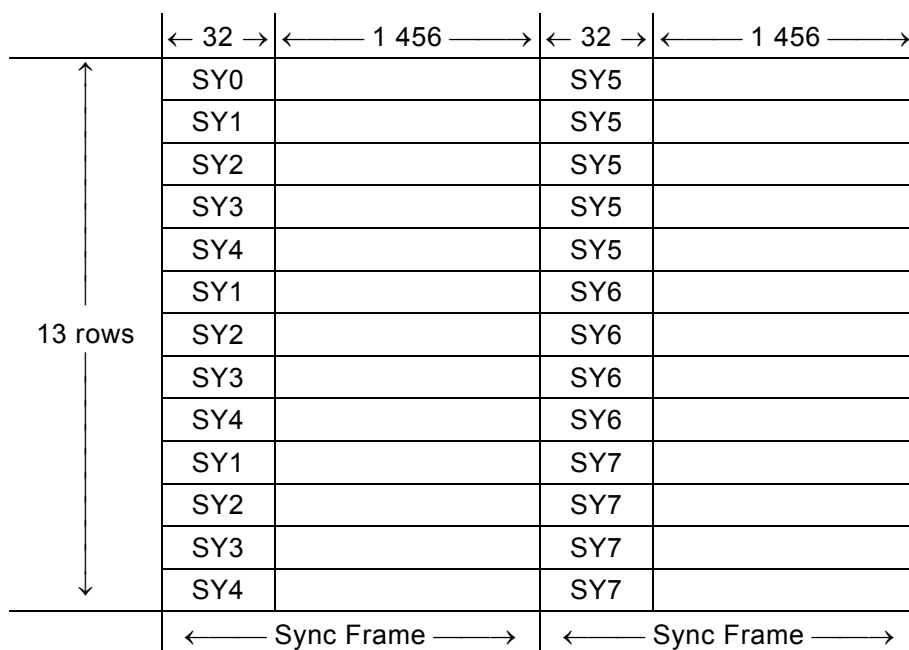

Figure 16 - Physical Sector

Recording of the Physical Sector shall start with the first Sync Frame of the first row, followed by the second Sync Frame of that row, and so on, row-by-row. The state of each SYNC Code and each subsequent set of 16 Channel bits shall follow the rules defined in 13.8.

Table 2 - SYNC Codes

State 1 and State 2 (next state is state 1)			
Primary SYNC codes		Secondary SYNC codes	
(msb)	(lsb)	(msb)	(lsb)
SY0 = 0001001001000100	0000000000010001	/	0001001000000100 0000000000010001
SY1 = 0000010000000100	0000000000010001	/	0000010001000100 0000000000010001
SY2 = 0001000000000100	0000000000010001	/	0001000001000100 0000000000010001
SY3 = 0000100000000100	0000000000010001	/	0000100001000100 0000000000010001
SY4 = 0010000000000100	0000000000010001	/	0010000001000100 0000000000010001
SY5 = 0010001001000100	0000000000010001	/	0010001000000100 0000000000010001
SY6 = 0010010010000100	0000000000010001	/	0010000010000100 0000000000010001
SY7 = 0010010001000100	0000000000010001	/	0010010000000100 0000000000010001
State 3 and State 4 (next state is state 1)			
Primary SYNC codes		Secondary SYNC codes	
(msb)	(lsb)	(msb)	(lsb)
SY0 = 1001001000000100	0000000000010001	/	1001001001000100 0000000000010001
SY1 = 1000010001000100	0000000000010001	/	1000010000000100 0000000000010001
SY2 = 1001000001000100	0000000000010001	/	1001000000000100 0000000000010001
SY3 = 1000001001000100	0000000000010001	/	1000001000000100 0000000000010001
SY4 = 1000100001000100	0000000000010001	/	1000100000000100 0000000000010001
SY5 = 1000100100000100	0000000000010001	/	1000000100000100 0000000000010001
SY6 = 1001000010000100	0000000000010001	/	1000000010000100 0000000000010001
SY7 = 1000100010000100	0000000000010001	/	1000000010000100 0000000000010001

13.7 Layout of a Recording Unit (RUN)

A RUN shall consist of an integer number ($M \geq 1$) of sets of 16 Physical Sectors, each from a single ECC Block. The M ECC Blocks shall be preceded by 8 Channel bits, which are meant to reduce possible influences of inaccuracies of the linking point, while the last 8 Channel bits of the last Physical Sector shall be discarded at recording. The 8 linking Channel bits and the next SYNC Code SY0 (chosen from State 1/2 or State 3/4) shall be chosen randomly, such that the runlength constraints specified in 13.5 are fulfilled.

Each RUN of M ECC Blocks ($M \geq 1$) starting with ECC Block N shall be recorded in the following way:

- 8 Channel bits for linking in ECC Block $N-1$,
- full ECC Blocks N to $N + M - 2$ (if $M \geq 2$),
- ECC Block $N + M - 1$, except for the last 8 Channel bits, which bits shall not be recorded.

The positioning of a Recording Unit is shown in Figure 17.

When the RUN starting with ECC Block N is to be recorded, and ECC Block $N-1$ has not yet been recorded, then the RUN shall be extended with a dummy ECC Block $N-1$ of which all Main Data bytes shall be set to (00) (see also Clause 23: Sequential recording).

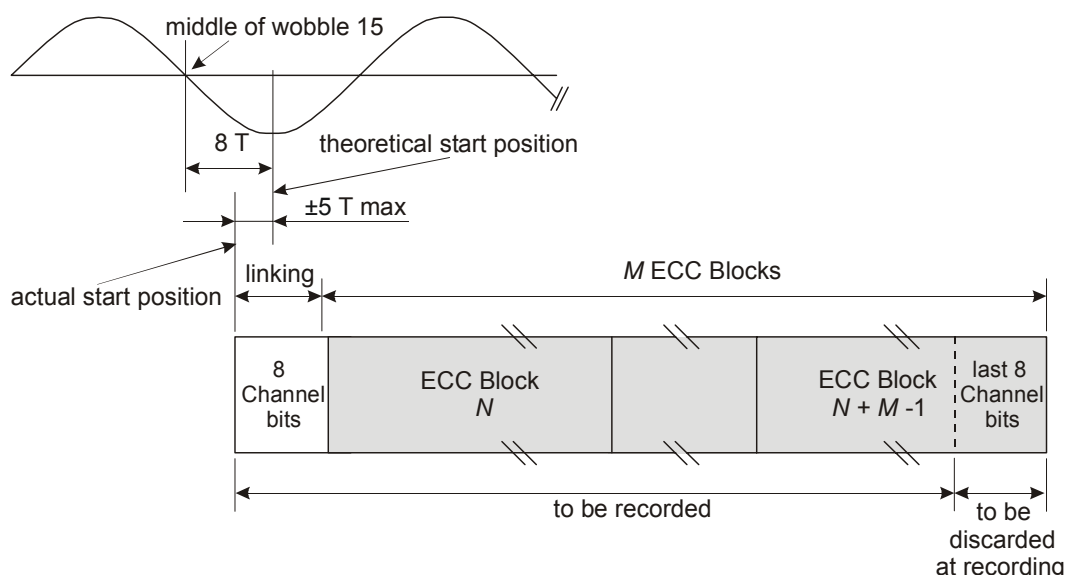

Figure 17 - Recording Unit

13.7.1 Recording Unit position

Each ECC Block, consisting of 16 Physical Sectors, shall correspond to 4 ADIP words (see 14.4.1.1). RUNs shall be mapped onto the structure of tracks (see 14.4), such that the Physical Sector Numbers (PSN), of which the 2 least significant bits have been discarded, correspond to the local Physical Address in ADIP (PAA). In mathematical form: $PSN = 4 \times PAA + i$, where $i = 0, 1, 2, \text{ or } 3$ (for example: Physical Sector Numbers (030000) to (030003) correspond to Physical Address (00C000)).

The reference for the theoretical start positions is wobble 15 following the ADIP word sync unit of the ADIP words of which the 2 least significant address bits are 00 (see 14.4.1.1 and Figure 21). The theoretical start position is 8 Channel bits after the nominal position of the zero crossing in the middle of the above mentioned wobble 15 of the wobble signal from Read channel 2.

The start of each recording shall be within ± 5 Channel bits of the theoretical start position. During writing the Channel bit clock shall be phase locked to the wobble frequency.

13.8 d.c. component suppression control

To ensure a reliable radial tracking and a reliable detection of the HF signals, the low frequency content of the stream of Channel bit patterns should be kept as low as possible. In order to achieve this, the Digital Sum Value (DSV, see 4.3) shall be kept as close to zero as possible. At the beginning of the modulation, the DSV shall be set to 0.

The different ways of diminishing the current value of the DSV are as follows:

- a) Choice of SYNC Codes between Primary or Secondary SYNC Codes.
- b) For the 8-bit bytes in the range 0 to 87, the Substitution table offers an alternative 16-bit Code Word for all States.
- c) For the 8-bit bytes in the range 88 to 255, when the prescribed State is 1 or 4, then the 16-bit Code Word can be chosen either from State 1 or from State 4, so as to ensure that the RLL requirement is met.

In order to use these possibilities, two data streams, Stream 1 and Stream 2, are generated. Stream 1 shall start with the Primary SYNC Code and Stream 2 with the Secondary SYNC Code of the same category of SYNC Codes. As both streams are modulated individually, they generate a different DSV because of the difference between the bit patterns of the Primary and Secondary SYNC Codes.

In the cases b) and c), there are two possibilities to represent a 8-bit byte. The DSV of each stream is computed up to the 8-bit byte preceding the 8-bit byte for which there is this choice. The stream with the lowest $|DSV|$ is selected and duplicated to the other stream. Then, one of the representations of the next 8-bit byte is entered into Stream 1 and the other into Stream 2. This operation is repeated each time case b) or c) occurs.

Whilst case b) always occurs at the same pattern position in both streams, case c) may occur in one of the streams and not in the other because, for instance, the next State prescribed by the previous 8-bit byte can be 2 or 3 instead of 1 or 4. In that case the following 3-step procedure shall be applied:

- 1) Compare the $|DSV|$ s of both streams.
- 2) If the $|DSV|$ of the stream in which case c) occurs is smaller than that of the other stream, then the stream in which case c) has occurred is chosen and duplicated to the other stream. One of the representations of the next 8-bit byte is entered into this stream and the other into the other stream.
- 3) If the $|DSV|$ of the stream in which case c) has occurred is larger than that of the other stream, then case c) is ignored and the 8-bit byte is represented according to the prescribed State.

In both cases b) and c), if the $|DSV|$ s are equal, the decision to choose Stream 1 or Stream 2 is implementation-defined.

The procedure for case a) shall be as follows:

- 1) At the end of each Sync Frame, whether or not case b) and or case c) have occurred, the accumulated DSVs of both streams are compared. The stream with the lower $|DSV|$ is selected and duplicated to the other stream. Then the next Primary SYNC Code and the Secondary SYNC Code of the proper category are inserted each in one of the streams.

Optionally the procedure for case a) can be extended in the following way:

- 2) If the DSV at the end of the resulting Sync Frame is greater than +63 or smaller than -64, then the SYNC Code at the beginning of the Sync Frame is changed from Primary to Secondary or vice versa. If this yields a smaller $|DSV|$, the change is permanent, if the $|DSV|$ is not smaller, the original SYNC Code is retained.

During the DSV computation, the actual values of the DSV may vary between -1 000 and +1 000, thus it is recommended that the count range for the DSV be at least from -1 024 to +1 023.

14 Track format

14.1 Track shape

The area in the Information Zone (see 10.7) shall contain tracks formed from a single spiral groove. Each track shall form a 360° turn of a continuous spiral. The shape of each track is determined by the requirements in Section 5. Recordings shall be made in the groove.

The tracks in the Information Zone contain a phase modulated sinusoidal deviation from the nominal centrelines, called wobble, which contains addressing information.

The tracks shall be continuous in the Information Zone.

The groove tracks shall start at a radius of 22,0 mm max,
and end at a radius of 58,75 mm min (see also Annex A).

14.2 Track path

The track path shall be a continuous spiral from the inside (beginning of the Lead-in Zone) to the outside (end of the Lead-out Zone) when the disk rotates counter-clockwise as viewed from the optical head.

14.3 Track pitch

The track pitch is the distance measured between the average track centrelines of adjacent tracks, measured in the radial direction. The track pitch shall be $0,74 \mu\text{m} \pm 0,03 \mu\text{m}$. The track pitch averaged over the Information Zone shall be $0,74 \mu\text{m} \pm 0,01 \mu\text{m}$.

14.4 Track layout

The wobble of the tracks is a sinusoidal deviation from the nominal centrelines, with a wavelength of $4,265 6 \mu\text{m} \pm 0,045 0 \mu\text{m}$ (equivalent to 32 Channel bits). The Total Harmonic Distortion (THD) of the oscillator for generating the wobble sine wave shall be $\leq -40 \text{ dB}$.

The wobble is phase modulated by inverting wobble cycles. The information contained in the wobble modulation is called Address-in-Pregroove or ADIP (see 14.4.1.1).

14.4.1 ADIP information

The data to be recorded onto the disk must be aligned with the ADIP information modulated in the wobble. Therefore 93 wobbles shall correspond to 2 Sync Frames. Of each 93 wobbles, 8 wobbles are phase modulated with ADIP information (see Figure 18).

1 wobble equals 32 Channel bits (= 32T)

one ADIP unit = 8 modulated wobbles per 2 Sync Frames

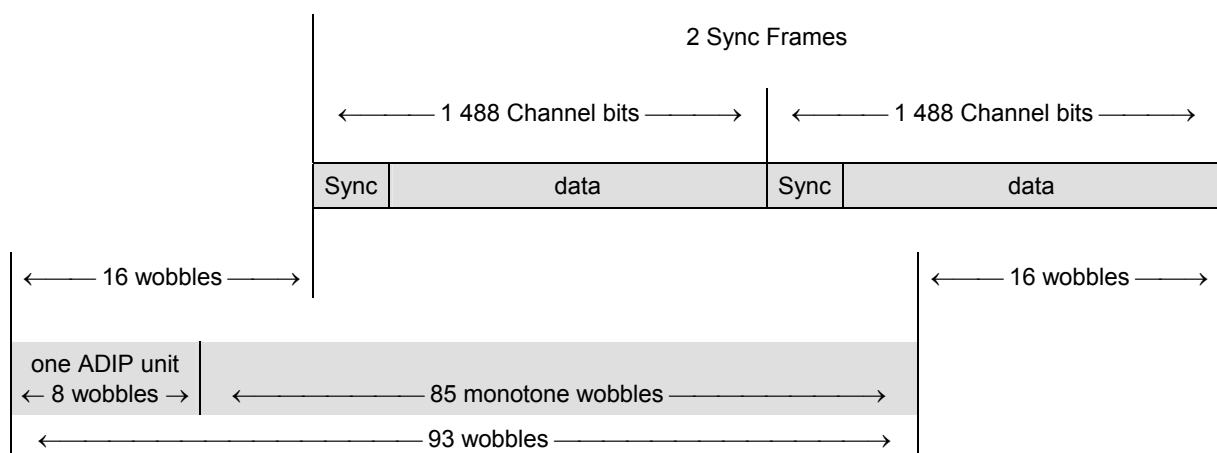

Figure 18 – General ADIP structure

14.4.1.1 ADIP word structure

52 ADIP units are grouped into one ADIP word each.

This means that one ADIP word corresponds to $4 \times 13 \times 2$ Sync Frames \equiv 4 Physical Sectors.

Each ADIP word shall consist of: 1 ADIP sync unit + 51 ADIP data units.

ADIP sync unit = 4 inverted wobbles for word sync + 4 monotone wobbles.

ADIP data unit = 1 inverted wobble for bit sync + 3 monotone wobbles + 4 wobbles representing one data bit. (see 14.4.1.3)

ADIP word structure:

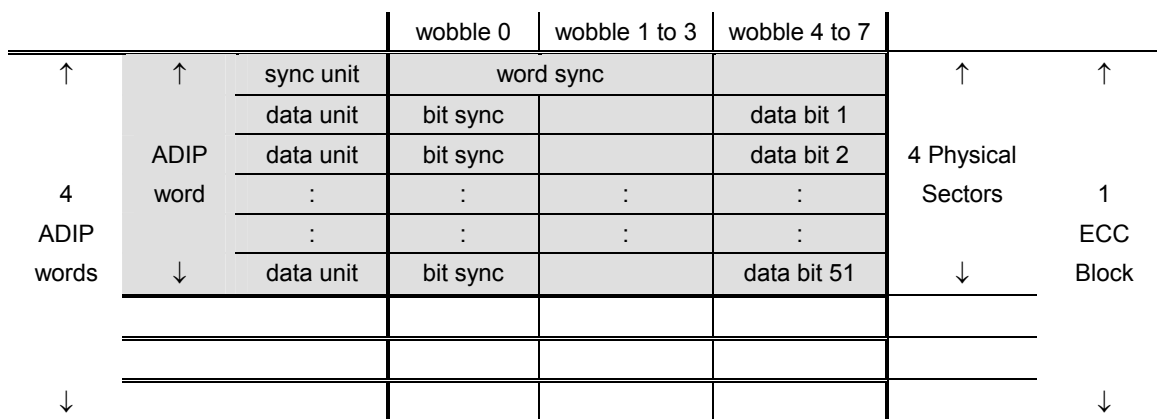

Figure 19 - ADIP word structure

The information contained in the data bits is as follows:

bit 1: this bit is reserved and shall be set to ZERO.

bits 2 to 23: these 22 bits contain a Physical Address. Data bit 2 is the msb and data bit 23 is the lsb. The addresses increase by one for each next ADIP word. The first address in the Information Zone shall be such that Physical Address (00C000) is located at radius $24,0^{+0,0}_{-0,2}$ mm.

Physical Address (098150), which is the first address corresponding to the Lead-out Zone, shall be located at a radius $\leq 58,0$ mm (see also Annex A).

bits 24 to 31: these 8 bits contain auxiliary information about the disk.

In the Data Zone and the Lead-out Zone / Outer Drive Area of the disk the auxiliary bytes shall be set to (00).

In the Lead-in Zone and the Inner Drive Area of the disk the auxiliary bytes shall be used as follows:

Bit 24 to 31 from 256 consecutive ADIP words, shall form one ADIP Aux Frame with 256 bytes of information. The first byte of each ADIP Aux Frame shall be located in an ADIP word with a Physical Address that is a multiple of 256 (Physical Address = (xxxx00)).

The contents of the 256 bytes are defined in Table 3 and 14.4.2.

bits 32 to 51: these 20 bits contain error correction parities for the ADIP information (see 14.4.1.2).

14.4.1.2 ADIP error correction

For the ADIP error correction the ADIP data bits are grouped into 4-bit nibbles. The mapping of the data bits into the nibble array is defined in Figure 20. Bit 0 is a dummy bit, which shall be considered as set to ZERO for the error corrector.

nibble N ₀	bit 0	bit 1	bit 2	bit 3	↑ 6 nibbles ADIP address ↓
nibble N ₁	bit 4	bit 5	:	:	
:	:	:	:	:	
:	bit 20	:	:	bit 23	↑ 2 ↓ nibbles AUX data
:	bit 24				
nibble N ₇	bit 28		:	bit 31	↑ 5 nibbles based R-S ↓ ECC
nibble N ₈	bit 32	:	:	:	
:	:	:	:	:	
:	:	:	:	:	
nibble N ₁₂	bit 48	bit 49	bit 50	bit 51	

Figure 20 - ADIP error correction structure

A nibble-based RS(13,8,6) code is constructed, of which the 5 parity nibbles N₈ to N₁₂, are defined by the remainder polynomial R(x):

$$R(x) = \sum_{i=8}^{12} N_i x^{12-i} = I(x) x^5 \text{ mod } G_{PA}(x)$$

where

$$I(x) = \sum_{i=0}^7 N_i x^{7-i} \quad \text{and} \quad G_{PA}(x) = \prod_{k=0}^4 (x + \alpha^k)$$

α is the primitive root 0010 of the primitive polynomial $P(x) = x^4 + x + 1$

All bits of the 5 parity nibbles N₈ to N₁₂ shall be inverted before recording.

14.4.1.3 ADIP modulation rules

The ADIP units are modulated by inverting some of the 8 wobble cycles:

- PW is a positive wobble, which shall start moving towards the inside of the disk.
- NW is a negative wobble, which shall start moving towards the outside of the disk.
- all monotone wobbles shall be PWs.

Modulation of the ADIP word sync:

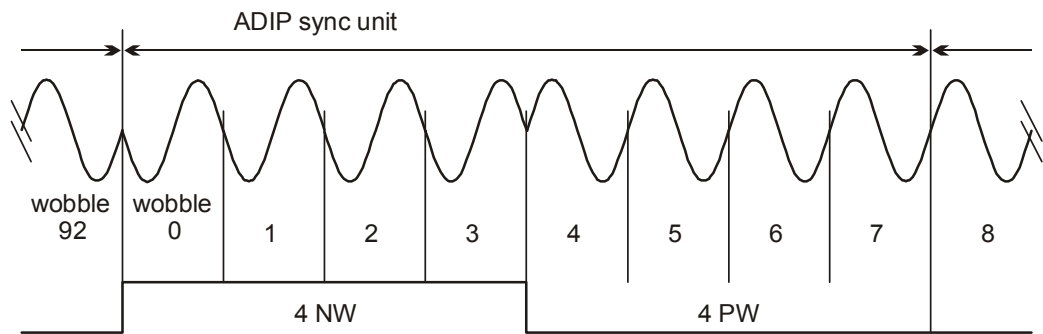

Modulation of an ADIP ZERO bit:

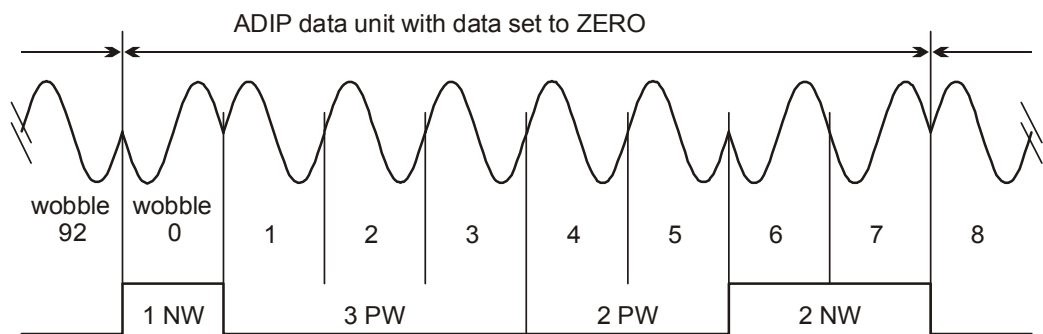

Modulation of an ADIP ONE bit:

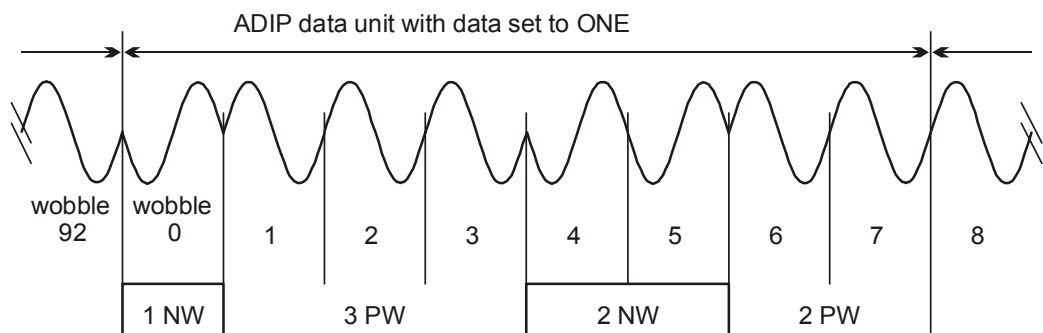

Figure 21 - ADIP modulation rules

Table 3 - Physical format information

Byte number	Content	Number of bytes
0	Disk Category and Version Number	1
1	Disk size	1
2	Disk structure	1
3	Recording density	1
4 to 15	Data Zone allocation	12
16	Set to (00)	1
17	Disk Application Code	1
18	Extended Information indicators	1
19 to 26	Disk Manufacturer ID	8
27 to 29	Media type ID	3
30	Product revision number	1
31	number of Physical format information bytes in use in ADIP up to byte 63	1
32	Primary recording velocity for the basic write strategy	1
33	Upper recording velocity for the basic write strategy	1
34	Wavelength λ_{IND}	1
35	normalized Write power dependency on Wavelength $(dP/d\lambda)/(P_{IND}/\lambda_{IND})$	1
36	Maximum read power at Primary velocity	1
37	P_{IND} at Primary velocity	1
38	β_{target} at Primary velocity	1
39	Maximum read power at Upper velocity	1
40	P_{IND} at Upper velocity	1
41	β_{target} at Upper velocity	1
42	$T_{top} (\geq 4)$ first pulse duration for $cm^* \geq 4$ at Primary velocity	1
43	$T_{top} (=3)$ first pulse duration for $cm^* = 3$ at Primary velocity	1
44	T_{mp} multi pulse duration at Primary velocity	1
45	T_{lp} last pulse duration at Primary velocity	1
46	$dT_{top} (\geq 4)$ first pulse lead time for $cm^* \geq 4$ at Primary velocity	1
47	$dT_{top} (=3)$ first pulse lead time for $cm^* = 3$ at Primary velocity	1
48	dT_{le} first pulse leading edge shift for $ps^* = 3$ at Primary velocity	1
49	$T_{top} (\geq 4)$ first pulse duration for $cm^* \geq 4$ at Upper velocity	1
50	$T_{top} (=3)$ first pulse duration for $cm^* = 3$ at Upper velocity	1
51	T_{mp} multi pulse duration at Upper velocity	1
52	T_{lp} last pulse duration at Upper velocity	1
53	$dT_{top} (\geq 4)$ first pulse lead time for $cm^* \geq 4$ at Upper velocity	1
54	$dT_{top} (=3)$ first pulse lead time for $cm^* = 3$ at Upper velocity	1
55	dT_{le} first pulse leading edge shift for $ps^* = 3$ at Upper velocity	1
56 to 63	Reserved - All (00)	8
64 to 95	Extended Information block 0	32
96 to 127	Extended Information block 1	32
128 to 159	Extended Information block 2	32
160 to 191	Extended Information block 3	32

* cm = current mark, ps = previous space (see also Annex F)

Byte number	Content	Number of bytes
192 to 223	Extended Information block 4	32
224 to 247	Extended Information block 5	24
248 to 255	Reserved for use in the Control Data Zone – All (00)	8

14.4.2 Physical format information in ADIP

This information shall comprise the 256 bytes shown in Table 3. It contains disk information and values for the write strategy parameters to be used with the Optimum Power Control (OPC) algorithm to determine optimum laser power levels for writing (see Annex F and Annex H). The information is copied to the Control Data Zone (see 18.8.1) during finalization of the Lead-in Zone of the disk.

This version of this document specifies several types of disks, with different recording velocity ranges. The specific write parameters for each recording velocity range shall be specified in separate blocks (EI blocks, see 14.4.2.3). The following types of disks (characterized by the so-called X-speed) have now been defined and their ADIP shall contain the EI Blocks as indicated in Table 4.

Table 4 - Types of disks

type of disk	basic write strategy bytes 32 to 63 (1x & 2,4x speed)	4x+ write strategy EI block format 1 (4x speed)	remarks
"2,4x"	+	–	this disk shall be suited for recording speeds of 3,49 & 8,44 m/s only
"4x"	+	+	this disk shall be suited for recording speeds of 3,49 & 8,44 m/s and 13,95 m/s

+ shall be present – shall not be used

14.4.2.1 General information - Bytes 0 to 31

Byte 0 – Disk Category and Version Number

Bits b_7 to b_4 shall specify the Disk Category, they shall be set to 1010, indicating a +R disk.

Bits b_3 to b_0 shall specify the Version Number, they shall be set to 0001 indicating this Ecma Standard. This Version Number identifies amongst others the definitions of the data in bytes 32 to 63. Drives not acquainted with the specific Version Number of a disk should not try to record on that disk using the information in bytes 32 to 63, which bytes contain the basic write strategy parameters (see Annex N).

Byte 1 – Disk size and maximum transfer rate

Bits b_7 to b_4 shall specify the disk size, they shall be set to 0000, indicating a 120 mm disk (see also Annex A)

Bits b_3 to b_0 shall specify the maximum read transfer rate, they shall be set to 1111 indicating no maximum read transfer rate is specified

Byte 2 – Disk structure

Bits b_7 to b_4 shall be set to 0000

Bits b_3 to b_0 shall specify the type of the recording layer(s):
they shall be set to 0010, indicating a write-once recording layer.

Byte 3 – Recording density

Bits b_7 to b_4 shall specify the average Channel bit length in the Information Zone,
they shall be set to 0000, indicating 0,133 μm

Bits b_3 to b_0 shall specify the average track pitch,
they shall be set to 0000, indicating an average track pitch of 0,74 μm

Bytes 4 to 15 – Data Zone allocation

Byte 4 shall be set to (00).

Bytes 5 to 7 shall be set to (030000) to specify PSN 196 608 of the first Physical Sector of the Data Zone

Byte 8 shall be set to (00).

Bytes 9 to 11 shall be set to (26053F) to specify PSN 2 491 711 as the last possible Physical Sector of the Data Zone (see also Annex A).

Bytes 12 to 15 shall be set to (00)

Byte 16 – (00)

This byte shall be set to (00).

Byte 17 – Disk Application Code

This byte can identify disks that are restricted to be used for special applications only. Drives not able to identify the particular application related to a specific Disk Application Code or not able to act according to the rules as defined for this particular application are not allowed to write on a disk with such a code.

(00) identifies a disk for General Purpose use
(no restrictions, all drives are allowed to write on a disk carrying this code),

all other codes are reserved.

Byte 18 – Extended Information indicators

Bits b_7 to b_6 are reserved and shall be set to 00

Bits b_5 to b_0 each of these bits shall indicate the presence of an Extended Information block.

Bit b_i shall be set to 1 if Extended Information block i , consisting of bytes $(64 + i \times 32)$ to $(95 + i \times 32)$, is in use. Else bit b_i shall be set to 0.

Bytes 19 to 26 – Disk Manufacturer ID

These 8 bytes shall identify the manufacturer of the disk. This name shall be represented by characters from the G0 set + SPACE according to ECMA-43. Trailing bytes not used shall be set to (00).

If the Disk Manufacturer ID is not used, these 8 bytes shall be set to (00)

Bytes 27 to 29 – Media type ID

Disk manufacturers can have different types of media, which shall be specified by these 3 bytes. The specific type of disk is denoted in this field by characters from the G0 set + SPACE according to ECMA-43. Trailing bytes not used shall be set to (00).

If the Media type ID is not used these 3 bytes shall be set to (00)

NOTE

Disks with different characteristics shall be identified by different and unique combinations of Disk Manufacturer ID / Media type ID. Therefore the contents of bytes 19 to 29 shall be approved by the licensors of the +R system.

Byte 30 – Product revision number

This byte shall identify the product revision number in binary notation. All disks with the same Disk Manufacturer ID and the same Media type ID, regardless of Product revision numbers, must have the same recording properties (only minor differences are allowed: Product revision numbers shall be irrelevant for recorders). The content of this byte can be chosen freely by the disk manufacturer.

If not used this byte shall be set to (00)

Byte 31 – number of Physical format information bytes in use in ADIP up to byte 63

This byte forms one 8-bit binary number indicating the number of bytes actually in use for the basic Physical format information (in bytes 0 to 63). It shall be set to (38) indicating that only the first 56 bytes of the Physical format information are used.

14.4.2.2 Basic write strategy parameters - Bytes 32 to 63

Byte 32 – Primary recording velocity for the basic write strategy

This byte indicates the lowest recording velocity of the disk for the parameters as defined in bytes 34 to 63 in this Physical format information. This recording velocity is equal to the Reference velocity and shall be specified as a number n such that

$$n = 10 \times v_{\text{Primary,basic}} \quad (n \text{ rounded off to an integral value})$$

It shall be

set to (23) indicating a Primary writing speed of 3,49 m/s.

Byte 33 – Upper recording velocity for the basic write strategy

This byte indicates the highest recording velocity of the disk for the parameters as defined in bytes 34 to 63 in this Physical format information. This recording velocity shall be specified as a number n such that

$$n = 10 \times v_{\text{Upper,basic}} \quad (n \text{ rounded off to an integral value})$$

It shall be

set to (54) indicating a Upper writing speed of 8,44 m/s.

Byte 34 – Wavelength λ_{IND}

This byte shall specify the laser wavelength in nanometers at which the optimum write parameters in the following bytes are specified, as a number n such that

$$n = \text{Wavelength} - 600$$

For this version of the +R system, n shall be equal to (37) indicating that λ_{IND} is 655 nanometers.

Byte 35 – Normalized Write power dependency on Wavelength

This byte shall specify the average write power dependency on the wavelength normalized by the ratio of P_{IND} and λ_{IND} (see 29.3.3 and Annex J), as a number n such that

$$n = (dP/d\lambda)/(P_{\text{IND}}/\lambda_{\text{IND}})$$

Byte 36 – Maximum read power, P_r at Primary velocity

This byte shall specify the maximum read power P_r in milliwatts at Primary velocity as a number n such that

$$n = 20 \times (P_r - 0,7)$$

Byte 37 – P_{IND} at Primary velocity

P_{IND} is the starting value for the determination of P_{wo} used in the OPC algorithm, see Annex H and Annex J.

This byte shall specify the indicative value P_{IND} of P_{wo} in milliwatts at Primary velocity and λ_{IND} as a number n such that

$$n = 20 \times (P_{IND} - 5)$$

Byte 38 – β_{target} at Primary velocity

This byte shall specify the target value for β , β_{target} at Primary velocity used in the OPC algorithm (see Annex H) as a number n such that

$$n = 100 \times (\beta_{target} + 1)$$

Byte 39 – Maximum read power, P_r at Upper velocity

This byte shall specify the maximum read power P_r in milliwatts at Upper velocity as a number n such that

$$n = 20 \times (P_r - 0,7)$$

Byte 40 – P_{IND} at Upper velocity

P_{IND} is the starting value for the determination of P_{wo} used in the OPC algorithm, see Annex H and Annex J.

This byte shall specify the indicative value P_{IND} of P_{wo} in milliwatts at Upper velocity and λ_{IND} as a number n such that

$$n = 20 \times (P_{IND} - 5)$$

Byte 41 – β_{target} at Upper velocity

This byte shall specify the target value for β , β_{target} at Upper velocity used in the OPC algorithm (see Annex H) as a number n such that

$$n = 100 \times (\beta_{target} + 1)$$

Byte 42 – $T_{top} (\geq 4)$ first pulse duration for current mark ≥ 4 at Primary velocity

This byte shall specify the duration of the first pulse of the multi pulse train when the current mark is a 4T or greater mark for recording at Primary velocity (see Annex F.1). The value is expressed in fractions of the Channel bit clock period as a number n such that

$$n = 16 \times \frac{T_{top}}{T_W} \quad \text{and} \quad 4 \leq n \leq 40$$

Byte 43 – $T_{top} (=3)$ first pulse duration for current mark =3 at Primary velocity

This byte shall specify the duration of the first pulse of the multi pulse train when the current mark is a 3T mark for recording at Primary velocity (see Annex F.1). The value is expressed in fractions of the Channel bit clock period as a number n such that

$$n = 16 \times \frac{T_{top}}{T_W} \quad \text{and} \quad 4 \leq n \leq 40$$

Byte 44 – T_{mp} multi pulse duration at Primary velocity

This byte shall specify the duration of the 2nd pulse through the 2nd to last pulse of the multi pulse train for recording at Primary velocity (see Annex F.1). The value is expressed in fractions of the Channel bit clock period as a number n such that

$$n = 16 \times \frac{T_{mp}}{T_W} \quad \text{and} \quad 4 \leq n \leq 14$$

Byte 45 – T_{lp} last pulse duration at Primary velocity

This byte shall specify the duration of the last pulse of the multi pulse train when the current mark is a 4T or greater mark for recording at Primary velocity (see Annex F.1). The value is expressed in fractions of the Channel bit clock period as a number n such that

$$n = 16 \times \frac{T_{lp}}{T_W} \quad \text{and} \quad 4 \leq n \leq 24$$

Byte 46 – $dT_{top} (\geq 4)$ first pulse lead time for current mark ≥ 4 at Primary velocity

When the current mark is a 4T or greater mark, this byte shall specify the lead time of the first pulse of the multi pulse train relative to the trailing edge of the second Channel bit of the data pulse, for recording at Primary velocity (see Annex F.1). The value is expressed in fractions of the Channel bit clock period as a number n such that

$$n = 16 \times \frac{dT_{top}}{T_W} \quad \text{and} \quad 0 \leq n \leq 24$$

Byte 47 – $dT_{top} (=3)$ first pulse lead time for current mark =3 at Primary velocity

When the current mark is a 3T mark, this byte shall specify the lead time of the first pulse of the multi pulse train relative to the trailing edge of the second Channel bit of the data pulse, for recording at Primary velocity (see Annex F.1). The value is expressed in fractions of the Channel bit clock period as a number n such that

$$n = 16 \times \frac{dT_{top}}{T_W} \quad \text{and} \quad 0 \leq n \leq 24$$

Byte 48 – dT_{le} first pulse leading edge shift for previous space =3 at Primary velocity

This byte shall specify the leading edge correction for the 1st pulse of the multi pulse train when the previous space was a 3T space for recording at Primary velocity (see Annex F.1). The value is expressed in fractions of the Channel bit clock period as a number n such that

$$n = 16 \times \frac{dT_{le}}{T_W} \quad \text{and} \quad 0 \leq n \leq 4$$

Byte 49 – $T_{top} (\geq 4)$ first pulse duration for current mark ≥ 4 at Upper velocity

This byte shall specify the duration of the first pulse of the multi pulse train when the current mark is a 4T or greater mark for recording at Upper velocity (see Annex F.1). The value is expressed in fractions of the Channel bit clock period as a number n such that

$$n = 16 \times \frac{T_{top}}{T_W} \quad \text{and} \quad 4 \leq n \leq 40$$

Byte 50 – $T_{top} (3)$ first pulse duration for current mark =3 at Upper velocity

This byte shall specify the duration of the first pulse of the multi pulse train when the current mark is a 3T mark for recording at Upper velocity (see Annex F.1). The value is expressed in fractions of the Channel bit clock period as a number n such that

$$n = 16 \times \frac{T_{top}}{T_W} \quad \text{and} \quad 4 \leq n \leq 40$$

Byte 51 – T_{mp} multi pulse duration at Upper velocity

This byte shall specify the duration of the 2nd pulse through the 2nd to last pulse of the multi pulse train for recording at Upper velocity (see Annex F.1). The value is expressed in fractions of the Channel bit clock period as a number n such that

$$n = 16 \times \frac{T_{mp}}{T_W} \quad \text{and} \quad 4 \leq n \leq 14$$

Byte 52 – T_{lp} last pulse duration at Upper velocity

This byte shall specify the duration of the last pulse of the multi pulse train when the current mark is a 4T or greater mark for recording at Upper velocity (see Annex F.1). The value is expressed in fractions of the Channel bit clock period as a number n such that

$$n = 16 \times \frac{T_{lp}}{T_W} \quad \text{and} \quad 4 \leq n \leq 24$$

Byte 53 – $dT_{top} (\geq 4)$ first pulse lead time for current mark ≥ 4 at Upper velocity

When the current mark is a 4T or greater mark, this byte shall specify the lead time of the first pulse of the multi pulse train relative to the trailing edge of the second Channel bit of the data pulse, for recording at Upper velocity (see Annex F.1). The value is expressed in fractions of the Channel bit clock period as a number n such that

$$n = 16 \times \frac{dT_{top}}{T_W} \quad \text{and} \quad 0 \leq n \leq 24$$

Byte 54 – $dT_{top} (=3)$ first pulse lead time for current mark =3 at Upper velocity

When the current mark is a 3T mark, this byte shall specify the lead time of the first pulse of the multi pulse train relative to the trailing edge of the second Channel bit of the data pulse, for recording at Upper velocity (see Annex F.1). The value is expressed in fractions of the Channel bit clock period as a number n such that

$$n = 16 \times \frac{dT_{top}}{T_W} \quad \text{and} \quad 0 \leq n \leq 24$$

Byte 55 – dT_{le} first pulse leading edge shift for previous space =3 at Upper velocity

This byte shall specify the leading edge correction for the 1st pulse of the multi pulse train when the previous space was a 3T space for recording at Upper velocity (see Annex F.1). The value is expressed in fractions of the Channel bit clock period as a number n such that

$$n = 16 \times \frac{dT_{le}}{T_W} \quad \text{and} \quad 0 \leq n \leq 4$$

Bytes 56 to 63 – Reserved - All (00)

These bytes shall be set to all (00).

14.4.2.3 Extended Information blocks - Bytes (64 + $i \times 32$) to (95 + $i \times 32$)

($i = 0$ to 5)

Extended Information (EI) blocks are meant to facilitate future extensions. Each such block consists of 32 bytes. These bytes can hold for instance parameters for alternative write strategies or other advanced parameters. The presence of an Extended Information block shall be indicated by the appropriate bit in byte 18. If an Extended Information block is not used, all 32 bytes shall be set to (00).

Byte (64 + $i \times 32$) Extended Information block i format number

indicates the format number which identifies the definitions of the data in bytes (65 + $i \times 32$) to (95 + $i \times 32$).

A disk can have several Extended Information blocks. The contents of blocks with different format numbers have to be interpreted each according to their respective definitions. The contents of blocks with the same format number are interpreted in the same way; the parameters specified in these blocks can have different values. Drives not acquainted with the specific format number in block i , should not use the parameters in this Extended Information block (see Annex N).

If the format number is set to 255, the related Extended Information block is not an independent block but a continuation of the preceding Extended Information block (to be used if 32 bytes are not sufficient for a set of parameters).

NOTE

The contents of an EI block are identified by the format number of the block only. The position of the EI block in the ADIP Aux Frame is irrelevant for this, so an EI block with format number n could be allocated at any position i . Therefore drives should always check the format numbers in the EI blocks to be sure that the write strategies are correctly interpreted.

Bytes (65 + $i \times 32$) to (95 + $i \times 32$)

Each parameter set defined for these bytes shall be identified by a unique format number.

Bytes 248 to 255 – Reserved for use in the Control Data Zone - All (00)

These bytes can not be copied to the Control Data Zone and shall therefore not be used and be set to (00).

14.4.2.3.1 Extended information for the “4x+” write strategy

This Extended Information block specifies the parameters for a write strategy usable at speeds of 4 times the basic DVD speed ($4 \times 3,49$ m/s) or higher. The write strategy used at these speeds is a so-called “Blocked” write strategy as defined in Annex F.2.

If the disk can not be recorded under these “4x+” conditions, this EI block shall not be used (all bytes set to (00)).

Byte 18 – Extended Information indicators

This byte shall be set to xxxx xxx1 indicating Extended Information block 0 is in use.

Table 5 - Extended Information block 0

Byte number	Content	Number of bytes
64	Format number	1
65	Reserved - set to (00)	1
66	Primary recording velocity for the parameter set in this EI block	1
67	Upper recording velocity for the parameter set in this EI block	1
68	Maximum read power at Primary velocity	1
69	P_{IND} at Primary velocity	1
70	β_{target} at Primary velocity	1
71	$dP_w (=3)$ power enhancement for $cm =3$ at Primary velocity	1
72	$dP_w (=4)$ power enhancement for $cm =4$ at Primary velocity	1
73	$T_{top} (\geq 4)$ first part of write pulse for $cm \geq 4$ at Primary velocity (= $dT_{top} (\geq 4) + T_W$)	1
74	$T_{top} (=3)$ write pulse duration for $cm =3$ at Primary velocity	1
75	T_{mp} at Primary velocity (= T_W)	1
76	T_{lp} last part of write pulse for $cm \geq 4$ at Primary velocity	1
77	$dT_{top} (\geq 4)$ write pulse lead time for $cm \geq 4$ at Primary velocity	1
78	$dT_{top} (=3)$ write pulse lead time for $cm =3$ at Primary velocity	1
79	dT_{le} write pulse leading edge correction for $ps =3$ at Primary velocity	1
80	Reserved - set to (00)	1

Byte number	Content	Number of bytes
81	Reserved - set to (00)	1
82	Maximum read power at Upper velocity	1
83	P _{IND} at Upper velocity	1
84	β _{target} at Upper velocity	1
85	dP _w (=3) power enhancement for cm =3 at Upper velocity	1
86	dP _w (=4) power enhancement for cm =4 at Upper velocity	1
87	T _{top} (≥4) first part of write pulse for cm ≥4 at Upper velocity (= dT _{top} (≥4) + T _W)	1
88	T _{top} (=3) write pulse duration for cm =3 at Upper velocity	1
89	T _{mp} at Upper velocity (= T _W)	1
90	T _{lp} last part of write pulse for cm ≥4 at Upper velocity	1
91	dT _{top} (≥4) write pulse lead time for cm ≥4 at Upper velocity	1
92	dT _{top} (=3) write pulse lead time for cm =3 at Upper velocity	1
93	dT _{le} write pulse leading edge correction for ps =3 at Upper velocity	1
94	Reserved - set to (00)	1
95	Reserved - set to (00)	1

Byte 64 – Extended Information block 0 format number

This byte shall be set to 0000 0001 indicating format 1, for which bytes 65 to 95 have the following meaning:

Byte 65 – Reserved

This byte is reserved and shall be set to (00)

Byte 66 – Primary recording velocity for the parameter set in this EI block

This byte indicates the lowest recording velocity of the disk for the parameters as defined in this EI block. This recording velocity shall be specified as a number n such that

$$n = 4 \times v_{\text{Primary,EI } 0} \text{ (} n \text{ rounded off to an integral value)}$$

It shall be

set to (38) indicating a Primary writing speed of 14 m/s.

Byte 67 – Upper recording velocity for the parameter set in this EI block

This byte indicates the highest recording velocity of the disk for the parameters as defined in this EI block. This recording velocity shall be specified as a number n such that

$$n = 4 \times v_{\text{Upper,EI } 0} \text{ (} n \text{ rounded off to an integral value)}$$

It shall be

set to (38) indicating an Upper writing speed of 14 m/s. (In future when higher recording speeds which are compatible with this write strategy become possible, higher values can be allowed.)

Byte 68 – Maximum read power, P_r at Primary velocity

This byte shall specify the maximum read power P_r in milliwatts at Primary velocity as a number n such that

$$n = 20 \times (P_r - 0,7)$$

Byte 69 – P_{IND} at Primary velocity

P_{IND} is the starting value for the determination of P_{w0} used in the OPC algorithm, see Annex H and Annex J.

This byte shall specify the indicative value P_{IND} of P_{wo} in milliwatts at Primary velocity and λ_{IND} as a number n such that

$$n = 5 \times (P_{IND} - 5)$$

Byte 70 – β_{target} at Primary velocity

This byte shall specify the target value for β , β_{target} at Primary velocity used in the OPC algorithm (see Annex H) as a number n such that

$$n = 100 \times (\beta_{target} + 1)$$

Byte 71 – dP_w (=3) power enhancement for current mark =3 at Primary velocity

This byte shall specify the additional power for writing the 3T marks (see Annex F.2) at Primary velocity as a number n such that

$$n = 200 \times dP_w / P_{wo} \quad \text{and} \quad 0 \leq n \leq 100$$

Byte 72 – dP_w (=4) power enhancement for current mark =4 at Primary velocity

This byte shall specify the additional power for writing the 4T marks (see Annex F.2) at Primary velocity as a number n such that

$$n = 200 \times dP_w / P_{wo} \quad \text{and} \quad 0 \leq n \leq 100$$

Byte 73 – T_{top} (≥ 4) first part of write pulse for current mark ≥ 4 at Primary velocity

This byte shall specify the duration of the first part of the write pulse when the current mark is a 4T or greater mark for recording at Primary velocity (see Annex F.2). The value is expressed in fractions of the Channel bit clock period as a number n such that

$$n = 16 \times \frac{T_{top}}{T_W} \quad \text{and} \quad n = \text{value of byte 77} + 16$$

Byte 74 – T_{top} (=3) write pulse duration for current mark =3 at Primary velocity

This byte shall specify the duration of the write pulse when the current mark is a 3T mark for recording at Primary velocity (see Annex F.2). The value is expressed in fractions of the Channel bit clock period as a number n such that

$$n = 16 \times \frac{T_{top}}{T_W} \quad \text{and} \quad 4 \leq n \leq 48$$

Byte 75 – T_{mp} at Primary velocity

This byte has been added for consistency with the basic description of the write strategy (see Annex F). The value is expressed in fractions of the Channel bit clock period as a number n such that

$$n = 16 \times \frac{T_{mp}}{T_W} \quad \text{and} \quad n = 16$$

Byte 76 – T_{lp} last part of write pulse at Primary velocity

This byte shall specify the duration of the last part of the write pulse when the current mark is a 4T or greater mark for recording at Primary velocity (see Annex F.2). The value is expressed in fractions of the Channel bit clock period as a number n such that

$$n = 16 \times \frac{T_{lp}}{T_W} \quad \text{and} \quad 0 \leq n \leq 16$$

Byte 77 – $dT_{top} (\geq 4)$ write pulse lead time for current mark ≥ 4 at Primary velocity

When the current mark is a 4T or greater mark, this byte shall specify the lead time of the write pulse relative to the trailing edge of the second Channel bit of the data pulse, for recording at Primary velocity (see Annex F.2). The value is expressed in fractions of the Channel bit clock period as a number n such that

$$n = 16 \times \frac{dT_{top}}{T_W} \quad \text{and} \quad 0 \leq n \leq 32$$

Byte 78 – $dT_{top} (=3)$ write pulse lead time for current mark =3 at Primary velocity

When the current mark is a 3T mark, this byte shall specify the lead time of the write pulse relative to the trailing edge of the second Channel bit of the data pulse, for recording at Primary velocity (see Annex F.2). The value is expressed in fractions of the Channel bit clock period as a number n such that

$$n = 16 \times \frac{dT_{top}}{T_W} \quad \text{and} \quad 0 \leq n \leq 32$$

Byte 79 – dT_{le} write pulse leading edge correction for previous space =3 at Primary velocity

This byte shall specify the leading edge correction for the write pulse when the previous space was a 3T space for recording at Primary velocity (see Annex F.2). The value is expressed in fractions of the Channel bit clock period as a number n such that

$$n = 16 \times \frac{dT_{le}}{T_W} \quad \text{and} \quad 0 \leq n \leq 4$$

Bytes 80 to 81 – Reserved - All (00)

These bytes shall be set to all (00).

Byte 82 – Maximum read power, P_r at Upper velocity

This byte shall specify the maximum read power P_r in milliwatts at Upper velocity as a number n such that

$$n = 20 \times (P_r - 0,7)$$

Byte 83 – P_{IND} at Upper velocity

P_{IND} is the starting value for the determination of P_{wo} used in the OPC algorithm, see Annex H and Annex J.

This byte shall specify the indicative value P_{IND} of P_{wo} in milliwatts at Upper velocity and λ_{IND} as a number n such that

$$n = 5 \times (P_{IND} - 5)$$

Byte 84 – β_{target} at Upper velocity

This byte shall specify the target value for β , β_{target} at Upper velocity used in the OPC algorithm (see Annex H) as a number n such that

$$n = 100 \times (\beta_{target} + 1)$$

Byte 85 – $dP_w (=3)$ power enhancement for current mark =3 at Upper velocity

This byte shall specify the additional power for writing the 3T marks (see Annex F.2) at Upper velocity as a number n such that

$$n = 200 \times dP_w / P_{wo} \quad \text{and} \quad 0 \leq n \leq 100$$

Byte 86 – dPw (=4) power enhancement for current mark =4 at Upper velocity

This byte shall specify the additional power for writing the 4T marks (see Annex F.2) at Upper velocity as a number n such that

$$n = 200 \times dPw / Pwo \quad \text{and} \quad 0 \leq n \leq 100$$

Byte 87 – T_{top} (≥4) first part of write pulse for current mark ≥4 at Upper velocity

This byte shall specify the duration of the first part of the write pulse when the current mark is a 4T or greater mark for recording at Upper velocity (see Annex F.2). The value is expressed in fractions of the Channel bit clock period as a number n such that

$$n = 16 \times \frac{T_{top}}{T_W} \quad \text{and} \quad n = \text{value of byte 91} + 16$$

Byte 88 – T_{top} (=3) write pulse duration for current mark =3 at Upper velocity

This byte shall specify the duration of the write pulse when the current mark is a 3T mark for recording at Upper velocity (see Annex F.2). The value is expressed in fractions of the Channel bit clock period as a number n such that

$$n = 16 \times \frac{T_{top}}{T_W} \quad \text{and} \quad 4 \leq n \leq 48$$

Byte 89 – T_{mp} at Upper velocity

This byte has been added for consistency with the basic description of the write strategy (see Annex F). The value is expressed in fractions of the Channel bit clock period as a number n such that

$$n = 16 \times \frac{T_{mp}}{T_W} \quad \text{and} \quad n = 16$$

Byte 90 – T_{lp} last part of write pulse at Upper velocity

This byte shall specify the duration of the last part of the write pulse when the current mark is a 4T or greater mark for recording at Upper velocity (see Annex F.2). The value is expressed in fractions of the Channel bit clock period as a number n such that

$$n = 16 \times \frac{T_{lp}}{T_W} \quad \text{and} \quad 0 \leq n \leq 16$$

Byte 91 – dT_{top} (≥4) write pulse lead time for current mark ≥4 at Upper velocity

When the current mark is a 4T or greater mark, this byte shall specify the lead time of the write pulse relative to the trailing edge of the second Channel bit of the data pulse, for recording at Upper velocity (see Annex F.2). The value is expressed in fractions of the Channel bit clock period as a number n such that

$$n = 16 \times \frac{dT_{top}}{T_W} \quad \text{and} \quad 0 \leq n \leq 32$$

Byte 92 – dT_{top} (=3) write pulse lead time for current mark =3 at Upper velocity

When the current mark is a 3T mark, this byte shall specify the lead time of the write pulse relative to the trailing edge of the second Channel bit of the data pulse, for recording at Upper velocity (see Annex F.2). The value is expressed in fractions of the Channel bit clock period as a number n such that

$$n = 16 \times \frac{dT_{top}}{T_W} \quad \text{and} \quad 0 \leq n \leq 32$$

Byte 93 – dT_{le} write pulse leading edge correction for previous space =3 at Upper velocity

This byte shall specify the leading edge correction for the write pulse when the previous space was a 3T space for recording at Upper velocity (see Annex F.2). The value is expressed in fractions of the Channel bit clock period as a number n such that

$$n = 16 \times \frac{dT_{le}}{T_W} \quad \text{and} \quad 0 \leq n \leq 4$$

Bytes 94 to 95 – Reserved - All (00)

These bytes shall be set to all (00).

Section 4 - Format of the Information Zone

15 General description of the Information Zone

The Information Zone shall contain all information on the disk relevant for data interchange. The Information Zone may contain one or more sessions (see Clause 22). In double-sided disks there is one Information Zone per side. The Data Zones are intended for the recording of User Data.

The Lead-in Zone contains control information. The Lead-out Zone allows for a continuous smooth lead-out and also contains control information.

The Inner and Outer Drive Areas are meant for disk testing.

In the next Clauses 16 to 21 a description is given for a Single-session disk. In such a disk, the Lead-in Zone, the Data Zone and the Lead-out Zone constitute the recordable area in which the information is recorded using a non-reversible effect. The layout of a Multi-session disk is defined in Clause 22.

16 Layout of the Information Zone of a Single-session disk

The Information Zone of single-sided and of each side of double-sided disks shall be sub-divided as shown in Table 6. The radii indicated in Table 6 for some of the Zones are the nominal values of the centre of the first (or last) track of the Zone.

16.1 Physical Sector Numbers (PSNs)

The first Physical Sector of the Data Zone shall have PSN (030000). The PSNs increase by 1 for each next Physical Sector in the whole Information Zone (Figure 22).

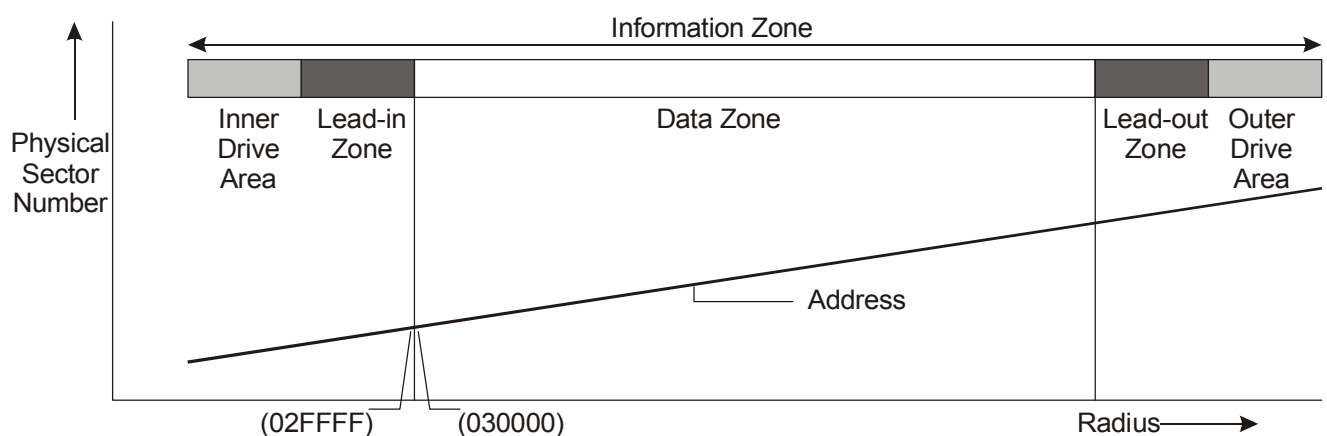

Figure 22 - Physical Sector numbering

NOTE

The Physical Sector Number of the first Physical Sector of the Data Zone is large enough so as to prevent a Physical Sector Number ≤ 0 to occur anywhere on the disk.

Table 6 - Layout of a fully recorded Single-session disk (see also Annex A)

	Description	Nominal radius in mm	PSN of the first Physical Sector	Number of Physical Sectors
<u>Inner Drive Area</u>	Initial Zone	start 22,000 mm	--	blank
	Inner Disk Test Zone	start 22,616 mm	(023080)	16 384
	Count Zone Run-in	start 23,052 mm	(027080)	1 024
	Inner Disk Count Zone	start 23,079 mm	(027480)	4 096
	Inner Disk Administration Zone	start 23,186 mm	(028480)	4 096
	Table of Contents Zone	start 23,293 mm	(029480)	4 096
<u>Lead-in</u>	Guard Zone 1	start 23,400 mm	(02A480)	14 848
	Reserved Zone 1		(02DE80)	4 096
	Reserved Zone 2		(02EE80)	64
	Inner Disk Identification Zone		(02EEC0)	256
	Reserved Zone 3		(02EFC0)	64
	Reference Code Zone	start 23,896 mm	(02F000)	32
	Buffer Zone 1		(02F020)	480
	Control Data Zone		(02F200)	3 072
	Buffer Zone 2		(02FE00)	512
<u>Data</u>	Data Zone	start 24,000 mm	(030000)	2 295 104 max
<u>Lead-out</u>	Buffer Zone 3	start 58,000 mm (at full capacity)	(260540) max	768
	Outer Disk Identification Zone		(260840) max	256
	Guard Zone 2		(260940) max	4 096 min
<u>Outer Drive Area</u>	Outer Disk Administration Zone	start 58,053 mm	(261940)	4 096
	Outer Disk Count Zone	start 58,096 mm	(262940)	4 096
	Outer Disk Test Zone	start 58,139 mm	(263940)	16 384
	Guard Zone 3	start 58,310 mm	(267940)	blank

17 Inner Drive Area

The Inner Drive Area is the innermost zone of the disk which is used by the drive for performing disk tests and OPC algorithms. It shall consist of the parts shown in Figure 23.

The Physical Sector Number of the first and last Physical Sector of each part is indicated in Figure 23 in hexadecimal and decimal notation and the number of Physical Sectors in each part are indicated in decimal notation.

Unused ECC Blocks in the Inner Drive Area shall be left unrecorded (also at finalization of the disk).

	Initial Zone	
Physical Sector 143 488	Inner Disk Test Zone 16 384 Physical Sectors	Physical Sector (023080)
Physical Sector 159 871 Physical Sector 159 872	Count Zone Run-in 1 024 Physical Sectors	Physical Sector (02707F) Physical Sector (027080)
Physical Sector 160 895 Physical Sector 160 896	Inner Disk Count Zone 4 096 Physical Sectors	Physical Sector (02747F) Physical Sector (027480)
Physical Sector 164 991 Physical Sector 164 992	Inner Disk Administration Zone 4 096 Physical Sectors	Physical Sector (02847F) Physical Sector (028480)
Physical Sector 169 087 Physical Sector 169 088	Table of Contents Zone 4 096 Physical Sectors	Physical Sector (02947F) Physical Sector (029480)
Physical Sector 173 183		Physical Sector (02A47F)
	Lead-in Zone	

Figure 23 – Inner Drive Area

17.1 Initial Zone

This Zone shall remain blank.

17.2 Inner Disk Test Zone

16 384 Physical Sectors reserved for drive testing and OPC algorithms (see Annex H). The order in which these Physical Sectors shall be used is from the outer side of the disk towards the inner side of the disk, so from the highest address towards the lowest address.

17.3 Count Zone Run-in

This area with the size of 1 024 Physical Sectors is meant as a Run-in area for the Inner Disk Count Zone and shall be left unrecorded.

17.4 Inner Disk Count Zone

4 096 Physical Sectors reserved for counting the number of OPC algorithms performed in the Inner Disk Test Zone (see Annex H).

Whenever an ECC Block or part of it in the Inner Disk Test Zone has been recorded, the ECC Block shall be flagged by recording 4 Physical Sectors in the Inner Disk Count Zone. These 4 Physical Sectors shall be formatted according to the rules specified in 13.1 and the underlying subclauses, 13.2, 13.4, 13.5 and 13.6, whereby the Main Data bytes and the PI and PO bytes (see 13.3) can be chosen freely.

The relation between the first Physical Sector number PSN_{IDT} of the used ECC Block in the Inner Disk Test Zone and the Physical Sector numbers PSN_{IDC} to $PSN_{IDC} + 3$ of the 4 Physical Sectors in the Inner Disk Count Zone is determined by the following mathematical expression:

$$PSN_{IDC} = \{(PSN_{IDT}) - (023080)\} / (04) + (027480)$$

17.5 Inner Disk Administration Zone

4 096 Physical Sectors to be used for optional drive specific information. The first 16 physical sectors of this Zone shall be filled with all Main Data set to (00).

Table 7 – General format of Disk Administration ECC Blocks

Physical Sector of each Adm. Block	Main Data BP	Description
0	D ₀ to D ₃	Content Descriptor
0	D ₄ to D ₇	Reserved and set (00)
0	D ₈ to D ₃₉	Drive ID
0	D ₄₀ to D ₆₃	Reserved and set (00)
0	D ₆₄ to D _{2 047}	Drive Specific
1 to 15	D ₀ - D _{2 047}	Drive Specific

Physical Sector 0 / bytes D₀ to D₃ – Content Descriptor

these bytes identify the Administration Block and shall be set to (41444D00), representing the characters “ADM” and the version number 0.

Physical Sector 0 / bytes D₄ to D₇ – Reserved

these bytes are reserved and shall be set to (00).

Physical Sector 0 / bytes D₈ to D₃₉ – Drive ID

these bytes shall contain the drive ID as specified in 25.1, bytes D₈ to D₃₉.

Physical Sector 0 / bytes D₄₀ to D₆₃ – Reserved

these bytes are reserved and shall be set to (00).

Physical Sector 0 / bytes D₆₄ to D_{2 047} – Drive Specific

these bytes can be used to store Drive Specific information. The format is not defined and can be freely chosen by the drive manufacturer.

Physical Sectors 1 to 15 / bytes D₀ to D_{2 047} – Drive Specific

these bytes can be used to store Drive Specific information. The format is not defined and can be freely chosen by the drive manufacturer.

17.6 Table of Contents (TOC) Zone

4 096 Physical Sectors to store information about the locations of Sessions and recordings on the disk. The first 16 physical sectors of this Zone shall be filled with all Main Data set to (00).

This Zone consists of 2 parts:

- part 1: consists of 191 ECC Blocks (TOC Blocks) to be used to store the locations of all Closed Sessions,
- part 2: consists of 1024 Physical Sectors, grouped in units of 4 sectors, where each unit corresponds to one ADIP word. These units shall be used as Recorded Area Indicators.

17.6.1 Table of Contents Blocks

Whenever a Session is closed, the next ECC Block in the Table of Contents Zone, immediately following the last TOC Block, shall be recorded with the locations of all Closed Sessions. The first ECC Block in the Table of Contents Zone has to be used as a run-in for the second ECC Block. If all 191 TOC Blocks have been used, no additional Sessions shall be added (see also 23.2 and 23.3).

The format of the TOC Blocks shall be as defined in Table 8:

Table 8 - Format of the TOC Blocks

Physical Sector of TOC block	Main Data byte position	Description	number of bytes
0	D ₀ to D ₃	Content Descriptor	4
0	D ₄ to D ₇	Reserved and set to (00)	4
0	D ₈ to D ₃₉	Drive ID	32
0	D ₄₀ to D ₆₃	Reserved and set to (00)	24
0	D ₆₄ to D ₇₉	TOC Item 0	16
0	...		
0	D _{64+i×16} to D _{79+i×16}	TOC Item i	16
0	
0	D _{64+(N-1)×16} to D _{79+(N-1)×16}	TOC Item N-1	16
0	D _{64+N×16} to D _{2 047}	Reserved and set to (00)	1 984 - N×16
1 to 3	D ₀ to D _{2 047}	Extension for TOC Items or Reserved and set to (00)	3×2 048
4 to 7	D ₀ to D _{2 047}	Repetition of Sectors 0 to 3 (recommended) or Reserved and set to (00)	4×2 048
8 to 11	D ₀ to D _{2 047}	Repetition of Sectors 0 to 3 (recommended) or Reserved and set to (00)	4×2 048
12 to 15	D ₀ to D _{2 047}	Repetition of Sectors 0 to 3 (recommended) or Reserved and set to (00)	4×2 048

Physical Sector 0 / bytes D₀ to D₃ – Content Descriptor

these bytes identify the TOC Block and shall be set to (544F4300), representing the characters “TOC” and the version number 0.

Physical Sector 0 / bytes D₄ to D₇ – Reserved

these bytes are reserved and shall be set to (00).

Physical Sector 0 / bytes D₈ to D₃₉ – Drive ID

these bytes shall contain the drive ID as specified in 25.1, bytes D₈ to D₃₉.

Physical Sector 0 / bytes D₄₀ to D₆₃ – Reserved

these bytes are reserved and shall be set to (00).

Physical Sector 0 / bytes D₆₄ to D_{2 047} – TOC Items

these bytes are grouped in units of 16 bytes each. Each unit of 16 bytes can contain a TOC Item according to the following format. All unused bytes shall be set to (00).

Physical Sectors 1 to 3 / bytes D₀ to D_{2 047} – Extension for TOC Items or Reserved

these bytes can be used to hold additional TOC Items.
All unused bytes shall be set to (00).

Physical Sectors 4 to 15 / bytes D₀ to D_{2 047} – Repetitions of Sectors 0 to 3 or all Reserved

For robustness reasons it is recommended to repeat the content of Sectors 0 to 3 in Sectors 4 to 7, in Sectors 8 to 11 and in Sectors 12 to 15.

If this option is not used, these bytes shall be set to (00).

It is a matter of drive implementation to recognize and make use of the repetitions.

17.6.1.1 TOC Items:

Item byte position	Description	number of bytes
B ₀ to B ₂	TOC Item descriptor	3
B ₃	Session Status	1
B ₄	Session number	1
B ₅ to B ₇	Session start address	3
B ₈ to B ₁₀	Session end address	3
B ₁₁ to B ₁₂	Last Fragment number in Session	2
B ₁₃ to B ₁₅	Reserved and set to (00)	3

The TOC Block shall contain a TOC Item for each Closed Session on the disk. The TOC Items shall be ordered with increasing numbers and addresses.

TOC Item bytes B₀ to B₂ – TOC Item descriptor

these 3 bytes identify the item type and shall be set to (544349), representing the characters "TCI".

TOC Item byte B₃ – Session Status

this byte shall indicate the Status of the last Session. It shall be set to (00) in all TOC Items, except in the TOC Item describing the last Session on the disk.

If set to (00) in the last TOC Item, adding a new Session to the disk is allowed.

If set to (01) in the last TOC Item, the last Session shall be the final Session on the disk. The disk has been finalized and adding new Sessions is not allowed (see 23.3).

TOC Item byte B₄ – Session number

this byte shall specify the sequence number of the Session specified in this item.

TOC Item bytes B₅ to B₇ – Session start address

these 3 bytes shall specify the PSN of the first Physical Sector in the Data Zone of the Session specified in this item.

TOC Item bytes B₈ to B₁₀ – Session end address

these 3 bytes shall specify the PSN of the last Physical Sector in the Data Zone of the Session specified in this item.

TOC Item bytes B₁₁ to B₁₂ – Last Fragment number in Session

these 2 bytes specify the sequence number of the last Fragment in the Session specified in this item. If this option is not used, these bytes shall be set to (00).

TOC Item bytes B₁₃ to B₁₅ – Reserved

these 3 bytes are reserved and shall be set to (00).

17.6.2 Recorded Area Indicators

To speed up the access of the disk, the recorder needs to know in which region of the disk the last written ECC Block can be found. For this purpose a kind of “bitmap” is defined, based on recorded areas with the size of 4 Physical Sectors, each area corresponding to one ADIP word. The 4 Physical Sectors shall be formatted according to the rules specified in 13.1 and the underlying subclauses, 13.2, 13.4, 13.5 and 13.6, whereby the Main Data bytes and the PI and PO bytes (see 13.3) can be chosen freely.

1 024 Physical Sectors have been reserved for this “bitmap” purpose, allowing to divide the disk into maximum 256 regions. The Recorded Area Indicators shall be used from the outer side of the TOC Zone towards the inner side of the TOC Zone (see Figure 24). By means of an “HF-detection” the recorder can find the locations of the Recorded Area Indicators and determine the regions which contain recorded ECC Blocks.

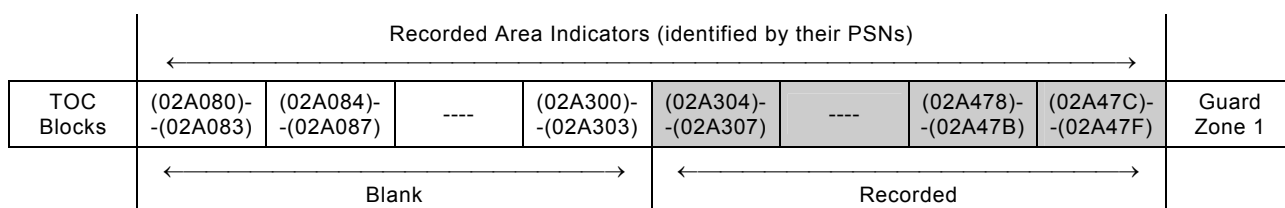

Figure 24 – Use of Recorded Area Indicators

Each region of 640 ECC Blocks between PSN = (030000) and PSN = (26053F) corresponds to one Recorded Area Indicator. All regions that contain one or more recorded ECC Blocks shall be indicated by their Recorded Area Indicator. In mathematical form:

if the Recorded Area Indicator composed of the Physical Sectors with PSN_{RAI} to PSN_{RAI} + 3 has been recorded, then the region between:

PSN = (02A47C)-(PSN_{RAI})×(A00)+(030000) and

PSN = {(02A47C)-(PSN_{RAI})×(A00)+(0327FF) contains recorded ECC Blocks,

or in decimal notation:

PSN = {173180-PSN_{RAI}}×2560+196608 and PSN = {173180-PSN_{RAI}}×2560+206847.

Whenever the disk is ejected from the drive, the Recorded Area Indicators shall reflect the actual status of the recordings on the disk.

18 Lead-in Zone

The Lead-in Zone is located at the inner side of the Information Zone. It shall consist of the parts shown in Figure 25.

The Physical Sector Number of the first and last Physical Sector of each part is indicated in Figure 25 in hexadecimal and decimal notation and the number of Physical Sectors in each part are indicated in decimal notation.

A maiden disk does not have any data recorded in the Lead-in Zone. After finalization of the disk or closing of the first Session, the Lead-in Zone shall be recorded according to 18.1 to 18.9.

18.1 Guard Zone 1

This Guard Zone is used to create a minimum amount of Lead-in Zone required for compatibility. This zone shall contain 14 848 Physical Sectors, all filled with Main Data set to (00).

18.2 Reserved Zone 1

4 096 Physical Sectors are reserved and shall be set (00).

18.3 Reserved Zone 2

64 Physical Sectors are reserved and shall be set (00).

Inner Drive Area		
Physical Sector 173 184	Guard Zone 1 14 848 Physical Sectors with Main Data set to (00)	Physical Sector (02A480)
Physical Sector 188 031 Physical Sector 188 032	Reserved Zone 1 4 096 Physical Sectors	Physical Sector (02DE7F) Physical Sector (02DE80)
Physical Sector 192 127 Physical Sector 192 128	Reserved Zone 2 64 Physical Sectors	Physical Sector (02EE7F) Physical Sector (02EE80)
Physical Sector 192 191 Physical Sector 192 192	Inner Disk Identification Zone 256 Physical Sectors	Physical Sector (02EEBF) Physical Sector (02EEC0)
Physical Sector 192 447 Physical Sector 192 448	Reserved Zone 3 64 Physical Sectors	Physical Sector (02EFBF) Physical Sector (02EFC0)
Physical Sector 192 511 Physical Sector 192 512	Reference Code Zone 32 Physical Sectors	Physical Sector (02EFFF) Physical Sector (02F000)
Physical Sector 192 543 Physical Sector 192 544	Buffer Zone 1 480 Physical Sectors with Main Data set to (00)	Physical Sector (02F01F) Physical Sector (02F020)
Physical Sector 193 023 Physical Sector 193 024	Control Data Zone 3 072 Physical Sectors	Physical Sector (02F1FF) Physical Sector (02F200)
Physical Sector 196 095 Physical Sector 196 096	Buffer Zone 2 512 Physical Sectors with Main Data set to (00)	Physical Sector (02FDFF) Physical Sector (02FE00)
Physical Sector 196 607	Data Zone	Physical Sector (02FFFF)

Figure 25 - Lead-in Zone

18.4 Inner Disk Identification Zone

256 Physical Sectors reserved for information agreed upon by the data interchange parties. Each set of 16 Physical Sectors from one ECC Block is either a Disk Control Block (DCB) (see Clause 25) or recorded with all (00) Main Data. Each ECC Block in this Zone following one recorded with all (00) Main Data shall also be recorded with all (00) Main Data.

18.5 Reserved Zone 3

64 Physical Sectors are reserved and shall be set (00).

18.6 Reference Code Zone

The recorded Reference Code Zone shall consist of the 32 Physical Sectors from two ECC Blocks which generate a specific Channel bit pattern on the disk. This shall be achieved by setting to (AC) all 2 048 Main Data bytes of each corresponding Data Frame. Moreover, no scrambling shall be applied to these Data Frames, except to the first 160 Main Data bytes of the first Data Frame of each ECC Block.

18.7 Buffer Zone 1

This Zone shall consist of 480 Physical Sectors from 30 ECC Blocks. The Main Data of the Data Frames in this Zone shall be set to all (00).

18.8 Control Data Zone

This Zone shall consist of 3 072 Physical Sectors from 192 ECC Blocks. The content of the 16 Physical Sectors of each ECC Block is repeated 192 times. The structure of a Control Data Block shall be as shown in Figure 26.

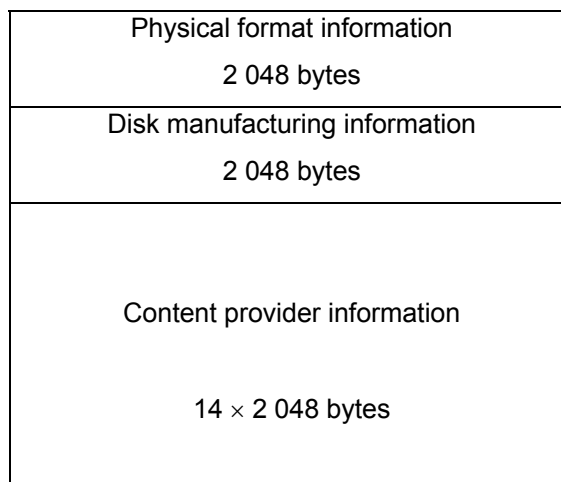

Figure 26 - Structure of a Control Data Block

18.8.1 Physical format information

This information shall comprise the 2 048 bytes shown in Table 9. It contains disk and format information.

Table 9 - Physical format information

Byte number	Content	Number of bytes
0	Disk Category and Version Number	1
1	Disk size	1
2	Disk structure	1
3	Recording density	1
4 to 15	Data Zone allocation	12
16	Set to (00)	1
17	Disk Application Code	1
18	Extended Information indicators	1
19 to 26	Disk Manufacturer ID	8
27 to 29	Media type ID	3
30	Product revision number	1
31	number of Physical format information bytes in use in ADIP up to byte 63	1
32	Primary recording velocity for the basic write strategy	1
33	Upper recording velocity for the basic write strategy	1
34	Wavelength λ_{IND}	1
35	normalized Write power dependency on Wavelength $(dP/d\lambda)/(P_{IND}/\lambda_{IND})$	1
36	Maximum read power at Primary velocity	1

Byte number	Content	Number of bytes
37	P _{IND} at Primary velocity	1
38	β _{target} at Primary velocity	1
39	Maximum read power at Upper velocity	1
40	P _{IND} at Upper velocity	1
41	β _{target} at Upper velocity	1
42	T _{top} (≥4) first pulse duration for cm ≥4 at Primary velocity	1
43	T _{top} (=3) first pulse duration for cm =3 at Primary velocity	1
44	T _{mp} multi pulse duration at Primary velocity	1
45	T _{lp} last pulse duration at Primary velocity	1
46	dT _{top} (≥4) first pulse lead time for cm ≥4 at Primary velocity	1
47	dT _{top} (=3) first pulse lead time for cm =3 at Primary velocity	1
48	dT _{le} first pulse leading edge correction for ps=3 at Primary velocity	1
49	T _{top} (≥4) first pulse duration for cm ≥4 at Upper velocity	1
50	T _{top} (=3) first pulse duration for cm =3 at Upper velocity	1
51	T _{mp} multi pulse duration at Upper velocity	1
52	T _{lp} last pulse duration at Upper velocity	1
53	dT _{top} (≥4) first pulse lead time for cm ≥4 at Upper velocity	1
54	dT _{top} (=3) first pulse lead time for cm =3 at Upper velocity	1
55	dT _{le} first pulse leading edge correction for ps =3 at Upper velocity	1
56 to 63	Reserved - All (00)	8
64 to 95	Extended Information block 0	32
96 to 127	Extended Information block 1	32
128 to 159	Extended Information block 2	32
160 to 191	Extended Information block 3	32
192 to 223	Extended Information block 4	32
224 to 247	Extended Information block 5	24
248 to 251	Start of Session	4
252 to 255	End of Session	4
256 to 2 047	Reserved – All (00)	1792

The information in bytes 0 to 255 have the same definitions and shall have the same contents as the Physical format information in ADIP defined in Table 3 and 14.4.2, except the following bytes:

Byte 1 – Disk size and maximum transfer rate

Bits b₇ to b₄ same as 14.4.2

Bits b₃ to b₀ shall specify the maximum read transfer rate.

These bits may be set to one of the following values (depending on the maximum read-out speed needed by the application):

0000: specify a maximum transfer rate of 2,52 Mbits/s (See note at 30.3)

0001: specify a maximum transfer rate of 5,04 Mbits/s (See note at 30.3)

0010: specify a maximum transfer rate of 10,08 Mbits/s

1111: specify no maximum transfer rate is specified.

All other combinations are reserved and shall not be used.

Bytes 4 to 15 – Data Zone allocation

Bytes 4 to 8 same as 14.4.2

Bytes 9 to 11 on a finalized Single Session disk (see 23.3):
shall specify the Sector Number of the last Physical Sector of the Data Zone.
on a Multi-session disk (see Clause 22):
shall be set to (26053F) to specify PSN 2 491 711 as the last possible
Physical Sector on the disk for the storage of User Data (see also Annex A).

Bytes 12 to 15 same as 14.4.2

Bytes 248 to 251 – Start of first Session

Byte 248 shall be set to (00).

Bytes 249 to 251 shall be set to (030000) to specify PSN 196 608 of the first Physical Sector of the Data Zone of the first Session (see Clause 22).

Bytes 252 to 255 – End of first Session

Byte 252 shall be set to (00).

Bytes 253 to 255 shall specify the Sector Number of the last Physical Sector of the Data Zone of the first Session (see Clause 22).

Bytes 256 to 2 047 – Reserved - All (00)

These remaining bytes have no relation to the ADIP information and shall be set to all (00).

18.8.2 Disk manufacturing information

This Ecma Standard does not specify the format and the content of these 2 048 bytes. They shall be ignored in interchange.

18.8.3 Content provider information

These 28 672 bytes shall be set to all (00).

Under no circumstance may data received from the host be recorded in this field.

***Circumvention:** Recorders and recording drives shall be considered as circumvention devices when these are produced to record, or can easily be modified to record, in any manner, a user-defined number in this field.*

18.9 Buffer Zone 2

This recorded Zone shall consist of 512 Physical Sectors from 32 ECC Blocks. The Main Data of the Data Frames in this Zone shall be set to all (00).

19 Data Zone

2 295 104 Physical Sectors for the storage of user data (see also Annex A).

The start radius of the Data Zone is determined by the location of ADIP Physical Address (00C000) and the maximum end radius is determined by the location of ADIP Physical Address (098150) (see 14.4.1.1, bit 2 to 23 and 13.7.1)

20 Lead-out Zone

The Lead-out Zone is located at the outer side of the Information Zone. It shall consist of the parts specified in Figure 27. The Physical Sector Number of the first and the last Physical Sector of each part is indicated in Figure 27 in hexadecimal and decimal notation and the number of Physical Sectors in each part is indicated in decimal notation. (see also Annex A)

	Data Zone	
Physical Sector 2 491 712 max	Buffer Zone 3 768 Physical Sectors with Main Data set to (00)	Physical Sector (260540) max
Physical Sector 2 492 479 max	Outer Disk Identification Zone 256 Physical Sectors	Physical Sector (26083F) max
Physical Sector 2 492 480 max		Physical Sector (260840) max
Physical Sector 2 492 735 max	Guard Zone 2 min 4 096 Physical Sectors with Main Data set to (00) (remaining sectors are allowed to be unrecorded)	Physical Sector (26093F) max
Physical Sector 2 492 736 max		Physical Sector (260940) max
Physical Sector 2 496 831	Outer Drive Area	Physical Sector (26193F)

Figure 27 - Lead-out Zone

20.1 Buffer Zone 3

This recorded Zone shall consist of 768 Physical Sectors. The last possible start location of Buffer Zone 3 is (260540) (see also Annex A). The Main Data of the Data Frames in this Zone shall be set to all (00).

20.2 Outer Disk Identification Zone

256 Physical Sectors reserved for information agreed upon by the data interchange parties. Each set of 16 Physical Sectors from one ECC Block is either a Disk Control Block (DCB) (see Clause 25) or recorded with all (00) Main Data. The contents of this Zone shall be equivalent to the contents of the last Inner Session Identification Zone (or to the contents of the Inner Disk Identification Zone in case of a Single-session disk).

20.3 Guard Zone 2

This Guard Zone is used as a protection for separating test writing zones from information zones containing user data. This zone shall contain a minimum of 4 096 Physical Sectors filled with Main Data set to (00).

If the total storage capacity of the disk is not fully used, the Guard Zone 2 can be extended with Physical Sectors filled with Main Data set to (00) to fill up the gap up to a certain radius or up to the Outer Drive Area, or this gap can be left unrecorded. The choice for these options is left to the drive manufacturer.

21 Outer Drive Area

The Outer Drive Area is the outermost zone of the disk which is used by the drive for performing disk tests and OPC algorithms. It shall consist of the parts shown in Figure 28.

The Physical Sector Number of the first and last Physical Sector of each part is indicated in Figure 28 in hexadecimal and decimal notation and the number of Physical Sectors in each part are indicated in decimal notation. (see also Annex A)

Lead-out Zone		
Physical Sector 2 496 832	Outer Disk Administration Zone 4 096 Physical Sectors	Physical Sector (261940)
Physical Sector 2 500 927	Outer Disk Count Zone 4 096 Physical Sectors	Physical Sector (26293F)
Physical Sector 2 500 928		Physical Sector (262940)
Physical Sector 2 505 023	Outer Disk Test Zone 16 384 Physical Sectors	Physical Sector (26393F)
Physical Sector 2 505 024		Physical Sector (263940)
Physical Sector 2 521 407	Guard Zone 3 Blank	Physical Sector (26793F)
Physical Sector 2 521 408		Physical Sector (267940)

Figure 28 – Outer Drive Area

21.1 Outer Disk Administration Zone

4 096 Physical Sectors to be used for optional drive specific information. The first 16 physical sectors of this Zone shall be filled with all Main Data set to (00). This zone can be used in the same way as the Inner Disk Administration Zone (see 17.5).

21.2 Outer Disk Count Zone

4 096 Physical Sectors reserved for counting the number of OPC algorithms performed in the Outer Disk Test Zone (see Annex H).

Whenever an ECC Block or part of it in the Outer Disk Test Zone has been recorded, the ECC Block shall be flagged by recording 4 Physical Sectors in the Outer Disk Count Zone. These 4 Physical Sectors shall be formatted according to the rules specified in 13.1 and the underlying subclauses, 13.2, 13.4, 13.5 and 13.6, whereby the Main Data bytes and the PI and PO bytes (see 13.3) can be chosen freely.

The relation between the first Physical Sector number PSN_{ODT} of the used ECC Block in the Outer Disk Test Zone and the Physical Sector numbers PSN_{ODC} to $PSN_{ODC} + 3$ of the 4 Physical Sectors in the Outer Disk Count Zone is determined by the following mathematical expression (see also Annex A):

$$PSN_{ODC} = \{(PSN_{ODT}) - (263940)\} / (04) + (262940)$$

21.3 Outer Disk Test Zone

16 384 Physical Sectors reserved for drive testing and OPC algorithms (see Annex H). The order in which these Physical Sectors shall be used is from the outer side of the disk towards the inner side of the disk, so from the highest address towards the lowest address.

21.4 Guard Zone 3

This Zone shall remain blank.

22 Multi-session Layout

To enable data retrieval by Read-Only devices, the disk should have a Lead-in Zone, no blank areas in the Data Zone, and some form of Lead-out Zone. However one also wants to have the ability to append additional data to a partially recorded disk. For this purpose the following Multi-session concept is specified.

On a Multi-session disk there can exist more than one session. A session with an Intro and a Closure is called a Closed Session. The first Session shall be preceded by a Lead-in Zone instead of an Intro Zone, the final Session shall be followed by a Lead-out Zone instead of a Closure Zone. Once a Lead-out Zone has been recorded, the disk is called “finalized” and no additional recordings to the disk shall be allowed.

The general layout of a Multi-session disk is shown in Table 10.

Table 10 - Layout of the Information Zone of a Multi-session disk

Session	Zone	Description	Number of Physical Sectors	
	Inner Drive Area	--	--	
<i>Session 1</i>	Lead-in	
		Reserved Zone 2	64	
		Inner Disk Identification Zone	256	
		
		Control Data Zone	3 072	
		Buffer Zone 2	512	
	Data	Data Zone	min 16	
	Closure	Buffer Zone C	See 22.2	768
Outer Session Identification Zone		256		
<i>Session 2</i>	Intro	Buffer Zone A	See 22.1	64
		Inner Session Identification Zone		256
		Session Control Data Zone		640
		Buffer Zone B		64
	Data	Data Zone	min 16	
	Closure	Buffer Zone C	See 22.2	768
		Outer Session Identification Zone		256
•	•	•	...	
•	•	•	...	
<i>Session N</i> ($N \leq 191$)	Intro	...	See 22.1	...
	Data	Data Zone		min 16
	Lead-out	Buffer Zone 3	See Clause 20	768
		Outer Disk Identification Zone		256
	
	Outer Drive Area	--	--	

A session with a partially recorded Lead-in or Intro Zone and no Lead-out or Closure Zone is called an Open Session. All sessions must be Closed Sessions, except for the last one, which is allowed to be an Open Session. User Data can only be appended to an Open Session. If all sessions are closed, a new Open Session has to be created first (see 23.1).

The first Closed Session on the disk shall have a Lead-in that complies with Clause 18. Subsequent Closed Sessions shall have an Intro as defined in 22.1. Every Closed Session shall have a Closure as defined in 22.2, except for the Final Session, which shall have a Lead-out as defined in Clause 20.

22.1 Intro

Each new Session that occurs after the first Session, shall start with an Intro Zone consisting of a Buffer Zone A, an Inner Session Identification Zone, a Session Control Data Zone and a Buffer Zone B.

All Physical Sectors in the Intro Zone shall have bits b_{27} to b_{26} of the Data Frame set to ZERO ZERO, identifying the Intro Zone as if it was a Data Zone (see 13.1.1).

22.1.1 Buffer Zone A

64 Physical Sectors are reserved and shall be set (00).

22.1.2 Inner Session Identification Zone

256 Physical Sectors reserved to store information about the Sessions. Each set of 16 Physical Sectors from one ECC Block is either a Disk Control Block (DCB) (see Clause 25) or recorded with all (00) Main Data. Each ECC Block in this Zone following one recorded with all (00) Main Data shall also be recorded with all (00) Main Data.

22.1.3 Session Control Data Zone

This Zone shall consist of 640 Physical Sectors from 40 ECC Blocks. The content of the 16 Physical Sectors of each ECC Block is repeated 40 times. The structure of a Control Data Block shall be as shown in Figure 26.

22.1.4 Buffer Zone B

64 Physical Sectors are reserved and shall be set (00).

22.2 Data Zone

Each Data Zone shall consist of a multiple of 16 Physical Sectors, with a minimum of 16. The first Data Zone shall start at PSN (030000). If needed (e.g. for filling up the last ECC Block or for facilitating compatibility with certain Read-Only drives that require the disk to be recorded up till a certain radius) a Data Zone can be padded with Data Frames containing all (00) Main Data.

22.3 Closure

Each Session shall end with a Closure Zone consisting of two parts; a Buffer Zone C and an Outer Session Identification Zone.

All Physical Sectors in the Closure Zone shall have bits b_{27} to b_{26} of the Data Frame set to ZERO ZERO, identifying the Closure Zone as if it was a Data Zone (see 13.1.1).

22.3.1 Buffer Zone C

768 Physical Sectors are reserved and shall be set (00).

22.3.2 Outer Session Identification Zone

Each set of 16 Physical Sectors from one ECC Block is either a Disk Control Block (DCB) (see Clause 25) or recorded with all (00) Main Data. The contents of this Zone shall be equivalent to the contents of the Inner Identification Zone of the same Session.

23 Sequential recording in Fragments

+R disks according to this document in principle have to be recorded sequentially. To facilitate the recording of specific data at some pre-determined location on the disk at a later moment in time (such as for instance File System information), a Session can be divided into a number of Fragments. Inside such a Fragment the User Data shall be recorded sequentially from the inner side of the disk towards the outer side of the disk

23.1 Opening a Session

New data can be added to the disk by appending to an Open Session. If there is no Open Session, a new Session has to be opened (see Table 11).

A new Session is opened by recording Buffer Zone A plus an SDCB (Session Disk Control Block: see 25.2) in the first ECC Block of the Inner Session Identification Zone (or by recording Reserved Zone 2 plus an SDCB in the first ECC Block of the Inner Disk Identification Zone in case of the first Session on a blank disk).

Buffer Zone B of the Intro (or Buffer Zone 2 of the Lead-in Zone in case of the first Session on a blank disk) shall be recorded at the same time the first ECC Block of the Data Zone is recorded.

Table 11 – Details of opened Session n (example)

	<u>Data</u>	Data Zone	User Data
Session n-1		Buffer Zone C	48 ECC Blocks with (00)
	<u>Closure</u>	Outer Session Identification Zone	16 ECC Blocks with DCBs and/or (00)
Session n	<u>Intro</u>	Buffer Zone A	4 ECC Blocks with (00)
		Inner Session Identification Zone	1 ECC Block with an SDCB
			blank
		Session Control Data Zone	blank
	Buffer Zone B	4 ECC Blocks with (00)	
	<u>Data</u>	Data Zone	Reserved Fragment (optional)
			1 ECC Block for Run-in
			Incomplete Fragment with User Data
blank			

23.1.1 Incomplete Fragment

When no Reserved Fragments (see 23.1.1) are created, all the remaining area of the Data Zone following Buffer Zone B is called the Incomplete Fragment. In the presence of Reserved Fragments, all the remaining area of the Data Zone following the last Reserved Fragment is called the Incomplete Fragment.

Until the Incomplete Fragment is closed (see 23.1.4), there shall be no Fragment item (see 25.2.1) for the Incomplete Fragment in any SDCB.

23.1.2 Reserved Fragments

To allow for later on adding data, preceding already recorded User Data (such as for instance File System information), it is possible to create so-called Reserved Fragments. All Reserved Fragments in the Open Session shall be contiguous and non-overlapping, while the first Fragment shall start immediately after the end of Buffer Zone B.

Between any 2 Fragments there shall be 1 ECC Block for Run-in purposes. This ECC Block does not belong to any of the Fragments, and shall be recorded after the end of Reserved Fragment i at the same time the first ECC Block of Fragment $(i+1)$ is recorded (see Figure 29).

23.1.2.1 Adding a Reserved Fragment

If a new Reserved Fragment is defined, this Fragment shall start from the beginning of the Incomplete Fragment and at least include all data that have already been written to the Incomplete Fragment. The newly defined Reserved Fragment shall be Fragment $n+1$, where n is the number of the previously last (Reserved) Fragment. A new SDCB shall be recorded in the Identification Zone of the Session including a new Fragment item indicating the start and end addresses of the added Reserved Fragment (see 25.2.1).

Reserved Fragments can only be added as long as the number of free locations for SDCBs in the Inner Identification Zone of the current Session is larger than one. The last free location for an SDCB has to be preserved for closing the Session.

The area following the newly defined Reserved Fragment is designated to be the new Incomplete Fragment ($n+2$).

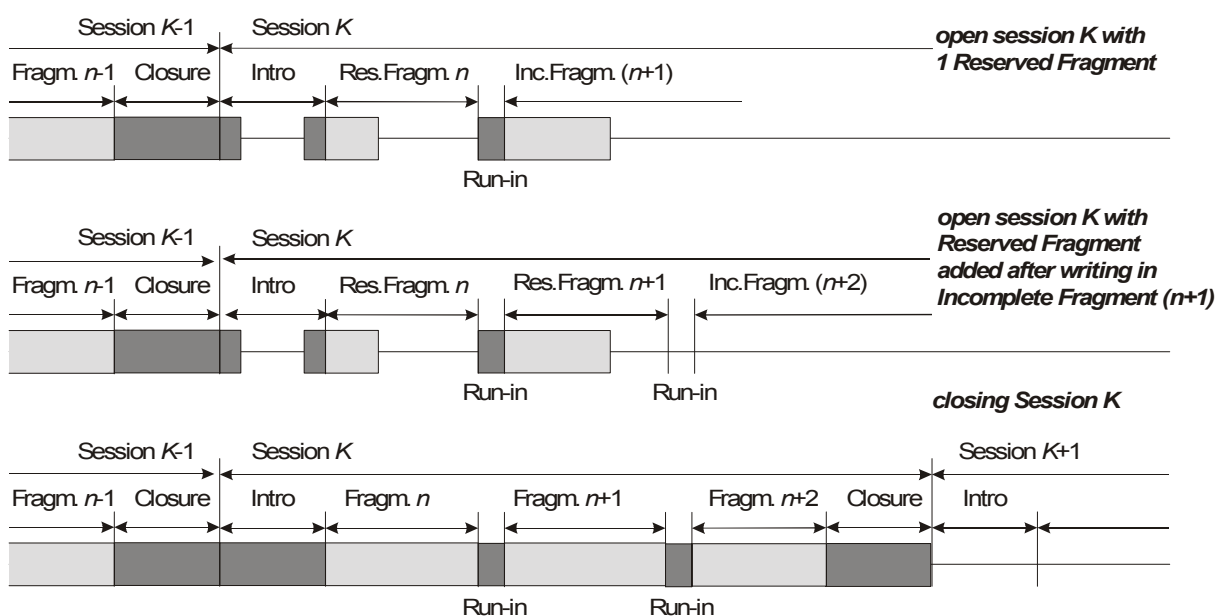

Figure 29 – Creating Reserved Fragments

23.1.3 Recording User Data in Fragments

User Data added to the Data Zone shall be linked immediately to previously written User Data in the Incomplete Fragment or to previously written data in one of the Reserved Fragments.

23.1.4 Closing a Fragment

When a Reserved Fragment is closed, all blank areas in the Fragment shall be recorded with dummy data.

When the Incomplete Fragment is closed, a new SDCB shall be recorded in the Identification Zone of the Session including a new Fragment item indicating the start and end addresses of the (formerly) Incomplete Fragment (see 25.2). This formerly Incomplete Fragment shall not have unrecorded areas.

The area after the formerly Incomplete Fragment can be designated as the new Incomplete Fragment is case more User Data has to be added. For consistency reasons a Run-in Block shall be taken into account between the new Incomplete Fragment and the formerly Incomplete Fragment.

23.2 Closing a Session

To enable data retrieval from a Session by Read-Only devices, this Session and all preceding ones should be closed. A Session is closed by recording all blank areas in all Fragments with dummy data and recording all remaining parts in the Lead-in or Intro Zone and adding the Closure Zone.

When a Session is closed, the Incomplete Fragment is closed and shall be designated as Fragment $m+1$, where m is the number of the last (Reserved) Fragment preceding the Incomplete Fragment (see Figure 29).

The numbering of the Fragments shall be continuous over all Sessions (see Figure 29).

When the Session to be closed is the 191st Session, then the disk shall be finalized, instead of closing the Session (see 23.3).

Also when the remaining free space on the disk after closing the Session will become less than 128 ECC Blocks (2048 Physical Sectors), the disk shall be finalized, instead of closing the Session (see 23.3.).

23.2.1 Lead-in/Intro Zone

The SDCB shall be updated, including the Incomplete Fragment as the last Fragment ($n+2$ in the example of Figure 29). In case multiple SDCBs have been recorded, the last written SDCB is the valid one.

In the Lead-in Zone the Control Data Zone shall be according to 18.8.

In each Intro the Session Control Data Zone shall be recorded with 40 ECC Blocks according to the format specified in 18.8 with the following settings:

Physical Format Information:

Bytes 0 to 247 – same as in 18.8.1

These bytes contain a copy of the Physical format information.

Bytes 248 to 251 – Start of current Session

Byte 248 shall be set to (00).

Bytes 249 to 251 shall specify the Sector Number of the first Physical Sector of the Data Zone of the current Session (see Clause 22).

Bytes 252 to 255 – End of current Session

Byte 252 shall be set to (00).

Bytes 253 to 255 shall specify the Sector Number of the last Physical Sector of the Data Zone of the current Session (see Clause 22).

Bytes 256 to 2 047 – Reserved - All (00)

These remaining bytes have no relation to the ADIP information and shall be set to all (00).

Disk manufacturing information: see 18.8.2.

Content provider information: see 18.8.3.

23.2.2 Closure Zone

At closing a Session, Buffer Zone C shall be recorded together with the Outer Session Identification Zone.

23.3 Finalizing the disk

When the disk is being finalized, a Lead-out Zone according to Clause 20 shall be recorded instead of a Closure Zone. After finalizing the disk, adding data is no longer possible. The Session Status in the TOC Item describing the last Session shall be set accordingly (see 17.6.1: TOC Item, byte B_3).

24 Assignment of Logical Sector Numbers (LSNs)

Logical Sector Numbers (LSN) shall be assigned contiguously from LSN 0, starting from the first PSN of the first Data Zone to the end of the last Data Zone. The relation between LSN and PSN shall be: $LSN = PSN - (030000)$.

25 Disk Control Blocks

Disk Control ECC Blocks are provided as a structure on the disk to include additional information for interchange between the data interchange parties. DCBs are recorded in the Inner and Outer Identification Zones of the disk and the Sessions. All DCBs shall have the same format for the first 40 data bytes. A special DCB is defined to reflect the status of the Session(s).

25.1 General format of Disk Control Blocks

The Main Data of each Disk Control Block shall be according to Table 12.

If a Disk Control Block has to be updated, a substitute DCB shall be written immediately following the last written DCB in the Inner Disk/Session Identification Zone. If more than one DCB with the same Content Descriptor are present, then the one with the highest address is the only valid one of that type. Once a Session has been closed, the DCBs of that Session can no longer be updated.

Table 12 – General format of each Disk Control Block

Physical Sector of each DCB	Main Data BP	Description
0	D ₀ to D ₃	Content Descriptor
0	D ₄ to D ₇	Unknown Content Descriptor Actions
0	D ₈ to D ₃₉	Drive ID
0	D ₄₀ to D _{2 047}	Content Descriptor Specific
1 to 15	D ₀ - D _{2 047}	Content Descriptor Specific

Bytes D₀ to D₃ – Content Descriptor

if set to (00000000)

the DCB is unused.

The Content Descriptor of all subsequent DCBs in this Inner or Outer Identification Zone shall be set to (00000000).

All remaining bytes, D₄ to D_{2 047} of Physical Sector 0 and D₀ to D_{2 047} of Physical Sector 1 to 15 in Table 12 shall be set to (00).

if set to (53444300)

this DCB shall be as defined in 25.2.

All other values for the Content Descriptor are reserved.

Each new DCB added to the Inner or the Outer Identification Zone shall be written at the first available unwritten DCB location.

Each prevailing DCB with a Content Descriptor not set to (00000000) in the Inner Identification Zone of a Session shall have an identical DCB in the Outer Identification Zone of the respective Session (DCBs that have been substituted need not to be present in the Outer Identification Zone).

Bytes D₄ to D₇ – Unknown Content Descriptor Actions

These bits are provided to specify required actions when the content and use of the DCB are unknown to the drive (i.e. the content descriptor is not set to a known assigned value). These bytes form a field consisting of 32 individual bits.

- Bits b₃₁ to b₄ Reserved
These bits shall be set to all ZERO.
- Bit b₃ DCB rewrite
if set to ONE, substituting the current DCB shall not be allowed, else it shall be set to ZERO.
- Bit b₂ Formatting
shall be set to ONE, indicating that reformatting of the disk is not possible.
- Bit b₁ DCB read protect
if set to ONE, the information in this DCB is meant for use by the drive only and shall not be transferred outside the drive, else it shall be set ZERO.
- Bit b₀ Data Zone write
if set to ONE, recording shall not be allowed in the Data Zone, else it shall be set to ZERO.

Bytes D₈ to D₃₉ Drive ID

Bytes D₈ to D₃₉ shall contain a unique descriptor, identifying the drive that has written the DCB. The format of this unique drive identifier shall be as follows:

- Bytes D₈ to D₂₃ shall identify the manufacturer of the drive. This name shall be represented by characters from the G0 set + SPACE according to ECMA-43. Trailing bytes not used shall be set to (00).
- Bytes D₂₄ to D₃₅ shall identify the model name/type number of the drive. This model name/type number shall be represented by characters from the G0 set + SPACE according to ECMA-43. Trailing bytes not used shall be set to (00).
- Bytes D₃₆ to D₃₉ shall contain a unique serial number of the drive. The 4 bytes shall form one 32-bit binary number.

Bytes D₄₀ to D_{2 047} - Content Descriptor Specific

Bytes specified by the format description for the DCB with the actual Content Descriptor value.

Physical Sectors 1 to 15: Bytes D₀ to D_{2 047} Content Descriptor Specific

Bytes specified by the format description for the DCB with the actual Content Descriptor value.

25.2 Format of the Session DCB (SDCB)

The Lead-in or Intro Zone of an Open Session shall contain an SDCB describing the structure of the Open Session and the location of all previous Sessions. When the Session is closed, the SDCB in the Inner Identification Zone shall be updated and a copy shall be written to the Outer Identification Zone. The SDCB's shall have the content as defined in Table 13.

Table 13 - Format of the SDCB

Physical Sector of ECC block	Main Data byte position	Description	number of bytes
0	D ₀ to D ₃	Content Descriptor	4
0	D ₄ to D ₇	Unknown Content Descriptor Actions	4
0	D ₈ to D ₃₉	Drive ID	32
0	D ₄₀ to D ₄₁	Session number	2
0	D ₄₂ to D ₆₃	Reserved and set to (00)	22
0	D ₆₄ to D ₉₅	Disk ID (in Lead-in Zone only)	32
0	D ₉₆ to D ₁₂₇	Application Dependent	32
0	D ₁₂₈ to D ₁₄₃	Session Item 0	16
0	
0	D _{128+i×16} to D _{143+i×16}	Session Item i	16
0	
0	D _{128+(N-1)×16} to D _{143+(N-1)×16}	Session Item N-1	16
0	D _{128+N×16} to D _{2 047}	Reserved and set to (00)	1 920 - N×16
1 to 3	D ₀ to D _{2 047}	Extension for Session Items or Reserved and set to (00)	3×2 048
4 to 7	D ₀ to D _{2 047}	Repetition of Sectors 0 to 3 (recommended) or Reserved and set to (00)	4×2 048
8 to 11	D ₀ to D _{2 047}	Repetition of Sectors 0 to 3 (recommended) or Reserved and set to (00)	4×2 048
12 to 15	D ₀ to D _{2 047}	Repetition of Sectors 0 to 3 (recommended) or Reserved and set to (00)	4×2 048

Physical Sector 0 / bytes D₀ to D₃ – Content Descriptor

these bytes identify the Session DCB and shall be set to (53444300), representing the characters “SDC” and the version number 0.

Physical Sector 0 / bytes D₄ to D₇ – Unknown Content Descriptor Actions

shall be set to (0000000D) indicating that if this DCB is not known to the system, the DCB shall not be substituted, the disk can not be reformatted, writing to the Data Zone shall not be allowed, while transferring the DCB information from the drive to the host computer is allowed.

Physical Sector 0 / bytes D₈ to D₃₉ – Drive ID

these bytes shall contain the drive ID as specified in 25.1, bytes D₈ to D₃₉.

Physical Sector 0 / bytes D₄₀ to D₄₁ – Session number

these bytes shall specify the sequence number of the Session to which the SDCB belongs. The first Session shall have sequence number 1 and each subsequent Session number shall be incremented by one.

Physical Sector 0 / bytes D₄₂ to D₆₃ – Reserved

these bytes are reserved and shall be set to (00).

Physical Sector 0 / bytes D₆₄ to D₉₅ – Disk ID

In the SDCB in the Inner Disk Identification Zone in the Lead-in Zone of the disk, these 32 bytes shall be recorded with a random, statistically unique, 256-bit binary number at initialization of the disk (opening of the first Session). In the SDCB in the Inner Session Identification Zone in the Intro of each next Session, bytes D₆₄ to D₉₅ shall be set to all (00).

Physical Sector 0 / bytes D₉₆ to D₁₂₇ – Application dependent

this field shall consist of 32 bytes and is reserved for use by the application to store information such as specific copy protection data. If this setting is not specified by the application, the bytes shall be set to (00).

In each Session these bytes can be set independently.

Physical Sector 0 / bytes D₁₂₈ to D_{2 047} – Session Items

these bytes are grouped in units of 16 bytes each. Each unit of 16 bytes can contain one of two different types of Session Items:

- type 1: specifies the Fragments in the current Session,
- type 2: specifies the start and end addresses of all previous Sessions.

All unused bytes shall be set to (00).

Physical Sectors 1 to 3 / bytes D₀ to D_{2 047} – Extension for Session Items or Reserved

these bytes can be used to hold additional Session Items.

All unused bytes shall be set to (00).

Physical Sectors 4 to 15 / bytes D₀ to D_{2 047} – Repetitions of Sectors 0 to 3 or all Reserved

For robustness reasons it is recommended to repeat the content of Sectors 0 to 3 in Sectors 4 to 7, in Sectors 8 to 11 and in Sectors 12 to 15.

If this option is not used, these bytes shall be set to (00).

It is a matter of drive implementation to recognize and make use of the repetitions.

25.2.1 Session Items

25.2.1.1 type 1: Fragment item

Item byte position	Description	number of bytes
B ₀ to B ₂	Fragment item descriptor	3
B ₃ to B ₄	Fragment number	2
B ₅ to B ₇	Fragment start address	3
B ₈ to B ₁₀	Fragment end address	3
B ₁₁ to B ₁₅	Reserved and set to (00)	5

An SDCB can contain more than 1 Fragment item. If there are no Reserved Fragments, there shall be no Fragment items.

If a new Reserved Fragment has to be added to an Open Session, a new SDCB, including the Fragment items needed to reflect the new situation, is written in the Inner Identification Zone of

the current Session, immediately following the last SDCB. Reserved Fragments in a Session shall not be overlapping.

When closing a Session, a new SDCB, including a Fragment item for the Incomplete Fragment, is written in the Inner Identification Zone of the current Session, immediately following the last SDCB.

The Fragment items shall be ordered with increasing numbers and addresses. The last written SDCB in the Inner Identification Zone is the valid SDCB.

Fragment item bytes B₀ to B₂ – Fragment item descriptor

these 3 bytes identify the item type and shall be set to (465247), representing the characters “FRG”.

Fragment item bytes B₃ to B₄ – Fragment number

these 2 bytes shall specify the sequence number of the Fragment. The numbers of the Fragments shall be contiguous over all Sessions and increment by one for each subsequent Fragment. The first Fragment in the first Session shall have sequence number 1 and the first Fragment in each next Session shall have a sequence number that is one higher than the number of the last Fragment in the preceding Session.

Fragment item bytes B₅ to B₇ – Fragment start address

these 3 bytes shall specify the PSN of the first Physical Sector belonging to the Fragment specified in this item.

Fragment item bytes B₈ to B₁₀ – Fragment end address

these 3 bytes shall specify the PSN of the last Physical Sector belonging to the Fragment specified in this item.

Fragment item bytes B₁₁ to B₁₅ – Reserved

these 5 bytes are reserved and shall be set to (00).

25.2.1.2 type 2: Previous Session item

Item byte position	Description	number of bytes
B ₀ to B ₂	Previous Session item descriptor	3
B ₃	Reserved and set to (00)	1
B ₄	Previous Session number	1
B ₅ to B ₇	Previous Session start address	3
B ₈ to B ₁₀	Previous Session end address	3
B ₁₁ to B ₁₅	Reserved and set to (00)	5

An SDCB shall contain a Previous Session item for each Session preceding the current Session. The SDCB of the first Session shall not contain a Previous Session item. The Previous Session items shall be ordered with increasing addresses.

Previous Session item bytes B₀ to B₂ – Previous Session item descriptor

these 3 bytes identify the item type and shall be set to (505253), representing the characters “PRS”.

Previous Session item byte B₃ – Reserved

this byte is reserved and shall be set to (00).

Previous Session item byte B₄ – Previous Session number

this byte shall specify the sequence number of the Previous Session specified in this item.

Previous Session item bytes B₅ to B₇ – Previous Session start address

these 3 bytes shall specify the PSN of the first Physical Sector in the Data Zone of the Previous Session specified in this item.

Previous Session item bytes B₈ to B₁₀ – Previous Session end address

these 3 bytes shall specify the PSN of the last Physical Sector in the Data Zone of the Previous Session specified in this item.

Previous Session item bytes B₁₁ to B₁₅ – Reserved

these 5 bytes are reserved and shall be set to (00).

Section 5 – Characteristics of the groove

26 General

All recordings shall occur only in grooved areas. The groove centreline is deviated from the average track centreline with a phase modulated sine-wave. Physical addressing information can be decoded from this phase modulated wobble.

The format of the groove information on the disk is defined in 14.4. Clause 28 specifies the requirements for the signals from grooves, as obtained when using the Reference Drive as defined in Clause 9.

27 Method of testing

27.1 Environment

All signals in Clause 28 shall be within their specified ranges with the disk in the test environment conditions defined in 8.1.1.

27.2 Reference Drive

All signals specified in Clause 28 shall be measured in the indicated channels of the Reference Drive as defined in Clause 9. The drive shall have the following characteristics for the purpose of these tests.

27.2.1 Optics and mechanics

The focused optical beam shall have the properties defined in 9.2 a) to i). The disk shall rotate as specified in 9.5.

27.2.2 Read power

The optical power incident on the read-out surface of the disk (used for reading the information) shall be $0,7 \text{ mW} \pm 0,1 \text{ mW}$.

27.2.3 Read channels

The drive shall have two read channels. Read Channel 1 gives a signal $(I_1 + I_2)$ related to the total amount of light in the exit pupil of the objective lens. Read Channel 2 gives a signal $(I_1 - I_2)$ related to the difference in the amount of light in the two halves of the exit pupil of the objective lens. These channels can be implemented as given in Clause 9.

For measurement of the push-pull and track cross signals, the read channel signals shall be filtered by a 1st order LPF with a $f_c(-3 \text{ dB})$ of 30 kHz.

For measurement of the wobble signal, the read channel signals shall be filtered by a 1st order Band Pass Filter with frequency range (-3 db): 25 kHz, slope +20 dB/decade to 4,0 MHz, slope -20 dB/decade.

27.2.4 Tracking

During the measurement of the signals, the axial tracking error between the focus of the optical beam and the recording layer shall not exceed

$$e_{\max}(\text{axial}) = 0,20 \text{ } \mu\text{m}$$

and the radial tracking error between the focus of the optical beam and the centre of a track shall not exceed

$$e_{\max}(\text{radial}) = 0,022 \text{ } \mu\text{m}$$

27.3 Definition of signals

All signals are linearly related to currents through a photo detector, and are therefore linearly related to the optical power falling on the detector.

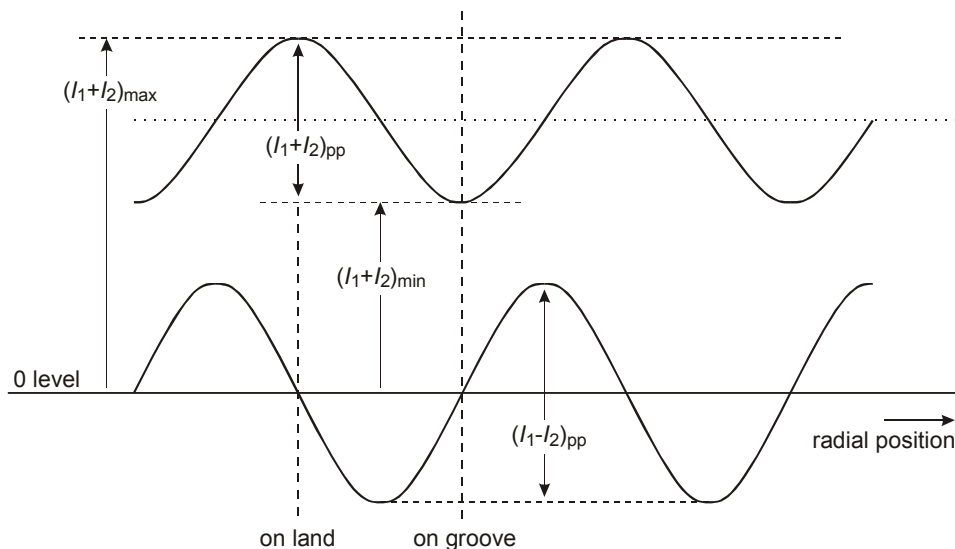

Figure 30 - Signals from grooves in the Read Channels when crossing the tracks

Push-pull signal

The push-pull signal is the filtered sinusoidal difference signal $(I_1 - I_2)$ in Read Channel 2, when the focus of the optical beam crosses the tracks. The signal can be used by the drive for radial tracking.

Track cross signal

The track cross signal is the filtered sinusoidal sum signal $(I_1 + I_2)$ in Read Channel 1, when the focus of the optical beam crosses the tracks.

Wobble signal

The wobble signal I_W is the filtered sinusoidal difference signal $(I_1 - I_2)$ in Read Channel 2, while the drive meets the minimum tracking requirement.

28 Characteristics of the groove signals

28.1 Phase depth

The phase depth of the groove shall not exceed 90°.

28.2 Push-pull signal

The peak-to-peak value of the push-pull signal PP shall meet the following requirements:

a) before recording:
$$0,30 \leq \frac{(l_1 - l_2)_{pp}}{[(l_1 + l_2)_{max} + (l_1 + l_2)_{min}]/2} \leq 0,60$$

The maximum variation of the push-pull signal before recording shall be:
$$\frac{PP_{max} - PP_{min}}{PP_{max} + PP_{min}} < 0,15$$

b) after recording:
$$0,40 \leq \frac{(l_1 - l_2)_{pp}}{[(l_1 + l_2)_{max} + (l_1 + l_2)_{min}]/2} \leq 0,80$$

c) Ratio of push-pull signal of unrecorded groove to push-pull signal of recorded groove shall be in the range of
$$0,6 \leq \frac{PP_{before}}{PP_{after}} \leq 1,0$$

28.3 Track Cross signal

The Track Cross signal for the unrecorded disk shall meet the following requirement:

The $(l_1 + l_2)_{min}$ value shall be generated at the groove centre.

28.4 Normalized wobble signal

The deviation from the track centreline shall be measured by the normalized wobble signal. The amount of distance that the centre of the wobble groove deviates from the average track centreline can be calculated according to Annex M.

The wobble signal shall be measured in an empty track during the monotone wobble part, at locations where the amplitude is not enhanced due to the positive interference of the wobble from adjacent tracks.

The normalized wobble signal shall be

$$0,15 \leq \frac{l_{W,pp-min}}{(l_1 - l_2)_{pp}} \leq 0,25$$

At locations where the amplitude of the wobble signal is enhanced due to the positive interference of the wobble from adjacent tracks, the maximum wobble signal shall be

$$\frac{l_{W,pp-max}}{l_{W,pp-min}} \leq 2,6$$

28.5 Characteristics of the wobble

The average Narrow band SNR of the wobble signal before recording shall be greater than 45 dB. The measurement shall be made using a resolution bandwidth of 1 kHz.

The average Narrow band SNR of the wobble signal after recording shall be greater than 38 dB. The measurement shall be made using a resolution bandwidth of 1 kHz.

Section 6 - Characteristics of the recording layer

29 Method of testing

The format of the information on the disk is defined in Clause 13. Clause 30 specifies the requirements for the signals from recorded grooves, as obtained when using the Reference Drive as defined in Clause 9.

This Clause specifies the average quality of the recorded information. Local deviations from the specified values, called defects, can cause tracking errors or errors in the Data fields. These errors are covered by Clause 32 and Section 7.

29.1 Environment

All signals in 30.2.2 to 30.2.6 shall be within their specified ranges with the disk in the test environment conditions defined in 8.1.1.

29.2 Reference Drive

All signals specified in 30.2.2 to 30.2.6 shall be measured in the indicated channels of the Reference Drive as defined in Clause 9. The drive shall have the following characteristics for the purpose of these tests.

29.2.1 Optics and mechanics

The focused optical beam shall have the properties defined in 9.2 a) to i). The disk shall rotate as specified in 9.5.

29.2.2 Read power

The optical power incident on the read-out surface of the disk (used for reading the information) shall be $0,7 \text{ mW} \pm 0,1 \text{ mW}$.

29.2.3 Read channels

The drive shall have two read channels. Read Channel 1 gives a signal ($I_1 + I_2$) related to the total amount of light in the exit pupil of the objective lens. Read Channel 2 gives a signal ($I_1 - I_2$) related to the difference in the amount of light in the two halves of the exit pupil of the objective lens. These channels can be implemented as given in Clause 9.

For measurement of the push-pull and track cross signals, the read channel signals shall be filtered by a 1st order LPF with a $f_c(-3 \text{ dB})$ of 30 kHz.

The signal from Read channel 1 is not equalized except when measuring jitter. The threshold level for binarizing the read signal shall be controlled to minimize the effects of mark and space size changes due to parameter variations during writing. Jitter measurements shall be made using the Read Channel 1 with the characteristics in Annex D.

29.2.4 Tracking

During recording and during the measurement of the signals, the axial tracking error between the focus of the optical beam and the recording layer shall not exceed

$$e_{\max}(\text{axial}) = 0,20 \text{ } \mu\text{m}$$

and the radial tracking error between the focus of the optical beam and the centre of a track shall not exceed

$$e_{\max}(\text{radial}) = 0,022 \text{ } \mu\text{m}.$$

NOTE

At high recording or playback velocities, advanced servo systems might be needed to achieve tracking errors below these maximum values.

29.2.5 Scanning velocity

All write tests are performed at the velocities of the disk defined in 14.4.2.

The disk shall be tested at all Primary and Upper speeds with the related write strategy.

All read tests are performed at the Reference velocity.

29.3 Write conditions

Marks and spaces are written on the disk by pulsing a laser.

29.3.1 Write pulse waveform

The laser power is modulated according to one of the write pulse waveforms given in Annex F.

A 3T to 14T mark is written by applying a multiple-pulse train of short write pulses or by applying a single write pulse.

The recording power has two basic levels: the Write power (P_w) and the Bias power (P_b), which are the optical powers incident at the entrance surface of the disk and used for writing marks and spaces.

In case of the single write pulse a power enhancement dP_w can be applied on the 3T and 4T pulses; furthermore for optimum cooling of the recording layer after writing a mark, the power shall be switched to the lowest possible level (P_c) for some time immediately following the write pulse (see Annex F.2).

The value of the P_w power level shall be optimized according to Annex H.

The actual P_w power level shall be within 5 % of its optimum value.

29.3.2 Write power

The optimized write powers, P_{wo} and P_{bo} shall meet the following conditions.

$P_{peak} = P_{wo}$ in case no power enhancement is applied and

$P_{peak} = P_{wo} + dP_{wo}(cm=3)$ or $P_{wo} + dP_{wo}(cm=4)$ whichever is the largest in case power enhancement is applied.

for the basic write strategy defined in 14.4.2.2 (see also 12.3):

$$P_{peak} \leq 15,0 \text{ mW for } 650 \text{ nm} \leq \lambda \leq \lambda_{IND}$$

$$P_{peak} \leq 19,0 \text{ mW for } \lambda_{IND} < \lambda \leq 665 \text{ nm}$$

for the "4x+" write strategy defined in 14.4.2.3.1 (see also 12.3):

$$P_{peak} \leq 19,0 \text{ mW for } 650 \text{ nm} \leq \lambda \leq \lambda_{IND}$$

$$P_{peak} \leq 22,0 \text{ mW for } \lambda_{IND} < \lambda \leq 665 \text{ nm}$$

$$P_{wo} \geq 6 \text{ mW at } \lambda = \lambda_{IND}$$

$$P_{bo} = 0,7 \pm 0,1 \text{ mW}$$

$$P_{co} < 0,1 \text{ mW}$$

29.3.3 Write power dependency on wavelength

The change of the optimum write power P_{wo} induced by a change of the laser wavelength (see Annex J) shall meet the following condition

$$0 \leq (dP_{wo}/d\lambda)/(P_{IND}/\lambda_{IND}) \leq 25 \quad (dP_{wo}/d\lambda \text{ averaged over the wavelength range from } 645 \text{ nm to } 670 \text{ nm})$$

29.3.3 Write power window

To allow for some variations in the write power of practical drive implementations, the normalized write power windows (NWPW) shall have a minimum width. The normalized write power windows shall be determined in the following way:

- the jitter is measured as a function of the write power P_w at the inner diameter of the Data Zone and at the outer diameter of the Data Zone; in general those two curves will not coincide (see Figure 31),
- the single write power window is defined as the power range ($P_{upper,n} - P_{lower,n}$) where the jitter curve concerned is below 9 % (see Figure 31),

the requirement for each normalized single write power window is:

$$NWPW_S = \frac{P_{upper,n} - P_{lower,n}}{(P_{upper,n} + P_{lower,n})/2} \geq 0,12$$

- the net write power window is defined as the power range where both jitter curves are below 9 % (see example in Figure 31, where the net power window = $P_{upper,1} - P_{lower,2}$), the requirement for the normalized net write power window is:

$$NWPW_N = \frac{P_{upper,m} - P_{lower,n}}{(P_{upper,m} + P_{lower,n})/2} \geq 0,10 ,$$

in which $P_{upper,m}$ is the highest power at which both jitter curves are below 9 % and $P_{lower,n}$ is the lowest power at which both jitter curves are below 9 %

- the above requirements shall be fulfilled at all defined recording velocities.

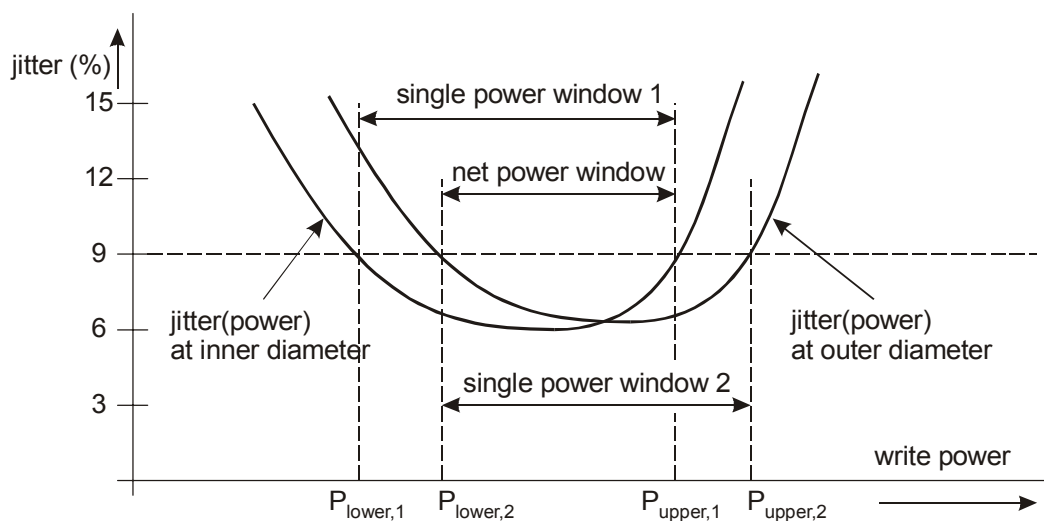

Figure 31 - Example of the write power windows

NOTE

Above procedures are based on typical disks which show a monotonic shift of the power window as function of the radius. If this is not the case, power windows shall be measured at several radii and the net power window shall be defined as the power range where all jitter curves are below 9 %.

29.4 Measurement conditions

The test for jitter shall be carried out on any group of five adjacent tracks, designated $(m-2)$, $(m-1)$, m , $(m+1)$, $(m+2)$, in the Information Zone of the disk. The jitter shall be measured on recordings made at all velocities specified in 14.4.2.2, byte 32 and 33 and in the Extended Information blocks defined under 14.4.2.3.

For measurement of jitter, the system described in Annex D shall be used.

The Jitter shall be measured according to the following procedure:

Write random data on all five tracks as specified in 29.3.1.

Read the data of track m under the conditions specified in 29.2.

30 Characteristics of the recorded signals

The following signals shall be measured, after recording with the write conditions as specified in 29.3.1.

30.1 Channel bit length

The average Channel bit length over each RUN shall be

$$133,3 \text{ nm} \pm 1,4 \text{ nm}$$

30.2 Definition of signals

All signals are linearly related to currents through a photo-diode detector, and are therefore linearly related to the optical power falling on the detector.

30.2.1 High frequency signals (HF)

The HF signal is obtained by summing the currents of the four elements of the photo detector as generated in Read Channel 1. These currents are modulated by the effects of the marks and spaces representing the information on the recording layer.

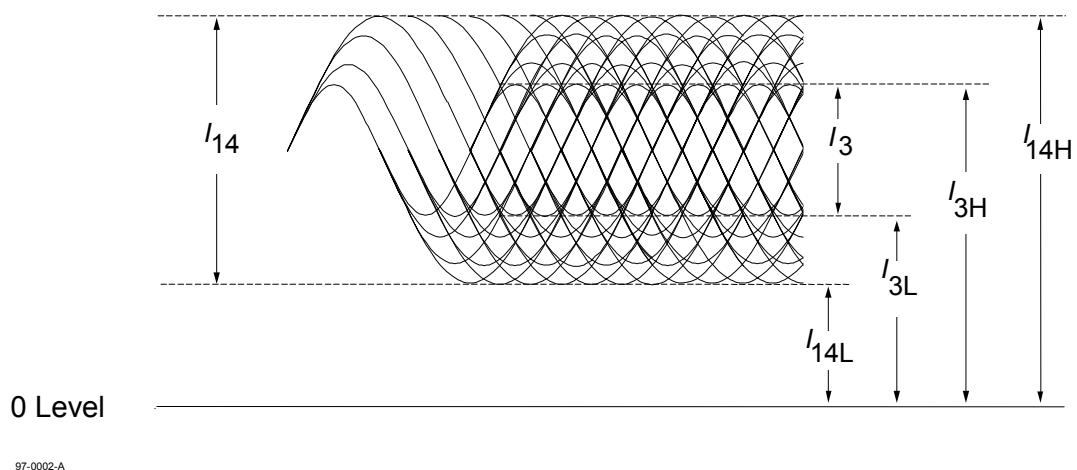

Figure 32 - Signals from spaces and marks in Read channel 1

30.2.2 Modulated amplitude

The modulated amplitude I_{14} is the peak-to-peak value of the HF signal generated by the largest mark and space lengths (see Figure 32). The peak value I_{14H} shall be the peak value of the HF signal before a.c. coupling. The modulated amplitude I_3 is the peak-to-peak value generated by the shortest mark and space lengths. The 0 Level is the signal level obtained from the measuring device when no disk is inserted. These parameters shall meet the following requirements under all conditions, also such as when recordings have been made at different speeds.

$$\frac{I_{14}}{I_{14H}} \geq 0,60$$

$$\frac{I_3}{I_{14}} \geq 0,15$$

$$\text{Within one disk, } \frac{(I_{14H\max} - I_{14H\min})}{I_{14H\max}} \leq 0,25$$

$$\text{Within one revolution, } \frac{(I_{14H\max} - I_{14H\min})}{I_{14H\max}} \leq 0,15$$

30.2.3 Signal asymmetry

The signal asymmetry shall meet the following requirement:

$$-0,05 \leq \left[\frac{\frac{I_{14H} + I_{14L}}{2} - \frac{I_{3H} + I_{3L}}{2}}{I_{14}} \right] \leq +0,15$$

30.2.4 Normalized Slicing Level jump

Between any 2 consecutive ECC Blocks, the Normalized Slicing Level (NSL) jump shall be:

$$\left| \frac{(I_{3H,2} + I_{3L,2}) - (I_{3H,1} + I_{3L,1})}{(I_{3H,2} - I_{3L,2}) + (I_{3H,1} - I_{3L,1})} \right| \leq 0,35$$

where $I_{3H,1}$ and $I_{3L,1}$ are the I_3 levels just before the linking position and $I_{3H,2}$ and $I_{3L,2}$ are the I_3 levels just after the linking position.

This requirement shall be fulfilled also when the 2 ECC Blocks have been recorded at different speeds.

30.2.5 Jitter

Jitter is the standard deviation σ of the time variations of the binary read signal. This binary read signal is created by a slicer, after feeding the HF signal from the HF read channel through an equalizer and LPF (see Annex D). The jitter of the leading and trailing edges is measured relative to the PLL clock and normalized by the Channel bit clock period.

The jitter shall be measured at the Reference velocity using the circuit specified in Annex D.

The jitter measurement shall be using the conditions specified in 29.4.

The measured jitter shall not exceed 9,0 %.

30.2.6 Track Cross signal

The Track Cross signal is the filtered sinusoidal sum signal ($I_1 + I_2$) in Read Channel 1 when the focus of the optical beam crosses the tracks. The Track Cross signal shall meet the following requirement:

$$\frac{(I_1 + I_2)_{pp}}{(I_1 + I_2)_{max}} \geq 0,13$$

30.3 Read stability

When read with a read power of 0,8 mW at a temperature of 55 °C, all parameters specified in 30.2.2 to 30.2.6 shall be within their specified ranges after 1 000 000 repeated reads.

NOTE

Reading with the same read power at lower speeds than the reference speed might degrade the read stability.

31 Additional testing conditions

Recorded +R disks compliant with this +R Ecma Standard shall also fulfil the following basic signal specifications when measured with the Pick Up Head according to the ECMA-267 Standard.

31.1 Test environment

All conditions are the same as in 29.1 to 29.2.5 except for the following.

31.1.1 Optics

The focused optical beam used for reading data shall have the following properties:

- | | |
|--|--|
| a) Wavelength (λ) | 650 nm \pm 5 nm |
| b) Numerical aperture of the objective lens (NA) | 0,60 \pm 0,01 |
| c) The objective lens shall be compensated for spherical aberrations caused by a parallel substrate with nominal thickness (0,6 mm) and nominal refractive index (1,55). | |
| d) Wave front aberration | 0,033 \times λ rms max. |
| e) Light intensity at the rim of the pupil of the objective lens | 60 % to 70 % of the maximum intensity in the radial direction and over 90 % in the tangential direction. |
| f) Polarization of the light | Circular |
| g) Read power | 0,7 mW \pm 0,1 mW |
| h) Relative Intensity Noise (RIN)* of laser diode | -134 dB/Hz max. |
- *RIN (dB/Hz) = 10 log [(a.c. light power density / Hz) / d.c. light power]

31.2 Definition of signals

For the definition of the following signals see 30.2 and the underlying subclauses.

31.2.1 Modulated amplitude

$$I_{14} / I_{14H} \geq 0,60$$

$$I_3 / I_{14} \geq 0,15$$

$$\text{Within one disk, } (I_{14Hmax} - I_{14Hmin}) / I_{14Hmax} \leq 0,33 \text{ (with PBS)}$$

$$\text{Within one disk, } (I_{14Hmax} - I_{14Hmin}) / I_{14Hmax} \leq 0,20 \text{ (without PBS)}$$

$$\text{Within one revolution, } (I_{14Hmax} - I_{14Hmin}) / I_{14Hmax} \leq 0,15 \text{ (with PBS)}$$

$$\text{Within one revolution, } (I_{14Hmax} - I_{14Hmin}) / I_{14Hmax} \leq 0,10 \text{ (without PBS)}$$

31.2.2 Signal asymmetry

$$-0,05 \leq \left[\frac{I_{14H} + I_{14L} - I_{3H} + I_{3L}}{2} \right] / I_{14} \leq +0,15$$

31.2.3 Jitter

The jitter shall be measured at the Reference velocity using the circuit specified in Annex D. The jitter measurement shall be using the conditions specified in 29.4. The measured jitter shall not exceed 9,0 %.

31.2.4 Track Cross signal

$$\frac{(I_1 + I_2)_{pp}}{(I_1 + I_2)_{max}} \geq 0,10$$

31.2.5 Differential phase tracking error signal

The output currents of the four quadrants of the split photo detector shown in Figure 33 are identified by I_a , I_b , I_c , and I_d .

The differential phase tracking error signal shall be derived from the phase differences between the sum of the currents of diagonal pairs of photo detector elements when the light beam crosses the tracks:

{Phase ($I_a + I_c$) - Phase($I_b + I_d$)}, see Figure 34 and Annex E.

The phase difference signals shall be low-pass filtered with f_c (-3 db) of 30 kHz.

This differential phase tracking error signal shall meet the following requirements (see Figure 34):

Amplitude

At the positive 0 crossing $\overline{\Delta t}/T$ shall be in the range 0,5 to 1,1 at 0,10 μm radial offset, where $\overline{\Delta t}$ is the average time difference derived from the phase differences between the sum of the currents of diagonal pairs of photo detector elements, and T is the Channel bit clock period.

Asymmetry (see Figure 34)

The asymmetry shall meet the following requirement:

$$\frac{|T_1 - T_2|}{|T_1 + T_2|} \leq 0,2 \quad \text{where } T_1 \text{ is the positive peak value of } \overline{\Delta t}/T$$

and T_2 is the negative peak value of $\overline{\Delta t}/T$

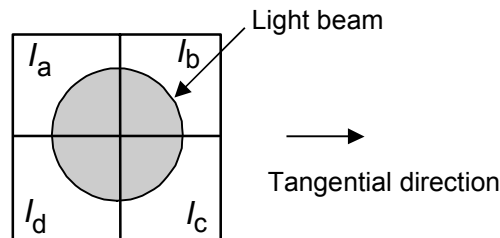

97-0047-A

Figure 33 - Quadrant photo detector

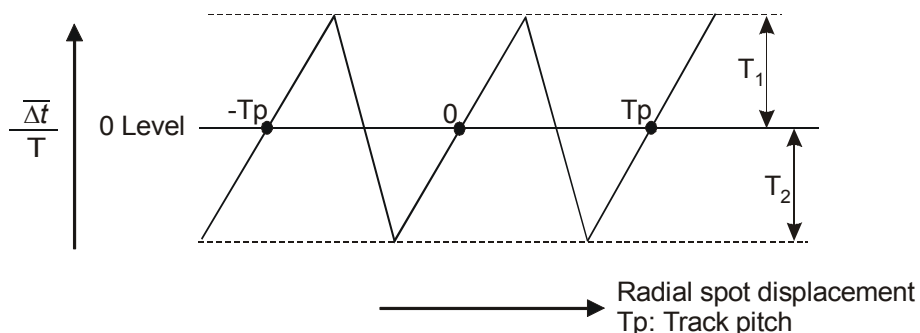

Figure 34 - Differential phase tracking error signal

31.2.6 Tangential push-pull signal

This signal shall be derived from the instantaneous level of the differential output $(I_a + I_d) - (I_b + I_c)$. It shall meet the following requirements, see Figure 35:

$$0 \leq \frac{[(I_a + I_d) - (I_b + I_c)]_{pp}}{I_{14}} \leq 0,9$$

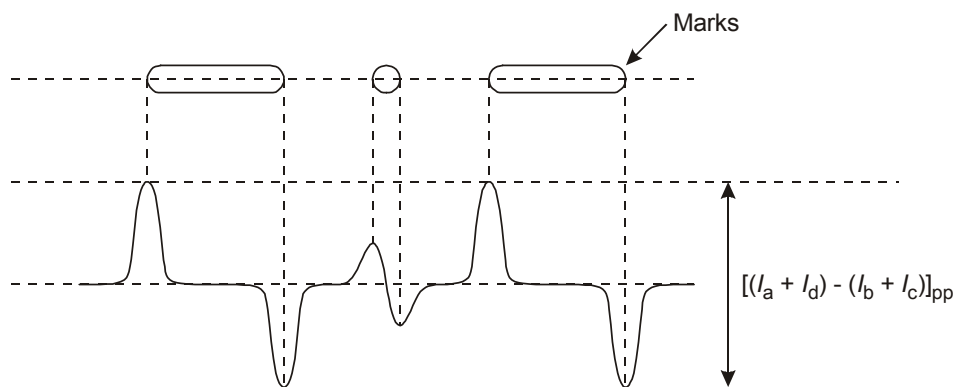

Figure 35 – Tangential push-pull signal

32 Quality of the recording layer

For the integrity of the data on the disk, the recording layer shall fulfil the following initial quality requirements.

32.1 Defects

Defects are air bubbles and black spots. Their diameter shall meet the following requirements:

- for air bubbles it shall not exceed 100 μm ,
- for black spots causing birefringence it shall not exceed 200 μm ,
- for black spots not causing birefringence it shall not exceed 300 μm .

In addition, over a distance of 80 mm in scanning direction of tracks, the following requirements shall be met:

- the total length of defects larger than 30 μm shall not exceed 300 μm ,
- there shall be at most 6 such defects.

32.2 Data errors

A byte error occurs when one or more bits in a byte have a wrong value, as compared to their original recorded value.

A row of an ECC Block as defined in 13.3 that has at least 1 byte in error constitutes a PI error.

If a row of an ECC Block as defined in 13.3 contains more than 5 erroneous bytes, the row is said to be “PI-uncorrectable”.

The disk shall be recorded with arbitrary data in one single uninterrupted writing action from the start of the Lead-in Zone until the end of the Lead-out Zone (“Disk-At-Once” mode).

During playback after the initial recording, the errors as detected by the error correction system shall meet the following requirements:

- in any 8 consecutive ECC Blocks the total number of PI errors before correction shall not exceed 280,
- in any ECC Block the number of PI-uncorrectable rows should not exceed 4.

Section 7 - Characteristics of user data

33 Method of testing

Clause 34 describes a series of measurements to test conformance of the user data on the disk with this Ecma Standard. It checks the legibility of the user-written data. The data is assumed to be arbitrary. The data may have been written by any drive in any operating environment (see 8.1.2). The read tests shall be performed on the Reference Drive as defined in Clause 9.

Whereas Clause 29 disregards defects, Clause 34 includes them as an unavoidable deterioration of the read signals. The severity of a defect is determined by the correctability of the ensuing errors by the error detection and correction circuit in the read channel defined below. The requirements in Clause 34 define a minimum quality of the data, necessary for data interchange.

33.1 Environment

All signals in 34.1 to 34.2 shall be within their specified ranges with the disk in any environment in the range of allowed operating environments defined in 8.1.2. It is recommended that before testing, the entrance surface of the disk shall be cleaned according to the instructions of the manufacturer of the disk.

33.2 Reference Drive

All signals specified in Clause 34 shall be measured in the indicated channels of the Reference Drive as defined in Clause 9. The drive shall have the following characteristics for the purpose of these tests:

33.2.1 Optics and mechanics

The focused optical beam shall have the properties already defined in 9.2 a) to i). The disk shall rotate as specified in 9.5.

33.2.2 Read power

The optical power incident on the entrance surface of the disk (used for reading the information) shall be $0,7 \text{ mW} \pm 0,1 \text{ mW}$.

33.2.3 Read channels

The drive shall have two read channels. Read Channel 1 gives a signal $(I_1 + I_2)$ related to the total amount of light in the exit pupil of the objective lens. Read Channel 2 gives a signal $(I_1 - I_2)$ related to the difference in the amount of light in the two halves of the exit pupil of the objective lens. These channels can be implemented as given in 9.3 and 9.6.

The signal from Read channel 1 is equalized and filtered before processing. The threshold level for binarizing the read signal shall be controlled to minimize the effects of mark and space size changes due to parameter variations during writing. For measurement of the disk quality as specified in Clause 34, the equalizer, filter and slicer, and the characteristics of the PLL shall be the same as specified in Annex D for the jitter measurement.

33.2.4 Error correction

Correction of errors in the data bytes shall be carried out by an error detection and correction system based on the definition in 13.3.

33.2.5 Tracking

During the measurement of the signals, the axial tracking error between the focus of the optical beam and the recording layer shall not exceed

$$e_{\max}(\text{axial}) = 0,20 \text{ } \mu\text{m}$$

and the radial tracking error between the focus of the optical beam and the centre of a track shall not exceed

$$e_{\max}(\text{radial}) = 0,022 \text{ } \mu\text{m}$$

34 Minimum quality of a Recording Unit

This Clause specifies the minimum quality of the data of a Recording Unit as required for data interchange. The quality shall be measured on the Reference Drive as defined in Clause 9 and Annex D.

A byte error occurs when one or more bits in a byte have a wrong value, as detected by the ECC and/or EDC circuits.

34.1 Tracking

The focus of the optical beam shall not jump tracks unintentionally.

34.2 User-written data

The user-written data in a Recording Unit as read in Read channel 1 shall not contain any byte errors that cannot be corrected by the error correction defined in 13.3.

Annex A (normative)

80 mm +R disk

The +R System also allows an 80 mm disk with capacities of 1,46 Gbytes and 2,92 Gbytes. All mechanical, physical and optical characteristics shall be equal to those of the 120 mm disks specified in this document, except for the following items:

see: **10.2 Overall dimensions**

The disk shall have an overall diameter $d_1 = 80,00 \text{ mm} \pm 0,30 \text{ mm}$

see: **10.7 Information Zone**

The Information Zone shall extend from diameter d_6 to diameter

$$d_7 = 77,5 \text{ mm min.}$$

This Zone consists of the Lead-in Zone, the Data Zone, the Lead-out Zone and the Inner and Outer Drive Areas (see also Clause 15).

see: **11.1 Mass**

The mass of the disk shall be in the range of 6,0 g to 9,0 g.

see: **11.2 Moment of inertia**

The moment of inertia of the disk, relative to its rotation axis, shall not exceed $0,010 \text{ g}\cdot\text{m}^2$.

see: **11.3 Dynamic imbalance**

The dynamic imbalance of the disk, relative to its rotation axis, shall not exceed $1,5 \text{ g}\cdot\text{mm}$.

see: **14.1 Track shape**

The tracks shall be continuous in the Information Zone. The groove tracks shall start at a radius of $22,0 \text{ mm max.}$ and end at a radius of $38,75 \text{ mm min.}$

see: **14.4.1.1 ADIP word structure, bit 2 to 23**

Physical Address (0379CC), which is the first address corresponding to the Lead-out Zone, shall be located at a radius $\leq 38,0 \text{ mm}$.

see: **14.4.2.1 General information - Bytes 0 to 31**

Byte 1 – Disk size and maximum transfer rate

Bits b_7 to b_4 shall specify the disk size, they shall be set to 0001, indicating a 80 mm disk

Bytes 4 to 15 – Data Zone allocation

Bytes 9 to 11 shall be set to (0DE72F) to specify PSN 911 151 as the last possible Physical Sector of the Data Zone.

see: **16** **Layout of the Information Zone of a Single-session disk**

Table 6 - Layout of a fully recorded Single-session disk (see also Annex A)

	Description	Nominal radius in mm	PSN of the first Physical Sector	Number of Physical Sectors
<u>Inner Drive Area</u>	all the same as 120 mm disk	---	---	---
<u>Lead-in</u>	all the same as 120 mm disk	---	---	---
<u>Data</u>	Data Zone	start 24,000 mm	(030000)	714 544 max
<u>Lead-out</u>	Buffer Zone 3	start 38,000 mm (at full capacity)	(0DE730) max	768
	Outer Disk Identification Zone		(0DEA30) max	256
	Guard Zone 2		(0DEB30) max	4 096 min
<u>Outer Drive Area</u>	Outer Disk Administration Zone	start 38,082 mm	(0DFB30)	4096
	Outer Disk Count Zone	start 38,147 mm	(0E0B30)	4096
	Outer Disk Test Zone	start 38,212 mm	(0E1B30)	16 384
	Guard Zone 3	start 38,472 mm end ≥ 38,500 mm	(0E5B30)	blank

see: **18.8.1** **Physical format information**

Bytes 4 to 15 – Data Zone allocation

Bytes 9 to 11 on a finalized Single Session disk (see 23.3):

shall specify the Sector Number of the last Physical Sector of the Data Zone.

on a Multi-session disk (see Clause 22):

shall be set to (0DE72F) to specify PSN 911 151 as the last possible Physical Sector on the disk for the storage of User Data.

see: **19** **Data Zone**

714 544 Physical Sectors for the storage of user data area.

The start radius of the Data Zone is determined by the location of ADIP Physical Address (00C000) and the maximum end radius is determined by the location of ADIP Physical Address (0379CC) (see 14.4.1.1, bit 2 to 23 and 13.7.1).

see: **20** **Lead-out Zone**

		Data Zone		
---			---	
Physical Sector 911 152		Buffer Zone 3	Physical Sector (0DE730)	
Physical Sector 911 919		768 Physical Sectors	Physical Sector (0DEA2F)	
Physical Sector 911 920		with Main Data set to (00)	Physical Sector (0DEA30)	
		Outer Disk Identification Zone		
		256 Physical Sectors		
Physical Sector 912 175		Guard Zone 2	Physical Sector (0DEB2F)	
Physical Sector 912 176		min 4 096 Physical Sectors	Physical Sector (0DEB30)	
		with Main Data set to (00)		
Physical Sector 916 271		Outer Drive Area	Physical Sector (0DFB2F)	

Figure 27 - Lead-out Zone

see: **20.1** **Buffer Zone 3**

The last possible start location of Buffer Zone 3 is (0DE730).

see: **21** **Outer Drive Area**

		Lead-out Zone		
Physical Sector 916 272		Outer Disk Administration Zone	Physical Sector (0DFB30)	
Physical Sector 920 367		4 096 Physical Sectors	Physical Sector (0E0B2F)	
Physical Sector 920 368		Outer Disk Count Zone	Physical Sector (0E0B30)	
		4 096 Physical Sectors		
Physical Sector 924 463		Outer Disk Test Zone	Physical Sector (0E1B2F)	
Physical Sector 924 464		16 384 Physical Sectors	Physical Sector (0E1B30)	
Physical Sector 940 847		Guard Zone 3	Physical Sector (0E5B2F)	
Physical Sector 940 848		Blank	Physical Sector (0E5B30)	

Figure 28 – Outer Drive Area

see: **21.2** **Outer Disk Count Zone**

The relation between the first Physical Sector number PSN_{ODT} of the used ECC Block in the Outer Disk Test Zone and the Physical Sector numbers PSN_{ODC} to $PSN_{ODC} + 3$ of the 4 Physical Sectors in the Outer Disk Count Zone is determined by the following mathematical expression:

$$PSN_{ODC} = \{(PSN_{ODT}) - (0E1B30)\} / (04) + (0E0B30)$$



Annex B (normative)

Measurement of light reflectivity

B.1 Calibration method

The reflectivity of a disk can be measured in several ways. The two most common methods are:

- parallel method,
- focused method.

For use in players the focused method with the help of a reference disk with known reflectivity is the most relevant and easiest one, while for the calibration of the reference disk the parallel method is easier.

When measuring the reflectivity in the focused way, only the light returned by the reflective layer of the disk (R_m) will fall onto the photo detector. The reflected light coming from the front surface of the disk and the light coming from the parasitic reflectance's inside the disk will mainly fall outside the photo detector. Because in the parallel method only the "total" reflectance ($R_{//}$) can be measured, a calculation is needed to determine the "main" reflectance from the reflective layer.

A good reference disk shall be chosen, for instance 0,6 mm glass disk with a golden reflective mirror. This reference disk shall be measured by a parallel beam as shown in Figure B.1

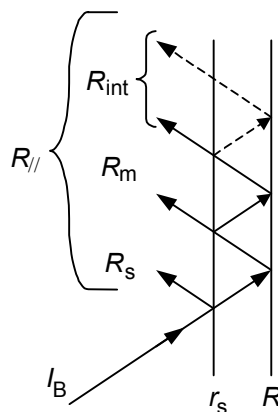

Figure B.1 - Reflectivity calibration

In this Figure the following applies:

R = reflectivity of the recording layer (including the double pass substrate transmission)

r_s = reflectivity of the entrance surface

R_{ref} = reflectivity as measured by the focussed beam (is by definition = R_m / I_B)

I_B = incident beam

R_s = reflectance caused by the reflectivity of the entrance surface

R_m = main reflectance caused by the reflectivity of the recording layer

R_{int} = reflectance caused by the internal reflectances between the entrance surface and the recording layer

$R_{//}$ = measured value ($R_s + R_m + R_{int}$)

The reflectivity of the entrance surface is defined by:

$$r_s = \left(\frac{n-1}{n+1} \right)^2, \text{ where } n \text{ is the index of refraction of the substrate.}$$

The main reflectance $R_m = R_{//} - R_s - R_{int}$ which leads to:

$$R_{ref} = \frac{R_m}{I_B} = \left[\frac{(1-r_s)^2 \times \left(\frac{R_{//}}{I_B} - r_s \right)}{1-r_s \times \left(2 - \frac{R_{//}}{I_B} \right)} \right]$$

The reference disk shall be measured on a reference drive. The total detector current ($I_1 + I_2$) obtained from the reference disk, and measured by the focused beam is equated to R_m as determined above.

Now the arrangement is calibrated and the focused reflectivity is a linear function of the reflectivity of the recording layer and the double pass substrate transmission, independently from the reflectivity of the entrance surface.

B.2 Measuring method

Reflectivity in the unrecorded Information Zone

A method of measuring the reflectivity using the reference drive.

- (1) Measure the total detector current $(I_1 + I_2)_s$ from the reference disk with calibrated reflectivity R_{ref} .
- (2) Measure the total detector current $(I_1 + I_2)_g$ from a groove track in an area of the disk under investigation where the groove track and the two adjacent tracks on each side of the track to be measured have not been recorded.
- (3) Calculate the unrecorded disk reflectivity R_d as follows

$$R_d = \frac{(I_1 + I_2)_g}{(I_1 + I_2)_s} \times R_{ref}$$

Reflectivity in the recorded Information Zone

A method of measuring the reflectivity using the reference drive.

- (1) Measure the total detector current $(I_1 + I_2)_s$ from the reference disk with calibrated reflectivity R_{ref} .
- (2) Measure I_{14H} from a recorded groove track in an area of the disk under investigation where at least the two adjacent tracks on each side of the track to be measured have been recorded.
- (3) Calculate the recorded disk reflectivity R_{14H} as follows:

$$R_{14H} = \frac{I_{14H}}{(I_1 + I_2)_s} \times R_{ref}$$

Annex C (normative)

Measurement of birefringence

C.1 Principle of the measurement

In order to measure the birefringence, circularly polarized light in a parallel beam is used. The phase retardation is measured by observing the ellipticity of the reflected light.

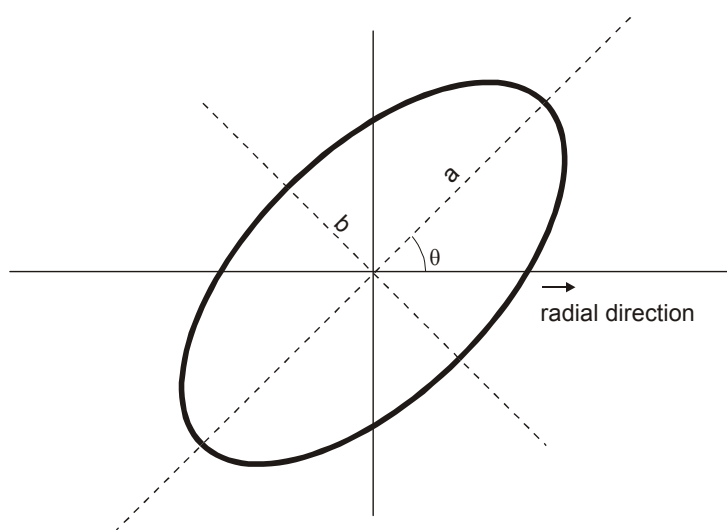

Figure C.1 - Ellipse with ellipticity $e = b/a$ and orientation θ

The orientation θ of the ellipse is determined by the orientation of the optical axis

$$\theta = \gamma - \pi/4 \quad (1)$$

where γ is the angle between the optical axis and the radial direction.

The ellipticity, $e = b/a$, is a function of the phase retardation δ

$$e = \tan \left[\frac{1}{2} \left(\frac{\pi}{2} - \delta \right) \right] \quad (2)$$

When the phase retardation δ is known the birefringence BR can be expressed as a fraction of the wavelength

$$BR = \frac{\lambda}{2\pi} \delta \text{ nm} \quad (3)$$

Thus, by observing the elliptically polarized light reflected from the disk, the birefringence can be measured and the orientation of the optical axis can be assessed as well.

C.2 Measurements conditions

The measurement of the birefringence specified above shall be made under the following conditions.

Mode of measurement in reflection, double pass through the substrate.

Wavelength λ of the laser light	640 nm \pm 15 nm
Beam diameter (FWHM)	1,0 mm \pm 0,2 mm
Angle β of incidence in radial direction relative to the radial plane perpendicular to Reference Plane P	7,0° \pm 0,2°
Disk mounting	horizontally
Rotation	less than 1 Hz
Temperature and relative humidity	as specified in 8.1.1

C.3 Example of a measurement set-up

Whilst this Ecma Standard does not prescribe a specific device for measuring birefringence, the device shown schematically in Figure C.2 as an example, is well suited for this measurement.

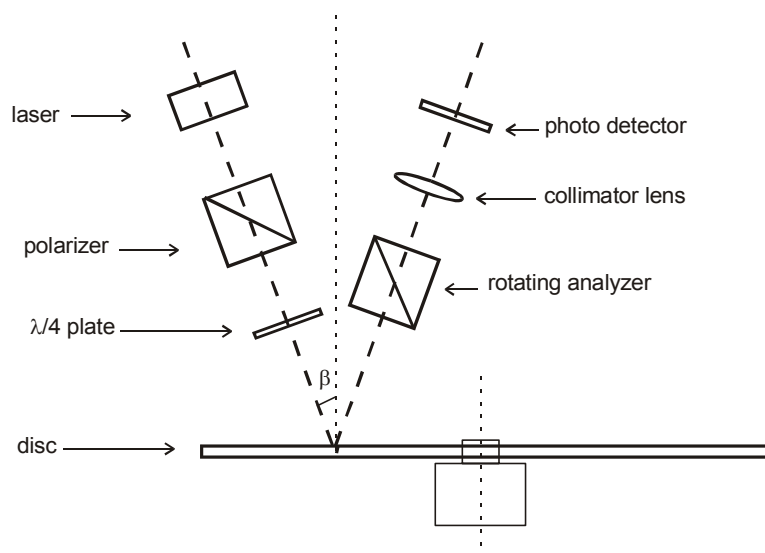

Figure C.2 - Example of a device for the measurement of birefringence

Light from a laser source, collimated into a polarizer (extinction ratio $\approx 10^{-5}$), is made circular by a $\lambda/4$ plate. The ellipticity of the reflected light is analyzed by a rotating analyzer and a photo detector. For every location on the disk, the minimum and the maximum values of the intensity are measured. The ellipticity can then be calculated as

$$e^2 = \frac{I_{\min}}{I_{\max}} \quad (4)$$

Combining equations (2), (3), and (4) yields

$$BR = \frac{\lambda}{4} - \frac{\lambda}{\pi} \arctan \sqrt{\frac{I_{\min}}{I_{\max}}}$$

This device can be easily calibrated as follows

- I_{\min} is set to 0 by measuring a polarizer or a $\lambda/4$ plate,
- $I_{\min} = I_{\max}$ when measuring a mirror

Apart of the d.c. contribution of the front surface reflection, a.c. components may occur, due to the interference of the reflection(s) of the front surface with the reflection(s) from the recording layer. These a.c. reflectivity effects are significant only if the disk substrate has an extremely accurate flatness and if the light source has a high coherence.

Annex D (normative)

Measuring conditions for operation signals

D.1 System diagram for jitter measurement and characterization of user data

The general system diagram shall be as shown in Figure D.1.

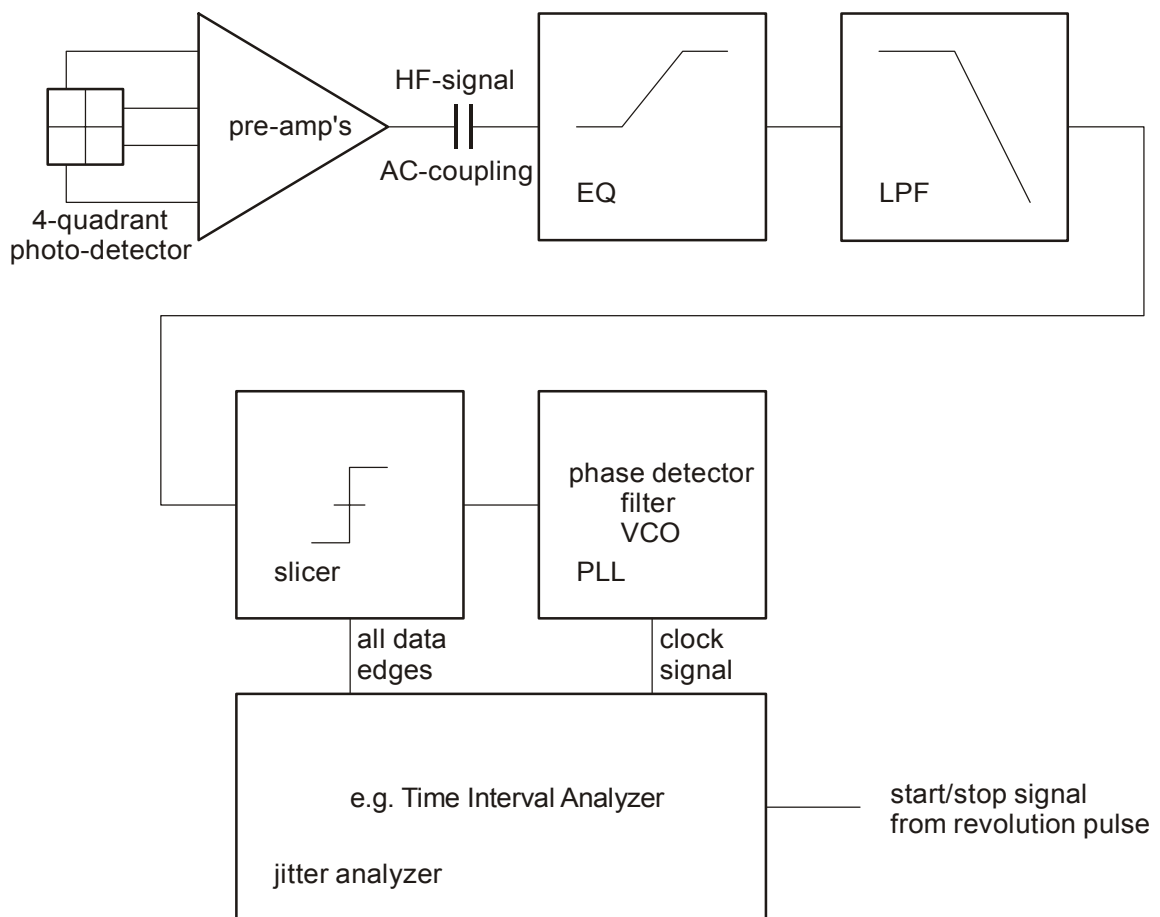

Figure D.1 - General diagram for jitter measurement

D.2 Open loop transfer function for PLL

The open-loop transfer function for the PLL shall be as shown in Figure D.2

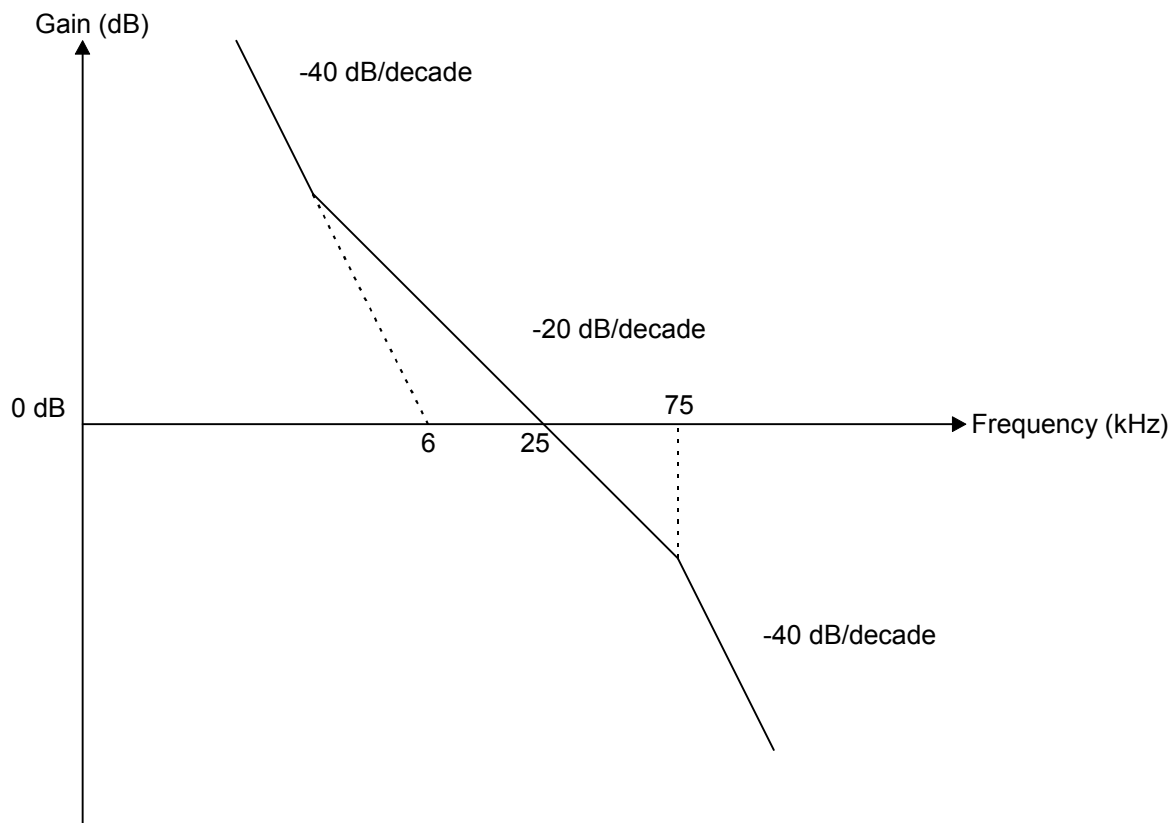

Figure D.2 - Schematic representation of the open-loop transfer function for PLL

D.3 Slicer

The slicer shall be a 1st order, integrating feed-back auto-slicer with a -3 dB closed-loop bandwidth of 5 kHz.

D.4 Conditions for measurement

The bandwidth of the pre-amplifier of the photo detector shall be greater than 20 MHz in order to prevent group-delay distortion.

Equalizer: 3-tap transversal filter with transfer function $H(z) = 1,364 z^{-2} - 0,182 (1 + z^{-4})$

Low-pass filter: 6th order Bessel filter, f_c (-3 dB) = 8,2 MHz

Filtering plus equalization :

- Gain variation : 1 dB max. (below 7 MHz)
- Group delay variation : 1 ns max. (below 7 MHz)
- (Gain at 5,0 MHz - Gain at 0 Hz) : 3,2 dB \pm 0,3 dB

a.c. coupling (high-pass filter) = 1st order, f_c (-3 dB) = 1 kHz

Correction of the angular deviation : only d.c. deviation shall be corrected.

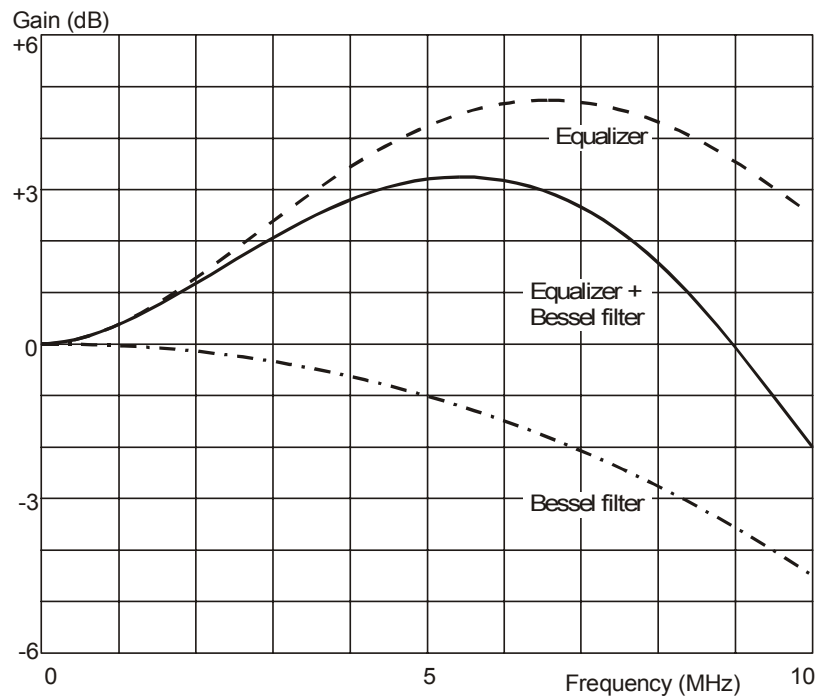

Figure D.3 - Frequency characteristics for the equalizer and the low-pass filter

D.5 Measurement

The jitter of all leading and trailing edges over one revolution shall be measured.



Annex E (normative)

Measurement of the differential phase tracking error

E.1 Measuring method for the differential phase tracking error

The reference circuit for the measurement of the tracking error shall be that shown in Figure E.1. Each output of the diagonal pairs of elements of the quadrant photo detector shall be converted to binary signals independently after equalization of the wave form with the transfer function defined by:

$$H(i\omega) = (1 + 1,6 \times 10^{-7} \times i\omega) / (1 + 4,7 \times 10^{-8} \times i\omega)$$

The gain of the comparators shall be sufficient to reach full saturation on the outputs, even with minimum signal amplitudes. Phases of the binary pulse signal edges (signals B1 and B2) shall be compared to each other to produce a time-lead signal C1 and a time-lag signal C2. The phase comparator shall react to each individual edge with signal C1 or C2, depending on the sign of Δt_i . A tracking error signal shall be produced by smoothing the C1, C2 signals with low-pass filters and by subtracting by means of a unity gain differential amplifier. The low-pass filters shall be 1st order filters with a cut-off frequency (-3 dB) of 30 kHz.

Special attention shall be given to the implementation of the circuit because very small time differences have to be measured (1 % of T equals only 0.38 ns). Careful averaging is needed.

The average time difference between two signals from the diagonal pairs of elements of the quadrant detector shall be

$$\overline{\Delta t} = \frac{1}{N} \sum \Delta t_i$$

where N is the number of edges, both rising and falling.

E.2 Measurement of $\overline{\Delta t}/T$ without time interval analyzer

The relative time difference $\overline{\Delta t}/T$ is represented by the amplitude of the tracking error signal provided that the amplitudes of the C1 and C2 signals and the frequency component of the read-out signals are normalized. The relation between the tracking error amplitude $\overline{\Delta TVE}$ and the time difference is given by:

$$\overline{\Delta TVE} = \frac{\sum \Delta t_i}{\sum T_i} V_{pc} = \frac{\sum \Delta t_i}{NnT} V_{pc} = \frac{\overline{\Delta t}}{T} \times \frac{V_{pc}}{n}$$

where:

V_{pc} is the amplitude of the C1 and C2 signals

T_i is the actual length of the read-out signal in the range 3T to 14T

$n.T$ is the weighted average value of the actual lengths

$N.n.T$ is the total averaging time.

The specification for the tracking gain can now be rewritten by using the tracking error amplitude as follows:

$$0.5 \times \left(\frac{V_{pc}}{n} \right) \leq \overline{\Delta TVE} \leq 1.1 \times \left(\frac{V_{pc}}{n} \right) \text{ at } 0.1 \mu\text{m radial offset.}$$

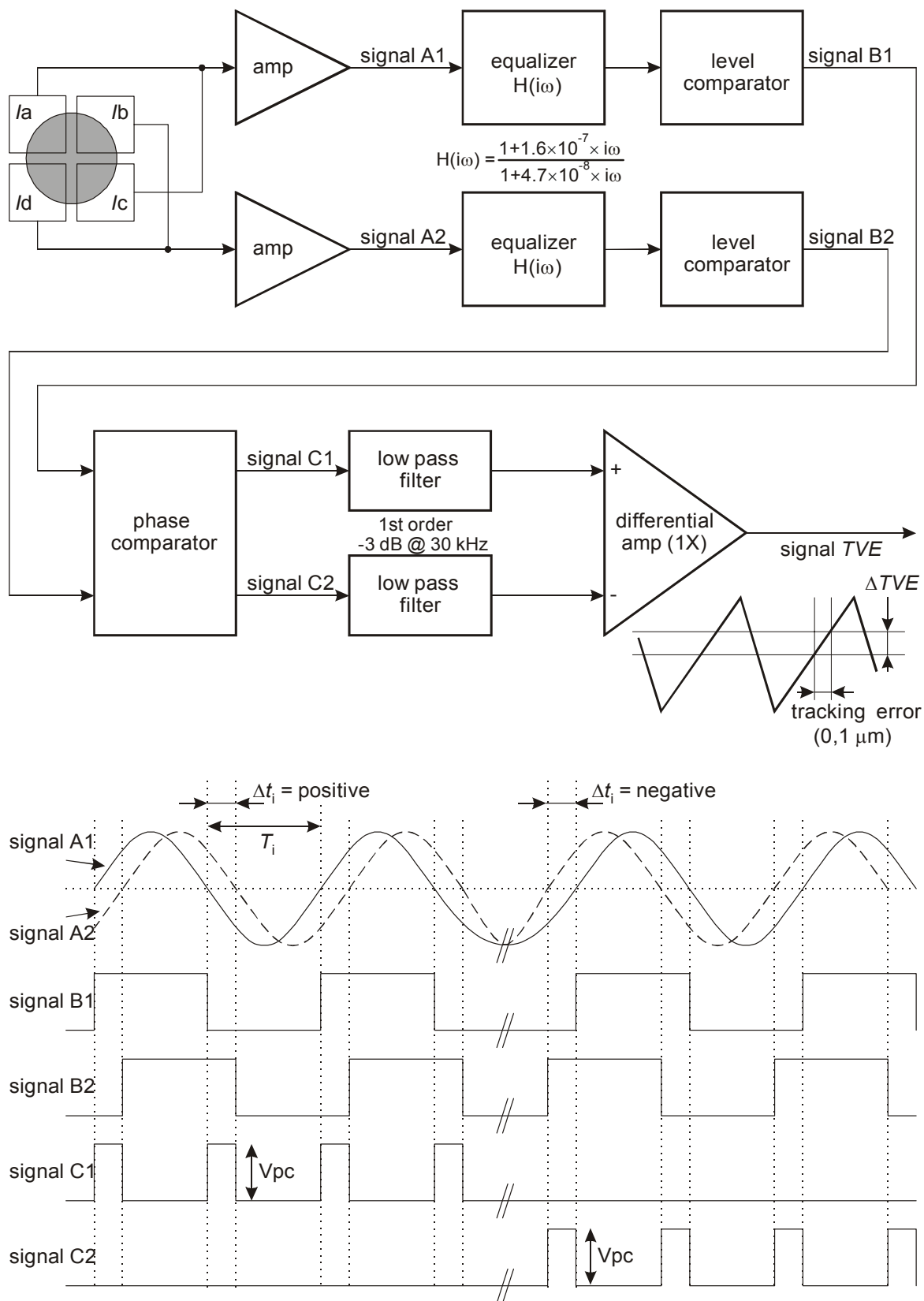

Figure E.1 - Circuit for tracking error measurements

E.3 Calibration of the circuit

Assuming that V_{pc} equals ≈ 5 V and that the measured value of n equals ≈ 5 , then the above relation between the tracking error amplitude $\overline{\Delta TVE}$ and the time difference $\overline{\Delta t}$ can be simplified to:

$$\overline{\Delta TVE} = \frac{\overline{\Delta t}}{T} \times \frac{V_{pc}}{n} \approx \frac{\overline{\Delta t}}{T}$$

The average runlength n of the 8-to-16 modulated signal is depending on the data content and the averaging time. Therefore the circuit shall be calibrated with a fixed frequency signal, corresponding to a modulated signal with 5T runlengths. For this purpose sinusoidal signals with a frequency of 2.616 MHz can be used.

Typically the pulses of signals C1 and C2 will be generated by some digital gate circuit with an output signal switching between ground and the supply voltage. This voltage swing is assumed to be about 5 volts, however, depending on the applied technology, it may deviate from 5 volts significantly.

Because the formal specification for the DPD signal is:

$$0.5 \leq \frac{\overline{\Delta t}}{T} \leq 1.1 \text{ at } 0.1 \mu\text{m radial offset,}$$

the measurement by means of $\overline{\Delta TVE}$ is influenced by the actual values of V_{pc} and n . Therefore the following calibration procedure shall be applied.

E.3.1 Saturation of comparators

Make sure that the gain of the level comparators is such that for all actual input signal levels, the signals B1 and B2 are square wave signals. In this case the amplitude of the signal TVE is independent of the amplitude of the input signals.

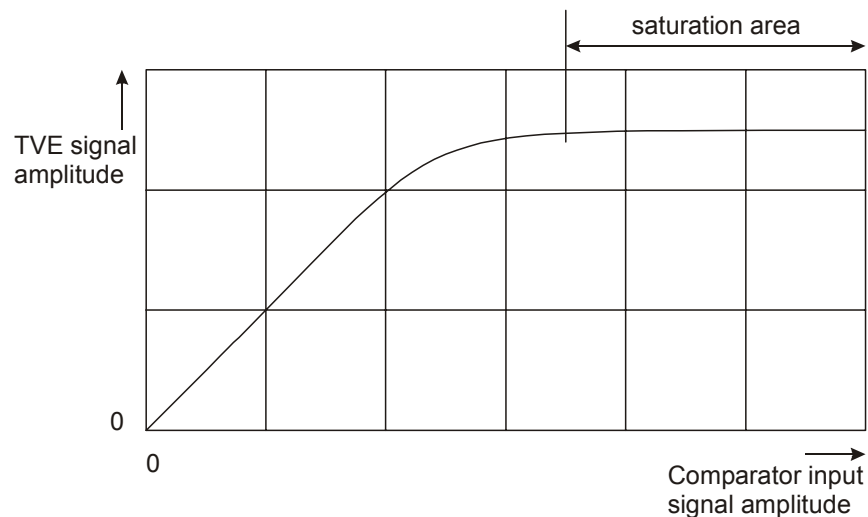

Figure E.2 - Tracking error signal amplitude versus comparator input signal amplitude

E.3.2 Correction for n and Vpc

Because of the above mentioned deviations of n and Vpc, and possibly some other circuit parameters, a correction factor K has to be determined, such that:

$$\overline{\Delta t/T}(\text{real}) = K \times \overline{\Delta TVE}(\text{measured}).$$

This can be achieved in the following way:

- a) Generate two sinusoidal signals A1 and A2 of frequency 2.616 MHz with a phase difference, and inject them into the two equalizer circuits.
- b) Measure the relation between $\overline{\Delta t/T}$ and $\overline{\Delta TVE}$, and determine K from Figure E.3:

$$K = \frac{\overline{\Delta t/T}(\text{injected})}{\overline{\Delta TVE}(\text{measured})}. \text{ Now the set-up is ready for use.}$$

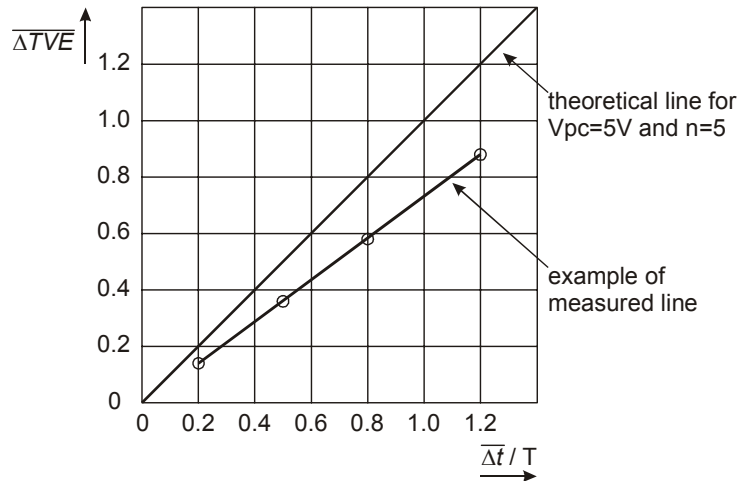

Figure E.3 - $\overline{\Delta TVE}$ versus $\overline{\Delta t/T}$

Annex F (normative)

The write pulse waveform for testing

For different speed ranges, different write strategies can be used. This version of this document specifies 2 options:

- a pulsed write strategy, where each single mark is created by a number of subsequent separated short pulses,
- a blocked write strategy, where each single mark is created by one continuous pulse.

F.1 Pulsed write strategy

The write pulse waveform obtained from the NRZI data and the channel clock is shown in Figure F.1. It consists of $N-2$ pulses, where N is the length of the NRZI pulse expressed in channel clock cycles.

The write pulse waveform for writing marks of length $N = 3$ consists of only the top pulse (T_{top}).

The write pulse waveform for writing marks of length $N \geq 4$ consist of the top pulse (T_{top}), $N-4$ multi-pulses (T_{mp}) and the last pulse (T_{lp}).

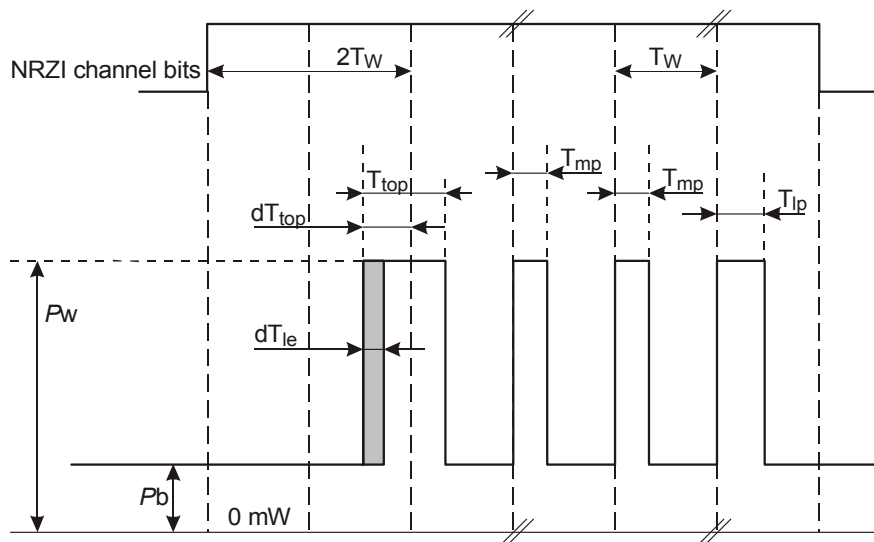

Figure F.1 - Write pulse waveform

The nominal pulse width times T_{mp} and T_{lp} shall be as indicated in the Physical format information in Table 3 and in 14.4.2.2. The duration can be dependent on the writing speed:

$$T_{mp} = m \times \frac{1}{16} T_W \quad \text{with } m = 4, 5, \dots \text{ or } 14 \quad (0,25 T_W \leq T_{mp} \leq 0,875 T_W)$$

$$T_{lp} = n \times \frac{1}{16} T_W \quad \text{with } n = 4, 5, \dots \text{ or } 24 \quad (0,25 T_W \leq T_{lp} \leq 1,5 T_W)$$

The laser power shall be switched to bias level between each pair of separated pulses for at least $\frac{2}{16} T_W$.

The nominal pulse width time T_{top} , is dependent upon the length of the current mark (cm). It shall be as indicated in the Physical format information in Table 3 and in 14.4.2.2. The duration can also be dependent on the writing speed:

$$T_{top} (cm=3) = i \times \frac{1}{16} T_W \quad \text{with } i = 4, 5, \dots \text{ or } 40 \quad (0,25 T_W \leq T_{top} \leq 2,5 T_W)$$

$$T_{top} (cm \geq 4) = j \times \frac{1}{16} T_W \quad \text{with } j = 4, 5, \dots \text{ or } 40 \quad (0,25 T_W \leq T_{top} \leq 2,5 T_W)$$

The nominal first pulse lead-time dT_{top} relative to the trailing edge of the second Channel bit of the NRZI data pulse, is dependent upon the length of the current mark (cm). It shall be as indicated in the Physical format information in Table 3 and in 14.4.2.2. The value of dT_{top} can also be dependent on the writing speed:

$$dT_{top} (cm=3) = p \times \frac{1}{16} T_W \quad \text{with } p = 0, 1, \dots \text{ or } 24 \quad (0,0 T_W \leq dT_{top} (cm=3) \leq 1,5 T_W)$$

$$dT_{top} (cm \geq 4) = q \times \frac{1}{16} T_W \quad \text{with } q = 0, 1, \dots \text{ or } 24 \quad (0,0 T_W \leq dT_{top} (cm \geq 4) \leq 1,5 T_W)$$

With the individual values for $T_{top} (cm=3)$ and $dT_{top} (cm=3)$, the 3T mark can be enhanced and shifted for optimum resulting jitter.

The widening of the 3T write pulse is: $\Delta T = \{T_{top} (cm=3) - T_{top} (cm \geq 4)\}$,
and the shift of the 3T write pulse is: $\delta T = \{dT_{top} (cm=3) - dT_{top} (cm \geq 4)\}$.

In principle the shift δT and the widening ΔT of the 3T pulse can be chosen independently. However because of limitations in certain implementations, for this version of this document there is one exception:

if a shift of the 3T pulse is needed, such a shift shall be combined with a widening resulting in a symmetrical change of the 3T write pulse.

Or in mathematical terms: if $\delta T \neq 0$, then ΔT shall be $= 2 \times \delta T$ (see Figure F.2).

The position of the leading edge and hence the length of the first pulse may be corrected by dT_{le} dependent upon the length of the previous space (ps). This feature is called "thermal balancing". dT_{le} shall be as indicated in the Physical format information in Table 3 and in 14.4.2.2. If the previous space is ≥ 4 channel clock cycles, then dT_{le} shall be 0. The value of dT_{le} can be dependent on the writing speed:

$$dT_{le} (ps = 3) = u \times \frac{1}{16} T_W \quad \text{with } u = 0, 1, \dots \text{ or } 4 \quad (0 \leq dT_{le} \leq 0,25 T_W)$$

(dT_{le} will give a delay and reduce the length of the first pulse as indicated in Figure F.1)

The values for P_w , and P_b are determined according to the OPC algorithm (see Annex H). An example of the write pulse waveform is shown in Figure F.2.

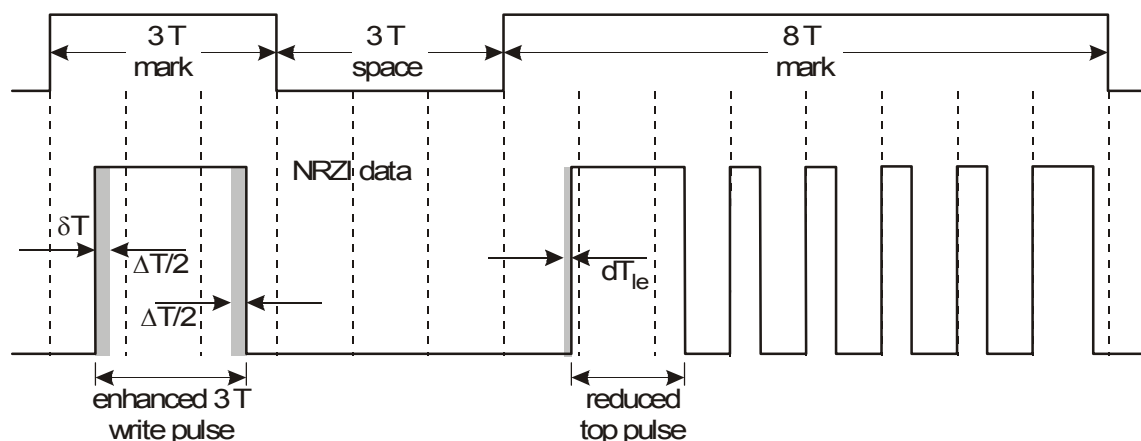

Figure F.2 - Example of a Multiple-pulse

F.2 Blocked write strategy

The waveform for the blocked write strategy (see Figure F.3) is derived from the waveform for the pulsed write strategy by setting T_{mp} equal to T_W ($m = 16$) and setting $T_{top}(cm \geq 4)$ equal to $dT_{top} + T_W$ ($j = q + 16$). $T_{top}(cm=3)$ can be optimised individually.

The write pulse waveform for writing marks of length $N = 3$ is a pulse with a length $T_{top}(cm=3)$.
 The write pulse waveform for writing marks of length $N \geq 4$ is a pulse with a length $dT_{top}(cm \geq 4) + (N-3) \times T_W + T_{Ip}$.

Especially at higher recording speeds, optimum cooling down of the recording layer after writing a mark may be needed. For this purpose the bias power shall be switched to P_c between the trailing edge of the write pulse and a quarter of the second Channel bit after the trailing edge of the NRZI data pulse. P_c shall be $< 0,1$ mW.

At higher recording speeds with a blocked write strategy also a power enhancement for the shorter marks might be needed. The additional power dP_w shall only be applied for the 3T and 4T marks and shall extend over the full width of the write pulse waveform (see Figures F.3 and F.4). It shall be as indicated in the Physical format information in Table 5 and in 14.4.2.3.1.

$$dP_w (cm=3) = \frac{y}{200} \times P_w \quad \text{with } y = 0, 1, \dots \text{ or } 100 \quad (0,00 P_w \leq dP_w \leq 0,50 P_w)$$

$$dP_w (cm=4) = \frac{z}{200} \times P_w \quad \text{with } z = 0, 1, \dots \text{ or } 100 \quad (0,00 P_w \leq dP_w \leq 0,50 P_w)$$

$$dP_w (cm \geq 5) = 0$$

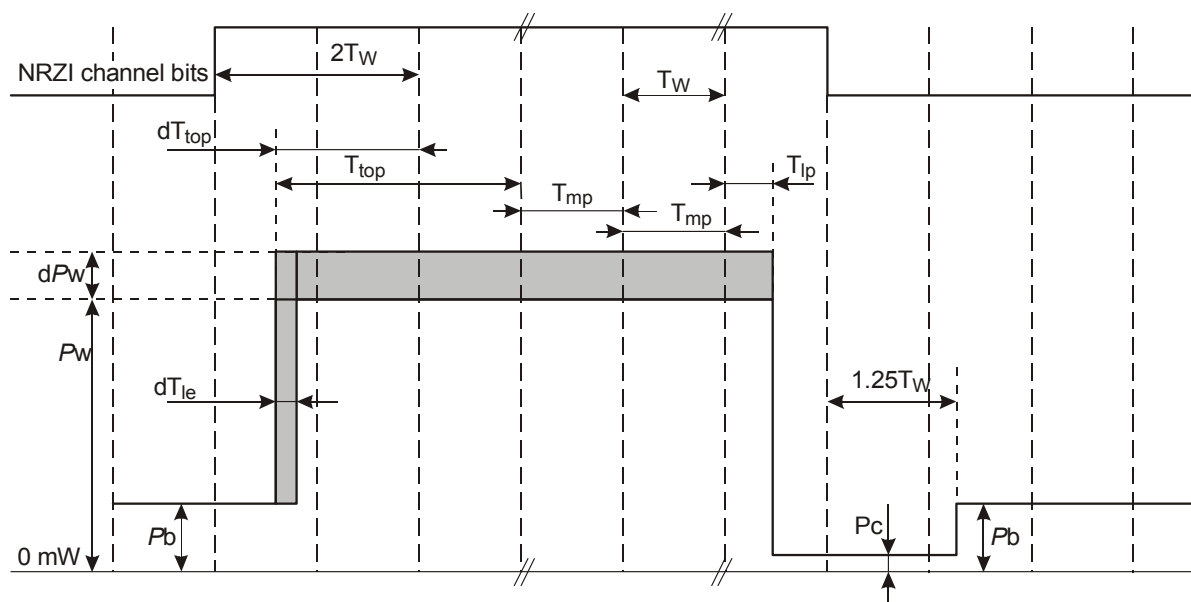

Figure F.3 – General blocked waveform

The nominal pulse width times T_{mp} and T_{Ip} shall be as indicated in the Physical format information in Table 5 and in 14.4.2.3.1. The duration can be dependent on the writing speed:

$$T_{mp} = m \times \frac{1}{16} T_W \quad \text{with } m = 16 \quad (T_{mp} = 1,0 T_W)$$

$$T_{Ip} = n \times \frac{1}{16} T_W \quad \text{with } n = 0, 1, \dots \text{ or } 16 \quad (0,0 T_W \leq T_{Ip} \leq 1,0 T_W)$$

The nominal pulse width time T_{top} , is dependent upon the length of the current mark (cm). It shall be as indicated in the Physical format information in Table 5 and in 14.4.2.3.1. The duration can also be dependent on the writing speed:

$$T_{top} (cm=3) = i \times \frac{1}{16} T_W \quad \text{with } i = 16, 17, \dots \text{ or } 48 \quad (1 T_W \leq T_{top} \leq 3 T_W)$$

$$T_{top} (cm \geq 4) = j \times \frac{1}{16} T_W \quad \text{with } j = 16, 17, \dots \text{ or } 48 \quad (1 T_W \leq T_{top} \leq 3 T_W)$$

($j = q + 16$, see at dT_{top})

The nominal first pulse lead-time dT_{top} relative to the trailing edge of the second Channel bit of the NRZI data pulse, is dependent upon the length of the current mark (cm). It shall be as indicated in the Physical format information in Table 5 and in 14.4.2.3.1. The value of dT_{top} can also be dependent on the writing speed:

$$dT_{top} (cm=3) = p \times \frac{1}{16} T_W \quad \text{with } p = 0, 1, \dots \text{ or } 32 \quad (0,0 T_W \leq dT_{top} (cm=3) \leq 2 T_W)$$

$$dT_{top} (cm \geq 4) = q \times \frac{1}{16} T_W \quad \text{with } q = 0, 1, \dots \text{ or } 32 \quad (0,0 T_W \leq dT_{top} (cm \geq 4) \leq 2 T_W)$$

($q = j - 16$, see at T_{top})

With the individual values for T_{top} (cm=3) and dT_{top} (cm=3) the 3T mark can be adapted and shifted for optimum resulting jitter.

The relative shift of the 3T write pulse is: $\delta T = \{dT_{top} (cm=3) - dT_{top} (cm \geq 4)\}$.

The position of the leading edge and hence the length of the first pulse may be corrected by dT_{le} dependent upon the length of the previous space (ps). This feature is called "thermal balancing". dT_{le} shall be as indicated in the Physical format information in Table 5 and in 14.4.2.3.1. If the previous space is ≥ 4 channel clock cycles, then dT_{le} shall be 0. The value of dT_{le} can be dependent on the writing speed:

$$dT_{le} (ps=3) = u \times \frac{1}{16} T_W \quad \text{with } u = 0, 1, \dots \text{ or } 4 \quad (0 \leq dT_{le} \leq 0,25 T_W)$$

(dT_{le} will give a delay and reduce the length of the first pulse as indicated in Figure F.3)

The values for P_w , and P_b are determined according to the OPC algorithm (see Annex H).

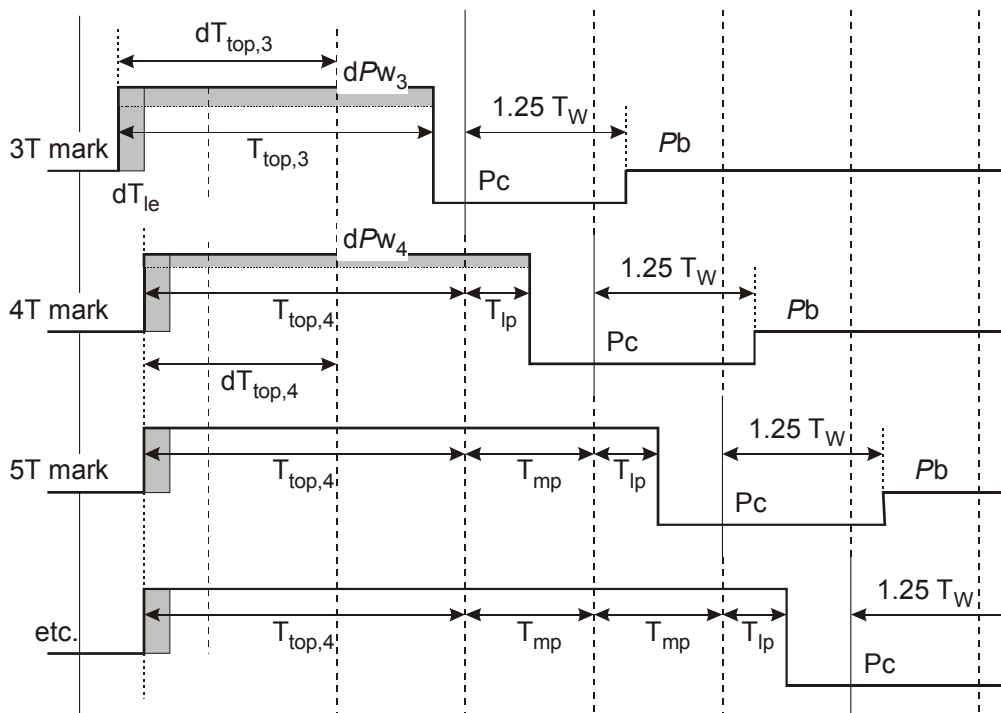

Figure F.4 - Examples of a "blocked" waveform

F.3 Rise and fall times

The rise times, T_r , and fall times, T_f , as specified in Figure F.5 shall not exceed 2 ns. Possible overshoots shall be $< 20\%$ of the step size P .

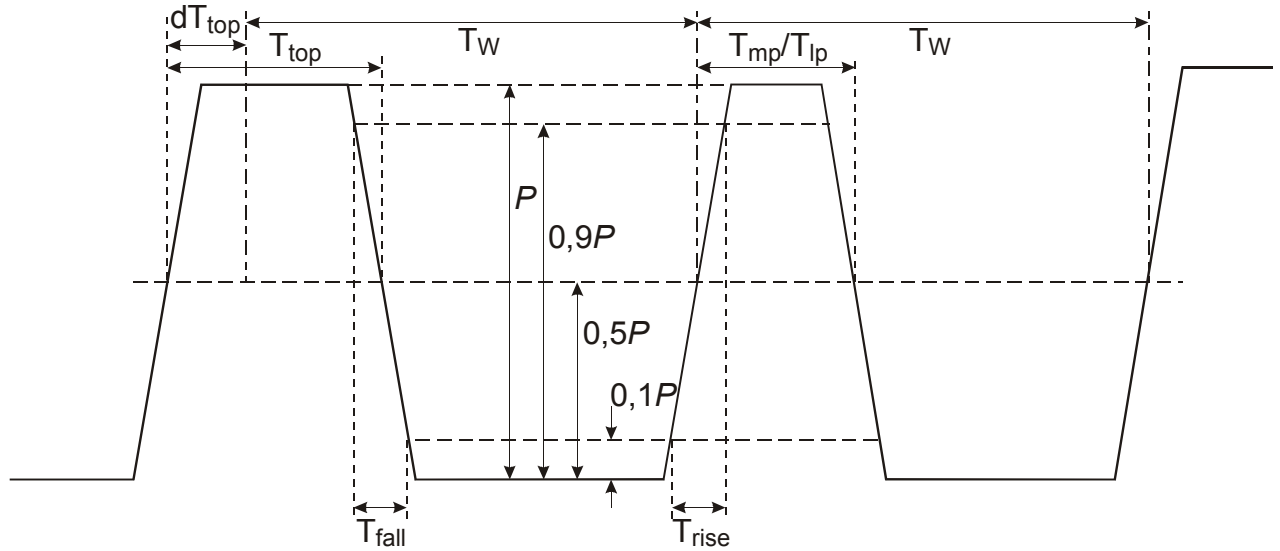

Figure F.5 - Rise Times and Fall Times



Annex G (normative)

8-to-16 Modulation

8-to-16 modulation shall satisfy RLL(2,10) requirements. The encoding system is shown in Figure G.1 with the conversion tables shown in Table G.1 and Table G.2.

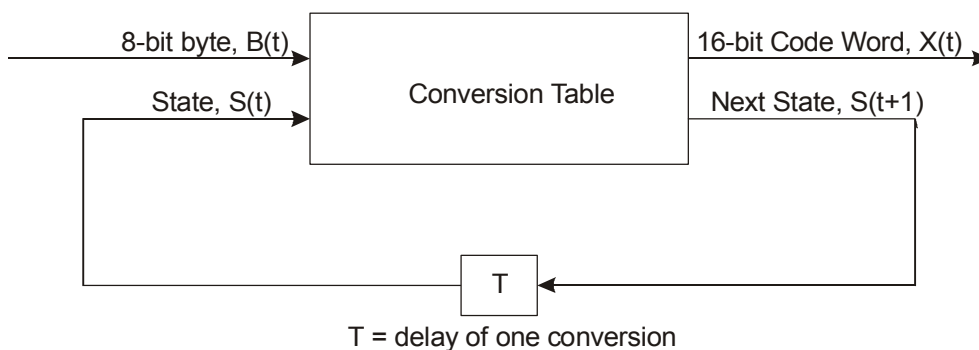

Where:

$$X(t) = H\{B(t), S(t)\} \quad X_{15}(t) = \text{msb and } X_0(t) = \text{lsb}$$

$$S(t+1) = G\{B(t), S(t)\}$$

H is the output function from the conversion tables

G is the next-state function from the conversion tables

Figure G.1 - Code Word generating system

The States of the Code Words, $X(t)$, shall be chosen to satisfy the RLL(2,10) requirements of a minimum of 2 ZEROs and a maximum of 10 ZEROs between ONEs of adjacent Code Words.

Code Word $X(t)$	Next State $X(t+1)$	Code Word $X(t+1)$
Ends with 1 or no trailing ZEROs	State 1	Starts with 2 to 9 leading ZEROs
Ends with 2 to 5 trailing ZEROs	State 2	Starts with 1 or up to 5 leading ZEROs and $X_{15}(t+1), X_3(t+1) = 0,0$
Ends with 2 to 5 trailing ZEROs	State 3	Starts with none or up to 5 leading ZEROs and $X_{15}(t+1), X_3(t+1) \neq 0,0$
Ends with 6 to 9 trailing ZEROs	State 4	Starts with 1 or no leading ZEROs

Figure G.2 - Determination of States

Note that when decoding the recorded data, knowledge about the encoder is required to be able to reconstitute the original bytes.

$$B(t) = H^{-1}\{X(t), S(t)\}$$

Because of the involved error propagation, such state-dependent decoding is to be avoided. In the case of this 8-to-16 modulation, the conversion tables have been chosen in such a way that knowledge about the State is not required in most cases. As can be gathered from the tables, in some cases, two 8-bit bytes, for

instance the 8-bit bytes 5 and 6 in States 1 and 2 in Table G.1 generate the same 16-bit Code Words. The construction of the tables allows to solve this apparent ambiguity. Indeed, if two identical Code Words leave a State, one of them goes to State 2 and the other to State 3. Because the setting of bits X_{15} and X_3 is always different in these two States, any Code Word can be uniquely decoded by analysing the Code Word itself together with bits X_{15} and X_3 of the next Code Word:

$$B(t) = H^{-1}\{ X(t), X_{15}(t+1), X_3(t+1) \}$$

The Substitution table, Table G.2, is included to insure meeting the DCC requirements of 13.8.

Table G.1 - Main Conversion Table

8-bit byte	State 1		State 2		State 3		State 4	
	Code Word msb	lsb Next State	Code Word msb	lsb Next State	Code Word msb	lsb Next State	Code Word msb	lsb Next State
0	001000000001001	1	0100000100100000	2	0010000000001001	1	0100000100100000	2
1	0010000000010010	1	0010000000010010	1	1000000100100000	3	1000000100100000	3
2	0010000100100000	2	0010000100100000	2	1000000000010010	1	1000000000010010	1
3	0010000001001000	2	0100010010000000	4	0010000001001000	2	0100010010000000	4
4	0010000010010000	2	0010000010010000	2	1000000100100000	2	1000000100100000	2
5	0010000000100100	2	0010000000100100	2	1001001000000000	4	1001001000000000	4
6	0010000000100100	3	0010000000100100	3	1000100100000000	4	1000100100000000	4
7	0010000001001000	3	0100000000010010	1	0010000001001000	3	0100000000010010	1
8	0010000010010000	3	0010000010010000	3	1000010010000000	4	1000010010000000	4
9	0010000010010000	3	0010000010010000	3	1001001000000001	1	1001001000000001	1
10	0010010010000000	4	0010010010000000	4	1000100100000001	1	1000100100000001	1
11	0010001001000000	4	0010001001000000	4	1000000100100000	3	1000000100100000	3
12	0010010010000001	1	0010010010000001	1	1000000010010000	2	1000000010010000	2
13	0010001001000001	1	0010001001000001	1	1000010010000001	1	1000010010000001	1
14	0010000001001001	1	0100000000100100	3	0010000001001001	1	0100000000100100	3
15	0010000010010001	1	0010000010010001	1	1000001001000001	1	1000001001000001	1
16	0010000010010001	1	0010000010010001	1	1000000100100001	1	1000000100100001	1
17	0010000000100010	1	0010000000100010	1	1000001001000000	4	1000001001000000	4
18	0001000000001001	1	0100000010010000	2	0001000000001001	1	0100000010010000	2
19	0010000000010001	1	0010000000010001	1	1001000100000000	4	1001000100000000	4
20	0001000000010010	1	0001000000010010	1	1000100010000000	4	1000100010000000	4
21	00001000000000010	1	00001000000000010	1	1000000010010001	1	1000000010010001	1
22	0000010000000001	1	0000010000000001	1	1000000001001001	1	1000000001001001	1
23	0010001000100000	2	0010001000100000	2	1000000001001000	2	1000000001001000	2
24	0010000100010000	2	0010000100010000	2	1000000001001000	3	1000000001001000	3
25	0010000010001000	2	0100000000100100	2	0010000010001000	2	0100000000100100	2
26	0010000001000100	2	0010000001000100	2	1000000000100010	1	1000000000100010	1
27	0001000100100000	2	0001000100100000	2	1000000000010001	1	1000000000010001	1
28	0010000000001000	2	0100000010010000	3	0010000000001000	2	0100000010010000	3
29	0001000010010000	2	0001000010010000	2	1001001000000010	1	1001001000000010	1
30	0001000000100100	2	0100000100100000	3	0001000000100100	2	0100000100100000	3
31	0001000000100100	2	0001000000100100	2	1001000100000001	1	1001000100000001	1
32	00010000000000100	2	00010000000000100	2	1000100100000010	1	1000100100000010	1
33	00010000000000100	3	00010000000000100	3	1000100010000001	1	1000100010000001	1
34	0001000000100100	3	0001000000100100	3	1000000000100100	2	1000000000100100	2
35	0001000001001000	3	0100001001000000	4	0001000001001000	3	0100001001000000	4
36	0001000010010000	3	0001000010010000	3	1000000000100100	3	1000000000100100	3
37	0001000100100000	3	0001000100100000	3	1000010001000000	4	1000010001000000	4
38	0010000000001000	3	0100100100000001	1	0010000000001000	3	0100100100000001	1
39	0010000001000100	3	0010000001000100	3	1001000010000000	4	1001000010000000	4
40	0010000010001000	3	0100010010000001	1	0010000010001000	3	0100010010000001	1
41	0010000100010000	3	0010000100010000	3	1000010010000010	1	1000010010000010	1
42	0010001000100000	3	0010001000100000	3	1000001000100000	2	1000001000100000	2
43	0010010001000000	4	0010010001000000	4	1000010001000001	1	1000010001000001	1
44	0001001001000000	4	0001001001000000	4	1000001000100000	3	1000001000100000	3
45	0000001000000001	1	0100010001000000	4	1000001001000010	1	0100010001000000	4
46	0010010010000010	1	0010010010000010	1	1000001000100001	1	1000001000100001	1
47	0010000010001001	1	0100001001000001	1	0010000010001001	1	0100001001000001	1
48	0010010001000001	1	0010010001000001	1	1000000100010000	2	1000000100010000	2
49	0010001001000010	1	0010001001000010	1	1000000010001000	2	1000000010001000	2
50	0010001000100001	1	0010001000100001	1	1000000100010000	3	1000000100010000	3

Table G.1 - Main Conversion Table (continued)

51	0001000001001001	1	0100000100100001	1	0001000001001001	1	0100000100100001	1
52	0010000100100010	1	0010000100100010	1	1000000100100010	1	1000000100100010	1
53	0010000100010001	1	0010000100010001	1	1000000100010001	1	1000000100010001	1
54	0010000010010010	1	0010000010010010	1	1000000010010010	1	1000000010010010	1
55	0010000001000010	1	0010000001000010	1	1000000010000010	1	1000000010000010	1
56	0010000000100001	1	0010000000100001	1	1000000001000001	1	1000000001000001	1
57	0000100000001001	1	0100000010010001	1	0000100000001001	1	0100000010010001	1
58	0001001001000001	1	0001001001000001	1	1000000000100001	1	1000000000100001	1
59	0001000100100001	1	0001000100100001	1	0100000001001001	1	0100000001001001	1
60	0001000010010001	1	0001000010010001	1	1001001000010010	1	1001001000010010	1
61	0001000000100010	1	0001000000100010	1	1001001000001001	1	1001001000001001	1
62	0001000000010001	1	0001000000010001	1	1001000100000010	1	1001000100000010	1
63	0000100000010010	1	0000100000010010	1	1000000001000100	2	1000000001000100	2
64	0000010000000010	1	0000010000000010	1	0100000001001000	2	0100000001001000	2
65	0010010000100000	2	0010010000100000	2	1000010000100000	2	1000010000100000	2
66	0010001000010000	2	0010001000010000	2	1000001000010000	2	1000001000010000	2
67	0010000010000100	2	0100000000100010	1	0010000100001000	2	0100000000100010	1
68	0010000001000010	2	0010000001000010	2	1000000100001000	2	1000000100001000	2
69	0010000000010000	2	0010000000010000	2	1000000010000100	2	1000000010000100	2
70	0001000010001000	2	0100001000100000	2	0001000010001000	2	0100001000100000	2
71	0001001000100000	2	0001001000100000	2	0100000010001000	2	0100000010001000	2
72	0001000000001000	2	0100000100010000	2	0001000000001000	2	0100000100010000	2
73	0001000100010000	2	0001000100010000	2	1000000001000100	3	1000000001000100	3
74	0001000000100010	2	0001000000100010	2	0100000001001000	3	0100000001001000	3
75	0000100100100000	2	0000100100100000	2	1000010000100000	3	1000010000100000	3
76	0000100010010000	2	0000100010010000	2	1000001000010000	3	1000001000010000	3
77	0000100001001000	2	0100000001000100	2	0000100001001000	2	0100000001000100	2
78	0000100000100100	2	0000100000100100	2	1000000100001000	3	1000000100001000	3
79	0000100000000100	2	0000100000000100	2	1000000010000100	3	1000000010000100	3
80	0000100000000010	3	0000100000000010	3	0100000010001000	3	0100000010001000	3
81	0000100000100100	3	0000100000100100	3	1000100001000000	4	1000100001000000	4
82	0000100001001000	3	0100000001000100	3	0000100001001000	3	0100000001000100	3
83	0000100010010000	3	0000100010010000	3	1000000010001000	3	1000000010001000	3
84	0000100100100000	3	0000100100100000	3	1001001001001000	2	1001001001001000	2
85	0001000000000100	3	0100000100000100	3	0001000000000100	3	0100000100000100	3
86	0001000000100010	3	0001000000100010	3	1001001000100100	2	1001001000100100	2
87	0001000010001000	3	0100001000100000	3	0001000010001000	3	0100001000100000	3
88	0001000100010000	3	0001000100010000	3	1001001001001000	3	1001001001001000	3
89	0001001000100000	3	0001001000100000	3	1001000010000001	1	1001000010000001	1
90	0010000000010000	3	0010000000010000	3	1000100100010010	1	1000100100010010	1
91	0010000010000100	3	0010000010000100	3	1000100100001001	1	1000100100001001	1
92	0010000100001000	3	0100000000010001	1	0010000100001000	3	0100000000010001	1
93	0010001000010000	3	0010001000010000	3	1000100010000010	1	1000100010000010	1
94	0010010000100000	3	0010010000100000	3	1000100001000001	1	1000100001000001	1
95	0000001000000010	1	0100100100000010	1	1000010010010010	1	0100100100000010	1
96	0000000100000001	1	0100100010000001	1	1000010010001001	1	0100100010000001	1
97	0010010010001001	1	0100010000100000	2	0010010010001001	1	0100010000100000	2
98	0010010010010010	1	0010010010010010	1	1001001000000100	2	1001001000000100	2
99	0010010001000010	1	0010010001000010	1	1001001000100100	3	1001001000100100	3
100	0010010000100001	1	0010010000100001	1	1000010001000010	1	1000010001000010	1
101	0010001001001001	1	0100010010000010	1	0010001001001001	1	0100010010000010	1
102	0010001000100010	1	0010001000100010	1	1000010000100001	1	1000010000100001	1
103	00100001000010001	1	00100001000010001	1	10000001001001001	1	10000001001001001	1
104	0010000100010010	1	0010000100010010	1	1000001000100010	1	1000001000100010	1
105	0010000010000010	1	0010000010000010	1	1000001000010001	1	1000001000010001	1
106	00100000100001001	1	0100001000010000	2	0010000100001001	1	0100001000010000	2
107	0010000001000001	1	0010000001000001	1	1000000100010010	1	1000000100010010	1
108	0001001001000010	1	0001001001000010	1	1000000100001001	1	1000000100001001	1
109	0001001000100001	1	0001001000100001	1	1000000010000010	1	1000000010000010	1
110	0001000100100010	1	0001000100100010	1	1000000001000001	1	1000000001000001	1
111	0001000100010001	1	0001000100010001	1	0100000010001001	1	0100000010001001	1
112	0001000010010010	1	0001000010010010	1	1001001001001001	1	1001001001001001	1
113	00010000001000010	1	00010000001000010	1	1001001000100010	1	1001001000100010	1
114	000100000001000101	1	0100010000100000	3	0001000010001001	1	0100010000100000	3
115	00010000000100001	1	00010000000100001	1	1001001000010001	1	1001001000010001	1
116	0000100100100001	1	0000100100100001	1	1001000100010010	1	1001000100010010	1

Table G.1 - Main Conversion Table (continued)

117	0000100010010001	1	0000100010010001	1	1001000100001001	1	1001000100001001	1
118	0000100001001001	1	0100010001000001	1	0000100001001001	1	0100010001000001	1
119	0000100000100010	1	0000100000100010	1	1000100100100100	2	1000100100100100	2
120	0000100000010001	1	0000100000010001	1	1000100100000100	2	1000100100000100	2
121	0000010000001001	1	0100001001000010	1	0000010000001001	1	0100001001000010	1
122	0000010000010010	1	0000010000010010	1	1000100000100000	2	1000100000100000	2
123	0010010010000100	2	0010010010000100	2	1000010010000100	2	1000010010000100	2
124	0010010000010000	2	0010010000010000	2	1000010000010000	2	1000010000010000	2
125	00100001000001000	2	0100001000100001	1	0010001000001000	2	0100001000100001	1
126	00100001001000100	2	00100001001000100	2	1000001001000100	2	1000001001000100	2
127	00010001000001000	2	0100000100100010	1	00010001000001000	2	0100000100100010	1
128	00100000100100100	2	00100000100100100	2	1000001000001000	2	1000001000001000	2
129	00001000100010000	2	0100000100010001	1	00001000100010000	2	0100000100010001	1
130	00100001000001000	2	00100001000001000	2	1000000100100100	2	1000000100100100	2
131	00100000000100000	2	00100000000100000	2	10010010000000100	3	10010010000000100	3
132	00010010000100000	2	00010010000100000	2	1000100100100100	3	1000100100100100	3
133	00001000000010000	2	0100000010010010	1	00001000000010000	2	0100000010010010	1
134	00010000100001000	2	00010000100001000	2	1000100000100000	3	1000100000100000	3
135	00010000000010000	2	00010000000010000	2	1000010010000100	3	1000010010000100	3
136	00001001000100000	2	00001001000100000	2	1000010000010000	3	1000010000010000	3
137	00001000010001000	2	00001000010001000	2	1000001001000100	3	1000001001000100	3
138	00000100010010000	2	0100000001000010	1	00000100010010000	2	0100000001000010	1
139	00000100100100000	2	00000100100100000	2	1000001000001000	3	1000001000001000	3
140	00000100001001000	2	00000100001001000	2	10010000010000010	1	10010000010000010	1
141	00000100000000100	2	00000100000000100	2	1000000100000100	2	1000000100000100	2
142	00000100000000100	3	00000100000000100	3	1000000100100100	3	1000000100100100	3
143	00000100001001000	3	00000100001001000	3	1000000100000100	3	1000000100000100	3
144	00000100010010000	3	0100000010000100	2	00000100010010000	3	0100000010000100	2
145	00000100100100000	3	00000100100100000	3	1000000001000000	4	1000000001000000	4
146	00001000000001000	3	01000000000100000	2	00001000000001000	3	01000000000100000	2
147	00001000010001000	3	00001000010001000	3	1000000000100000	2	1000000000100000	2
148	00001000100010000	3	0100000010000100	3	00001000100010000	3	0100000010000100	3
149	00001001000100000	3	00001001000100000	3	1000000000100000	3	1000000000100000	3
150	00010000000010000	3	00010000000010000	3	0100000100001000	3	0100000100001000	3
151	00010000100001000	3	00010000100001000	3	1000000001000000	4	1000000001000000	4
152	00010001000010000	3	01000001000010000	3	00010001000010000	3	01000001000010000	3
153	00010010000100000	3	00010010000100000	3	1001000001000001	1	1001000001000001	1
154	00100000000100000	3	00100000000100000	3	01000001000001000	2	01000001000001000	2
155	00100001000001000	3	00100001000001000	3	1001000100100100	3	1001000100100100	3
156	00100001001001000	3	00100001001001000	3	1000100100100010	1	1000100100100010	1
157	00100001000001000	3	0100000000100001	1	00100001000001000	3	0100000000100001	1
158	00100001001000100	3	00100001001000100	3	1000100100000100	3	0100100100000000	4
159	00100100000100000	3	00100100000100000	3	1001001001000100	2	1001001001000100	2
160	00100100100001000	3	00100100100001000	3	1001001000001000	2	1001001000001000	2
161	00000010000100100	1	01000000000100000	3	1000100100010001	1	01000000000100000	3
162	00000010000001001	1	0100100100100100	2	1000100010010010	1	0100100100100100	2
163	00000001000000100	1	0100100100100100	3	1000100010001001	1	0100100100100100	3
164	00000000100000001	1	0100100100010010	1	1000100001000010	1	0100100100010010	1
165	0010010010010001	1	0010010010010001	1	1001000100100100	2	1001000100100100	2
166	00100100001000100	1	00100100001000100	1	1001000100000100	2	1001000100000100	2
167	0010010001001001	1	0100100100000100	2	0010010001001001	1	0100100100000100	2
168	0010010000010001	1	0010010000010001	1	1001001001000100	3	1001001001000100	3
169	00100001000010010	1	00100001000010010	1	1000100000100001	1	1000100000100001	1
170	00100001000000100	1	00100001000000100	1	1000010010010001	1	1000010010010001	1
171	00100001000001001	1	01001000000100000	3	0010001000001001	1	01001000000100000	3
172	00100000100000001	1	00100000100000001	1	1000010001001001	1	1000010001001001	1
173	00010010001000100	1	00010010001000100	1	1000010000100010	1	1000010000100010	1
174	00010010000010001	1	00010010000010001	1	1000010000010001	1	1000010000010001	1
175	00010000100010010	1	00010000100010010	1	1000001000010010	1	1000001000010010	1
176	00010000010000010	1	00010000010000010	1	1000001000001001	1	1000001000001001	1
177	0001001001001001	1	0100100010000010	1	0001001001001001	1	0100100010000010	1
178	00010000010000001	1	00010000010000001	1	1000000100000010	1	1000000100000010	1
179	00001001001000100	1	00001001001000100	1	1000000010000001	1	1000000010000001	1
180	00001001000010001	1	00001001000010001	1	0100100100001001	1	0100100100001001	1
181	0001000100001001	1	01001000000100000	2	0001000100001001	1	01001000000100000	2
182	0000100010010010	1	0000100010010010	1	0100010010001001	1	0100010010001001	1

Table G.1 - Main Conversion Table (continued)

183	0000100001000010	1	0000100001000010	1	0100001001001001	1	0100001001001001	1
184	0000100010001001	1	0100010010000100	3	0000100010001001	1	0100010010000100	3
185	0000100000100001	1	0000100000100001	1	1001000000100000	2	1001000000100000	2
186	0000010010010001	1	0000010010010001	1	1000100100001000	2	1000100100001000	2
187	0000010000100010	1	0000010000100010	1	1000100010000100	2	1000100010000100	2
188	0000010001001001	1	0100100001000001	1	0000010001001001	1	0100100001000001	1
189	0000010000010001	1	0000010000010001	1	1000100000010000	2	1000100000010000	2
190	0000001001001000	2	0100010010000100	2	1000010010001000	2	0100010010000100	2
191	0000001000100100	2	0100010000010000	2	1000010001000100	2	0100010000010000	2
192	0000001000000100	2	0100001001000100	2	1000010000001000	2	0100001001000100	2
193	0010010010001000	2	0100010000010000	3	0010010010001000	2	0100010000010000	3
194	0010010001000100	2	0010010001000100	2	1000001001001000	2	1000001001001000	2
195	0010010000001000	2	0100010010010010	1	0010010000001000	2	0100010010010010	1
196	0010001000100100	2	0010001000100100	2	1000001000100100	2	1000001000100100	2
197	0010001000000100	2	0010001000000100	2	1000001000000100	2	1000001000000100	2
198	0010001001001000	2	0100010001000010	1	0010001001001000	2	0100010001000010	1
199	0001001001000100	2	0001001001000100	2	0100001000001000	2	0100001000001000	2
200	0001000100100100	2	0001000100100100	2	1001000000100000	3	1001000000100000	3
201	0001000100000100	2	0001000100000100	2	1000100100001000	3	1000100100001000	3
202	0001001000001000	2	0100010000100001	1	0001001000001000	2	0100010000100001	1
203	0001000000100000	2	0001000000100000	2	1000100010000100	3	1000100010000100	3
204	0000100010000100	2	0000100010000100	2	1000010010001000	3	1000010010001000	3
205	0000100000010000	2	0000100000010000	2	1000010001000100	3	1000010001000100	3
206	0000100100001000	2	0100001000100010	1	0000100100001000	2	0100001000100010	1
207	0000010010001000	2	0100001000010001	1	0000010010001000	2	0100001000010001	1
208	0000010001000100	2	0000010001000100	2	1000001000100100	3	1000001000100100	3
209	0000010000001000	2	0100000100010010	1	0000010000001000	2	0100000100010010	1
210	0000001000000100	3	0100000010000010	1	1000010000001000	3	0100000010000010	1
211	0000001000100100	3	0100000100100100	2	1000001001001000	3	0100000100100100	2
212	0000001001001000	3	0100000100000100	2	1000001000000100	3	0100000100000100	2
213	0000010000001000	3	0100000001000001	1	0000010000001000	3	0100000001000001	1
214	0000010001000100	3	0000010001000100	3	0100001000001000	3	0100001000001000	3
215	0000010010001000	3	0100000000100000	2	0000010010001000	3	0100000000100000	2
216	0000100000010000	3	0000100000010000	3	1001001000010000	3	1001001000010000	3
217	0000100010000100	3	0000100010000100	3	1001000100000100	3	1001000100000100	3
218	0000100100001000	3	0100000100000100	3	0000100100001000	3	0100000100000100	3
219	0001000000100000	3	0001000000100000	3	0100000100001001	1	0100000100001001	1
220	0001000100000100	3	0001000100000100	3	1001001000010000	2	1001001000010000	2
221	0001000100100100	3	0001000100100100	3	1001000100001000	2	1001000100001000	2
222	0001001000001000	3	0100000100100100	3	0001001000001000	3	0100000100100100	3
223	0001001001000100	3	0001001001000100	3	1001001000001000	3	1001001000001000	3
224	0010001000000100	3	0010001000000100	3	1000100000010000	3	1000100000010000	3
225	0010001000100100	3	0010001000100100	3	1001001001000010	1	1001001001000010	1
226	0010001001001000	3	0100001001000100	3	0010001001001000	3	0100001001000100	3
227	0010010000001000	3	0100100100000100	3	0010010000001000	3	0100100100000100	3
228	0010010001000100	3	0010010001000100	3	1001000100001000	3	1001000100001000	3
229	0010010010001000	3	0100000000100000	3	0010010010001000	3	0100000000100000	3
230	0010000001000000	4	0010000001000000	4	1001001000100001	1	1001001000100001	1
231	0000001001001001	1	0100100100100010	1	1001000100100010	1	0100100100100010	1
232	0000001000100010	1	0100100010000100	2	1001000100010001	1	0100100010000100	2
233	0000001000010001	1	0100100000010000	2	1001000010010010	1	0100100000010000	2
234	0000000100010010	1	0100000001000000	4	1001000010001001	1	0100000001000000	4
235	0000000100001001	1	0100100100010001	1	1001000001000010	1	0100100100010001	1
236	0000000010000010	1	0100100010010010	1	1001000000100001	1	0100100010010010	1
237	0000000001000001	1	0100100001000010	1	1000100100100001	1	0100100001000010	1
238	0010010000010010	1	0010010000010010	1	1000100010010001	1	1000100010010001	1
239	0010001000000010	1	0010001000000010	1	1001000010000100	3	1001000010000100	3
240	0010010000001001	1	0100100010000100	3	0010010000001001	1	0100100010000100	3
241	0010000100000001	1	0010000100000001	1	1001000010000100	2	1001000010000100	2
242	0001001000010010	1	0001001000010010	1	1000000010000000	4	1000000010000000	4
243	0001000100000010	1	0001000100000010	1	1000100001001001	1	1000100001001001	1
244	0001001000000100	1	0100100000100001	1	0001001000001001	1	0100100000010000	1
245	0001000010000001	1	0001000010000001	1	1000100000100010	1	1000100000100010	1
246	00001000100010010	1	00001000100010010	1	1000100000010001	1	1000100000010001	1
247	0000100010000010	1	0000100010000010	1	1000010000010010	1	1000010000010010	1
248	0000100100001001	1	0100010010010001	1	0000100100001001	1	0100010010010001	1

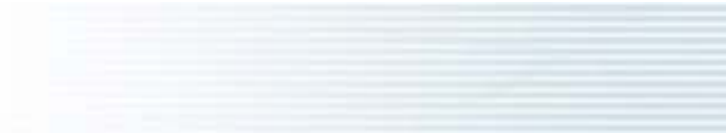

Table G.1 - Main Conversion Table (concluded)

249	0000100001000001	1	0000100001000001	1	1000010000001001	1	1000010000001001	1
250	0000010010010010	1	0000010010010010	1	1000001000000010	1	1000001000000010	1
251	0000010001000010	1	0000010001000010	1	1000000100000001	1	1000000100000001	1
252	0000010010001001	1	0100010000100010	1	0000010010001001	1	0100010000100010	1
253	0000010000100001	1	0000010000100001	1	0100100010001001	1	0100100010001001	1
254	0000001001000100	2	0100010000010001	1	1001000000010000	2	0100010000010001	1
255	0000001000001000	2	0100001000010010	1	1000100100010000	2	0100001000010010	1

Table G.2 – Substitution Conversion Table

8-bit byte	State 1			State 2			State 3			State 4		
	Code Word		Next State	Code Word		Next State	Code Word		Next State	Code Word		Next State
	msb	lsb		msb	lsb		msb	lsb		msb	lsb	
0	000010010000000	4	000010010000000	4	0100100001001000	2	0100100001001000	2				
1	000010010000000	4	000010010000000	4	0100100001001000	3	0100100001001000	3				
2	000100100000000	4	000100100000000	4	0100100000001001	1	0100100000001001	1				
3	000000100100000	4	0100010000000001	1	1000001000000000	4	0100010000000001	1				
4	000000010010000	3	0100100000000010	1	1001000000000100	3	0100100000000010	1				
5	000000001001000	3	0100001000000000	4	1001000000100100	3	0100001000000000	4				
6	000000001001000	3	0100100000000100	2	1001000001001000	3	0100100000000100	2				
7	0000000001001000	2	0100000100000000	4	1001000000000100	2	0100000100000000	4				
8	0000000001001000	2	0100100010010000	3	1001000000100100	2	0100100010010000	3				
9	0000000010010000	2	0100100000100100	2	1001000001001000	2	0100100000100100	2				
10	0000010001000000	4	0000010001000000	4	1001001001000000	4	1001001001000000	4				
11	0000100010000000	4	0000100010000000	4	1000100001001000	3	1000100001001000	3				
12	0001000100000000	4	0001000100000000	4	1000100010010000	3	0100010001001000	3				
13	0010001000000000	4	0010001000000000	4	1000100000000100	3	1000100000000100	3				
14	0000001000100000	3	0100100000000100	3	1001000010010000	3	0100100000000100	3				
15	00000000100010000	3	0100100010010000	2	1001000100100000	3	0100100010010000	2				
16	00000000010001000	3	0100001000000001	1	0100100000001000	3	0100001000000001	1				
17	00000000010001000	3	0100010000000010	1	0100010000100000	3	0100010000000010	1				
18	00000000010001000	2	01001000000100100	3	10010000010010000	2	01001000000100100	3				
19	00000000010001000	2	01001001001000000	3	10010001001000000	2	01001001001000000	3				
20	00000000100010000	2	01001001001000000	2	01000100010010000	2	01001001001000000	2				
21	00000001000100000	2	0100100000010010	1	0100100000001000	2	0100100000010010	1				
22	00000100100000001	1	00000100100000001	1	1000100000100100	3	1000100000100100	3				
23	00001001000000001	1	00001001000000001	1	1000100010010000	3	1000100010010000	3				
24	00010010000000001	1	00010010000000001	1	0100100010001000	2	0100100010001000	2				
25	00100100000000001	1	00100100000000001	1	1000100000000100	2	1000100000000100	2				
26	0000000001001001	1	0100010000000100	3	1000010000000001	1	0100010000000100	3				
27	0000000010010001	1	0100000100000001	1	1000100000000010	1	0100000100000001	1				
28	00000000100100001	1	0100010000000010	2	1001000000001001	1	0100010000000010	2				
29	0000001001000001	1	0100001000000010	1	1001000000010010	1	0100001000000010	1				
30	00001000010000000	4	00001000010000000	4	1000100000100100	2	1000100000100100	2				
31	00010000010000000	4	00010000010000000	4	1000100001001000	2	1000100001001000	2				
32	00100000100000000	4	00100000100000000	4	0100010000001001	1	0100010000001001	1				
33	00000100001000000	3	00000100001000000	3	0100100001001001	1	0100100001001001	1				
34	00000010000100000	3	0100010000010010	1	1000100100100000	3	0100010000010010	1				
35	00000000100001000	3	0100100000010001	1	1001000000001000	3	0100100000010001	1				
36	00000000010000100	3	0100000010000000	4	1001000001000100	3	0100000010000000	4				
37	00000100001000000	2	00000100001000000	2	1000001000000001	1	1000001000000001	1				
38	00000000100001000	2	01000100001001000	3	1000100010010000	2	01000100001001000	3				
39	00000000100001000	2	01000100001001000	2	1000100100100000	2	01000100001001000	2				
40	00000010000100000	2	0100100000100010	1	1001000000001000	2	0100100000100010	1				
41	00000100010000001	1	00000100010000001	1	1000010000000010	1	1000010000000010	1				
42	00000100100000010	1	00000100100000010	1	1000000100000000	4	1000000100000000	4				
43	00001000100000001	1	00001000100000001	1	1001000001000100	2	1001000001000100	2				
44	00001001000000010	1	00001001000000010	1	1000100000001001	1	1000100000001001	1				
45	00010000100000001	1	00010000100000001	1	10010000010001000	3	10010000010001000	3				
46	00010010000000010	1	00010010000000010	1	10010000010001000	3	10010000010001000	3				
47	00100010000000001	1	00100010000000001	1	1000100000010010	1	1000100000010010	1				
48	00100100000000010	1	00100100000000010	1	0100010000001000	3	0100010000001000	3				
49	00000000010000010	1	01001000100100001	1	1001000000010001	1	01001000100100001	1				
50	00000000010001001	1	01001000010001000	3	1001000000100010	1	01001000010001000	3				
51	00000000010010010	1	01000100100100000	3	1001000001001001	1	01000100100100000	3				
52	00000000100010001	1	01000100100100000	2	10010000010010001	1	01000100100100000	2				
53	00000000100100010	1	01001000010001000	2	10010001001000001	1	01001000010001000	2				
54	00000000010000001	1	01001001001000001	1	10010010010000001	1	01001001001000001	1				
55	00000000100000010	1	01001001000100000	3	01000010000001001	1	01001001000100000	3				
56	00010000010000000	4	00010000010000000	4	10010010001000000	3	10010010001000000	3				
57	00100000010000000	4	00100000010000000	4	10010000010001000	2	10010000010001000	2				
58	00100100010000000	3	00100100010000000	3	10010000010001000	2	10010000010001000	2				
59	00100100000100000	3	01001001000100000	2	00100100010001000	3	01001001000001000	2				
60	00100100000100100	3	00100100000100100	3	10010010001000000	2	10010010001000000	2				
61	00100100000000100	3	00100100000000100	3	01000010010010000	2	01000010010010000	2				

Table G.2 - Substitution Conversion Table (concluded)

62	0001001001001000	3	0100000010000001	1	0001001001001000	3	0100000010000001	1
63	0001001000100100	3	0001001000100100	3	0100001001001000	3	0100001001001000	3
64	0001001000000100	3	0001001000000100	3	0100010010001000	3	0100010010001000	3
65	0000100100100100	3	0000100100100100	3	0100100100001000	3	0100100100001000	3
66	0000100100000100	3	0000100100000100	3	1000010000000100	3	1000010000000100	3
67	0000100000100000	3	0000100000100000	3	1000010000100100	3	1000010000100100	3
68	0000010010000100	3	0000010010000100	3	1000010001001000	3	1000010001001000	3
69	0000010000010000	3	0000010000010000	3	1000010010010000	3	1000010010010000	3
70	0000001001000100	3	0100001000000100	2	1000100000001000	3	0100001000000100	2
71	0000001000001000	3	0100100000010000	3	1000100010001000	3	0100100000010000	3
72	0000000100100100	3	0100010001000100	3	1000100100010000	3	0100010001000100	3
73	0000000100000100	3	0100001000100100	3	1001000000010000	3	0100001000100100	3
74	0000010000010000	2	0000010000010000	2	1000100001000100	3	1000100001000100	3
75	0001001001001000	2	0100001000000100	3	0001001001001000	2	0100001000000100	3
76	0000010010000100	2	0000010010000100	2	0100010000001000	2	0100010000001000	2
77	0000100000100000	2	0000100000100000	2	0100010010001000	2	0100010010001000	2
78	0010010001001000	2	0100000100000010	1	0010010001001000	2	0100000100000010	1
79	0000100100000100	2	0000100100000100	2	0100100100001000	2	0100100100001000	2
80	0000100100100100	2	0000100100100100	2	1000010000000100	2	1000010000000100	2
81	0001001000000100	2	0001001000000100	2	1000010000100100	2	1000010000100100	2
82	0001001000100100	2	0001001000100100	2	1000010001001000	2	1000010001001000	2
83	0010010000000100	2	0010010000000100	2	1000010010010000	2	1000010010010000	2
84	0010010000100100	2	0010010000100100	2	1000100000001000	2	1000100000001000	2
85	0010010010010000	2	0010010010010000	2	0100010001001001	1	0100010001001001	1
86	0000000100000100	2	0100001000100100	2	1000100001000100	2	0100001000100100	2
87	0000000100100100	2	0100010001000100	2	1000100010001000	2	0100010001000100	2

Annex H (normative)

Optimum Power Control and Recording Conditions

H.1 Optimum writing power

The optimum recording power P_{wo} that should be used for recording a disk is dependent on the disk, the recorder and the recording speed.

For the disk there are three main parameters involved:

- The sensitivity of the recording layers to laser power at a given wavelength.
- The change in sensitivity when the laser wavelength is changed.
- The “pit-formation mechanism” in the recording layer, which is dependent on the applied layer technology.

For the recorder the three main parameters involved are:

- The dimensions and optical quality of the laser light spot at the recording layer.
- The applied write strategy.
- The actual wavelength of the laser when recording the disk (see Annex J).
This wavelength depends on e.g.:
 - the type of laser,
 - the spread in wavelength for each individual laser of this type (and so for each individual recorder),
 - the actual write power,
 - the temperature of the laser.

As the optimum writing power P_{wo} depends on the disk, the recorder and the recording speed that are actually used, this power should be determined for each recorder/disk combination at the actual recording speed. Such a determination of the actual optimum writing power P_{wo} is called an **Optimum Power Control** procedure (OPC procedure).

H.1.1 Asymmetry and optimum writing power

For different writing powers, the asymmetry of the recorded 8-to-16 modulated data is different.

By test recording random 8-to-16 modulated data with different writing powers, and measuring the resulting asymmetry in the HF signal, the optimum writing power for the specific combination of disk and recorder at a specific recording speed can be obtained.

Figure H.1 shows schematically the procedure with the OPC and write strategy. The main signals that are influenced by the applied write strategy and power level are the modulation, the asymmetry and the jitter. In practice the asymmetry appears to be a sensitive parameter for OPC. An easier to handle alternative for the asymmetry is β .

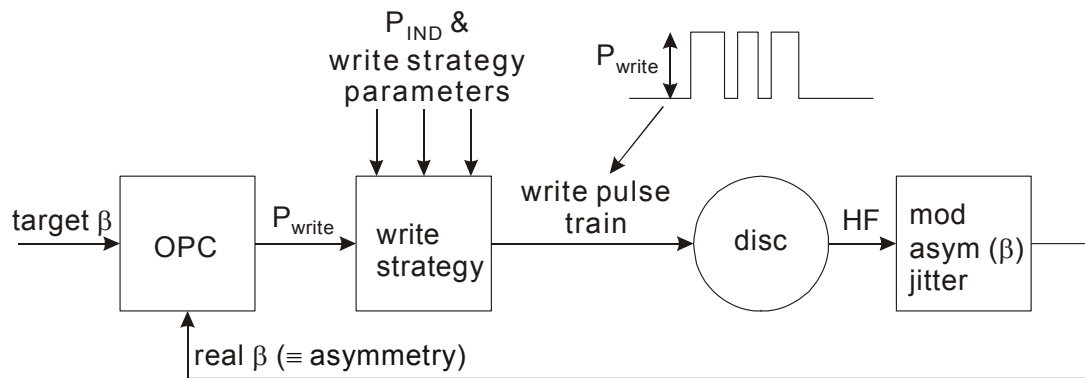

Figure H.1 - Schematical diagram of OPC procedure

H.1.2 Measurement of asymmetry by means of β

Using the definition of asymmetry directly, may result in complicated recorder electronics. Therefore a different parameter is used as a representation of asymmetry. This parameter β is based on using the AC coupled HF signal before equalization.

By definition: $\beta = (A_1 + A_2)/(A_1 - A_2)$ as the difference between the peak levels A_1 and A_2 ($A_1 + A_2$), normalized to the peak-peak value ($A_1 - A_2$) of the HF signal. See Figure H.2.

β defined in this way, will be approximately equal to the asymmetry.

Zero asymmetry of the measured HF signal will, in general, correspond to $\beta \approx 0$.

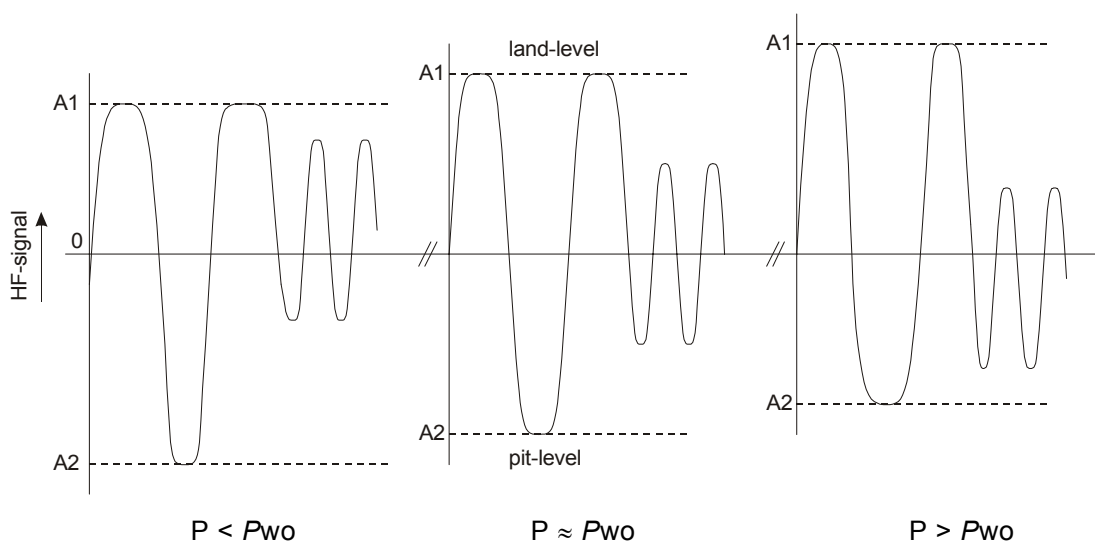

Figure H.2 - AC-coupled HF signals recorded with different writing powers

H.2 The OPC procedure

To facilitate the OPC procedure, an indicative value (an estimation) for the writing power is given at several writing speeds (see 14.4.2).

These values can not be used as the exact optimum writing power for the actual disk/recorder/speed combination, but can be used as a starting value for an OPC procedure.

As the setpoint in the OPC procedure, the target β value indicated in 14.4.2 is used.

The OPC procedure must be performed in an area on the disk that is specially reserved for this purpose: the Inner or Outer Disk Test Zone (see Table 6).

H.3 Write strategy parameters at other speeds

It is recommended that +R recorders compliant with this document use the indicated test speeds as follows:

- the Primary recording velocity indicates the lowest speed at which the disk has been verified for a specific write strategy,
- the Upper recording velocity indicates the highest speed at which the disk has been verified for a specific write strategy,

an estimate for the write parameters at any intermediate speed can be determined by linear interpolation between the parameters at the Primary recording velocity and the Upper recording velocity as indicated in 14.4.2.

NOTE

Disk Manufacturers should design media with a reasonable "linear" behaviour of the write strategy parameters over the speed range indicated in 14.4.2.

H.4 Media margins at non-optimum write power

To create some margins for practical accuracy requirements for drive implementations, the disk should allow for some deviations of the write power from the optimum values. Therefore the following specifications should be fulfilled (strongly recommended):

For actual write powers P_w in the range $0,90 \times P_{wo}$ to $1,05 \times P_{wo}$, and $P_b = P_{bo}$, the disk is recordable within all specifications.



Annex I (informative)

Light fastness of the disk

Light fastness of the +R disk should be tested with an air cooled Xenon lamp and test apparatus complying with ISO-105-B02.

Test conditions:

- Black Panel Temperature : < 40 °C
- Relative humidity: : 70 - 80 %

Disk illumination:

- Through the substrate, normal incident.
- Disk not packed, out of cassette.

Requirement:

All disk specifications must be fulfilled, after illumination with a Xenon lamp corresponding with the European Wool Reference #5 (see ISO-105-B02).

Remark:

The change in color of the +R disk is irrelevant for this test.

Annex J (informative)

Wavelength dependency

When organic dyes are used as a recording layer, the +R disk characteristics are fundamentally wavelength dependent ($\Delta P_{wo}/P_{wo}$ is typical 1 to 3.5 % per $\Delta\lambda = 1$ nm). On the other hand, the Laser Diode that generates the light used for recording and read-out of the +R disk has a wavelength with a certain tolerance. Moreover, the wavelength of the light emitted by the Laser Diode will depend on the temperature of the device.

This attachment intends to describe the tolerances in temperature and wavelength that are needed by the recorder. Furthermore the disk parameter $(dP/d\lambda)/(P/\lambda)$ is introduced which can speed up the recorder in determining the optimum write power under the recorder's specific conditions. This parameter shall be indicated in the Physical format information in ADIP (see 14.4.2).

J.1 Wavelength/Temperature behaviour of recorders

Figure J.1 shows a typical Wavelength/Temperature diagram which can be considered as operating conditions for the disk. The disk should comply with all specifications for the unrecorded and recorded disk within the operating conditions as defined by the shaded area in Figure J.1.

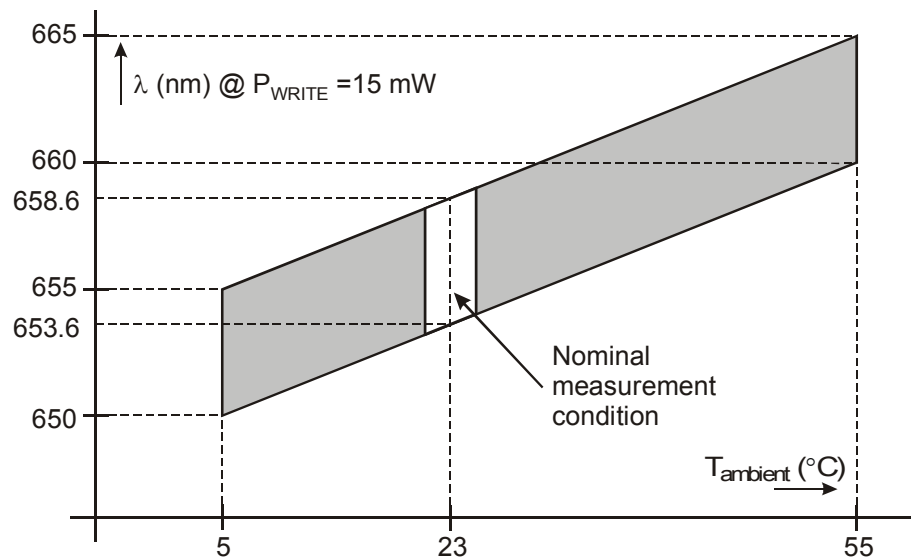

*Figure J.1 - Wavelength/Temperature diagram
indicating the disk operating conditions*

NOTE

The temperature of the Laser Diode itself may be higher than the ambient temperature of the disk due to dissipation in the laser. In the graph of Figure J.1, a constant temperature difference is assumed between the disk and the laser.

J.2 Write power / Wavelength dependency of the disk

In practice it is not easy to determine the write power dependency of the disk on the laser wavelength directly. What can be measured by using usual optical equipment is the absorption of the recording layer as a function of the wavelength. When assuming that the write power is inversely proportional to the absorption of the recording layer, the dependency of this absorption on the wavelength can be translated into a dependency of the write power on the wavelength.

J.2.1 Measurement of the absorption of the recording layer of the disk

The absorption of the recording (dye) layer of the disk is determined by measuring the reflection and transmission versus the wavelength. For this purpose a parallel beam is used at a small angle to the normal on the disk surface. The wavelength is controlled by means of a monochromator.

The measurements are performed on a mirror area at the inner side of the disk in order to prevent wavelength dependent diffraction of the light caused by grooved areas.

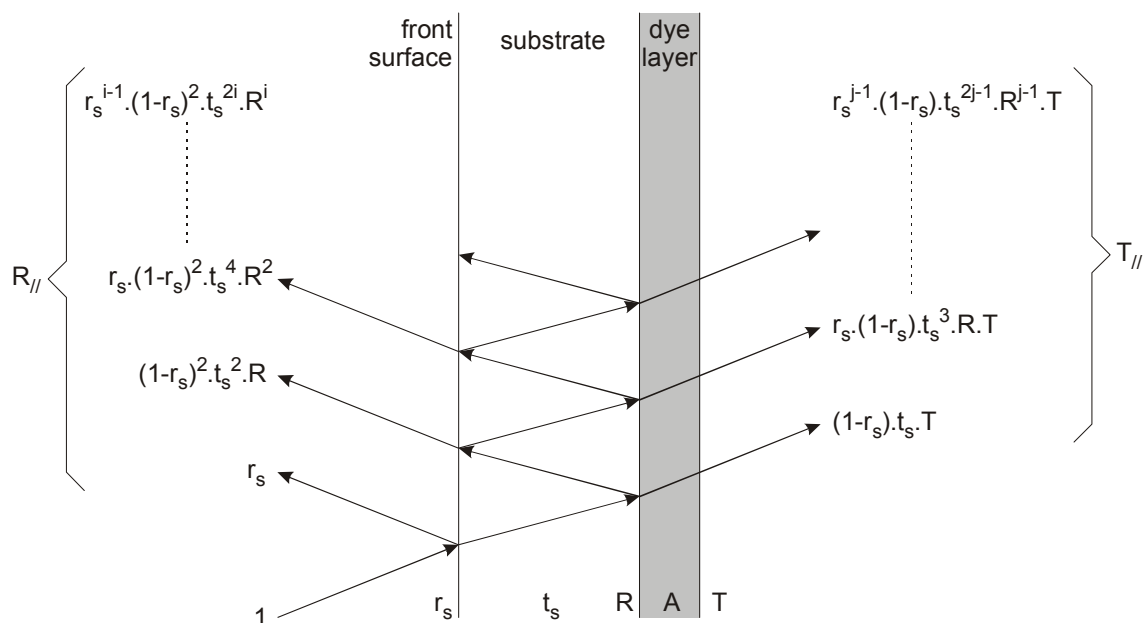

Figure J.2 – Definitions of reflectivity, transmission and absorption

In Figure J.2 the following applies:

for the transparency of the formulas, the intensity of the incident beam is assumed to be normalized to 1

r_s = reflectivity of the entrance surface

t_s = transmission of the substrate

R = reflectivity of the recording layer

A = absorption of the recording layer

T = transmission of the recording layer

$R_{//}$ = total measured reflected light

$T_{//}$ = total measured transmitted light

$$\text{From: } R_{//} = r_s + \frac{(1-r_s)^2 \cdot R \cdot t_s^2}{(1-r_s \cdot t_s^2 \cdot R)}$$

$$\text{the reflectivity of the dye can be calculated: } R = \frac{R_{//} - r_s}{(1+r_s \cdot R_{//} - 2 \cdot r_s) \cdot t_s^2}$$

$$\text{and from: } T_{//} = \frac{(1-r_s) \cdot t_s \cdot T}{1-r_s \cdot t_s^2 \cdot R} \text{ it follows that } T = T_{//} \cdot \frac{1-r_s \cdot t_s^2 \cdot R}{(1-r_s) \cdot t_s}$$

Because $A+T+R=1$, the absorption of the dye layer is given by: $A=1-R-T$

J.2.2 Determination of parameters for the Physical format information in ADIP

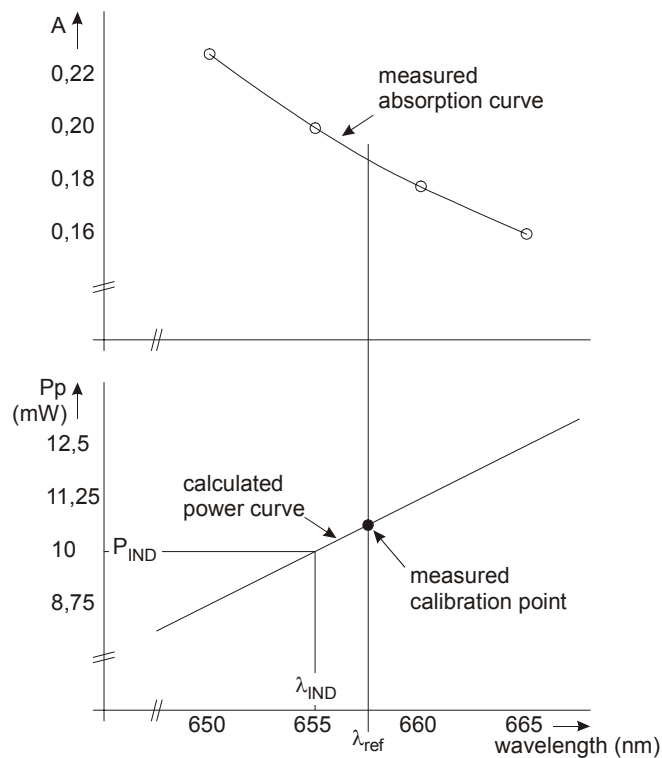

Figure J.3 – Example of absorption and power versus wavelength

The absorbed power $P_x = P_w(\lambda) \times A(\lambda)$ is creating the marks in the recording layer. It is assumed that this power P_x is more or less independent on the wavelength. In this case, $P_w(\lambda)$, a function of the wavelength λ , can be determined from $A(\lambda)$ with the help of the following formula:

$$P_w(\lambda) = \frac{P_w(\lambda_{ref}) \times A(\lambda_{ref})}{A(\lambda)}, \text{ in which } P_w(\lambda_{ref}) \text{ is the measured write power at } \lambda_{ref}.$$

The parameter $n = (dP_w/d\lambda)/(P_{IND}/\lambda_{IND})$ to be recorded in the Physical format information in ADIP can be determined from the power curve. $dP_w/d\lambda$ shall be averaged over the wavelength range from 645 nm to 670 nm. λ_{IND} has been chosen to be 655 nm and P_{IND} shall be $P_w(\lambda_{IND})$ as determined from the calculated power curve.

The parameter $(dP_w/d\lambda)/(P_{IND}/\lambda_{IND})$ is in principal speed independent.

J.2.3 Determination of start power for the OPC procedure in a specific recorder

The corrected power indication P_{cor} at the actual wavelength of the recorder λ_{actual} can be approximated by:

$$P_{\text{cor}}(\lambda_{\text{actual}}) = P_{\text{IND}} + \frac{dPw}{d\lambda} \times (\lambda_{\text{actual}} - \lambda_{\text{IND}}),$$

in which as well P_{IND} as $dPw/d\lambda$ are speed dependent.

The value of $dPw/d\lambda$ at a speed $v1$ can be calculated from the values specified in ADIP:

$$\left(\frac{dPw}{d\lambda} \right)_{\text{at } v1} = \frac{n}{\lambda_{\text{IND}}} \times P_{\text{IND at } v1}$$

The optimum start value of the power for the OPC procedure at a speed $v1$ can now be determined by the following formula:

$$P_{\text{start at } v1}(\lambda_{\text{actual}}) = P_{\text{IND at } v1} + \frac{n \times P_{\text{IND at } v1}}{\lambda_{\text{IND}}} \times (\lambda_{\text{actual}} - \lambda_{\text{IND}})$$

Annex K (informative)

Running OPC

The correct writing power for the +R disk is to be determined by means of an Optimum Power Calibration procedure as described in Annex H of this document. However, after this calibration, the optimum power may change because of:

- power sensitivity fluctuation over the disk,
- wavelength shift of the laser diode due to change in operating temperature,
- change of spot aberrations due to change in disk skew, substrate thickness, defocus, etc.,
- changed conditions of disk and/or optics, when OPC was carried out a long time before actual recording.

The purpose of a Running OPC is to actively monitor the mark formation process and continuously adjust the writing power to the optimum power that is required. During the OPC procedure, also a “Running OPC signal” may be obtained that can be associated with optimally written marks (for example using the instantaneously reflected light signal). Such a “Running OPC signal” can be used to maintain subsequent recordings at the same optimal level as that determined by the OPC procedure.



Annex L (informative)

Transportation

L.1 General

As transportation occurs under a wide range of temperature and humidity variations, for differing periods, by many methods of transport and in all parts of the world, it is not practical to specify mandatory conditions for transportation or for packaging.

L.2 Packaging

The form of packaging should be agreed between sender and recipient or, in absence of such an agreement, is the responsibility of the sender. It should take into account the following hazards.

L.2.1 Temperature and humidity

Insulation and wrapping should be designed to maintain the conditions for storage over the estimated period of transportation.

L.2.2 Impact loads and vibrations

- a) Avoid mechanical loads that would distort the shape of the disk.
- b) Avoid dropping the disk.
- c) Disks should be packed in a rigid box containing adequate shock-absorbent material.
- d) The final box should have a clean interior and a construction that provides sealing to prevent the ingress of dirt and moisture.



Annex M (informative)

Measurement of the groove wobble amplitude

M.1 Relation between wobble signal and wobble amplitude

The wobble amplitude in nm cannot easily be measured directly. However, it can be derived from the normalized wobble signal. The theoretical results for such a derivation are given below.

The peak value of the wobble signal I_W can be seen as:

$$I_{Wp} = A \times \sin(2 \times \pi \times a / p)$$

where:

a = wobble amplitude in nm

p = track pitch of the radial error signal

A = the peak value of the radial error signal

In Figure M.1 the parameters a , p , A and I_{Wp} are shown. The groove has a peak displacement of ' a ' (wobble amplitude) from the averaged centre of the groove to the actual centre of the groove. The normalized wobble signal can now be defined as:

$$\frac{I_{Wpp}}{(I_1 - I_2)_{pp}} = \frac{2 \times I_{Wp}}{2 \times A} = \sin\left(2 \times \pi \times \frac{a}{p}\right)$$

where

$$(I_1 - I_2)_{pp} = 2 \times A$$

The wobble signal I_W is not only dependent on the wobble amplitude a , but also the track pitch p . Due to normalization, dependencies on groove geometry, spot shape and optical aberrations have been eliminated.

M.2 Tolerances of the normalized wobble signal

From the above formulae for the normalized wobble signal, the tolerances as given in 28.4 can be converted to nm for a given track pitch of ' p ' = 0,74 μm .

Lower limit: 0,15 corresponds to a = 18 nm.

Upper limit: 0,25 corresponds to a = 30 nm.

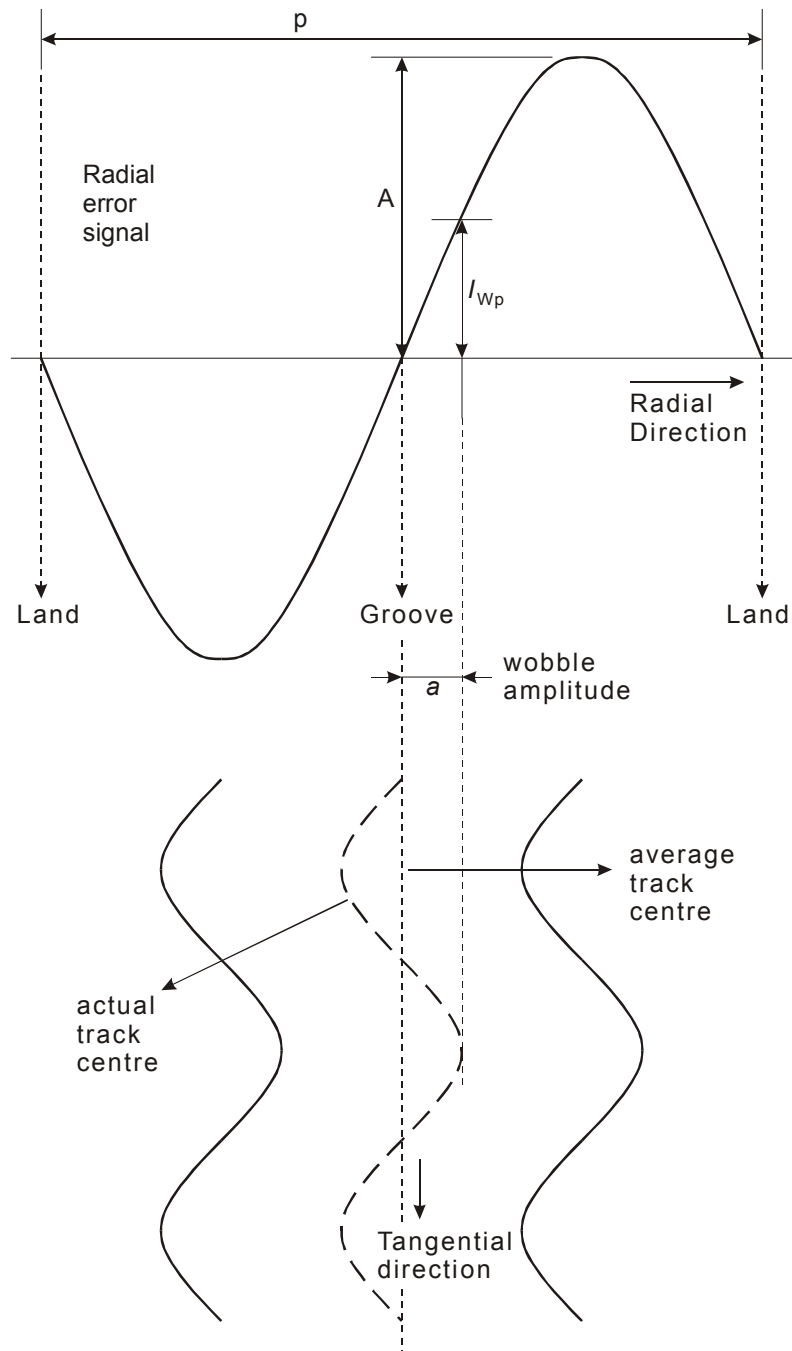

Figure M.1 - Wobble amplitude of the groove

Annex N (informative)

How to use the Physical format information in ADIP

To fully exploit the Physical format information in the ADIP, the following rules are given as a recommended guideline (see also the flowchart in Figure N.1).

Drives should read the ADIP and check for the following information:

- 1) check the Disk Category in byte 0
 - ⇒ determine if the disk is a +R or +RW disk; use the related book for further interpretations.

Drives shall respect the Disk Application Code:

- 2) check the Disk Application Code in byte 17
 - ⇒ if the drive is not able to obey the rules related to a specific Disk Application Code, the drive shall block the disk for recording.

If the drive can do "media recognition" (i.e. the drive can uniquely determine the manufacturer and the type of the disk and has optimum sets of write parameters for certain disks in its memory):

- 3) check for Disk Manufacturer and Media type ID (bytes 19 to 29)
 - ⇒ choose the optimum write strategy for this specific media from the drive's memory.

If the drive fails to recognize the media:

- 4) check the version number in byte 0
 - ⇒ if the version number is unknown: do not use the contents of bytes 32 to 63,
 - ⇒ if the version number is known: interpret bytes 32 to 63 according to the correct book version.
- 5) check byte 18 for the presence of Extended Information blocks
 - ⇒ if no EI blocks are present: only basic write strategy is available.

If EI blocks present:

- 6) check the format number in each present EI block
 - ⇒ if the format number is unknown: do not use the contents of the related EI block,
 - ⇒ if the format number is known: interpret the EI block according to the correct book version.

Now the drive can choose the best fitting recording speed and write strategy from the available options:

- ⇒ basic write strategy (1x ~ 2,4x) as defined in bytes 32 to 63,
- ⇒ write strategy from one of the known EI blocks,
- ⇒ for each available write strategy the drive should check the actually supported recording speeds indicated in the related bytes (supported recording speeds can be adapted in future versions of this document).

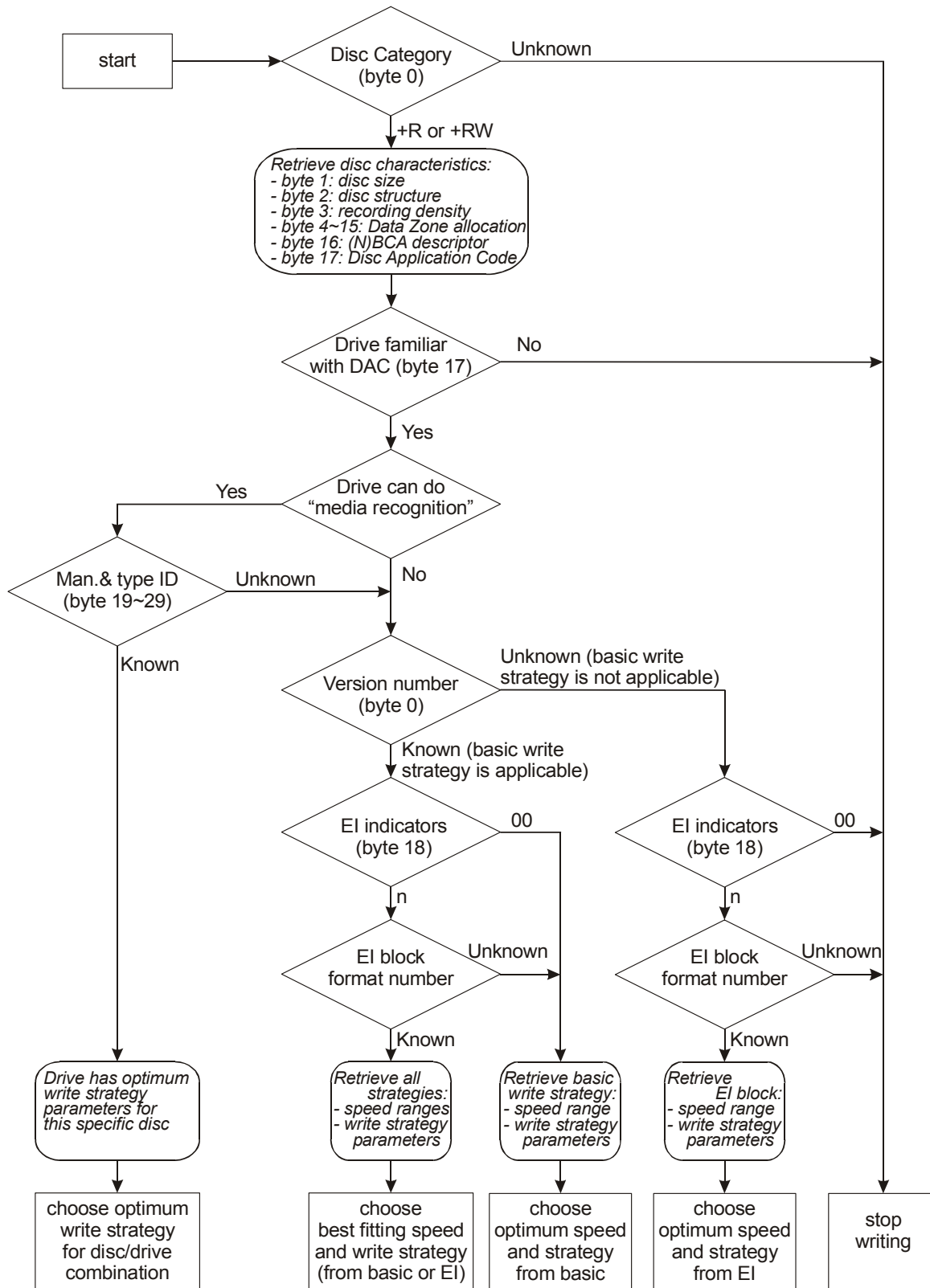

Note: in future more than one EI block can exist on one disc!

Figure N.1 - Flowchart showing the use of Physical format information in ADIP

Annex O (informative)

Values to be Implemented in Existing and Future Specifications

The values for bytes which this Ecma Standard specifies are related to Recordable disks which are in conformance with this Ecma Standard, viz. +R Format disks. It is expected that other categories of disks will be standardized in future. It is therefore recommended that the following values be used for these other disks. Further possible bit patterns are intended for future standardization.

All standards are subject to revisions, so the information in this Annex can be subject to changes. Therefore it is recommended to check this information against the most recent edition of the indicated standards.

Identification Data

- Bit b_{31} shall be set to
ZERO, indicating CLD format
ONE, indicating Zoned format
- Bit b_{30} shall be set to
ZERO, indicating pit tracking
ONE, indicating groove tracking
- Bit b_{29} shall be set to
ZERO if the reflectivity is greater than 40 % with a PBS optical system
ONE if the reflectivity is less than 40 % max. with a PBS optical system
- Bit b_{28} Reserved, shall be set to ZERO
- Bits b_{27} to b_{26} shall be set to
ZERO ZERO in the Data Zone
ZERO ONE in the Lead-in Zone
ONE ZERO in the Lead-out Zone
ONE ONE in the Middle Zone
- Bit b_{25} shall be set to
ZERO, indicating read-only data
ONE, indicating other than read-only data
- Bit b_{24} shall be set to
ZERO on Layer 0 of DL disks,
One on Layer 1 of DL disks,
ZERO on SL disks.
- Bits b_{23} to b_0 shall specify the Physical Sector Number

Physical format information in the ADIP in the Lead-in Zone

Byte 0 - Disk Category and Version Number

Bits b_7 to b_4 shall specify the Disk Category

- if set to 0000, they indicate a DVD - Read-Only disk
- if set to 0001, they indicate a DVD Rewritable disk (DVD-RAM)
- if set to 0010, they indicate a DVD-Recordable disk (DVD-R)

if set to 0011, they indicate a DVD Re-recordable disk (DVD-RW)
if set to 1001, they indicate a +RW disk
if set to 1010, they indicate a +R disk

Bits b_3 to b_0 shall specify the Version Number. Together with b_7 to b_4 they specify the related document.

if b_7 to b_4 set to 0000 and b_3 to b_0 set to 0001, they specify ECMA Standard 267/268
if b_7 to b_4 set to 0001 and b_3 to b_0 set to 0001, they specify ECMA Standard 272
if b_7 to b_4 set to 0001 and b_3 to b_0 set to 0110, they specify ECMA Standard 330
if b_7 to b_4 set to 0010 and b_3 to b_0 set to 0001, they specify ECMA Standard 279
if b_7 to b_4 set to 0011 and b_3 to b_0 set to 0010, they specify ECMA Standard 338
if b_7 to b_4 set to 1001 and b_3 to b_0 set to 0001, they specify ECMA Standard 274
if b_7 to b_4 set to 1001 and b_3 to b_0 set to 0010, they specify ECMA Standard 337
if b_7 to b_4 set to 1010 and b_3 to b_0 set to 0001, they specify this document

Byte 1 - Disk size and maximum transfer rate

Bits b_7 to b_4 shall specify the disk size

if set to 0000, they specify a 120 mm disk
if set to 0001, they specify an 80 mm disk

Bits b_3 to b_0 shall specify the maximum transfer rate

if set to 0000, they specify a maximum transfer rate of 2,52 Mbits/s
if set to 0001, they specify a maximum transfer rate of 5,04 Mbits/s
if set to 0010, they specify a maximum transfer rate of 10,08 Mbits/s
if set to 1111, they specify no maximum transfer rate is specified.

Byte 2 - Disk structure

Bit b_7 shall be set to ZERO.

Bits b_6 and b_5 shall specify the disk Type

if set to 00, they specify a single recording layer per side
if set to 01, they specify two recording layers per side

Bit b_4 shall be set to ZERO

Bits b_3 to b_0 specify the layer type

Bit b_3 shall be set to ZERO

Bit b_2 if set to
ZERO, shall specify that the disk does not contain re-writable Data Zones
ONE, shall specify that the disk contains re-writable Data Zones

Bit b_1 if set to
ZERO, shall specify that the disk does not contain recordable Data Zones
ONE, shall specify that the disk contains recordable Data Zones

Bit b_0 if set to
ZERO, shall specify that the disk does not contain embossed Data Zones
ONE, shall specify that the disk contains embossed Data Zones

Byte 3 - Recording density

Bits b_7 to b_4 shall specify the average Channel bit length

if set to 0000, they specify 0,133 μm
if set to 0001, they specify 0,147 μm
if set to 0010, they indicate that this average length is in the range 0,205 μm to 0,218 μm
if set to 1000, they specify 0,176 37 μm

Bits b_3 to b_0 shall specify the average track pitch

if set to 0000, they indicate a track pitch of 0,74 μm
if set to 0001, they indicate a track pitch of 0,80 μm

