

**Standard** ECMA-377

1<sup>st</sup> Edition / May 2007

**Information Interchange  
on Holographic Versatile  
Disc (HVD) Recordable  
Cartridges – Capacity:  
200 Gbytes per Cartridge**

**Standard**



is the registered trademark of Ecma International



**COPYRIGHT PROTECTED DOCUMENT**

Standard  
ECMA-377

1<sup>st</sup> Edition / May 2007

---

**Information Interchange on  
Holographic Versatile Disc  
(HVD) Recordable  
Cartridges – Capacity: 200  
Gbytes per Cartridge**

---



## **NOTIFICATION AND DISCLAIMER**

Ecma international draws attention to the possibility that the practice, use or implementation of this Ecma Standard or of parts thereof may involve the use of one or more Intellectual Property Rights, in particular such as a patent or a patent application.

Ecma International takes no position concerning the existence, evidence, scope of protection, validity or applicability of any or all of such Intellectual Property Rights, whether asserted by Ecma International members or others outside of the Ecma Standard development process worldwide. In particular, Ecma International does not identify any or all of such Intellectual Property Rights, does not evaluate the scope of protection and validity of any or all of such Intellectual Property Rights, and does not evaluate the question whether the practice, use or implementation of this Ecma Standard or of parts thereof does or does not make use of any or all of such Intellectual Property Rights. Furthermore, Ecma International does not assume – under any circumstances – any responsibility in this respect.

Ecma International informs that as of the date of approval of this Standard, Ecma International has received notice of Intellectual Property Rights. Implementers and users are cautioned that this may not represent the latest information which is available and are therefore strongly urged to consult the Ecma International website for further information.

---



## Introduction

In October 2004 a group of Companies, known as the HVD Alliance, proposed to Ecma to develop a standard for the first member of a family of holographic media. Ecma adopted this project and Ecma Technical Committee TC44 was established for the standardization of holographic media.

This Standard ECMA-377 is the first standard for a Holographic Disk Cartridge (HDC).

This Ecma Standard has been adopted by the General Assembly in May 2007.

---





## Table of contents

<b>Section 1</b>	<b>General</b>	<b>1</b>
<b>1</b>	<b>Scope</b>	<b>1</b>
<b>2</b>	<b>Conformance</b>	<b>1</b>
2.1	Holographic Disk Cartridge	1
2.2	Generating system	1
2.3	Receiving system	1
2.4	Compatibility statement	1
<b>3</b>	<b>References</b>	<b>2</b>
<b>4</b>	<b>Definitions</b>	<b>2</b>
4.1	asymmetry	2
4.2	case	2
4.3	case reference plane	2
4.4	clamping zone	2
4.5	cover layer	2
4.6	Data Page	2
4.7	Data Page hologram	2
4.8	Data Page hologram pitch	2
4.9	data reading beam	2
4.10	data reading energy	2
4.11	data recording beam	2
4.12	data recording energy	2
4.13	disk reference plane	3
4.14	entrance surface	3
4.15	Error Correction Code (ECC)	3
4.16	finalizing	3
4.17	fixing	3
4.18	format	3
4.19	hologram track	3
4.20	holographic disk	3
4.21	Holographic Disk Cartridge (HDC)	3
4.22	holographic recording	3
4.23	packet	3
4.24	Permanent holographic information (Phi) type (of medium)	3

4.25	pit	3
4.26	pit layer	3
4.27	pit track	3
4.28	pixel	3
4.29	recording layer	4
4.30	Reference Drive	4
4.31	Reference Pattern	4
4.32	Reed-Solomon code	4
4.33	spatial light modulator	4
4.34	Specific Disk Information (SDI)	4
4.35	spindle	4
4.36	Sub-Page	4
4.37	substrate	4
4.38	Symbol	4
4.39	Sync Mark	4
4.40	track	4
4.41	tracking/addressing beam	4
4.42	tracking/addressing reading power	4
4.43	track pitch	4
4.44	User data Zone	4
4.45	write-inhibit hole	5
4.46	zone	5
<b>5</b>	<b>Conventions and notations</b>	<b>5</b>
5.1	Representation of numbers	5
5.2	Names	5
<b>6</b>	<b>Acronyms</b>	<b>5</b>
<b>7</b>	<b>General description</b>	<b>5</b>
<b>8</b>	<b>General requirement</b>	<b>6</b>
8.1	Environments	6
8.1.1	Operating environment	6
8.1.2	Storage environment	6
8.1.3	Transportation	7
8.2	Temperature shock	7
8.3	Safety requirements	7
8.4	Flammability	7

<b>9</b>	<b>Reference Drive</b>	<b>7</b>
9.1	Optical system	7
9.2	Tracking and Addressing Channel	9
9.2.1	Tracking/addressing beam	9
9.2.2	Tracking/Addressing/SDI signals	9
9.3	Data Holographic Recording Channel	9
9.3.1	Recording beam	9
9.3.2	Spatial light modulator	10
9.4	Data Holographic Reading Channel	11
9.4.1	Read beam	11
9.4.2	Spatial light modulator	12
9.4.3	Photodetector array	12
9.5	Conditions for measuring the operational signals	12
9.5.1	Tracking, Addressing, Specific Disk Information	12
9.5.2	Data recording	12
9.5.3	Data reading	12
9.5.4	Normalized servo transfer functions	12
9.5.5	Rotation of the disk	12
9.6	Fixing	12
	<b>Section 2 - Mechanical and physical characteristics</b>	<b>13</b>
<b>10</b>	<b>Dimensional, mechanical, and physical characteristics of the case</b>	<b>13</b>
10.1	General description of the case	13
10.2	Reference axes and case reference plane	13
10.3	Case drawings	13
10.4	Dimensions of the case	13
10.4.1	Overall dimensions	13
10.4.2	Location hole	14
10.4.3	Alignment hole	14
10.4.4	Surfaces on Case Reference Plane P	15
10.4.5	Insertion slots and detent features	15
10.4.6	Gripper slots	16
10.4.7	Write-inhibit hole	16
10.4.8	Media identification sensor areas	16
10.4.9	Head and motor windows	17
10.4.10	Shutter	17
10.4.11	Shutter unlocking levers	17
10.4.12	Slider for shutter opener	19
10.4.13	Feature to prevent insertion into UDO, MO and WO drives	19
10.4.14	User label areas	19
10.5	Mechanical characteristics	19
10.5.1	Materials	19
10.5.2	Mass	19

10.5.3	Edge distortion	19
10.5.4	Compliance	20
10.5.5	Shutter opening force	20
10.5.6	Levers unlocking forces	20
10.6	Light-proof characteristics	20
10.7	Drop test	20
10.8	Electro-static discharge test	20
<b>11</b>	<b>Dimensional, mechanical, and physical characteristics of the disk</b>	<b>34</b>
11.1	General description of the disk	34
11.2	Reference axis and plane of the disk	34
11.3	Dimensions of the disk	35
11.4	Clamping Zone	35
11.5	Mechanical characteristics	35
11.5.1	Material	35
11.5.2	Mass	35
11.5.3	Moment of inertia	35
11.5.4	Imbalance	35
11.5.5	Axial deflection	35
11.5.6	Axial acceleration	36
11.5.7	Radial runout	36
11.5.8	Radial acceleration	36
11.5.9	Tilt	36
11.6	Optical characteristics	37
11.6.1	Substrate	37
11.6.2	Metadata layer	37
11.6.3	Gap layer 1	37
11.6.4	Dichroic mirror layer	37
11.6.5	Gap layer 2	37
11.6.6	Holographic recording layer	37
11.6.7	Cover layer	37
11.6.8	Thicknesses of the stack of layers	37
11.6.9	Birefringence of the stack of layers	39
<b>12</b>	<b>Interface between cartridge and drive</b>	<b>39</b>
12.1	Clamping method	39
12.2	Tapered cone for disk clamping	39
12.3	Clamping force	39
12.4	Capture cylinder	39
12.5	Disk position in operating condition	39
<b>Section 3</b>	<b>Format of information</b>	<b>41</b>
<b>13</b>	<b>General description</b>	<b>41</b>

<b>14</b>	<b>Tracking and addressing information format / Specific Disk Information format</b>	<b>41</b>
14.1	Pit track pitch	41
14.2	Pit track format	41
14.2.1	Sector	41
14.2.2	Header	42
14.2.3	Sync	46
14.2.4	Tracking data	46
14.2.5	Land	47
14.3	Specific Disk Information (SDI)	47
14.3.1	SDI bytes encoding	47
14.4	Channel bits radial alignment	47
<b>15</b>	<b>Data information format</b>	<b>48</b>
15.1	Data Page holograms layout in the recording layer	48
15.1.1	Radial Data Page hologram pitch	48
15.1.2	Data Page hologram layout within tracks	48
15.1.3	Zones / Tangential Data Page hologram pitch / Number of Data Page holograms per Peapod	48
15.2	Data Page encoding	50
15.2.1	User data	50
15.2.2	Header	50
15.2.3	Footer	50
15.2.4	ECC	50
15.2.5	Scrambling	51
15.3	Digital to image conversion	52
15.3.1.	8 to 16 bits conversion	52
15.3.2	Symbol/Sub-Page	53
15.4	Data Page hologram - Reference Pattern	54
<b>16</b>	<b>Formatted Zone</b>	<b>55</b>
16.1	General description of the Formatted Zone	55
16.2	Content/usage of the Formatted Zone	55
16.2.1	Zone 0 – Lead-in Zone / Buffer Zone 1 / Test Zone / Buffer Zone 2	55
16.2.2	Zones 1 to 15 - User data Zone	55
16.2.3	Zone 16 - Lead-out Zone	56
<b>17</b>	<b>Finalizing</b>	<b>56</b>
<b>Section 4 - Characteristics of the tracking/addressing and SDI information</b>		<b>56</b>
<b>18</b>	<b>Method of testing</b>	<b>56</b>
18.1	Environment	56
18.2	Use of the Reference Drive	56

18.2.1	Optics and mechanics	56
18.2.2	Tracking/addressing beam power	56
18.2.3	Tracking requirements	56
18.3	Definition of signals	56
<b>19</b>	<b>Signal requirements</b>	<b>57</b>
19.1	Reflectivity	57
19.2	Normalized Push Pull signal	57
19.3	Modulation	58
19.4	Resolution	58
19.5	4Ttop modulation	58
19.6	Asymmetry	58
19.6.1	Asymmetry (4T - 2T)	58
19.6.2	Asymmetry (16T - 4T)	58
19.7	Jitter	58
19.8	Phase depth	58
<b>Section 5</b>	<b>Characteristics of the recording layer</b>	<b>59</b>
<b>20</b>	<b>Method of testing</b>	<b>59</b>
20.1	Environment	59
20.2	Reference Drive	59
20.2.1	Optics and mechanics	59
20.2.2	Data recording energy	59
20.2.3	Data reading energy	59
20.2.4	Tracking requirements	59
20.2.5	Relative positioning of the focus of the data recording/reading beam and the tracking/addressing beam	59
20.2.6	Data detection for testing purposes	59
20.3	Writing conditions	59
20.3.1	Write pulse	59
20.3.2	Write pulse energy determination	59
<b>21</b>	<b>Recording layer characteristics requirements</b>	<b>60</b>
<b>22</b>	<b>Holographic material characteristics</b>	<b>60</b>
22.1	Read energy damage	60
<b>Section 6</b>	<b>Characteristics of user data</b>	<b>60</b>
<b>23</b>	<b>User data – Method of testing</b>	<b>60</b>
23.1	Environment	60
23.2	Reference Drive	60

23.2.1	Optics and mechanics	60
23.2.2	Tracking/addressing reading power	60
23.2.3	Data energy	60
23.2.4	Tracking requirements	60
23.2.5	Relative positioning of the focus of the data reading beam and the tracking/addressing beam	60
23.2.6	Data detection for testing purposes	61
<b>24</b>	<b>Minimum quality of a Data Page</b>	<b>61</b>
<b>25</b>	<b>Data interchange requirements</b>	<b>61</b>
25.1	Tracking	61
25.2	User-written data	61
25.3	User-read data	61
<b>Annex A (normative)</b>	<b>Edge distortion test</b>	<b>63</b>
<b>Annex B (normative)</b>	<b>Compliance test</b>	<b>65</b>
<b>Annex C (normative)</b>	<b>Cartridge light-proof test</b>	<b>69</b>
<b>Annex D (normative)</b>	<b>Electro-static discharge test</b>	<b>71</b>
<b>Annex E (normative)</b>	<b>Measurement of light reflectance</b>	<b>73</b>
<b>Annex F (normative)</b>	<b>Measurement of birefringence</b>	<b>75</b>
<b>Annex G (normative)</b>	<b>Tapered cone for disk clamping</b>	<b>79</b>
<b>Annex H (normative)</b>	<b>Specific Disk Information</b>	<b>81</b>
<b>Annex I (normative)</b>	<b>ECC</b>	<b>85</b>
<b>Annex J (normative)</b>	<b>16 bits to Symbols conversion look-up table</b>	<b>89</b>
<b>Annex K (normative)</b>	<b>Finalizing data</b>	<b>105</b>
<b>Annex L (normative)</b>	<b>Tracking/Addressing and Data Reading Channels characteristics</b>	<b>107</b>
<b>Annex M (normative)</b>	<b>Asymmetry measuring definition</b>	<b>111</b>
<b>Annex N (informative)</b>	<b>Office environment</b>	<b>113</b>
<b>Annex O (informative)</b>	<b>Transportation</b>	<b>115</b>
<b>Annex P (informative)</b>	<b>Track deviation measurement</b>	<b>117</b>





## Section 1 - General

### 1 Scope

---

This Ecma Standard specifies the mechanical, physical, and optical characteristics of a Holographic Disk Cartridge (HDC) that employs holographic recording to enable data interchange between such disks.

The disk is of the Phi (Permanent holographic information) type providing for data once written to be read a multiplicity of times.

The 120 mm diameter disk has a nominal capacity of 200 Gigabytes.

This Ecma Standard specifies

- the conditions for conformance testing and the Reference Drive;
- the environments in which the cartridges are to be operated and stored;
- the mechanical, physical and dimensional characteristics of the cartridge so as to provide mechanical interchangeability between data processing systems;
- the format of the information on the disk, both embossed and user-written, including the physical disposition of the tracks and data pages, the error correction codes, the modulation methods used;
- the characteristics of the embossed information on the disk;
- the holographic characteristics of the disk, enabling processing systems to write and read data onto/from the disk;
- the minimum quality of user-written data on the disk, enabling data processing systems to read data from the disk.

This Ecma Standard provides for interchange between holographic disk drives. Together with a standard for volume and file structure, it provides for full data interchange between data processing systems.

### 2 Conformance

---

#### 2.1 Holographic Disk Cartridge

An HDC shall be in conformance with this Ecma Standard if it meets all mandatory requirements specified therein.

#### 2.2 Generating system

A system generating an HDC for interchange shall be in conformance with this Ecma Standard if it meets the mandatory requirements of this Ecma Standard.

#### 2.3 Receiving system

A system receiving an HDC for interchange shall be in conformance with this Ecma Standard if it is able to process any recording made on the cartridge according to 2.1.

#### 2.4 Compatibility statement

A claim of conformance with this Ecma Standard shall include a statement listing any other disk cartridge standard supported by the system for which conformance is claimed. This statement shall specify the number of the standard(s), including, where appropriate, the disk cartridge type(s), and whether support includes reading only or both reading and writing.

### 3 References

---

The following Standards contain provisions, which through reference in this text, constitute provisions of this Ecma Standard. At the time of publication, the editions indicated were valid. All standards are subjected to revision, and parties to agreements based on this Ecma Standard are encouraged to investigate the possibility of applying the most recent editions of the following Standards.

ECMA-287 (2002) Safety of electronic equipment

ECMA-328 (2001) Detection and measurement of chemical emissions from electronic equipment

### 4 Definitions

---

For the purpose of this Ecma Standard the following definitions apply.

#### 4.1 **asymmetry**

The deviation between the centre levels of signals generated by two distinct repeating pit and land patterns.

#### 4.2 **case**

The housing that protects the disk and facilitates disk interchange.

#### 4.3 **case reference plane**

A plane to which the dimensions of the case are referred.

#### 4.4 **clamping zone**

The annular part of the disk within which the clamping force is applied by the clamping device.

#### 4.5 **cover layer**

A transparent layer of the disk, which protects other layers.

#### 4.6 **Data Page**

A two-dimensional representation of data.

#### 4.7 **Data Page hologram**

A hologram storing a Data Page.

#### 4.8 **Data Page hologram pitch**

The distance between adjacent Data Page hologram centres in the recording layer, measured in the radial direction (radial Data Page hologram pitch) or in the tangential direction (tangential Data Page hologram pitch).

#### 4.9 **data reading beam**

The beam used to reconstruct the image stored in the recorded hologram.

#### 4.10 **data reading energy**

The optical energy, incident at the entrance surface of the disk, of the hologram reading beam.

#### 4.11 **data recording beam**

The beam used to record the hologram.

#### 4.12 **data recording energy**

The optical energy, incident at the entrance surface of the disk, of the hologram recording beam.

#### **4.13 disk reference plane**

A plane defined by the perfectly flat annular surface of an ideal spindle onto which the clamping zone of the disk is clamped, and which is normal to the axis of rotation.

#### **4.14 entrance surface**

The surface of the disk onto which the optical beams first impinge.

#### **4.15 Error Correction Code (ECC)**

An error-detecting code designed to correct certain kinds of errors in data.

#### **4.16 finalizing**

The operation after which no further recording is allowed.

#### **4.17 fixing**

The operation for deactivating the holographic recording material by the use of an illumination so that it is no longer sensitive to light.

#### **4.18 format**

The arrangement or layout of information on the disk. The annular area on the disk bearing the format is the Formatted Zone.

#### **4.19 hologram track**

Track in the recording layer that contains or may contain holograms.

#### **4.20 holographic disk**

A disk that will accept and retain information in the form of a holographic recording in a recording layer.

#### **4.21 Holographic Disk Cartridge (HDC)**

A device consisting of a case containing a holographic disk.

#### **4.22 holographic recording**

An optical recording using holograms.

#### **4.23 packet**

A group of bytes/bits processed together during data encoding/decoding.

#### **4.24 Permanent holographic information (Phi) type (of medium)**

A medium with a holographic recording layer, which can be fixed (see 4.17).

#### **4.25 pit**

A local depression used to store data information.

#### **4.26 pit layer**

A layer of the disk bearing pits.

#### **4.27 pit track**

Track in the pit layer that contains pits.

#### **4.28 pixel**

The smallest independent element of a Data Page.

An "On-pixel" is an illuminated pixel and an "Off-pixel" is a non-illuminated pixel.

#### **4.29 recording layer**

A layer of the disk in which data is written during manufacture and/or use. The recording layer may actually consist of a multiple layer stack of different materials or composite materials.

#### **4.30 Reference Drive**

A drive with well defined properties used to test conformance to the Standard of the write/read parameters of the disk.

#### **4.31 Reference Pattern**

A light pattern used to generate the Data Page hologram, and recover its image content.

#### **4.32 Reed-Solomon code**

An error detection and/or correction code which is particularly suited to the correction of errors that occur in bursts or are strongly correlated.

#### **4.33 spatial light modulator**

A light modulator used to modulate the intensity of a light beam following a two-dimensional pattern.

#### **4.34 Specific Disk Information (SDI)**

Manufacturing information recorded on the disk.

#### **4.35 spindle**

The part of the disk drive that contacts the disk.

#### **4.36 Sub-Page**

A subdivision of a Data Page.

#### **4.37 substrate**

A layer of the disk provided for mechanical support of other layers.

#### **4.38 Symbol**

An encoding data unit of Data Page.

#### **4.39 Sync Mark**

A pattern of data pixels used for synchronization of Page data.

#### **4.40 track**

A path that is followed by the focus of an optical beam during exactly one revolution of the disk.

#### **4.41 tracking/addressing beam**

The beam used to read the tracking/addressing information.

#### **4.42 tracking/addressing reading power**

The optical power, incident at the entrance surface of the disk, of the tracking/addressing beam.

#### **4.43 track pitch**

The distance between adjacent track centrelines, measured in a radial direction.

#### **4.44 User data Zone**

The zone of the disk intended for the recording of user data.

#### 4.45 write-inhibit hole

A hole in the case which, when detected by the drive to be open, inhibits write operations.

#### 4.46 zone

An annular area of the disk.

## 5 Conventions and notations

---

### 5.1 Representation of numbers

A measured value is rounded off to the least significant digit of the corresponding specified value. For instance, it implies that a specified value of 1,26 with a positive tolerance of + 0,01 and a negative tolerance of - 0,02 allows a range of measured values from 1,235 to 1,275.

Numbers in decimal notations are represented by the digits 0 to 9.

Numbers in hexadecimal notation are represented by the hexadecimal digits 0 to 9 and A to F in parentheses.

The setting of bits is denoted by ZERO and ONE.

Numbers in binary notations and bit patterns are represented by strings of digits 0 and 1, with the most significant bit shown to the left.

Negative values of numbers in binary notation are given as Two's complement.

In each field the data is recorded so that the most significant byte (MSB), identified as Byte 0, is recorded first and the least significant byte (LSB) last. In a field of  $8n$  bits, bit  $b_{(8n-1)}$  shall be the most significant bit (msb) and bit  $b_0$  the least significant bit (lsb). Bit  $b_{(8n-1)}$  is recorded first.

A binary digit which can be set indifferently to ZERO or to ONE is represented by "x".

### 5.2 Names

The names of entities, e.g. specific fields, areas, zones, etc. are given a capital initial.

## 6 Acronyms

---

ECC	Error Correction Code
HDC	Holographic Disk Cartridge
HVD	Holographic Versatile Disc
LDPC	Low Density Parity Check (code)
LSB	Least Significant Byte
lsb	least significant bit
MO	Magneto Optical
MSB	Most Significant Byte
msb	most significant bit
Phi	Permanent holographic information (type)
SDI	Specific Disk Information
Sync	Synchronization
UDO	Ultra Density Optical
WO	Write Once

## 7 General description

---

The Holographic Disk Cartridge, which is the subject of this Ecma Standard, consists of a case containing a holographic disk.

The case is a protective enclosure for the disk. It has access windows on each side covered by a shutter. The windows are automatically uncovered by the drive when the cartridge is inserted into it.

The holographic disk consists of a substrate bearing a stack of layers.

Data can be written onto the disk as holographic fringes in the volume of the recording layer, using a focused optical beam. Data can be read by a focused optical beam.

A layer of the disk contains tracking/addressing data carried by pre-embossed pits. This data can be read using the diffraction of a focused optical beam by the pits.

The beams access the recording and pit layers through the transparent cover layer of the disk.

## 8 General requirement

---

### 8.1 Environments

#### 8.1.1 Operating environment

The operating environment is the environment where air immediately surrounding the Holographic Disk Cartridge has the following properties:

##### 8.1.1.1 Operating environment for a Holographic Disk Cartridge before finalizing

Temperature	35 °C ± 2 °C
Atmospheric pressure	60 kPa to 106 kPa
Relative humidity	20 % to 60 %
Absolute humidity	25 g/m <sup>3</sup> max.
Ambient light	shutter close: 135 μW/cm <sup>2</sup> , shutter open (in drive): 1 nW/cm <sup>2</sup>
Air cleanliness	Office environment (see Annex N)

No condensation on or in the Holographic Disk Cartridge shall occur. If a Holographic Disk Cartridge has been exposed during storage and/or transportation to a condition outside the above values, before use the cartridge shall be conditioned in the operating environment for a time at least equal to the period during which it has been out of the operating environment, up to a maximum of 24 h.

##### 8.1.1.2 Operating environment for a Holographic Disk Cartridge after finalizing

Temperature	35 °C ± 2 °C
Atmospheric pressure	60 kPa to 106 kPa
Relative humidity	20 % to 80 %
Absolute humidity	25 g/m <sup>3</sup> max.
Ambient light	shutter close: 135 μW/cm <sup>2</sup> , shutter open (in drive): 1 nW/cm <sup>2</sup>
Air cleanliness	Office environment (see Annex N)

No condensation on or in the Holographic Disk Cartridge shall occur. If a Holographic Disk Cartridge has been exposed during storage and/or transportation to a condition outside the above values, before use the cartridge shall be conditioned in the operating environment for a time at least equal to the period during which it has been out of the operating environment, up to a maximum of 24 h.

#### 8.1.2 Storage environment

The Holographic Disk Cartridge without any protective enclosure shall not be stored in an environment outside the range allowed for storage. The storage environment is defined as an environment where the air immediately surrounding the Holographic Disk Cartridge has the following properties:

#### 8.1.2.1 Storage environment for a Holographic Disk Cartridge before finalizing

Temperature	16°C to 32 °C
Atmospheric pressure	60 kPa to 106 kPa
Relative humidity	20 % to 40 %
Absolute humidity	25 g/m <sup>3</sup> max.
Ambient light (shutter close)	135 μW/cm <sup>2</sup>
Air cleanliness	Office environment (see Annex N)

No condensation on or in the Holographic Disk Cartridge shall occur.

#### 8.1.2.2 Storage environment for a Holographic Disk Cartridge after finalizing

Temperature	16 °C to 32 °C
Atmospheric pressure	60 kPa to 106 kPa
Relative humidity	20 % to 80 %
Absolute air humidity	25g/m <sup>3</sup> max.
Ambient light (shutter close)	135 μW/cm <sup>2</sup>
Air cleanliness	Office environment (see Annex N)

No condensation on or in the Holographic Disk Cartridge shall occur.

#### 8.1.3 Transportation

This Ecma Standard does not specify requirements for transportation. Guidance for transportation is given in Annex O.

### 8.2 Temperature shock

The Holographic Disk Cartridge shall withstand a temperature shock of up to 10 °C when inserted into, or removed from, the drive.

### 8.3 Safety requirements

The cartridge shall satisfy the safety requirements of Standards ECMA-287 and ECMA-328, when used in the intended manner or in any foreseeable use in an information processing system.

### 8.4 Flammability

The cartridge and its components shall be made from materials that comply with the flammability class for HB materials, or better, as specified in Standard ECMA-287.

## 9 Reference Drive

---

The Reference Drive is a drive several critical components of which have well defined properties and which is used to test the write; read parameters of the disk for conformance to this Ecma Standard. This section gives an outline of all components; components critical for tests in specific sections are specified in those sections.

### 9.1 Optical system

The basic set-up of the optical system of the Reference Drive used for measuring the write and read parameters is shown in Figure 1a. Different components and locations of components are permitted, provided that the performance remains the same as that of the set-up in Figure 1a. The optical system shall be such that the detected light reflected from the entrance surface of the disk is minimized so as not to influence the accuracy of the measurements.

The combination of the polarizing beamsplitter PBS2 and quarter-wave plate separates the incident recording/reading beam and the recording/reading beam reflected from the holographic disk. The polarizing beamsplitter PBS2 shall have, at the recording/reading beam wavelength  $\lambda_R$ , a p-s intensity transmittance ratio of at least 1000 and s-p intensity reflectance ratio of at least 80.

The dichroic beamsplitter DBS shall have a reflectance of at least 99 % for the tracking/addressing wavelength  $\lambda_T$  and a transmittance of at least 98 % for the recording/reading wavelength  $\lambda_R$ .

The combination of the polarizing beamsplitter PBS1 and quarter-wave plate separates the incident tracking/addressing optical beam and the tracking/addressing beam reflected from the holographic disk. The polarizing beamsplitter PBS1 shall have, at the tracking/addressing beam wavelength  $\lambda_T$ , a p-s intensity reflectance ratio of at least 100.

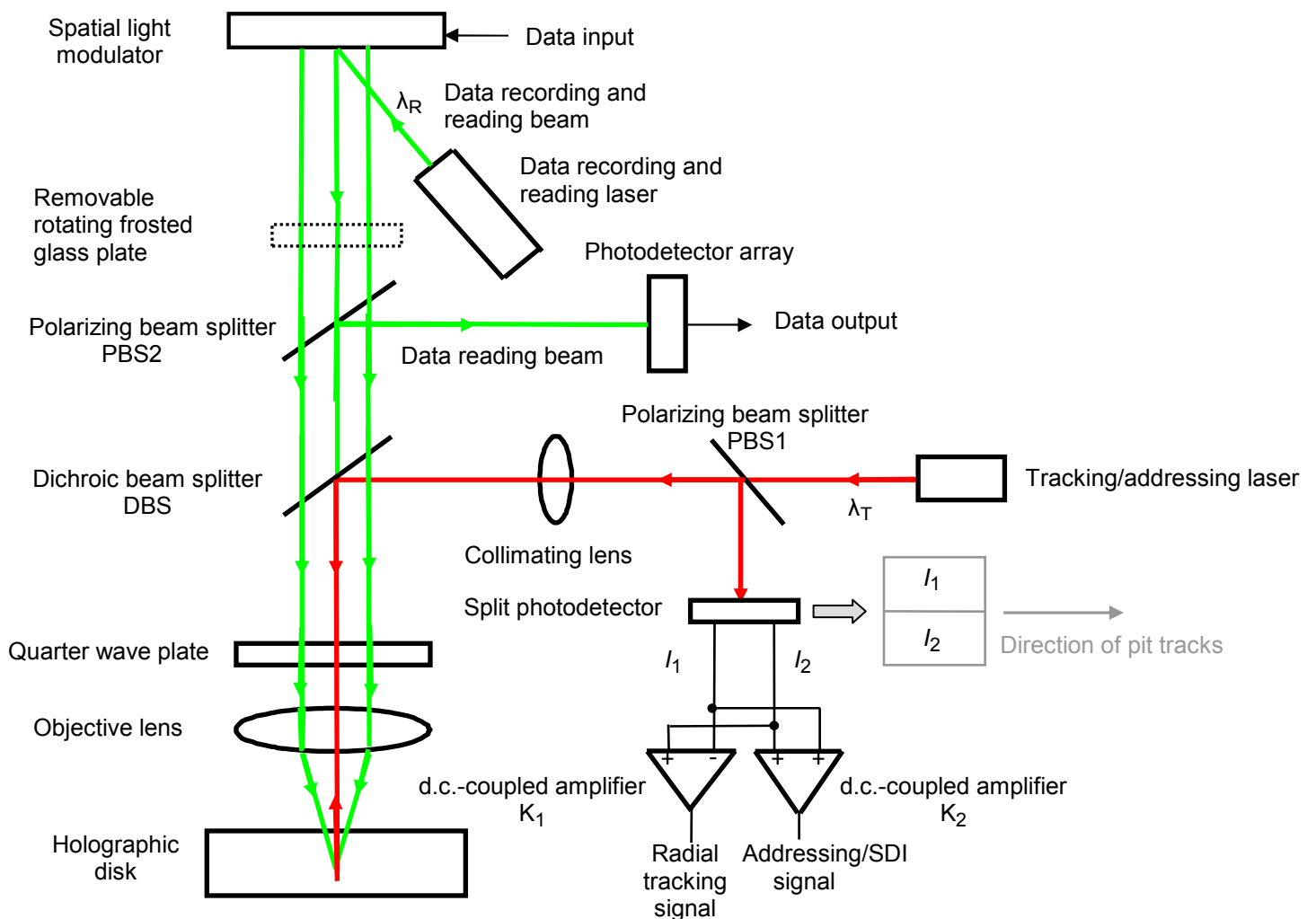

$\lambda_T$  : Wavelength of the tracking/addressing beam

$\lambda_R$  : Wavelength of the data recording/reading beam

$I_1, I_2$  : Output currents from the split photodetector

Figure 1a – Optical system of the Reference Drive



## 9.2 Tracking and Addressing Channel

The Tracking and Addressing Channel shall be used to generate tracking/addressing information and read manufacture Specific Disk Information (SDI).

### 9.2.1 Tracking/addressing beam

The laser beam used for tracking/addressing shall have the following characteristics.

Wavelength	655 nm
	+ 10 nm
	- 5 nm
Polarization	Circular
Focal length of objective lens	Such that to conform to 9.5.2 and 9.5.3 specifications
Numerical aperture	0,39 ± 0,01
Light intensity at the rim of the pupil of the objective lens	≥ 40% of the maximum intensity level in the radial direction, and ≥ 40% in the tangential direction
Wave front aberration from an ideal spherical wave front after passing through an ideal stack of disk layers	0,033 λ rms max.
Relative Intensity noise (RIN)	-126 dB/Hz max.

### 9.2.2 Tracking/Addressing/SDI signals

The method of generating the axial tracking error is not specified for the Reference Drive.

The radial tracking error signal shall be generated from the output currents of a split photodiode detector, the division of which runs parallel to the image of the pit tracks on the diode (see Figure 1a). The radial tracking error signal relates to the difference in the amount of light in the two halves of the exit pupil of the objective lens.

The amplifier  $K_1$  after the photodetector shall be d.c.-coupled with the bandwidth characteristics specified in Clause 18.

The addressing information signal is generated from the reading signal issued from the sum of the output currents of the split photodiode detector. The addressing information reading signal relates to the total amount of light in the exit pupil of the objective lens. The amplifier  $K_2$  after the photodetector shall be d.c.-coupled with the bandwidth characteristics specified in Clause 18.

The SDI signal shall be derived from the reading of the content of tracking data area of specific tracks, as specified in Clause 18.

## 9.3 Data Holographic Recording Channel

The Data Holographic Recording Channel shall be used to record the hologram of the Data Page image generated by the spatial modulator, which receives the data to be recorded.

### 9.3.1 Recording beam

The laser pulsed beam used for data recording shall have the following characteristics.

Wavelength	532,0 nm ± 0,1 nm
Polarization	Circular
Focal length of objective lens	5,000 mm ± 0,002 mm
Numerical aperture	0,50 ± 0,01

Light intensity at the rim of the pupil of the objective lens	$\geq 55\%$ of the maximum intensity level, in radial and tangential directions
Wave front aberration from an ideal spherical wave front after passing through an ideal stack of disk layers	0,012 $\lambda$ rms max.
Coherent length	$\geq 1,8$ mm
Laser pulse width	$< 50$ ns at half maximum
Laser pulse energy	as specified in SDI (see Annex H)

### 9.3.2 Spatial light modulator

The spatial light modulator shall comprise 358x358 elements that shall modulate the recording beam into a data image representing the data pattern to be recorded in form of hologram in the recording layer (See Figure 1b).

The hologram shall be constituted of fringes resulting of the interference of light issued of the modulated Data Page and light issued of the annular reference area around the Data Page (see 15.4).

The pitch of spatial modulator elements shall be  $13,68 \mu\text{m} \pm 0,02 \mu\text{m}$ .

Their fill factor shall be  $85,2\% \pm 0,1 \%$ .

The Modulation ratio of the On/Off pixels generated by the spatial light modulator shall be at least 500.

The relative positioning, in the spatial modulator plane, of the Data Page pattern versus the optical axis and spindle axis shall be as shown on Figures 1b and 1 c.

The orientation axis of the spatial modulator shall be disposed in direction of the spindle axis with a tolerance  $\alpha$  (see Figure 1c) better  $\pm 0,01^\circ$ .

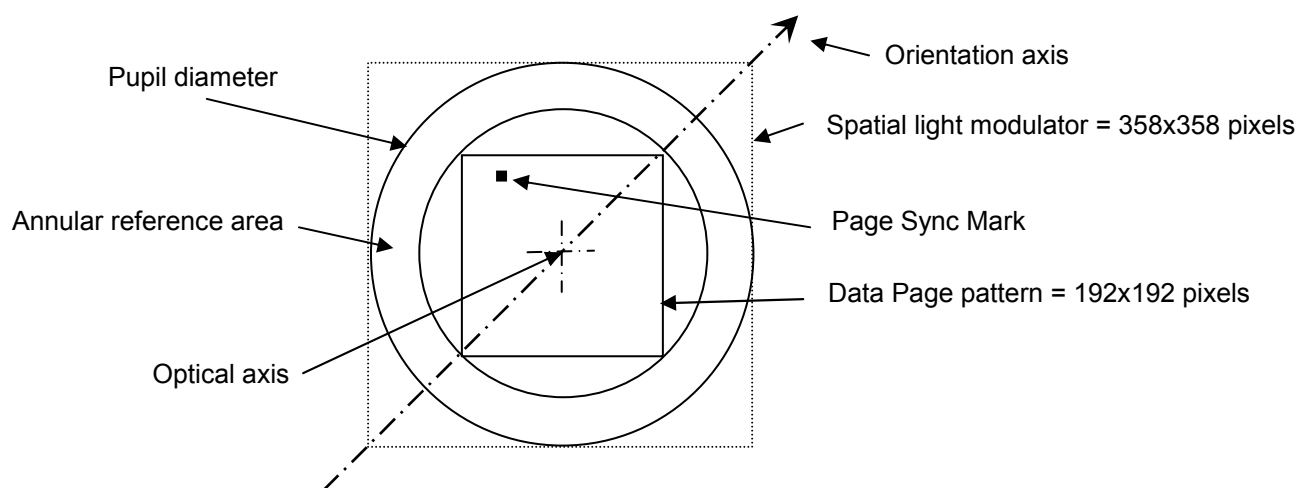

*Figure 1b – Position of the spatial light modulator versus the optical axis (seen from the incoming beam side)*

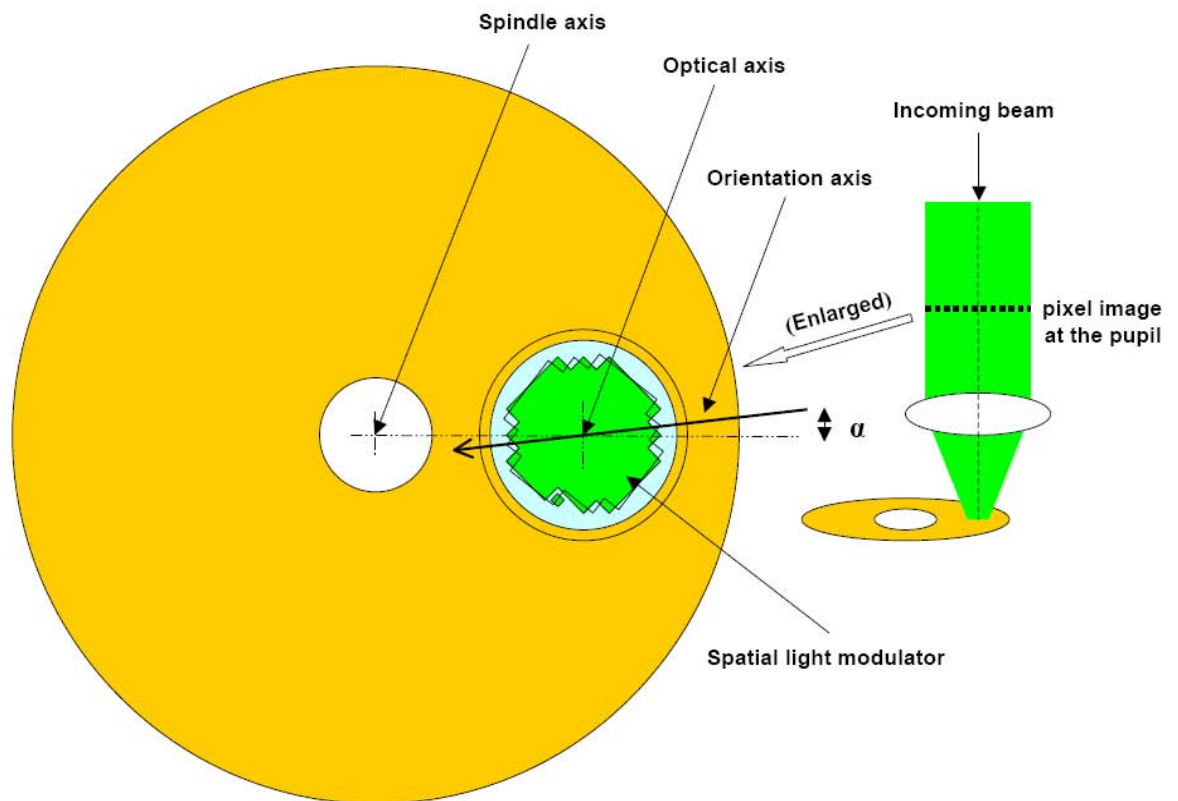

Figure 1c - Orientation of the spatial light modulator versus the spindle axis  
(seen from the incoming beam side)

## 9.4 Data Holographic Reading Channel

The Data Holographic Reading Channel shall be used to reconstitute the image from the recorded hologram and read back the recorded data.

### 9.4.1 Read beam

The pulsed laser beam used for data reading shall have the following characteristics.

Wavelength	532 nm $\pm$ 0,1 nm
Polarization	Circular
Focal length of objective lens	5,000 mm $\pm$ 0,002 mm
Numerical aperture	0,50 $\pm$ 0,01
Light intensity at the rim of the pupil of the objective lens	$\geq$ 55% of the maximum intensity level, in radial and tangential directions
Wave front aberration from an ideal spherical wave front after passing through an ideal stack of disk layers	0,012 $\lambda$ rms max.
Coherent length	$\geq$ 1,8 mm
Laser pulse width	< 50 ns at half maximum
Laser pulse energy	as specified in SDI (see Annex H)

#### 9.4.2 Spatial light modulator

During data reading the modulating elements of the spatial light modulator shall be in a state generating only the Reference Pattern beam (see 15.4).

#### 9.4.3 Photodetector array

The photodetector array shall be constituted of 576x576 elements that shall be used for the detection of data recorded in the Data Page.

The pitch of the elements shall be  $12,0 \mu\text{m} \pm 0,5 \mu\text{m}$ . The signal generated by each photodetector array element shall be linearly related to the energy received by this element during each reading pulse.

Data detection shall be performed as specified in Annex L.2.

### 9.5 Conditions for measuring the operational signals

#### 9.5.1 Tracking, Addressing, Specific Disk Information

During the measurement of the signals, the focus of the tracking/addressing beam shall have an axial deviation of not more than

$$e_{\text{max}}(\text{axial}) = 0,23 \mu\text{m}$$

from the pit layer, and it shall have a radial deviation of not more than

$$e_{\text{max}}(\text{radial}) = 0,022 \mu\text{m}$$

from the centre of the track.

#### 9.5.2 Data recording

During recording, the relative positioning of the centres of the focus of the data recording beam and the tracking/addressing beam shall be such that their axial distance shall be  $100 \mu\text{m} \pm 1 \mu\text{m}$ , and their radial and tangential misalignments shall be less than  $0,1 \mu\text{m}$ .

#### 9.5.3 Data reading

During reading, the relative positioning of the centres of the focus of the data reading beam and the tracking/addressing beam shall be such that their axial distance shall be  $100 \mu\text{m} \pm 1 \mu\text{m}$ , and their radial and tangential misalignments shall be less than  $0,1 \mu\text{m}$ .

#### 9.5.4 Normalized servo transfer functions

##### 9.5.4.1 Reference servo for axial tracking

The reference servo for axial tracking used for measurement of servo related parameters specifications shall be as specified in 11.5.6.

##### 9.5.4.2 Reference servo for radial tracking

The reference servo for axial tracking used for measurement of servo related parameters specifications shall be as specified in 11.5.8.

#### 9.5.5 Rotation of the disk

The spindle shall position the disk as specified in 12.5.

It shall rotate the disk at  $300 \text{ rpm} \pm 30 \text{ rpm}$ .

The direction of rotation of the disk shall be counter-clockwise when viewed from the objective lens.

### 9.6 Fixing

The fixing of an area of the disk shall be done by illumination of this area through a removable rotating frosted glass plate introduced, only during fixing, in the Recording Channel between the spatial light modulator and beam separator PBS2 (see Figure 1a).

The frosted glass shall be obtained by polishing with #1500 sand paper. It shall rotate at  $30 \text{ rpm} \pm 10 \text{ rpm}$ .

The pattern used to illuminate the disk shall be a Data Page with all pixels "On" (see 15.3), with energy as specified in the SDI (see Annex H).

## Section 2 - Mechanical and physical characteristics

### 10 Dimensional, mechanical, and physical characteristics of the case

---

#### 10.1 General description of the case

The case (see Figure 2) is a protective container of rectangular shape. It has windows on each side to allow the spindle of the drive to clamp the disk by its centre hole and to allow the head to access the disk. A shutter uncovers the windows upon insertion into the drive, and automatically covers them upon removal from the drive. The case has media identification, write-inhibit, mis-insertion features, detent for autoloading, gripper slots for an autochanger, label areas, and side identification inscriptions.

#### 10.2 Reference axes and case reference plane

There is a Case Reference Plane P on side A of the case. The Case Reference Plane P contains two orthogonal axes X and Y to which the dimensions of the case are referred. The intersection of the X and Y axes defines the centre of the location hole. The X-axis extends through the centre of the alignment hole.

#### 10.3 Case drawings

The case is represented schematically by the following drawings.

Figure 2 shows a composite drawing of Side A of the case in isometric form, with the major features identified from this side.

Figure 3 shows the envelope of the case with respect to a location hole at the intersection of the X and Y axes of Case Reference Plane P.

Figure 4 shows the surfaces S1, S2, S3 and S4 that establish the Case Reference Plane P located on side A.

Figure 4a shows the details of surface S3.

Figure 5 shows the details of the insertion slots and detents.

Figure 6 shows the gripper slots, used for automatic handling.

Figure 7 shows the write-inhibit hole.

Figure 8 shows the media identification sensor areas.

Figure 9 shows the head and motor windows.

Figure 10 shows the shutter opening features.

Figure 10a shows the locked/unlocked shutter levers configurations.

Figure 10b shows the shutter slider.

Figures 11a and 11b show the user label areas.

#### 10.4 Dimensions of the case

##### 10.4.1 Overall dimensions

The total length of the case (see Figure 3) shall be

$$L_1 = 153,0 \text{ mm} \pm 0,4 \text{ mm}$$

The distance from the top of the case to the reference axis X shall be

$$L_2 = 127,0 \text{ mm} \pm 0,3 \text{ mm}$$

The distance from the bottom of the case to the reference axis X shall be

$$L_3 = 26,0 \text{ mm} \pm 0,3 \text{ mm}$$

The total width of the case shall be

$$L_4 = 135,0 \text{ mm} \begin{array}{l} + 0,0 \text{ mm} \\ - 0,6 \text{ mm} \end{array}$$

The distance from the left-hand side of the case to the reference axis Y shall be

$$L_5 = 128,5 \text{ mm} \begin{array}{l} + 0,0 \text{ mm} \\ - 0,5 \text{ mm} \end{array}$$

The distance from the right-hand side of the case to the reference axis Y shall be

$$L_6 = 6,5 \text{ mm} \pm 0,2 \text{ mm}$$

The width shall be reduced on the top by the radius

$$R_1 = L_4$$

originating from a point defined by  $L_5$  and

$$L_7 = 101,0 \text{ mm} \pm 0,3 \text{ mm}$$

The two corners of the top shall be rounded with a radius

$$R_2 = 1,0 \text{ mm} \pm 0,5 \text{ mm}$$

and the two corners at the bottom with a radius

$$R_3 = 3,0 \text{ mm} \pm 0,5 \text{ mm}$$

The thickness of the case shall be

$$L_8 = 11,00 \text{ mm} \pm 0,30 \text{ mm}$$

The eight long edges of the case shall be rounded with a radius

$$R_4 = 1,0 \text{ mm max.}$$

#### 10.4.2 Location hole

The centre of the location hole (see Figure 3) shall coincide with the intersection of the reference axes X and Y. It shall have a square form with a side length of

$$L_9 = 4,10 \text{ mm} \begin{array}{l} + 0,00 \text{ mm} \\ - 0,06 \text{ mm} \end{array}$$

held to a depth of

$$L_{10} = 2,4 \text{ mm} \pm 0,2 \text{ mm}$$

The lead-in edges shall be rounded with a radius

$$R_5 = 0,5 \text{ mm max.}$$

#### 10.4.3 Alignment hole

The centre of the alignment hole (see Figure 3) shall lie on reference axis X at a distance of

$$L_{11} = 122,0 \text{ mm} \pm 0,2 \text{ mm}$$

from the reference axis Y.

The dimensions of the hole shall be

$$L_{12} = 4,10 \text{ mm} \begin{array}{l} + 0,00 \text{ mm} \\ - 0,06 \text{ mm} \end{array}$$

and

$$L_{13} = 5,0 \text{ mm} \begin{array}{l} + 0,2 \text{ mm} \\ - 0,0 \text{ mm} \end{array}$$

held to a depth of  $L_{10}$ .

The lead-in edges shall be rounded with radius  $R_5$ .

#### 10.4.4 Surfaces on Case Reference Plane P

The Case Reference Plane P (see Figure 4) located on Side A of the case shall contain four surfaces (S1, S2, S3 and S4) on that side of the case, specified as follows:

- Two circular surfaces S1 and S2:

Surface S1 shall be a circular area centred on the square location hole and have a diameter of

$$D_1 = 9,0 \text{ mm min.}$$

Surface S2 shall be a circular area centred on the rectangular alignment hole and have a diameter of

$$D_2 = 9,0 \text{ mm min.}$$

- Two elongated surfaces S3 and S4 that follow the contour of the case:

Surfaces S3 and S4 are shaped symmetrically on the two top sides of the case.

Surface S3 (see also Figure 4a) on the right hand side shall extend from a height defined by distance  $L_7$  from the reference axis X to

$$L_{14} = 26,0 \text{ mm} \pm 0,3 \text{ mm}$$

with a width of

$$L_{15} = 1,35 \text{ mm} \pm 0,2 \text{ mm}$$

and a right hand side boundary with radius

$$R_6 = 132,65 \text{ mm}$$

The top surface of the case shall not be higher than the Reference Plane on a width

$$L_{16} = 4,15 \text{ mm min.}$$

located at the left hand boundary of S3.

#### 10.4.5 Insertion slots and detent features

The case shall have two insertion slots with embedded detent features (see Figure 5). These slots shall be symmetrical relatively to the two sides of the case.

The slots shall have a length of

$$L_{17} = 44,0 \text{ mm} \pm 0,3 \text{ mm}$$

a width of

$$L_{18} = 6,0 \text{ mm} \begin{array}{l} + 0,3 \text{ mm} \\ - 0,0 \text{ mm} \end{array}$$

and a depth of

$$L_{19} = 3,0 \text{ mm} \pm 0,1 \text{ mm}$$

located

$$L_{20} = 2,5 \text{ mm} \pm 0,2 \text{ mm}$$

from Case Reference Plane P.

The slots shall have a lead-in chamfer given by

$$L_{21} = 0,5 \text{ mm max.}$$

$$L_{22} = 5,0 \text{ mm max.}$$

The detent notch shall be a semi-circle of radius

$$R_7 = 3,0 \text{ mm} \pm 0,2 \text{ mm}$$

with the origin given by

$$L_{23} = 13,0 \text{ mm} \pm 0,3 \text{ mm}$$

$$L_{24} = 2,0 \text{ mm} \pm 0,1 \text{ mm}$$

$$L_{25} = 114,0 \text{ mm} \pm 0,3 \text{ mm}$$

The dimensions  $L_2$ ,  $L_{23}$ , and  $L_{25}$  are interrelated; their values shall be such so that they are all three within specification.

#### 10.4.6 Gripper slots

The case shall have two symmetrical gripper slots (see Figure 6) with a depth of

$$L_{26} = 5,0 \text{ mm} \pm 0,3 \text{ mm}$$

from the edge of the case and a width of

$$L_{27} = 6,0 \text{ mm} \pm 0,3 \text{ mm}$$

The upper edge of a slot shall be

$$L_{28} = 12,0 \text{ mm} \pm 0,3 \text{ mm}$$

above the bottom of the case.

#### 10.4.7 Write-inhibit hole

The case shall have a write-inhibit hole (see Figure 7). The case shall include a device for opening and closing this hole.

When writing on the disk is not allowed, the write-inhibit hole shall be open all through the case. It shall have a diameter

$$D_3 = 4,0 \text{ mm min.}$$

Its centre shall be specified by

$$L_{29} = 8,0 \text{ mm} \pm 0,2 \text{ mm}$$

$$L_{30} = 111,0 \text{ mm} \pm 0,3 \text{ mm}$$

on Side A of the case.

When writing is allowed on the disk, the write-inhibit hole shall be closed, at a depth of typically  $L_{10}$ , i.e. the wall thickness of the case. In this state, the opposite side of the hole, at Side B of the case, shall be closed and not recessed from the external surface of this side by more than

$$L_{31} = 0,4 \text{ mm max.}$$

#### 10.4.8 Media identification sensor areas

Media identifications sensor holes are considered to be used for identification of future other holographic cartridges. The cartridge specified in this Ecma Standard is considered to correspond to a closed state of these holes.

Identification of the cartridge of this Ecma Standard shall be done by sensing that the external surface of Side A of case is not deviating from Case Reference Plane P by more than 0,3 mm within the four identification areas (see Figure 8) having a diameter

$$D_4 = 4,0 \text{ mm} \begin{matrix} + 0,3 \text{ mm} \\ - 0,0 \text{ mm} \end{matrix}$$



and centres specified by

$$L_{32} = 19,5 \text{ mm} \pm 0,2 \text{ mm and } L_{30}$$

$$L_{33} = 105,0 \text{ mm} \pm 0,3 \text{ mm}$$

$$L_{34} = 17,0 \text{ mm} \pm 0,2 \text{ mm}$$

$$L_{35} = 11,0 \text{ mm} \pm 0,2 \text{ mm.}$$

#### 10.4.9 Head and motor windows

The case shall have a window on each side to allow the spindle of the drive to clamp the disk by its centre hole and to allow the head to access the disk (see Figure 9). The dimensions are referenced to a centreline, located at a distance of

$$L_{36} = 61,0 \text{ mm} \pm 0,2 \text{ mm}$$

to the left of reference axis Y.

The width of the head access shall be defined by

$$L_{37} = 16,0 \text{ mm min.}$$

$$L_{38} = 16,0 \text{ mm min.}$$

and its height shall extend to

$$L_{39} = 113,2 \text{ mm min.}$$

The two inside corners shall be rounded with a radius of

$$R_8 = 3,0 \text{ mm max.}$$

The motor spindle access shall have a diameter of

$$D_5 = 32,0 \text{ mm min.}$$

and its centre shall be defined by  $L_{36}$  and

$$L_{40} = 43,0 \text{ mm} \pm 0,2 \text{ mm}$$

#### 10.4.10 Shutter

The case shall have one spring-loaded, unidirectional shutter (see Figure 10), designed to completely cover the head and motor windows when closed. In the closed position the shutter shall be locked and the case shall have the light-proof characteristics of 10.6.

A shutter movement of  $38,7 \text{ mm}^{+1,4 \text{ mm}}$  shall ensure that the head and motor windows are opened to the minimum size specified in 10.4.9.  $^{-0,7 \text{ mm}}$

When unlocked, the shutter shall be free to slide in a recessed area of the case in such a way as to ensure that the overall thickness of the case and shutter shall not exceed  $L_8$ .

The top surface of the shutter shall not be over the top edge of the case.

#### 10.4.11 Shutter unlocking levers

Unlocking of the shutter shall be only obtained by a combined action on two spring-loaded levers configured as shown on Figures 10 and 10a. The levers shall be designed to be operated by a mechanism of the drive. The first lever shall be displaced by a defined distance ( $L_{46}$ ) to unlock the second lever, which shall be then displaced by another defined distance ( $L_{57}$ ) to unlock the shutter, which can then be pushed open.

The locked and unlocked configurations of the levers shall be as shown on Figure 10a.

The first lever shall be located on the right hand edge of Side A of the case.

When the shutter is locked in its closed position, the distances from the extremity of the first lever to references axes X and Y shall be

$$L_{41} = 103,6 \text{ mm} \pm 0,3 \text{ mm}$$

$$L_{42} = 6,0 \text{ mm} \pm 0,2 \text{ mm.}$$

The height of the first lever shall be

$$L_{43} = 5,6 \text{ mm} \pm 0,2 \text{ mm.}$$

Its centre shall be

$$L_{44} = 5,5 \text{ mm} \pm 0,2 \text{ mm}$$

from the Case Reference Plane P of the case, and its width shall be

$$L_{45} = 4,0 \text{ mm} \pm 0,2 \text{ mm}$$

The first lever displacement to unlock the second lever shall be

$$L_{46} = 2,0 \text{ mm} \begin{matrix} +1,2 \text{ mm} \\ -0,5 \text{ mm} \end{matrix}$$

A rectangular sub-slot shall be located in the insertion slot on each side of the lever (see Figure 10a)

The sub-slot shall have a length of

$$L_{47} = 38,0 \text{ mm} \pm 0,3 \text{ mm}$$

with a width of

$$L_{48} = 2,80 \text{ mm} \pm 0,15 \text{ mm}$$

A symmetrical sub-slot shall be located in the left-hand side insertion slot.

The distance from the bottom of the right-hand side sub-slot to reference axis Y shall be

$$L_{49} = 2,8 \text{ mm} \begin{matrix} + 0 \text{ mm} \\ - 0,2 \text{ mm} \end{matrix}$$

and the distance from the bottom of the left-hand side sub-slot to the reference axis Y shall be

$$L_{50} = 124,8 \text{ mm} \begin{matrix} + 0 \text{ mm} \\ - 0,4 \text{ mm} \end{matrix}$$

The second lever shall be located on side A of the case.

This lever shall be moved by its rectangular hole.

The distances from the centre of the rectangular hole to the reference axes X and Y shall be

$$L_{51} = 117,7 \text{ mm} \pm 0,3 \text{ mm}$$

$$L_{52} = 11,3 \text{ mm} \pm 0,3 \text{ mm}$$

The length of the rectangular hole shall be

$$L_{53} = 4,2 \text{ mm} \pm 0,2 \text{ mm}$$

The width of the rectangular hole shall be

$$L_{54} = 4,1 \text{ mm} \pm 0,2 \text{ mm}$$

The distance from the top of the rectangular hole to the Case Reference Plane P shall be

$$L_{55} = 2,5 \text{ mm} \pm 0,2 \text{ mm}$$

The thickness of the second lever shall be

$$L_{56} = 6,0 \text{ mm} \pm 0,2 \text{ mm}$$

The second lever displacement to unlock the shutter shall be

$$L_{57} = 2,2 \text{ mm} \begin{matrix} +1,3 \text{ mm} \\ -0,5 \text{ mm} \end{matrix}$$

#### 10.4.12 Slider for shutter opener

The shutter shall have one slider (see Figures 10 and 10b) that can be operated by the shutter opener of the drive to open the shutter, after unlocking by the two levers. The slider shall be dimensioned as follows:

When the shutter is closed, the right-hand of projection of the slider used to push the shutter open shall be located at a distance of

$$L_{58} = 3,5 \text{ mm} \pm 0,3 \text{ mm}$$

from reference axis Y.

The width of the projection of the slider shall be

$$L_{59} = 2,0 \text{ mm} \pm 0,2 \text{ mm}$$

The height of the projection of the slider shall be

$$L_{60} = 3,2 \text{ mm} \pm 0,2 \text{ mm}$$

The centre of the projection of the slider from the Case Reference Plane P of the case shall be

$$L_{61} = 5,5 \text{ mm} \pm 0,2 \text{ mm}$$

The length of the projection of the slider shall be

$$L_{62} = 3,5 \text{ mm max.}$$

The top of the projection of the slider shall be at a distance  $L_2$  of the reference axis X.

#### 10.4.13 Feature to prevent insertion into UDO, MO and WO drives

The top edge side of the shutter shall have no slot (see Figures 2 and 10) so as to prevent from insertion into UDO, MO, WO drives using cartridges conforming to Standards ECMA-350, ECMA-322, ECMA-280, ECMA-238, ECMA-195, ECMA-184, ECMA-183 and ECMA-153.

#### 10.4.14 User label areas

The case shall have the following minimum areas for user labels (see Figures 11a and 11b):

on Sides A and B: 25 mm x 79 mm

on the bottom side: 7,0 mm x 115,0 mm

These areas shall be recessed by 0,2 mm min. Their positions are specified by the following dimensions and relations between dimensions.

$$L_{63} = 14,5 \text{ mm min.}$$

$$L_{64} - L_{63} = 79 \text{ mm min.}$$

$$L_{66} - L_{65} = 25 \text{ mm min.}$$

$$L_4 - L_{67} - L_{68} = 115,0 \text{ mm min.}$$

$$L_8 - L_{69} - L_{70} = 7,0 \text{ mm min.}$$

### 10.5 Mechanical characteristics

All requirements of this clause shall be met in the operating environment.

#### 10.5.1 Materials

The case shall be constructed from any suitable materials such that it meets the requirements of this Ecma Standard.

#### 10.5.2 Mass

The mass of the case without the holographic disk shall not exceed 200 g.

#### 10.5.3 Edge distortion

The cartridge shall meet the requirement of the edge distortion test defined in Annex A.

#### **10.5.4 Compliance**

The cartridge shall meet the requirement of the compliance (flexibility) test defined in Annex B. The requirement guarantees that a cartridge can be constrained in the proper plane of operation within the drive.

#### **10.5.5 Shutter opening force**

The spring force on the shutter shall be such that the force required to open the shutter does not exceed 2 N. It shall be sufficiently strong to close a free-sliding shutter, irrespective of the orientation of the case.

#### **10.5.6 Levers unlocking forces**

The spring forces on the levers shall be sufficiently strong to maintain the shutter locked in any orientations of the case, and such that the force exerted on each lever to unlock the shutter does not exceed 1N.

### **10.6 Light-proof characteristics**

The Holographic Disk Cartridge with closed and locked shutter shall withstand the light proof test as defined in Annex C.

### **10.7 Drop test**

The Holographic Disk Cartridge shall withstand dropping on each surface and on each corner from a height of 0,75 m onto a concrete floor covered with a vinyl layer 2 mm thick. The cartridge shall withstand all such impacts without any functional failure.

The write-inhibit switch shall not move to change the state (open or closed) of the write-inhibit hole during the drop test.

### **10.8 Electro-static discharge test**

The Holographic Disk Cartridge shall meet the electro-static discharge requirements specified in Annex D.

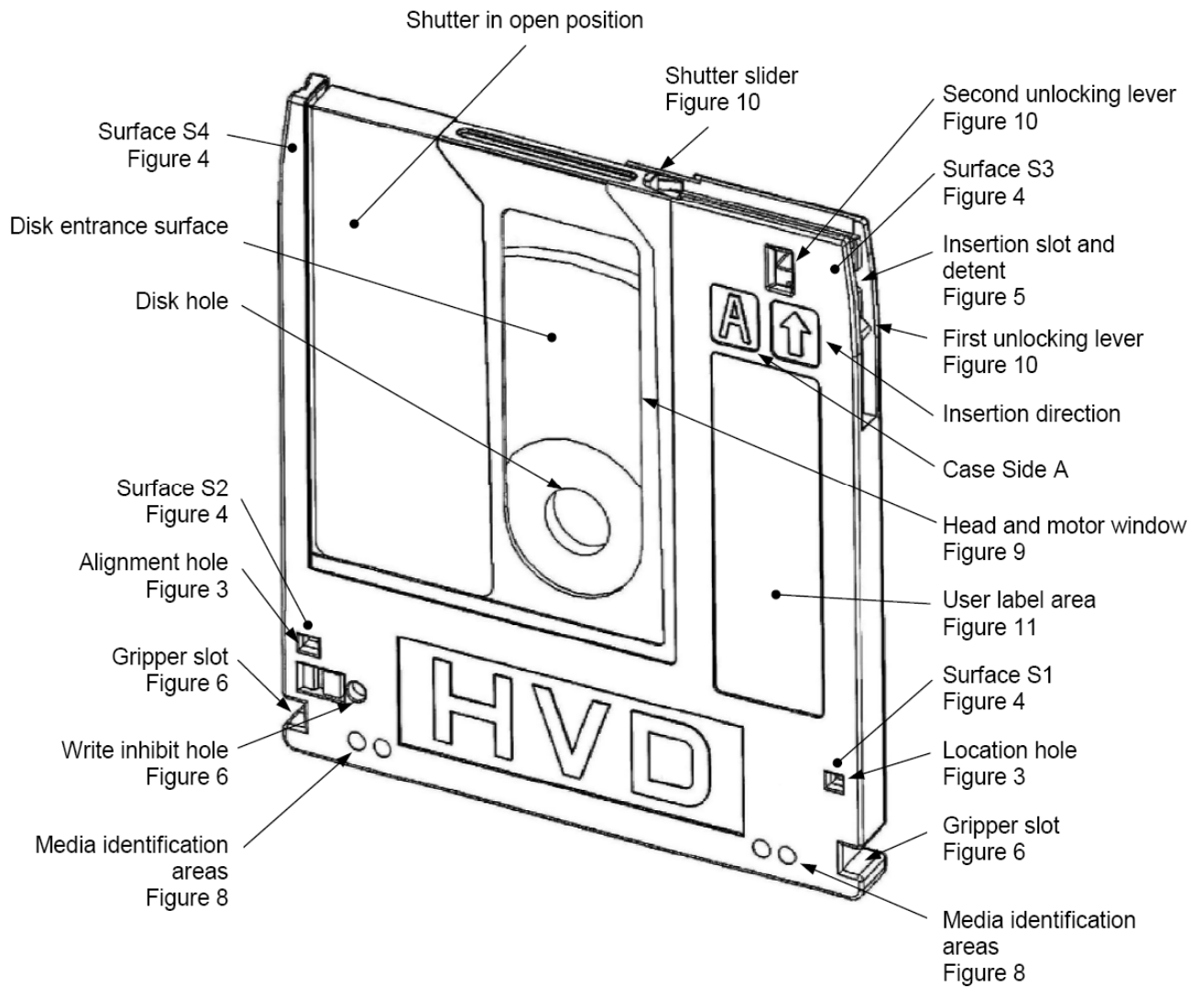

Figure 2 – Case seen from Side A

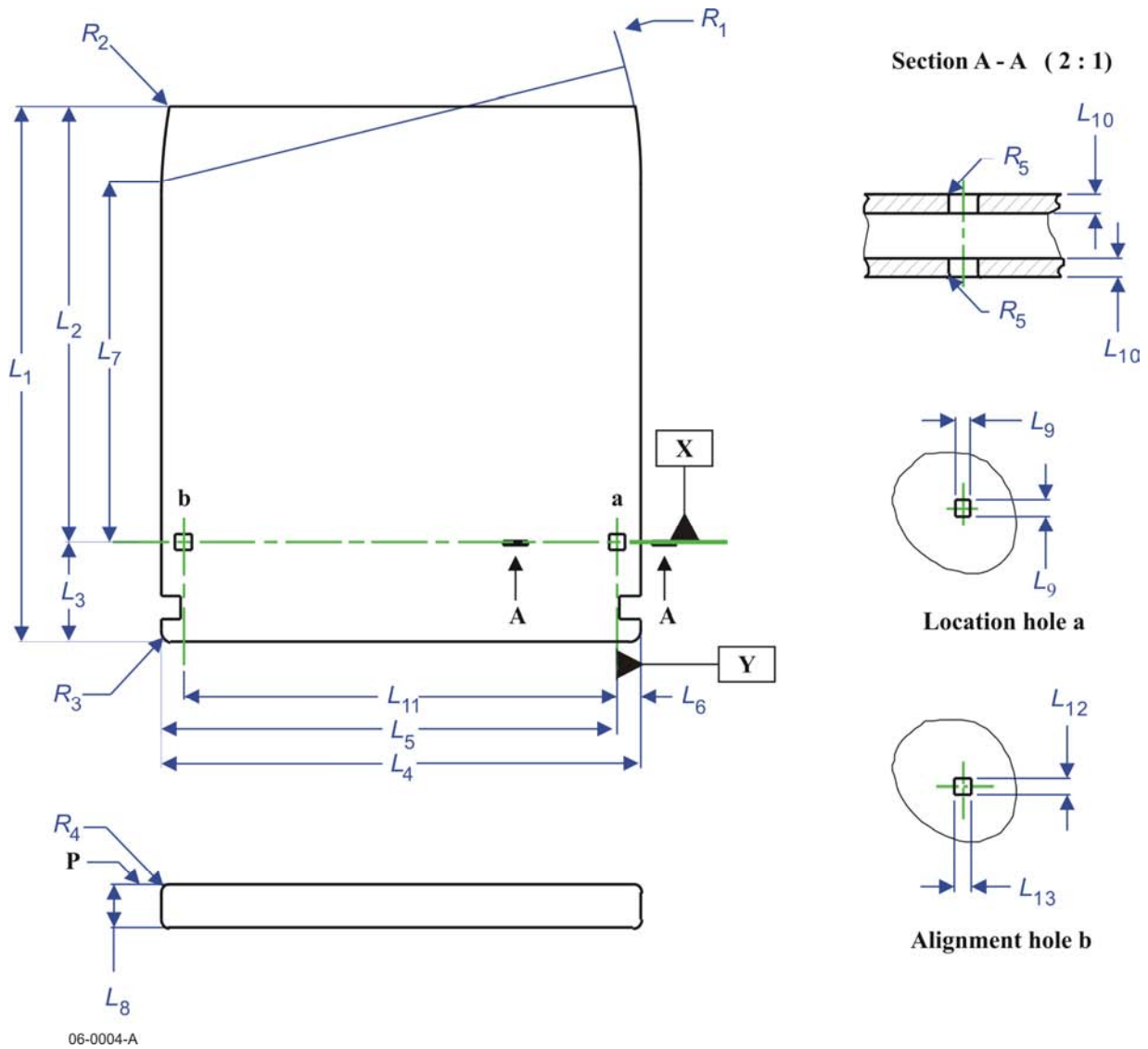
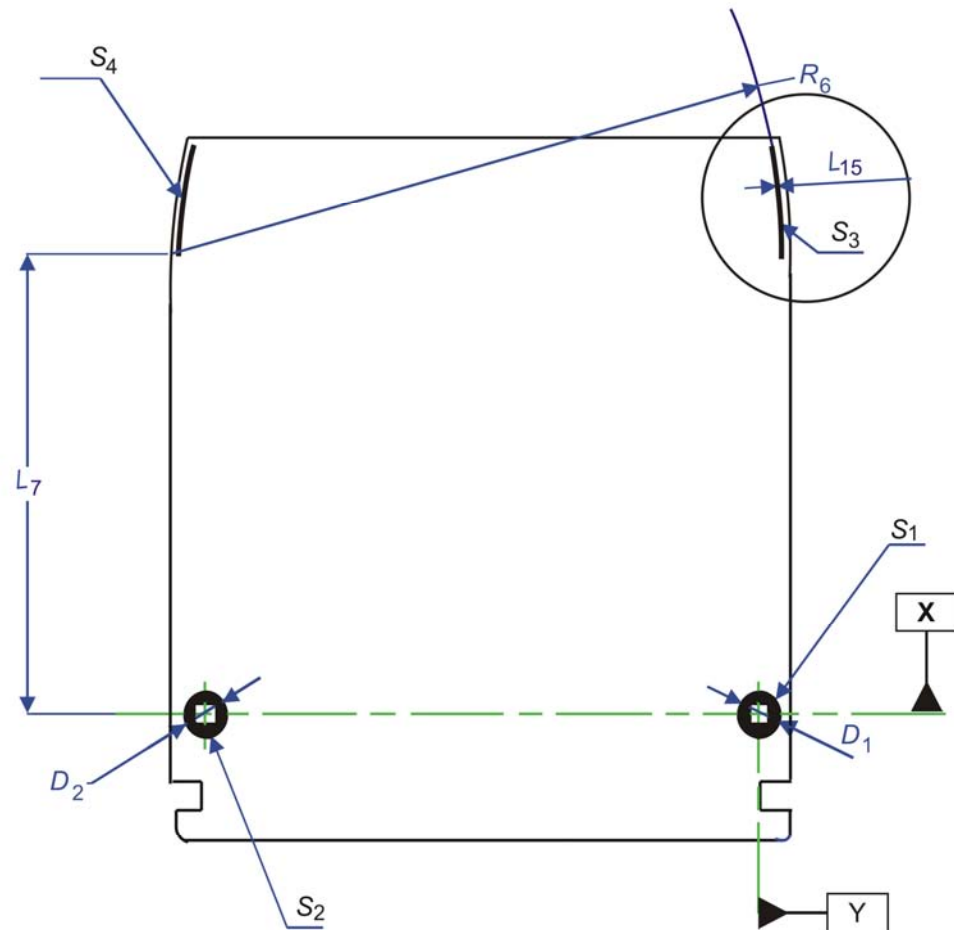
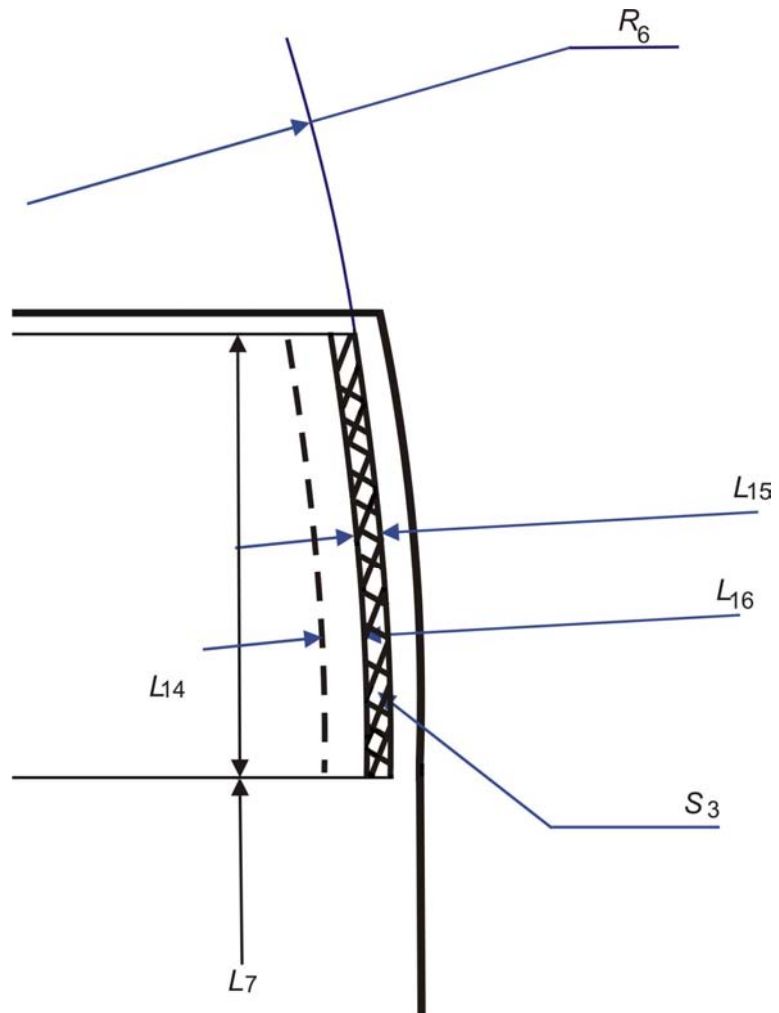

Figure 3 – Overall dimensions and reference axes seen from Side A



06-0005-C

Figure 4 – Surfaces S1, S2, S3 and S4 of the Case Reference Plane P on Side A



06-0005-D

Figure 4a – Details of surface S3



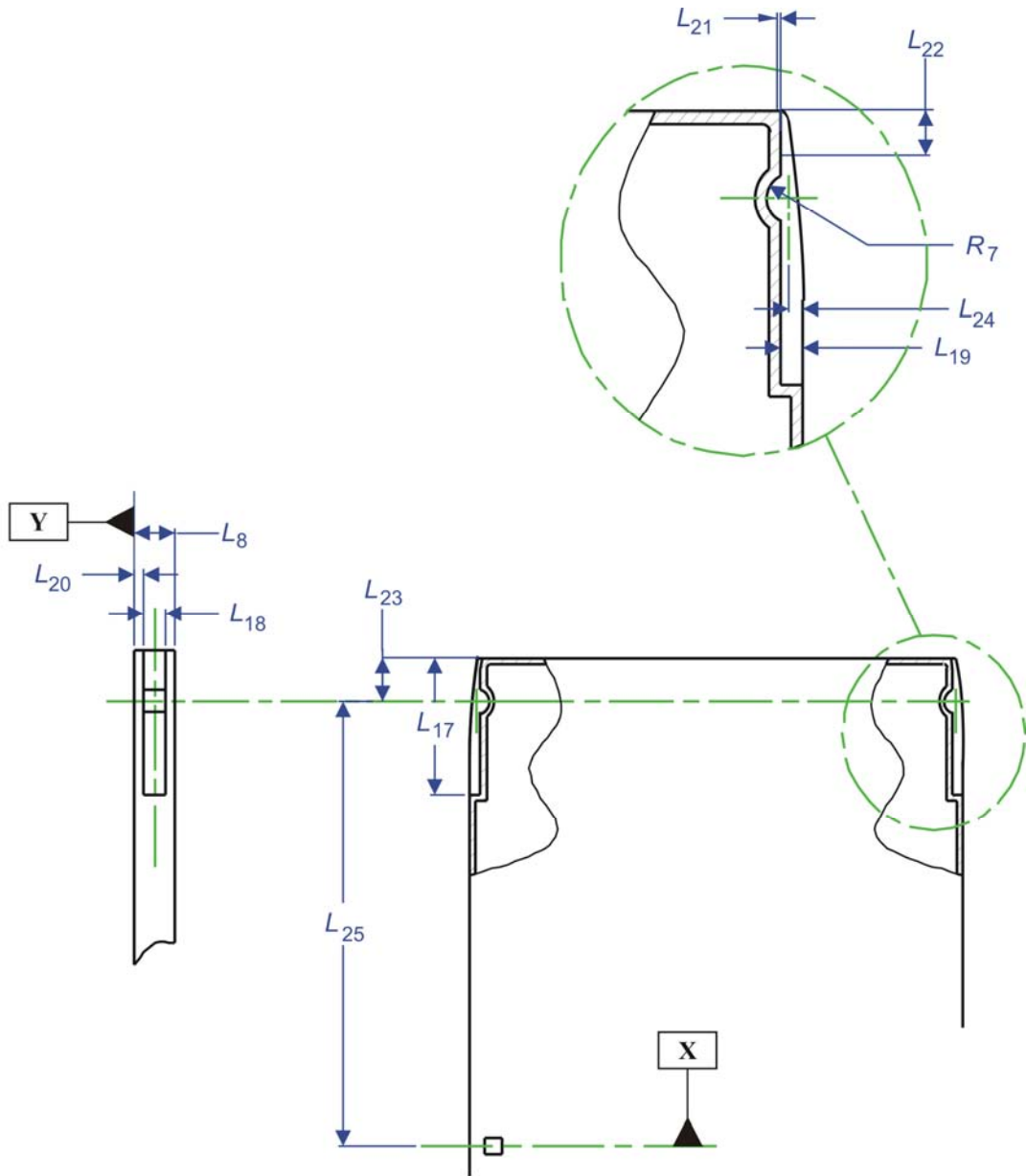

03-0004-B

Figure 5 – Insertion slots and detents

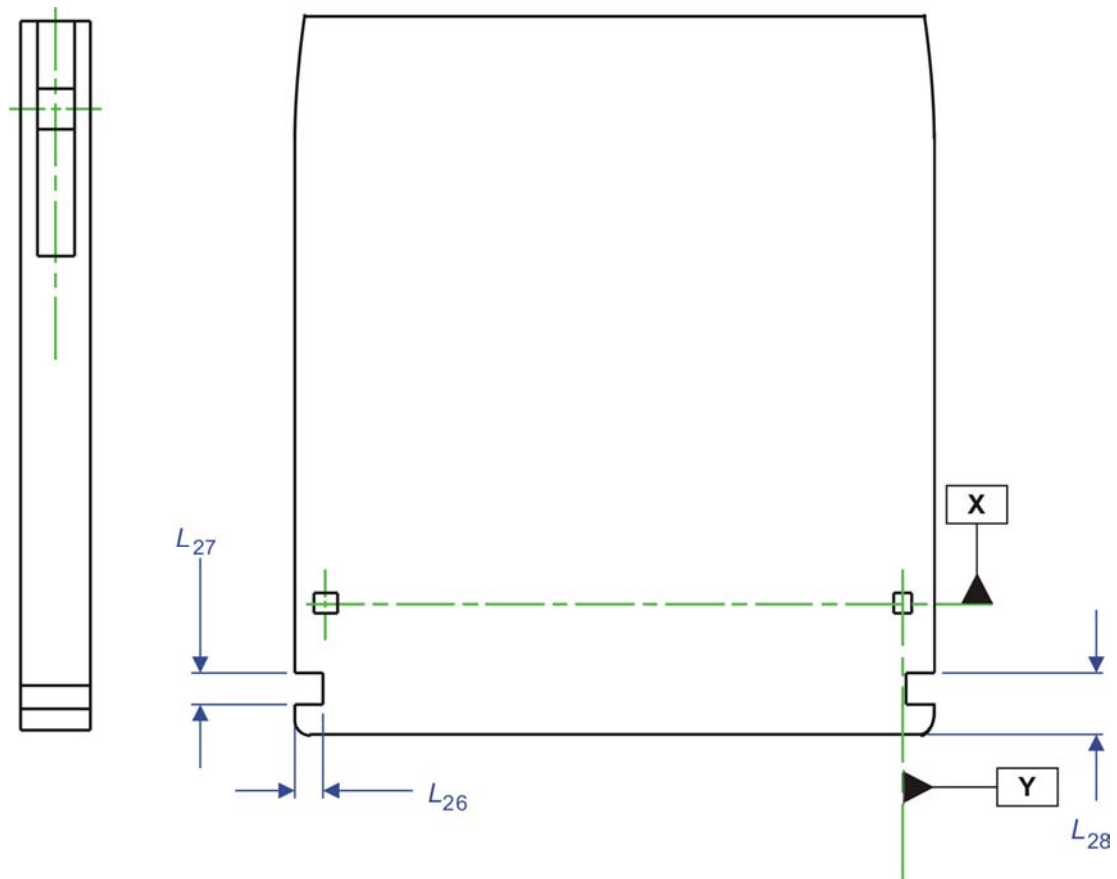

06-0007-B

Figure 6 – Gripper slots

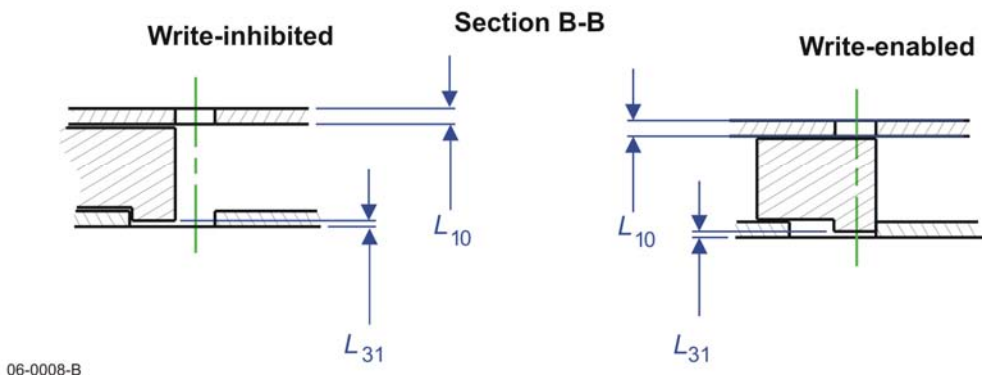
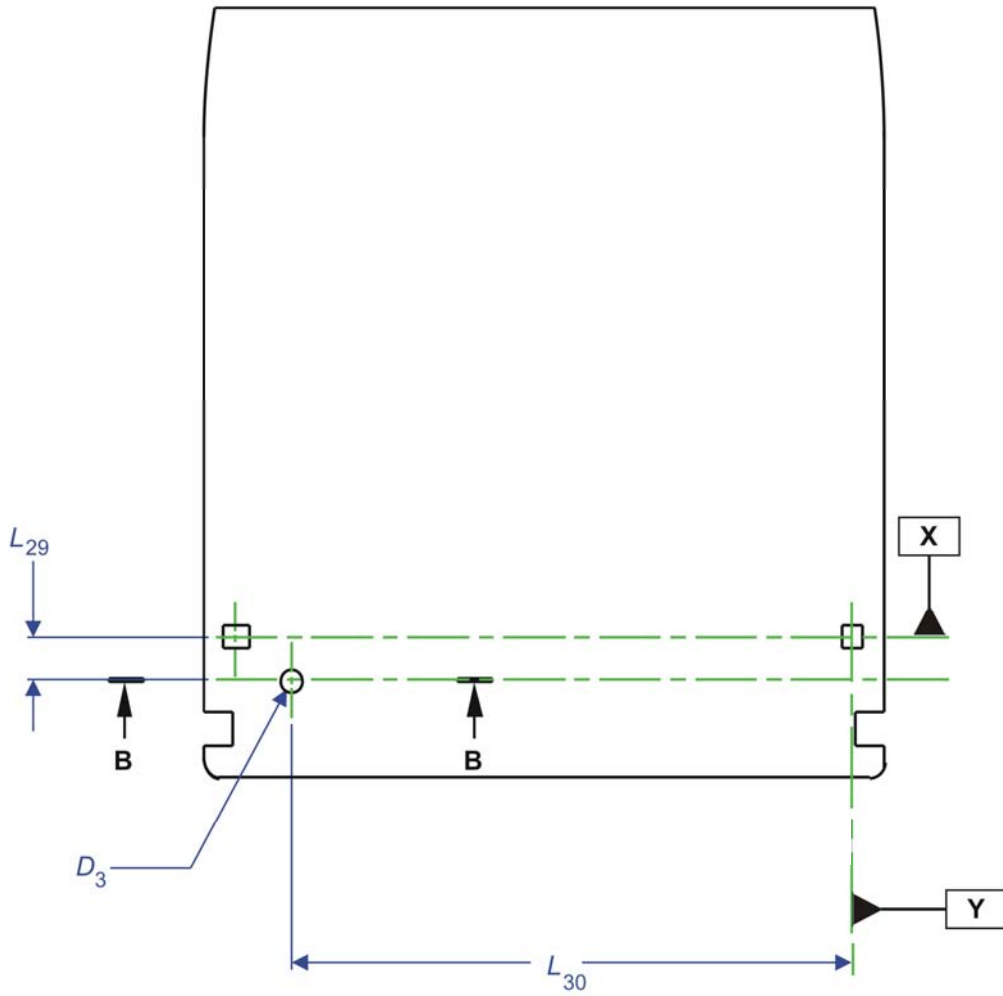

06-0008-B

Figure 7 – Write-inhibit hole seen from Side A

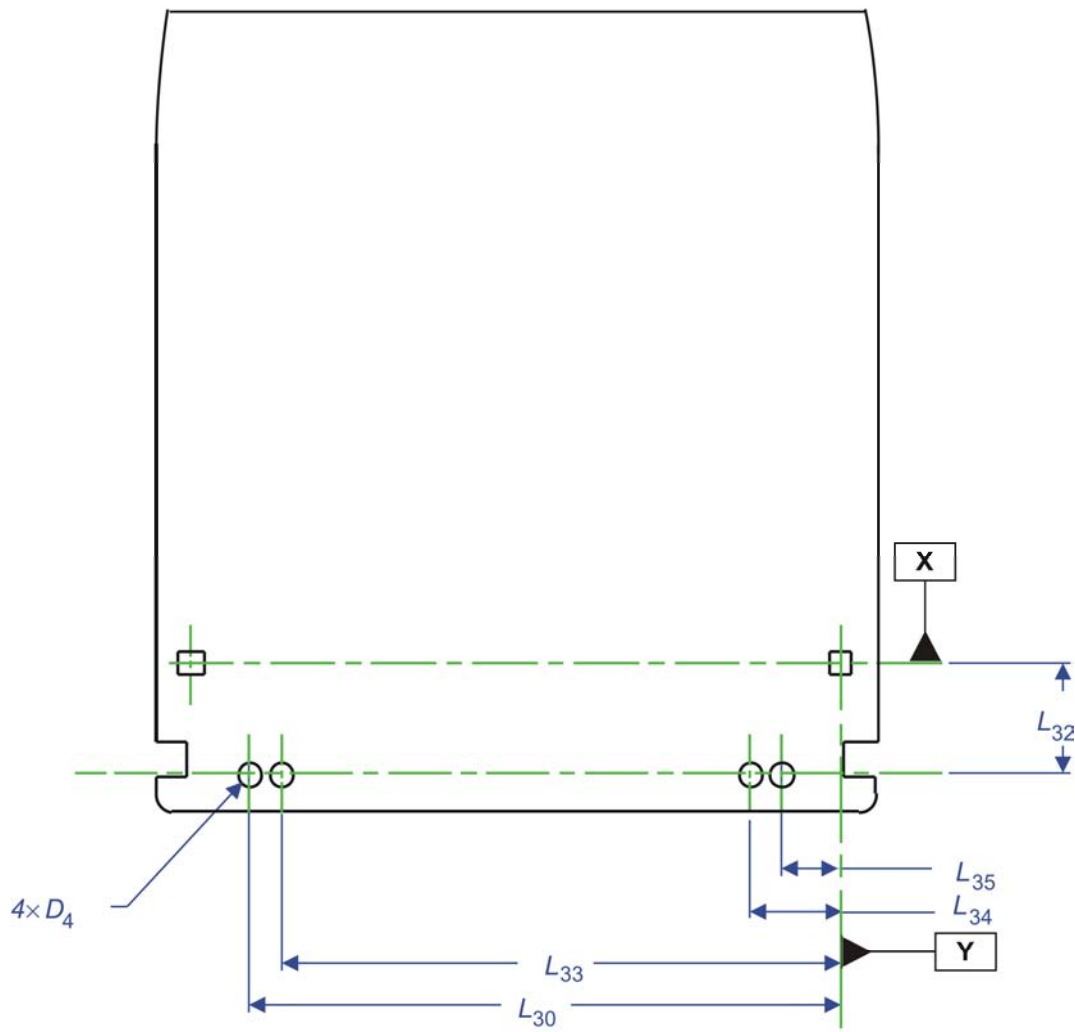

06-0009-C

Figure 8 – Media identification sensor areas on Side A

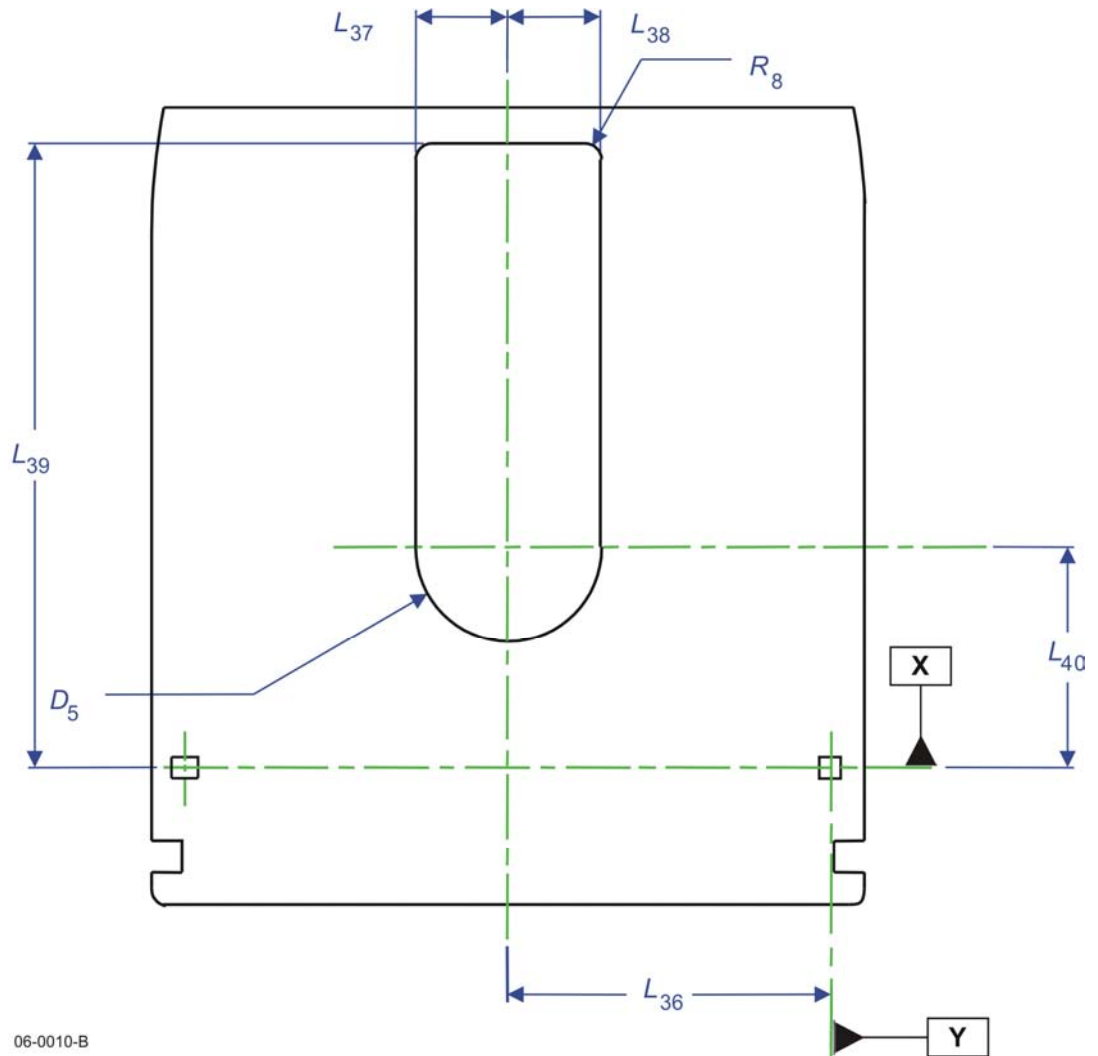

Figure 9 – Head and motor windows on Side A

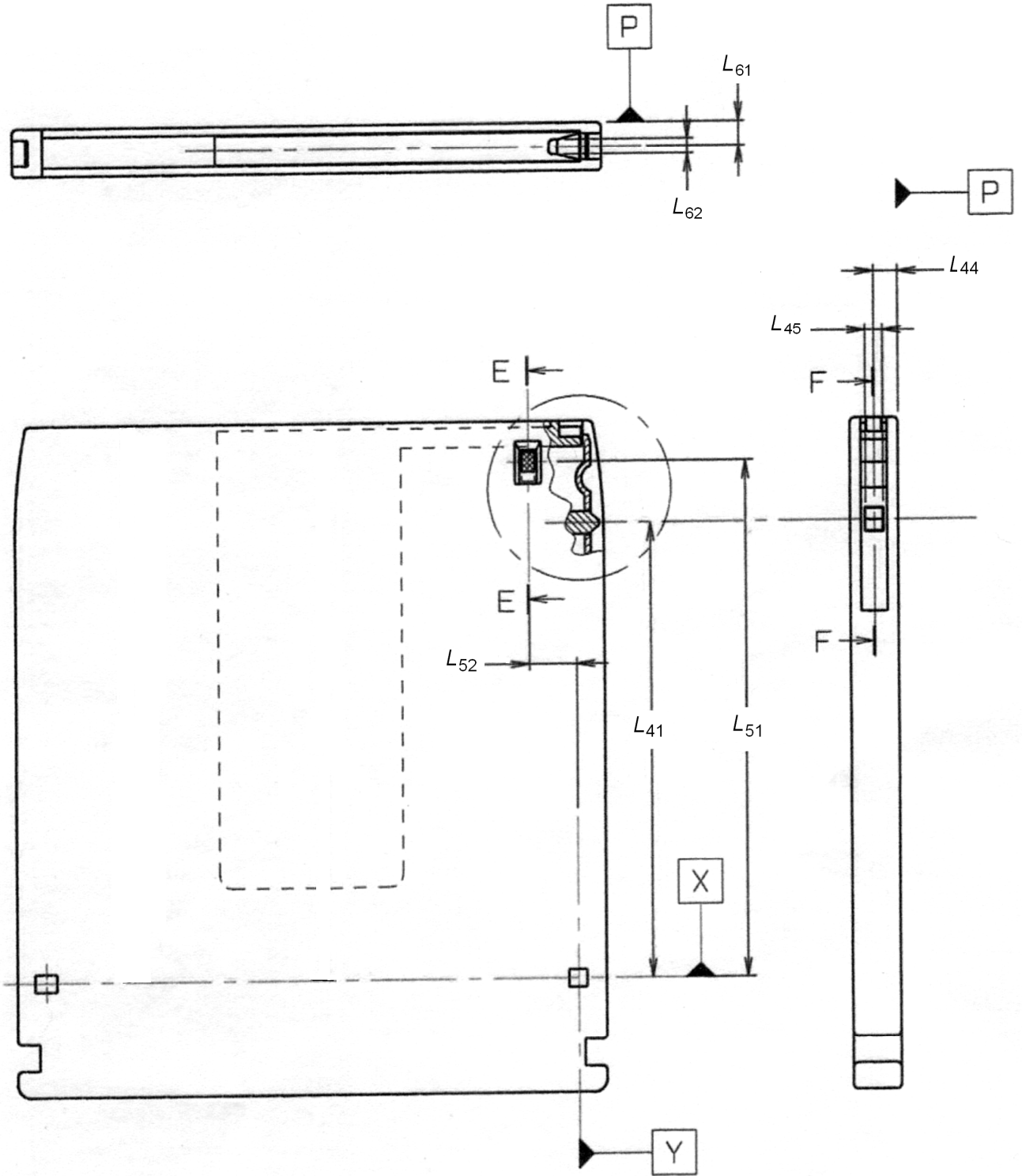

Figure 10 – Shutter opening features seen from Side A

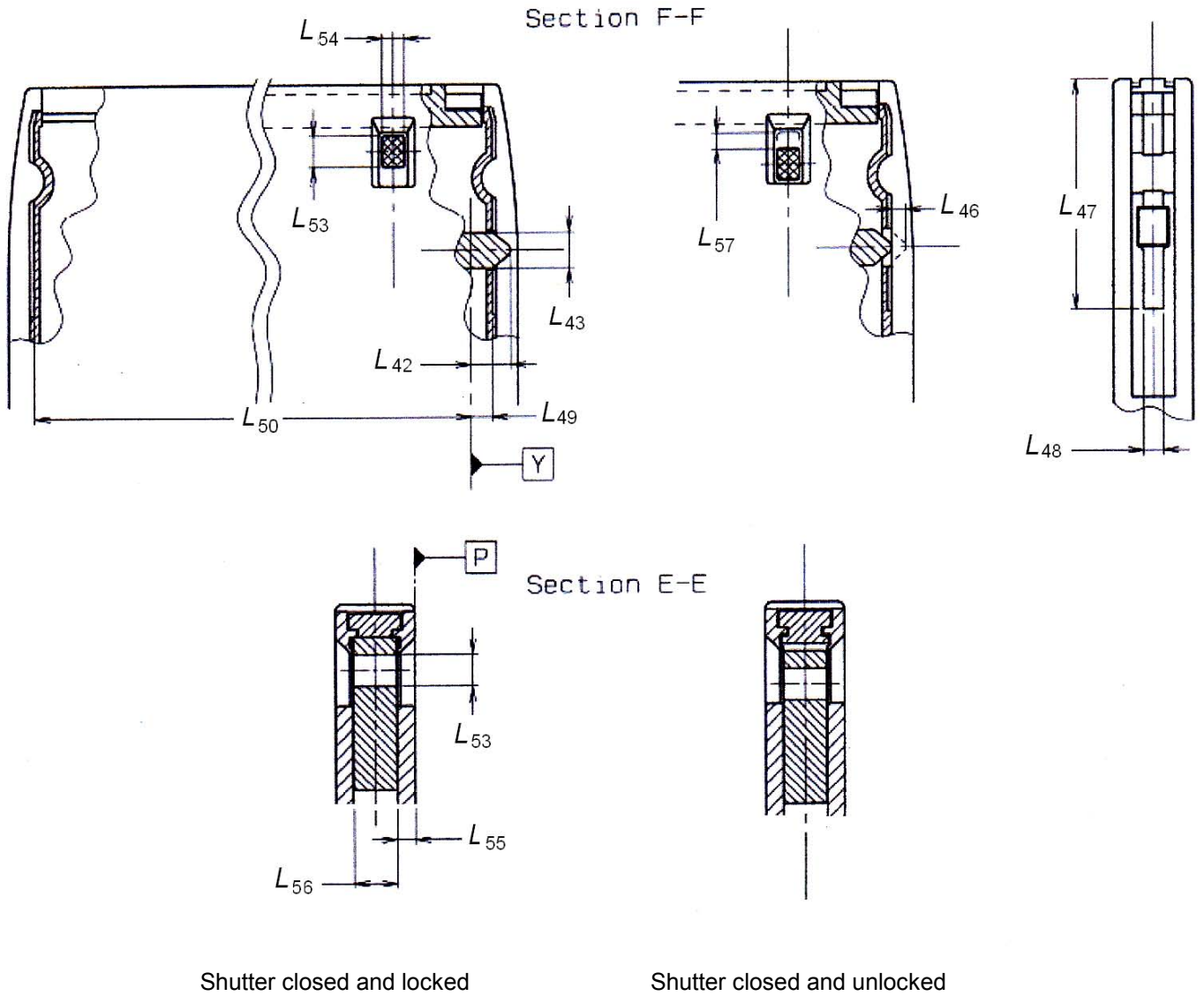

Figure 10a – Locked/unlocked shutter levers configurations

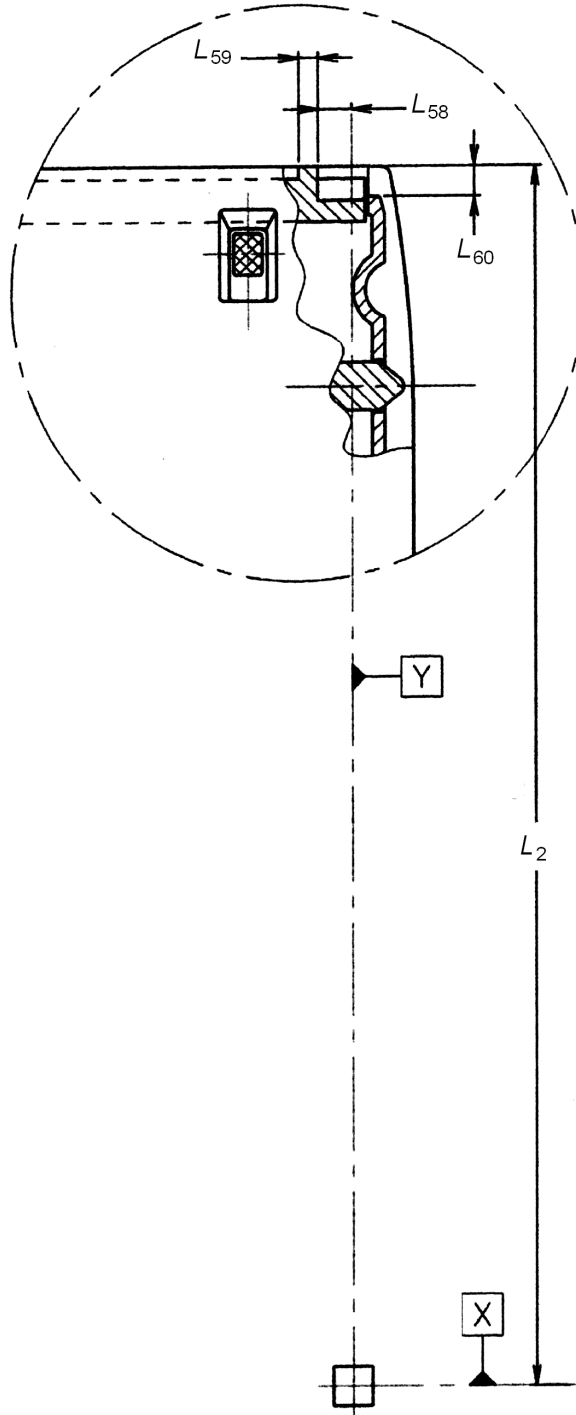

Figure 10b – Shutter slider seen from Side A



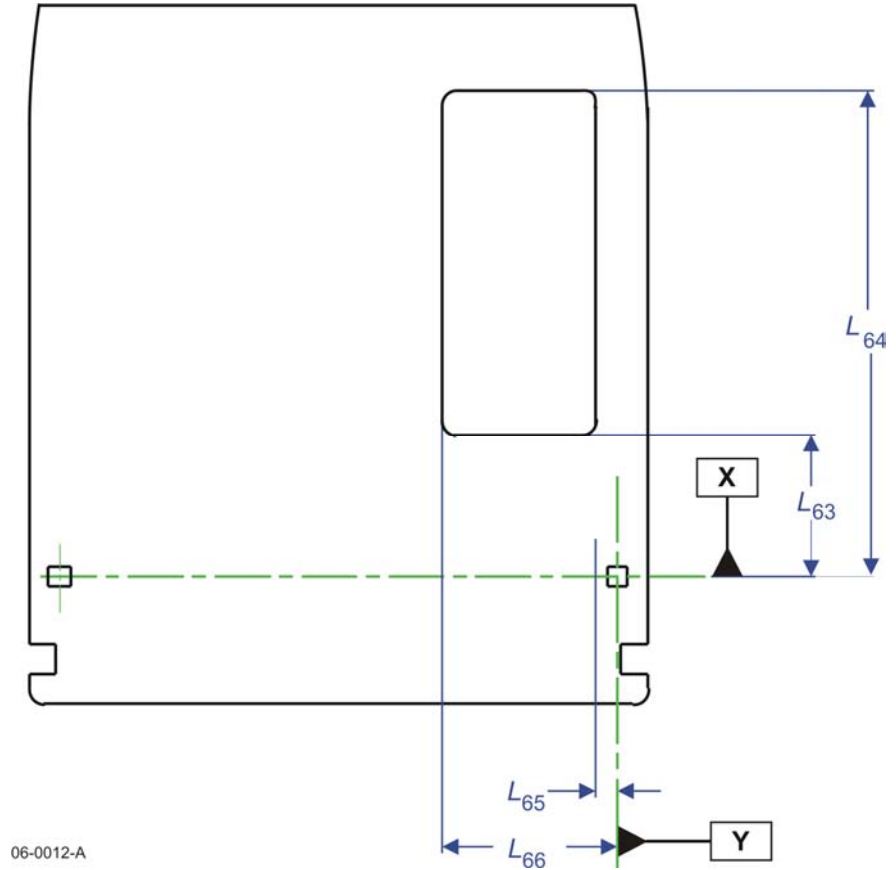

Figure 11a – User label area on Side A

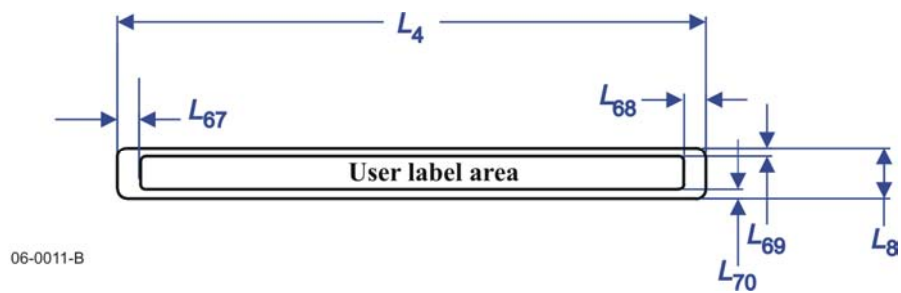

Figure 11b – User label area on bottom surface

## 11 Dimensional, mechanical, and physical characteristics of the disk

### 11.1 General description of the disk

The disk shall consist of a circular substrate with a hole in the centre, bearing a stack of layers incorporating the holographic recording layer (see Figure 12). The recording layer is protected from environmental influences by a laser-transparent protective cover layer.

The centring of the disk on the drive spindle is performed on the edge of the centre hole of the substrate. Clamping is performed in the Clamping Zone (see Figure 13).

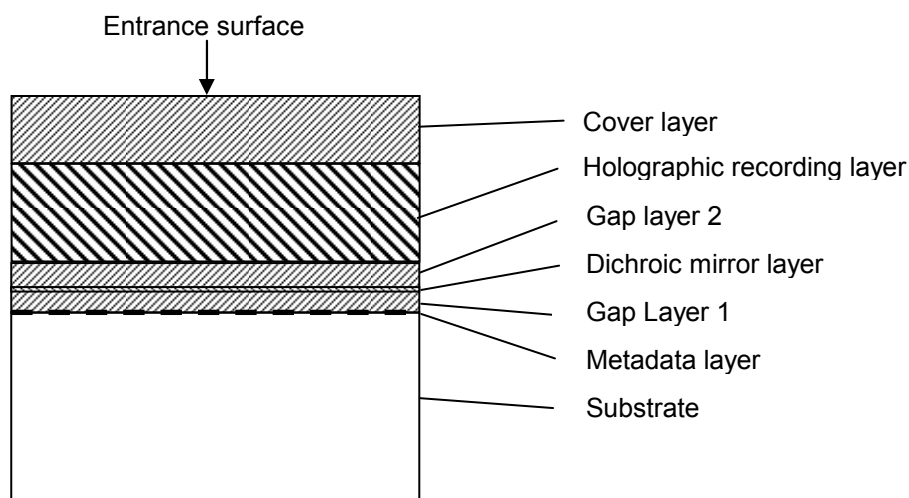

Figure 12 – Layers structure of the disk

### 11.2 Reference axis and plane of the disk

Some dimensions of the disk are referred to a Disk Reference Plane D (see Figure 13). The Disk Reference Plane D is different from the Case Reference Plane P that is described in 10.2. Plane D is defined by the perfectly flat annular surface of an ideal spindle onto which the Clamping Zone of the disk, on the entrance surface, is clamped, and which is normal to the axis of rotation of this spindle. The Reference Axis A of the disk passes through the centre of the centre hole of the disk, and is normal to Disk Reference Plane D.

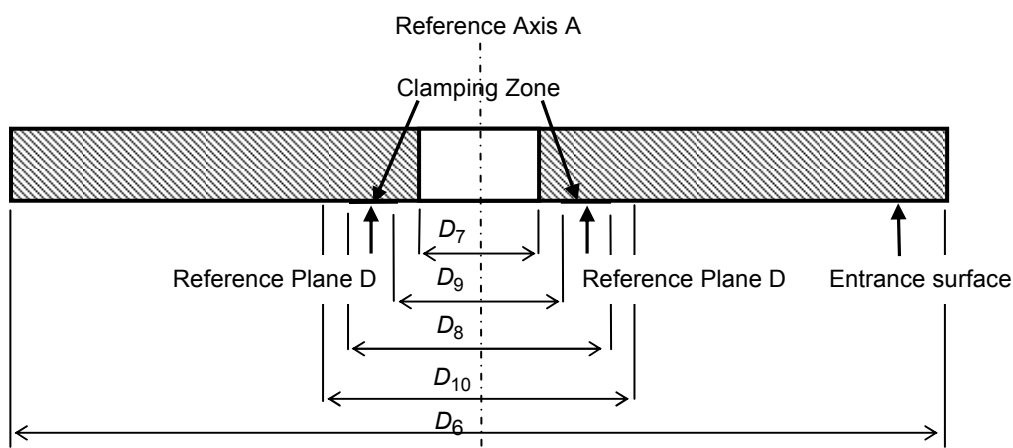

Figure 13 – Disk dimensions

### 11.3 Dimensions of the disk

The dimensions of the disk shall be measured in the operating environment. The outer diameter of the disk shall be (see Figure 13)

$$D_6 = 120 \text{ mm} \pm 0,30 \text{ mm}$$

The centre hole shall have a diameter

$$D_7 = 15,00 \text{ mm} \begin{array}{l} + 0,15 \text{ mm} \\ - 0,00 \text{ mm} \end{array}$$

There shall be no burr on the edges of the centre hole.

The edge of the centre hole shall be rounded off or chamfered. The rounding radius shall be 0,1 mm max. The chamfer shall extend over a height of 0,1 mm max.

The total thickness of the disk shall be 2,3 mm min. and 2,6 mm max.

### 11.4 Clamping Zone

The Clamping Zone is the area on the entrance surface of the disk where the clamping mechanism of the drive grips the disk and is defined by  $D_8$  and  $D_9$  (see Figure 13).

The clearance zone extending from the outer diameter of the Clamping Zone ( $D_8$ ) to the inner diameter of the reflective zone ( $D_{10}$ ) (see Clause 17) shall be excluded from the total thickness requirement; however there shall be no projection from the Disk Reference Plane D in the direction of the optical system of more than 0,2 mm in this zone.

The outer diameter of the Clamping Zone shall be

$$D_8 = 28 \text{ mm min.}$$

The inner diameter of the Clamping zone shall be

$$D_9 = 22 \text{ mm max.}$$

### 11.5 Mechanical characteristics

All requirements in this clause shall be met in the operating environment.

#### 11.5.1 Material

The disk shall be made from any suitable materials such that it meets the requirements of this Ecma Standard.

#### 11.5.2 Mass

The mass of the disk shall not exceed 80 g.

#### 11.5.3 Moment of inertia

The moment of inertia of the disk relative to axis A shall not exceed 0,160 g·m<sup>2</sup>.

#### 11.5.4 Imbalance

The imbalance of the disk relative to axis A shall not exceed 0,040 g·m.

#### 11.5.5 Axial deflection

The axial deflection of the disk is measured as the axial deviation of the tracking/addressing layer. Thus it comprises the tolerances on the thicknesses of the crossed layers, on their indexes of refraction, and the deviation of the entrance surface from the Disk Reference Plane D.

The deviation of any point of the tracking/addressing layer from its nominal position, in a direction normal to the Disk Reference Plane D, shall not exceed 0,3 mm in the Formatted Zone for rotational frequencies of the disk as specified in 9.5. The deviation shall be measured by the optical system defined in 9.1.

### 11.5.6 Axial acceleration

The maximum allowed axial error  $e_{\max}$  (see Annex P) shall not exceed 0,23  $\mu\text{m}$ , measured using the Reference Servo for axial tracking of the tracking/addressing layer. The rotational frequency of the disk shall be as specified in 9.5. The stationary part of the motor is assumed to be motionless (no external disturbances). The measurement shall be made using a servo with the transfer function

$$H_s(i\omega) = \frac{1}{3} \times \left( \frac{\omega_0}{i\omega} \right)^2 \times \frac{1 + \frac{3i\omega}{\omega_0}}{1 + \frac{i\omega}{3\omega_0}}$$

where  $\omega = 2\pi f$ ,  $\omega_0/2\pi = 450 \text{ Hz}$ ,  $i = \sqrt{-1}$

or any other servo with  $|1 + H|$  within the 20 % of  $|1 + H_s|$  in the bandwidth of 5 Hz to 1 kHz. Thus, the disk shall not require an acceleration of more than 0,38  $\text{m/s}^2$  at low frequencies from the servo motor of the Reference Servo.

### 11.5.7 Radial runout

The radial runout of the tracks in the tracking/addressing layer is measured as seen by the optical head of the Reference Drive. Thus it includes the distance between the axis of rotation of the spindle and reference axis A, the tolerances on the dimensions between axis A and the location of the track, and effects of non-uniformities in the index of refraction of the stack of layers.

The radial runout is the difference between the maximum and the minimum distance of any track from the axis of rotation, measured along a fixed radial line over one track. The radial runout shall not exceed 70  $\mu\text{m}$  as measured by the optical system under conditions of a disk mounted on a perfect sized test fixture shaft, for rotational frequencies of the disk as specified in 9.5.

### 11.5.8 Radial acceleration

The maximum allowed radial error  $e_{\max}$  (see Annex P) shall not exceed 0,022  $\mu\text{m}$ , measured using the Reference Servo for radial tracking of the tracks. The rotational frequency of the disk shall be as specified in 9.5. The stationary part of the motor is assumed to be motionless (no external disturbances).

The measurement shall be made using a servo with the transfer function

$$H_s(i\omega) = \frac{1}{3} \times \left( \frac{\omega_0}{i\omega} \right)^2 \times \frac{1 + \frac{3i\omega}{\omega_0}}{1 + \frac{i\omega}{3\omega_0}}$$

where  $\omega = 2\pi f$ ,  $\omega_0/2\pi = 650 \text{ Hz}$ ,  $i = \sqrt{-1}$

or any other servo with  $|1 + H|$  within the 20 % of  $|1 + H_s|$  in the bandwidth of 5 Hz to 1,0 kHz. Thus, the disk shall not require an acceleration of more than 0,08  $\text{m/s}^2$  at low frequencies from the servo motor of the Reference Servo.

### 11.5.9 Tilt

The tilt angle, defined as the angle that the normal to the entrance surface, averaged over a circular area of 1 mm diameter, makes with the normal to the Disk Reference Plane D, shall not exceed 0,80° in the radial direction and 0,30° in the tangential direction, in the Formatted Zone.

## 11.6 Optical characteristics

### 11.6.1 Substrate

The substrate has no optical requirement.

### 11.6.2 Metadata layer

The Metadata layer shall be constituted of a reflective layer bearing data pits.

### 11.6.3 Gap layer 1

The thickness and index of refraction of Gap layer 1 at wavelength  $\lambda_T$  shall be such that within the Formatted Zone, the combined stack of layers specifications of 11.6.8 and 11.6.9 shall be met.

### 11.6.4 Dichroic mirror layer

The reflectance of the dichroic mirror layer within the Formatted Zone, measured according to Annex E, shall be at least 80% at wavelength  $\lambda_R$  specified in 9.3 and 9.4.

### 11.6.5 Gap layer 2

The thickness, index of refraction and birefringence of Gap layer 2 at wavelength  $\lambda_T$  and  $\lambda_R$  shall be such that within the Formatted Zone, the combined stack of layers specifications of 11.6.8 and 11.6.9 shall be met.

### 11.6.6 Holographic recording layer

The holographic recording layer shall be used to record the Data Page holograms.

The recording layer characteristics are specified in Section 5.

Its thickness, index of refraction and birefringence shall be such that within the Formatted Zone, the combined stack of layers specifications of 11.6.8 and 11.6.9 shall be met.

### 11.6.7 Cover layer

The cover layer shall be used to protect the other layers.

Its thickness and index of refraction shall be such that within the Formatted Zone, the combined stack of layers specifications of 11.6.8 and 11.6.9 shall be met.

### 11.6.8 Thicknesses of the stack of layers

The thickness within the Formatted Zone of the stack "cover layer + holographic recording layer + Gap layer 2 + Dichroic mirror layer + Gap layer 1" shall be determined versus the average index of refraction  $N_{AV}$  at wavelength  $\lambda_T$ , as specified in Figure 14.

The thickness within the Formatted Zone of the stack "cover layer + holographic recording layer + Gap layer 2" shall be determined versus the average index of refraction  $N_{AV}$  at wavelength  $\lambda_R$ , as specified in Figure 15.

The average index  $N_{AV}$  of the stack of layers with individual thicknesses and indexes  $T_i$  and  $N_i$  shall be calculated as  $N_{AV} = \sum N_i \cdot T_i / \sum T_i$ , with  $1,45 \leq N_i \leq 1,65$

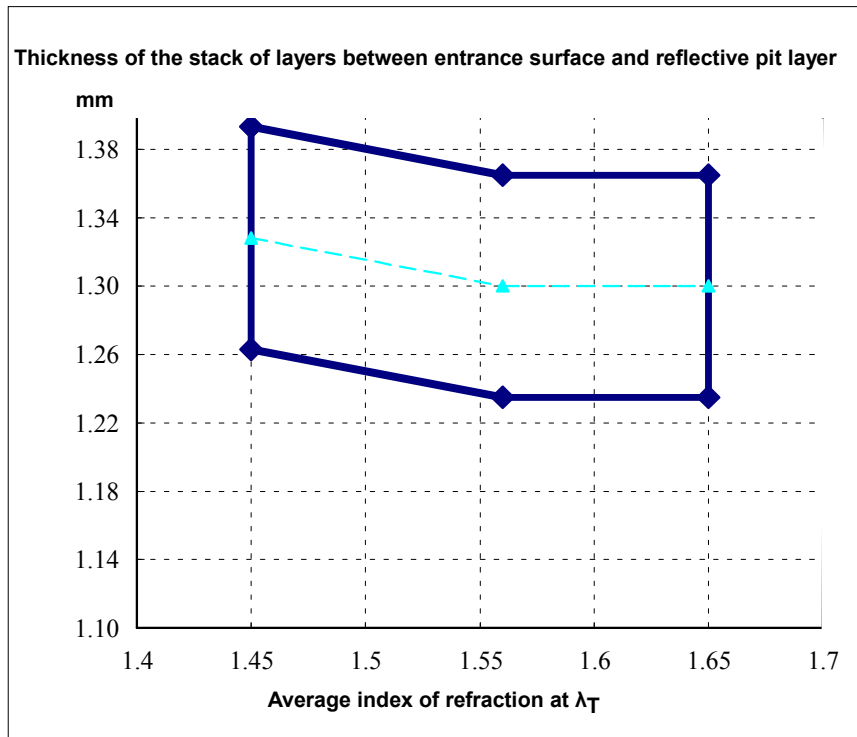

Figure 14 – Thickness of stack of layer between entrance surface and reflective pit Layer

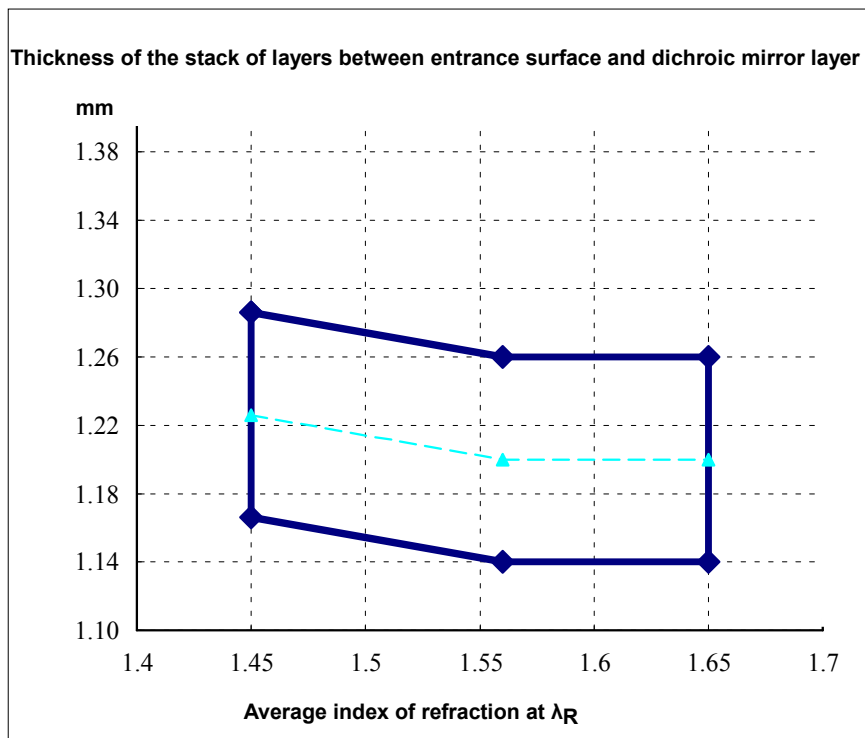

Figure 15 – Thickness of stack of layers between entrance surface and dichroic mirror layer

### 11.6.9 Birefringence of the stack of layers

The birefringence of the layers within the Formatted Zone, measured according to Annex F, shall be less than:

- 100 nm for the stack "cover layer + holographic recording layer + Gap layer 2 + Dichroic mirror layer + Gap layer 1" at wavelength  $\lambda_T$ ,
- 100 nm for the stack "cover layer + holographic recording layer + Gap layer 2" at wavelength  $\lambda_R$ .

## 12 Interface between cartridge and drive

---

### 12.1 Clamping method

When the cartridge is inserted into the drive, the shutter of the case is opened and the drive spindle engages the disk. The disk is held against the spindle by an axial clamping force. The radial positioning of the disk is provided by the centring of the axis of the spindle in the centre hole of the disk. A turntable of the spindle shall support the disk in its Clamping Zone, determining the axial position of the disk in the case.

### 12.2 Tapered cone for disk clamping

The device used for centring the disk for test measurements shall be a cone as defined in Annex G.

### 12.3 Clamping force

The clamping force exerted by the spindle shall be less than  $2,0 \text{ N} \pm 0,2 \text{ N}$ .

### 12.4 Capture cylinder

The capture cylinder (see Figure 16) is defined as the volume in which the spindle can expect the centre of the external side of the hole of the disk to be, just prior to capture. The size of the cylinder limits the allowable play of the disk inside its cavity in the case. This cylinder is referred to perfectly located and perfectly sized alignment and location pins in the drive, and includes tolerances of dimensions of the case and the disk between the pins mentioned and the said centre of the hole of the disk. The bottom of the cylinder is parallel to the Case Reference Plane P, and shall be located at a distance of

$$L_{71} = 2,45 \text{ mm min.}$$

above the Case Reference Plane P of the case. The top of the cylinder shall be located at a distance of

$$L_{72} = 6,45 \text{ mm max.}$$

above the Case Reference Plane P. The diameter of the cylinder shall be

$$D_{11} = 2,8 \text{ mm max.}$$

Its centre shall be defined by the nominal values of  $L_{36}$  and  $L_{40}$  (see 9.4.9).

### 12.5 Disk position in operating condition

When the disk is in the operating condition within the drive (see Figure 16), the disk shall not contact the case when the axis of rotation is within a circle of diameter

$$D_{12} = 0,2 \text{ mm max.}$$

and a centre given by the nominal values of  $L_{36}$  and  $L_{40}$  (see 9.4.9),

and the position of the pit layer shall be

$$L_{73} = 4,8 \text{ mm} \pm 0,15 \text{ mm}$$

above the Case Reference Plane P of the case.

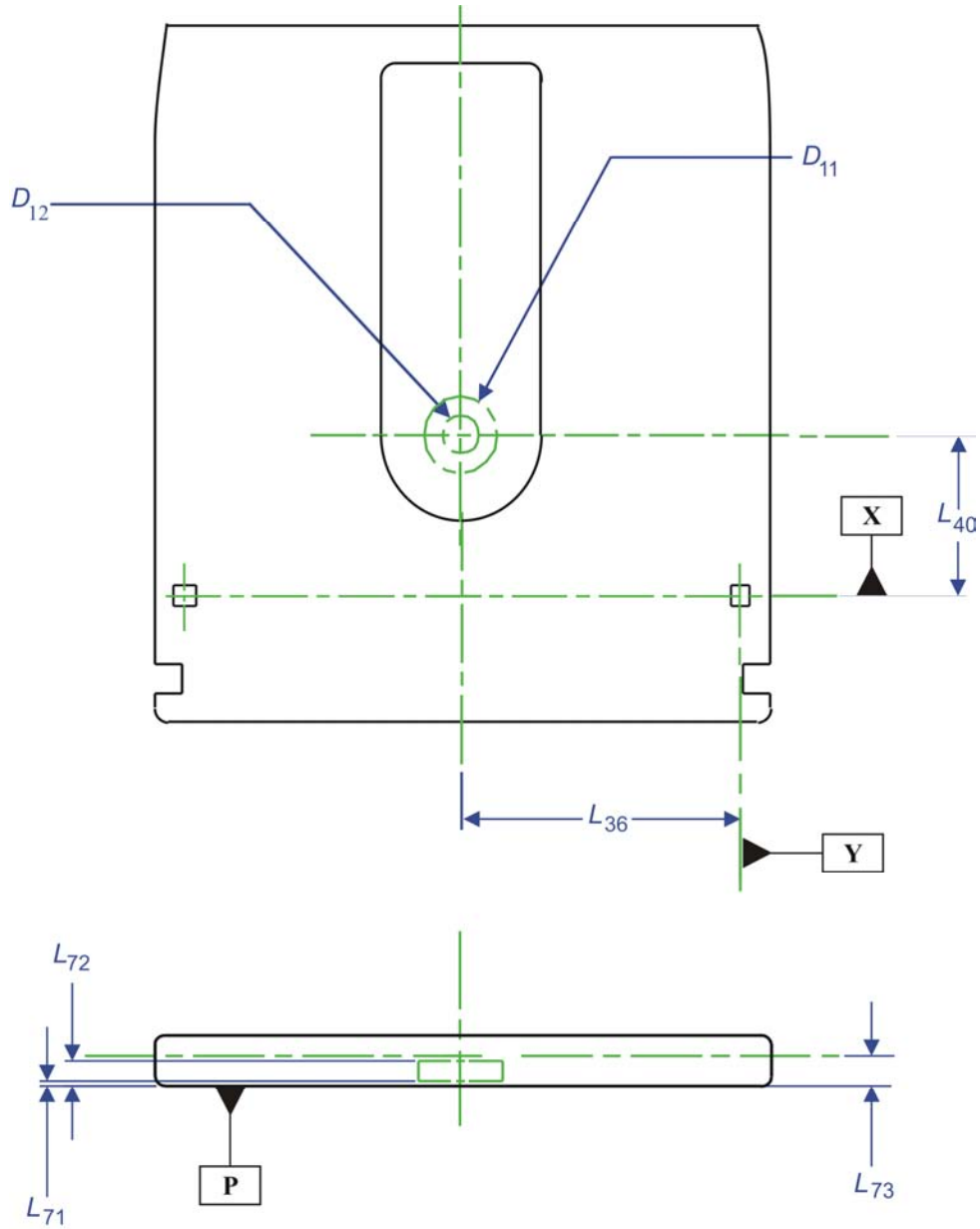

03-0013-B

Figure 16 – Capture cylinder



## Section 3 - Format of information

### 13 General description

This section specifies:

- the format of the tracking/addressing information and manufacture specific disk information contained in the pit layer,
- the format of the data information stored in form of holograms in the recording layer.

### 14 Tracking and addressing information format / Specific Disk Information format

The tracking/addressing information and manufacture Specific Disk Information shall be disposed along circular concentric tracks on the internal surface of the substrate and shall consist of successive depressions as seen from the entrance surface of the disk, called pits, in the otherwise flat reflective layer. The information shall be represented by variations of pit length and distance between pits.

There shall be 20 172 pit tracks.

The first pit track at the inside of the disk shall be located at radius 22,4 mm  $\pm 0,2$  mm  
- 0,0 mm

#### 14.1 Pit track pitch

The pit track pitch shall be  $1,6 \mu\text{m} \pm 0,1 \mu\text{m}$ .

The pit track pitch averaged over the Formatted Zone shall be  $1,6 \mu\text{m} \pm 0,01 \mu\text{m}$ .

#### 14.2 Pit track format

The pit track format is described hereafter in term of Channel bits.

Each track shall contain 302 400 Channel bits. At the nominal test rotation speed of 300 rpm the nominal channel bit time period T shall be 661 ns.

The physical Channel bit length shall consequently vary with the track radius.

##### 14.2.1 Sector

The track (one revolution) shall be divided in 120 Sectors numbered from 0 to 119.

The Sector layout shall be as shown in Figure 17.

Header	Sync	Tracking data	Land
Number of Channel bits per field			
184	40	2 288	8
Sector total Channel bits = 2 520			

Figure 17 – Sector format

### 14.2.2 Header

The header layout shall be as shown in Figure 18.

Address Mark	Address data	ECC	Reserved field
Number of Channel bits per field			
48	64	32	40
Header total Channel bits = 184			

Figure 18 – Header format

#### 14.2.2.1 Address Mark

The Address Mark shall consist of a pattern that does not occur elsewhere in the Sector. It shall have length of 48 Channel bits with the following pattern:

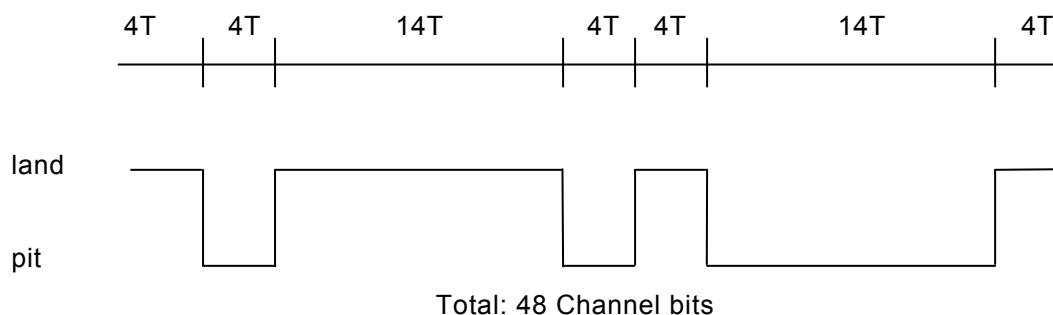

Figure 19 – Address Mark

#### 14.2.2.2 Address data

The Address data format shall be as shown in Figure 20.

Control data	Track number H	Track number L	Sector number
Number of Channel bits per field			
16	16	16	16
Address total Channel bits = 64			

Figure 20 – Address data

The Control data bits shall be generated as shown in Figure 20.a.

The track address of the first track at inner radius shall be –1 280.

The track addresses of tracks located at radii larger than Track –1 280 shall be increased by 1 for each track.

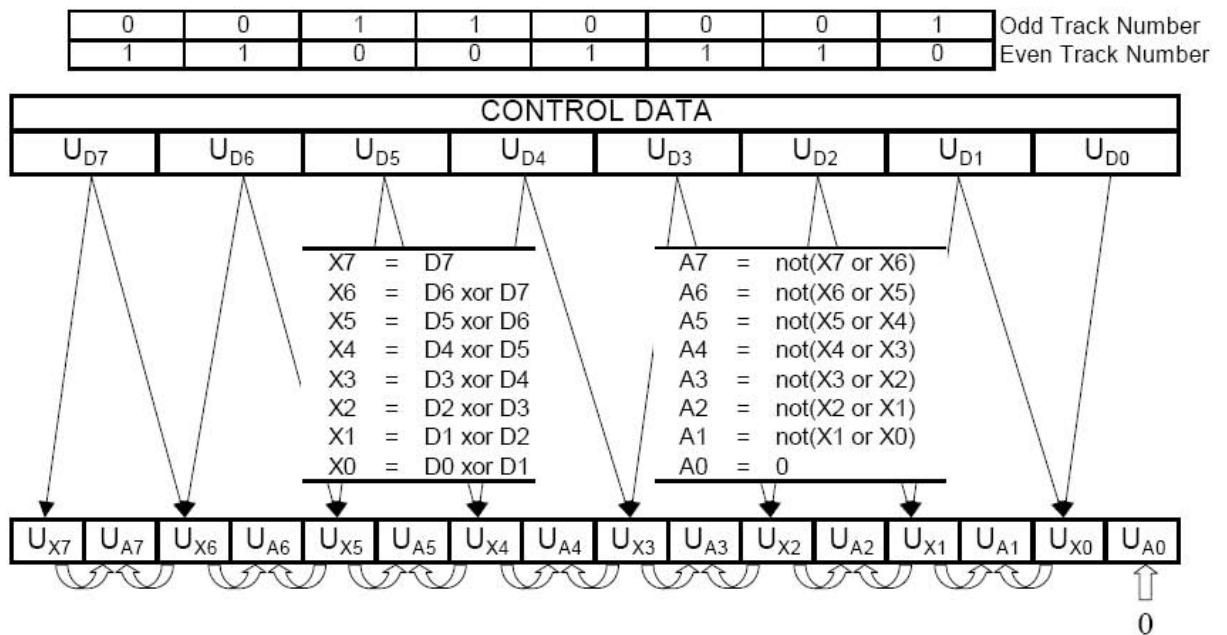

Figure 20.a – Generation of Control data

The higher 16 bits, Track Number H, of Track Number data bits shall be generated as shown in Figure 20.b.

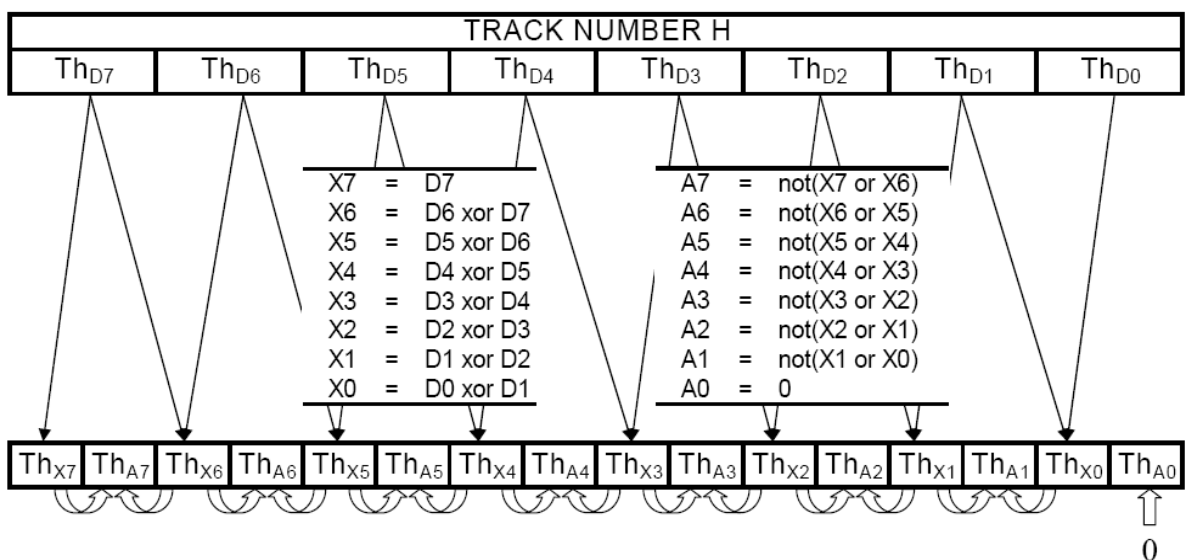

Figure 20.b – Generation of higher digits of Track Number data

The lower 16 bits, Track Number L, of Track Number data bits shall be generated as shown in Figure 20.c.

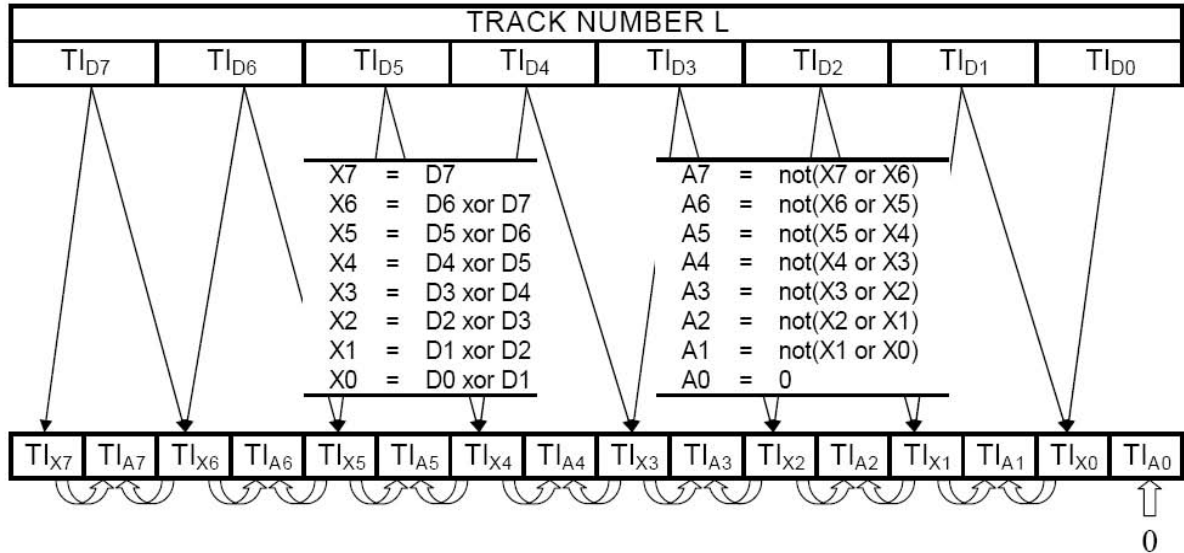

Figure 20.c – Generation of lower digits of Track Number data

The Sector Number data bits shall be generated as shown in Figure 20.d.

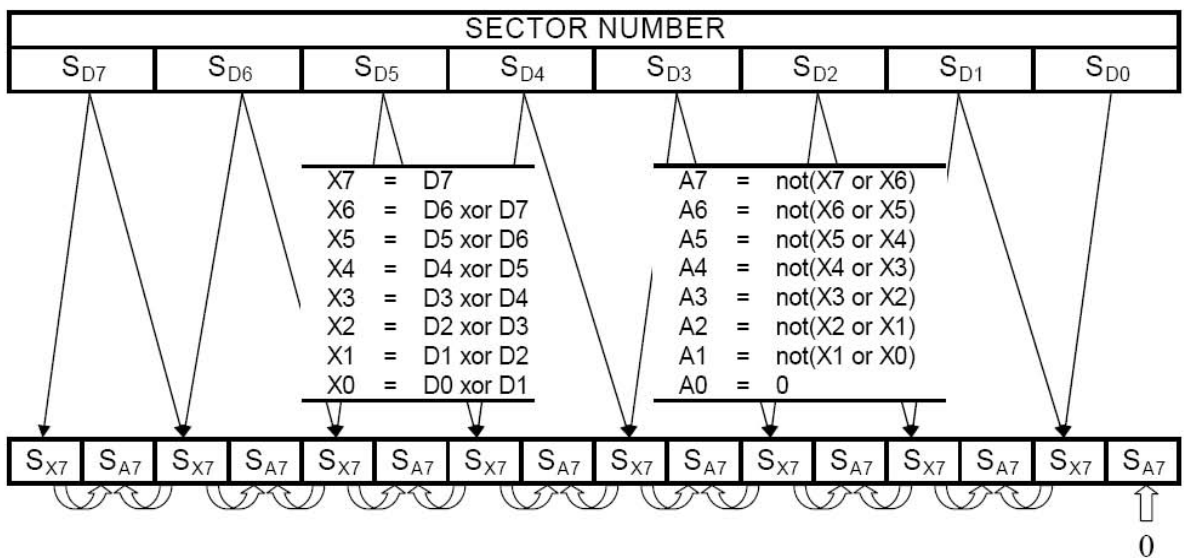

Figure 20.d – Generation of Sector Number data

### 14.2.2.3 ECC

The ECC data format shall be as shown in Figure 21.

Control data ECC	Track number H ECC	Track number L ECC	Sector number ECC
Number of Channel bits per field			
8	8	8	8
ECC total Channel bits = 32			

Figure 21 – ECC data

The higher digits of ECC data bits shall be generated as shown in Figure 21.a.

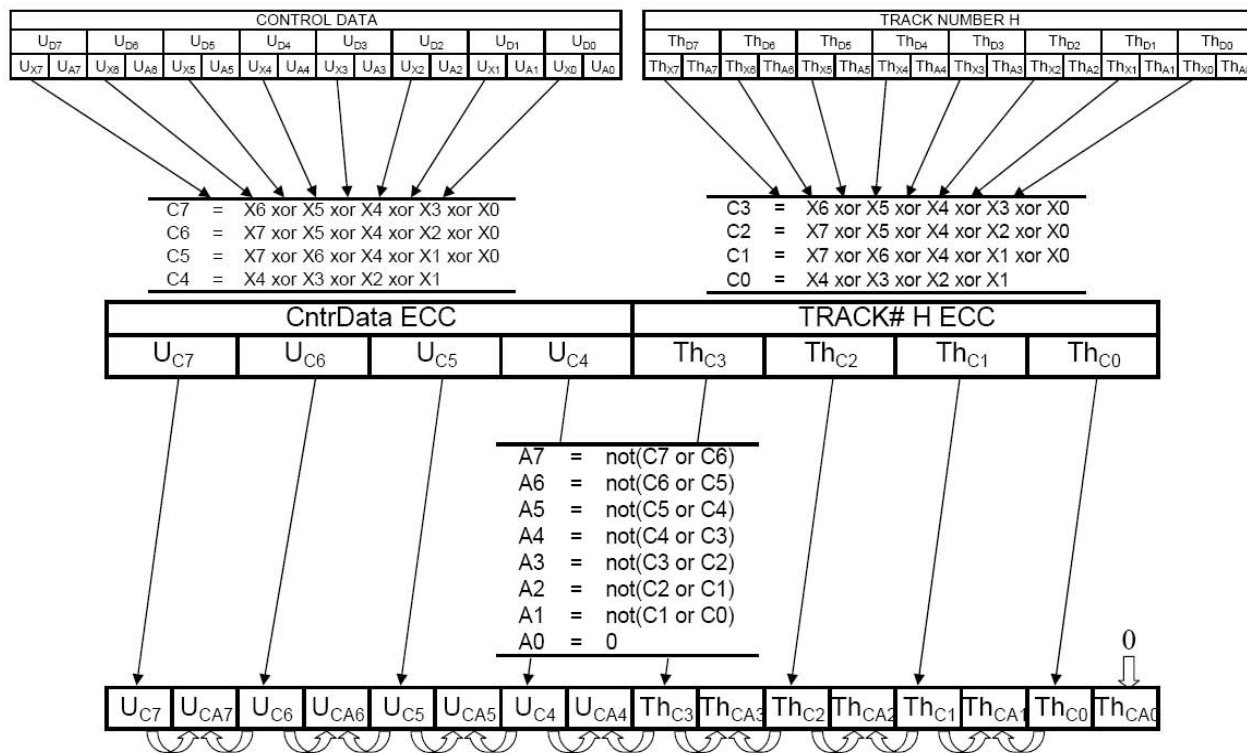

Figure 21.a – Generation of higher digits of ECC data

The lower digits of ECC data bits shall be generated as shown in Figure 21.b.

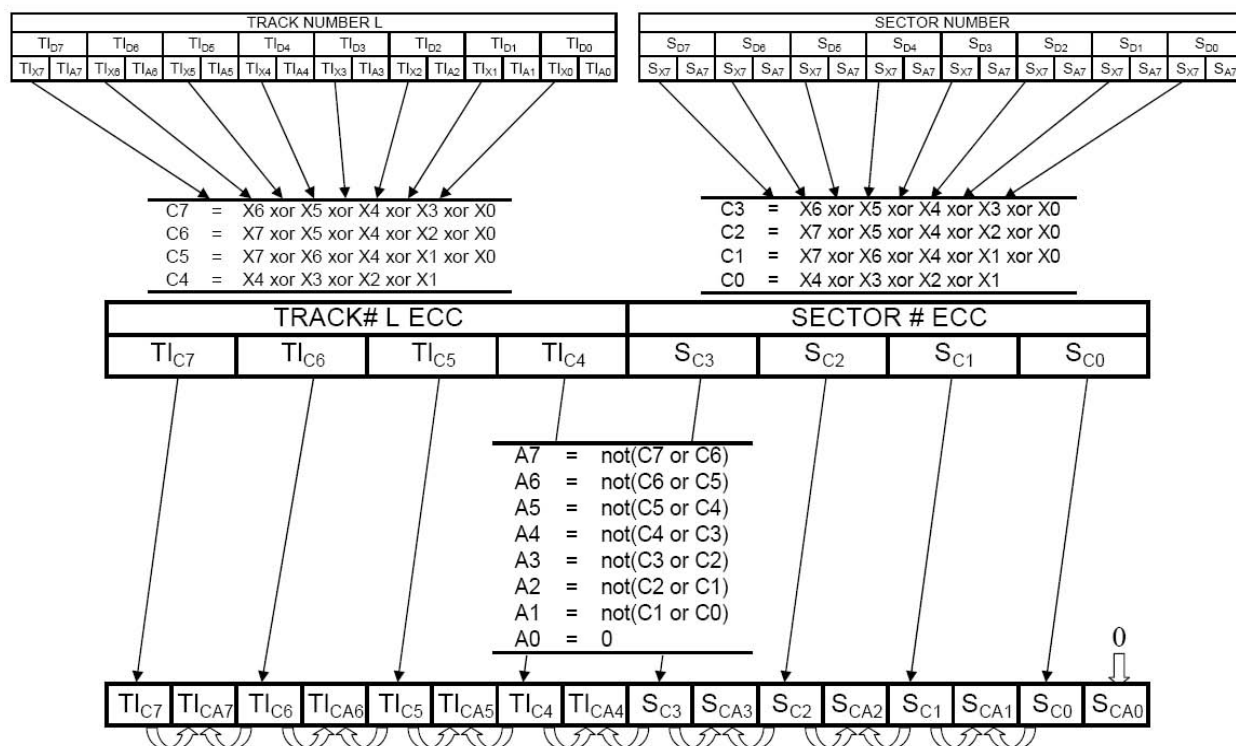

Figure 21.b – Generation of lower digits of ECC data

#### 14.2.2.4 Reserved field

The reserved field shall be a blank space of 40 Channel bits length.

The reserved field shall be ignored in interchange.

#### 14.2.3 Sync

This field shall have a 40 channel bits length and shall consist of a 3T/16T/16T/5T land/pit pattern, as shown on Figure 22.

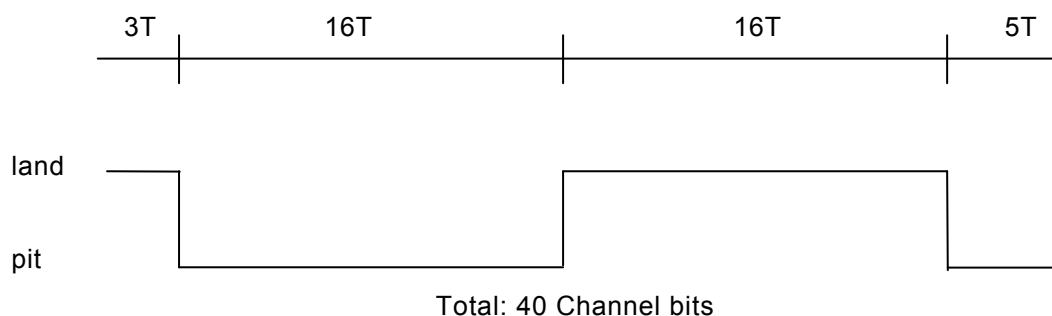
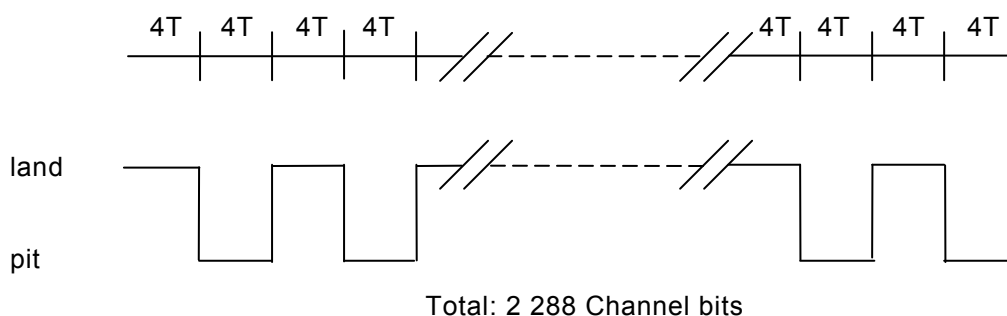

Figure 22 – Sync field pattern

#### 14.2.4 Tracking data

This field shall have a 2 288 channel bits length and shall consist of a 4T land / 4T pit pattern, starting with a 4T land as shown on Figure 23.



*Figure 23 – Tracking data pattern*

#### 14.2.5 Land

Each Sector shall finish with a land field with a length of 8 Channel bits.

### 14.3 Specific Disk Information (SDI)

The Specific Disk Information (SDI) shall be recorded in the tracking data area of the Lead-in tracks of the pit layer, as specified in Annex H.

#### 14.3.1 SDI bytes encoding

The encoding of the SDI bytes shall be processed as shown on Figure 24.

The encoded bits shall be represented by pits and lands of the pit tracks.

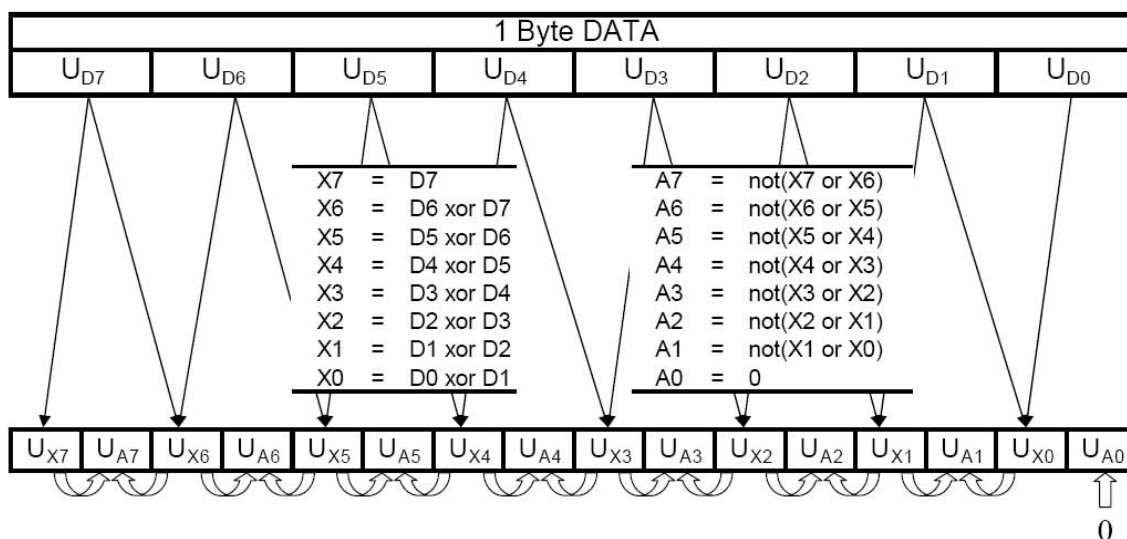

*Figure 24 – SDI bytes encoding*

### 14.4 Channel bits radial alignment

The misalignment  $\delta$  of the Channel bits of adjacent tracks, as defined on Figure 25, shall be less than  $\pm 50$  nm.



*Figure 25 – Channel bit alignment*

## 15 Data information format

The data information shall be stored in the form of holograms in the volume of the recording layer. Each hologram shall contain a Data Page of information.

### 15.1 Data Page holograms layout in the recording layer

All hologram layout format characteristics shall be specified in reference to the pit layer, as access to the information in the holographic recording layer is defined through the tracking/addressing features of the pit layer. The hologram track address shall be in particular designated by the corresponding pit track address.

#### 15.1.1 Radial Data Page hologram pitch

The radial Data Page hologram pitch, the hologram track pitch, shall correspond to 4 pit track pitches.

#### 15.1.2 Data Page hologram layout within tracks

The holograms shall be recorded in each track through  $n$  successive disk rotations, as shown on Figure 26, where numbers correspond to the sequential order of recorded holograms. The series of  $n$  holograms recorded that way shall constitute a "Peapod".

Once all 840 Peapods of a track have been recorded, the recording shall be continued the same way on the following track.

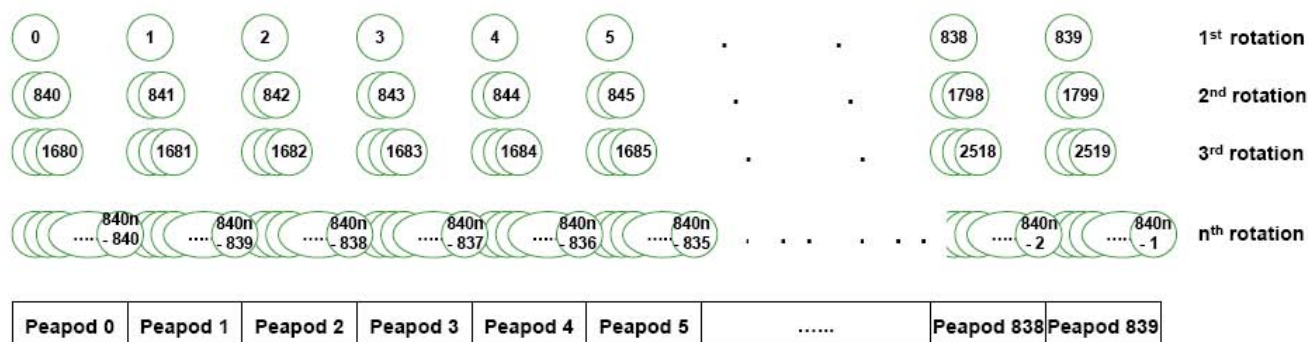

Figure 26 – Data Page holograms layout in a hologram track

#### 15.1.3 Zones / Tangential Data Page hologram pitch / Number of Data Page holograms per Peapod

The holograms shall be exclusively recorded in the tracking data area of the track. Within this area the tangential Data Page hologram pitch shall be the same in Zones defined in Table 1. This pitch shall vary from 12 to 4 Channel bit periods depending on the Zone.

The centre of holograms shall coincide with passages to Zero of the Channel bit period signal. The centre of the first hologram in a track shall coincide with the third transition of the pit signal in the tracking data area (see Figure 27).

The number of Data Page holograms per Peapod shall vary from Zone to Zone, as shown in Table 1.

At each rotation a hologram shall be recorded in each Peapod until all available space is filled. The number of holograms recorded in the last (7<sup>th</sup>) Peapod of each Sector (see Table 1) shall be reduced due to the smaller tracking data area space available for this Peapod at the end of each Sector.



Table 1 – Zones with different tangential Data Page hologram pitches

Zone	Start pit track number	End pit track number	Number of pit tracks	Start address	End address	Number of hologram tracks	Tangential hologram pitch (Number of Channel bit periods)	Holograms per Peapod	
								Peapods* 0,1, ... 5 7, 8, ... 12 ..... 833, 834,... 838	Peapods** 6, 13, ..... 839
0	- 1 280	- 1	1 280	(FB00)	(FFFF)	47***	12	30	10
1	0	1 279	1 280	(0000)	(04FF)	320	8	45	15
2	1 280	2 559	1 280	(0500)	(09FF)	320	8	45	15
3	2 560	3 839	1 280	(0A00)	(0EFF)	320	8	45	15
4	3 840	5 119	1 280	(0F00)	(13FF)	320	8	45	15
5	5 120	6 399	1 280	(1400)	(18FF)	320	8	45	15
6	6 400	7 679	1 280	(1900)	(1DFF)	320	8	45	15
7	7 680	8 959	1 280	(1E00)	(22FF)	320	8	45	15
8	8 960	10 239	1 280	(2300)	(27FF)	320	8	45	15
9	10 240	11 519	1 280	(2800)	(2CFF)	320	8	45	15
10	11 520	12 799	1 280	(2D00)	(31FF)	320	8	45	15
11	12 800	14 079	1 280	(3200)	(36FF)	320	8	45	15
12	14 080	15 359	1 280	(3700)	(3BFF)	320	8	45	15
13	15 360	16 639	1 280	(3C00)	(40FF)	320	4	90	30
14	16 640	17 919	1 280	(4100)	(45FF)	320	4	90	30
15	17 920	18 879	960	(4600)	(49BF)	240	4	90	30
16	18 880	18 891	12	(49C0)	(49CB)	3	4	90	30

NOTES: \* First six Peapods of Sectors.

\*\* Last seventh Peapods of Sectors

\*\*\* Only a part of Zone 0 is used to store holograms (see 16.2.1).

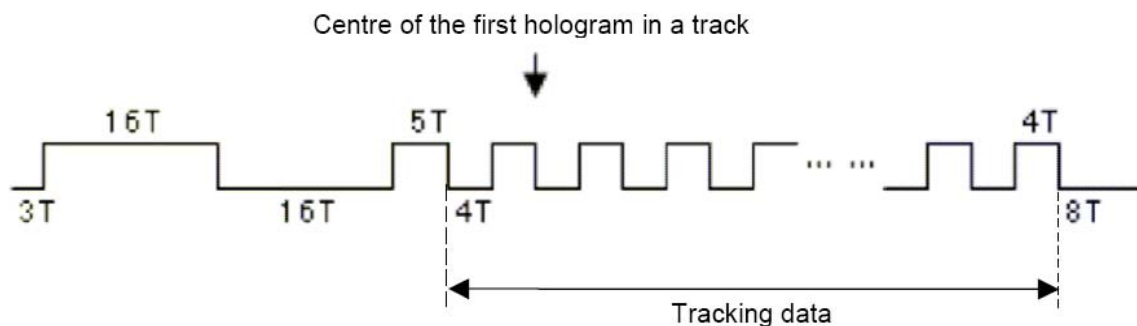

Figure 27 – Position of the first Data Page hologram in a track

## 15.2 Data Page encoding

### 15.2.1 User data

The user data bytes shall be processed as shown on Figure 28 to generate the content of the Data Page of the hologram.

Each 192 512 user data bytes shift shall be formatted in 188 packets of 1 024 bytes (see Figure 29).

These bytes shall be processed by addition of Header, Footer, Inter-Page ECC, Page number, Intra-Page ECC, scrambling to generate the content of the Data Page holograms.

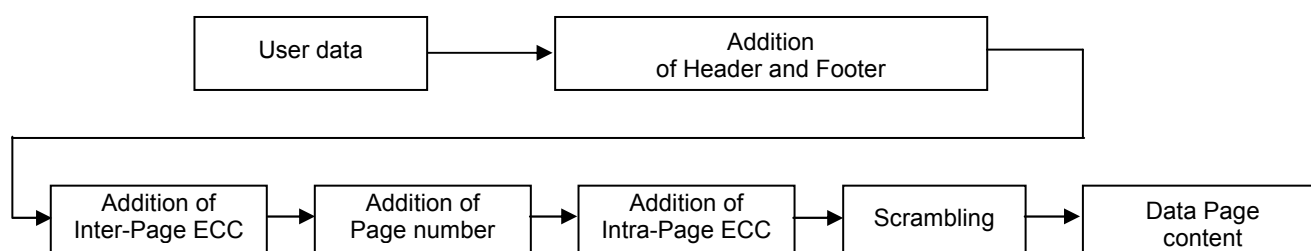

Figure 28 – Data Page encoding

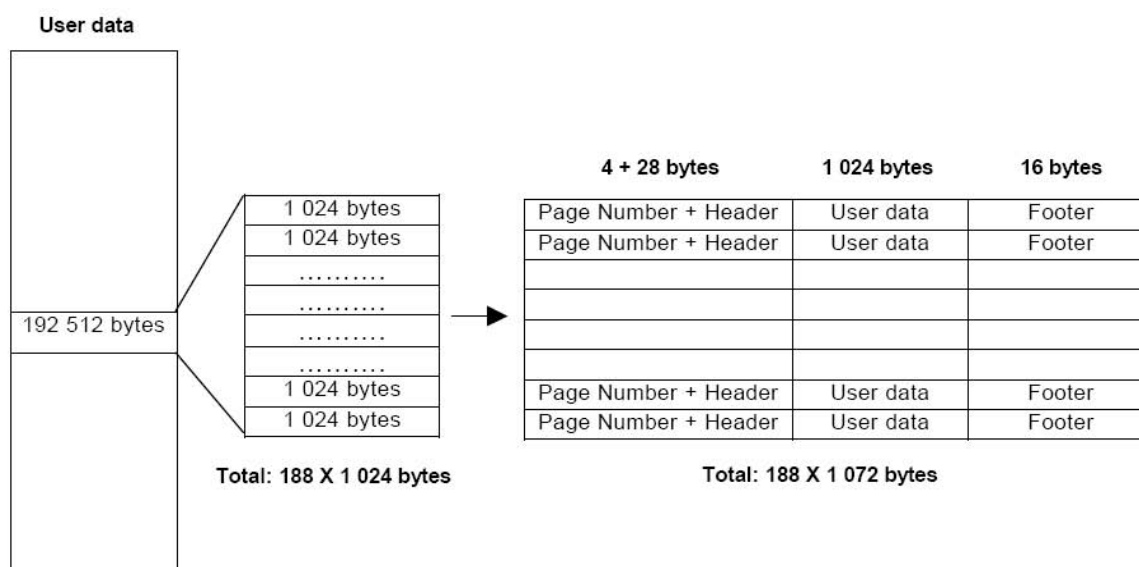

Figure 29 – Addition of Page number, Header and Footer

### 15.2.2 Header

28 bytes Header shall be added to each 1 024 user bytes packet (See Figures 28 and 29).

These bytes shall be set to ZERO. They shall be ignored in interchange.

### 15.2.3 Footer

16 bytes Footer shall be added to each 1 024 user bytes packet (See Figures 28 and 29).

These bytes shall be set to ZERO. They shall be ignored in interchange.

### 15.2.4 ECC

Error Correction Code (ECC) bytes are used by the error detection and correction system to rectify erroneous data in Data Pages.

### 15.2.4.1 Inter-Page ECC

The 1 068 bytes of 188 user data packets constituted of Header + User data + Footer shall be processed by a Reed-Solomon code, as specified in Annex I1, to generate 20 packets of 1 068 Inter-Page ECC bytes, as shown on Figure 30.

### 15.2.4.2 Page number

4 bytes sequential Page numbers shall be added to each of the preceding 188+20 = 208 packets. Page number 0 shall be given to the first Page at inner diameter. Page numbers shall be incremented by one for each following Page.

### 15.2.4.3 Intra-Page ECC

The 1 072 bytes of each of the here above 208 packets shall be processed as specified in Annex I2 to generate 560 Intra-Page ECC bytes that shall be added to each of these 1 072 bytes to constitute the 1 632-bytes content of the Data Page, as shown on Figure 30.

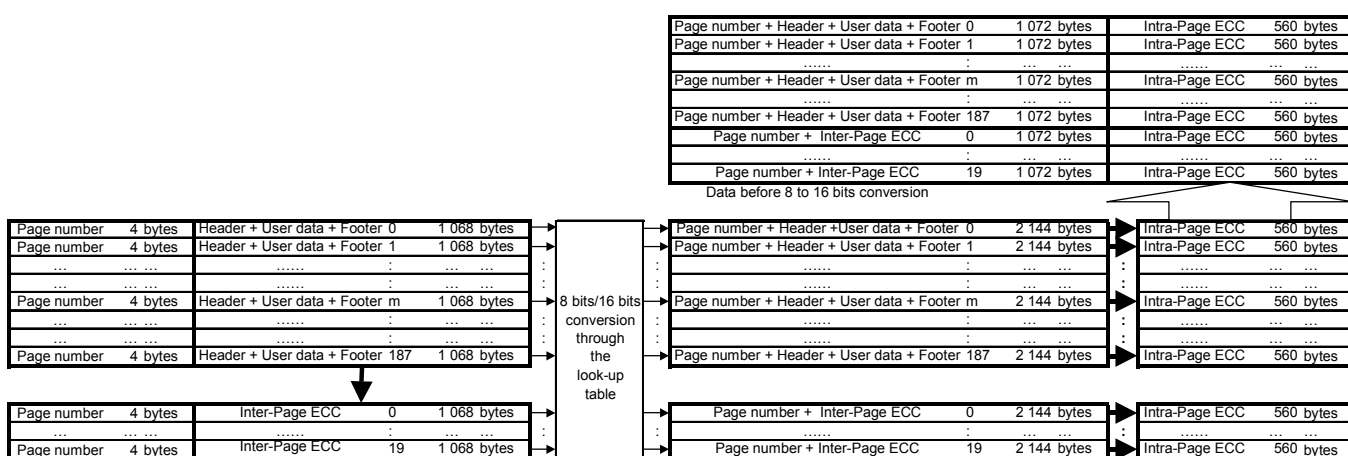

Figure 30 – Inter-Page and Intra-Page ECC codes

### 15.2.5 Scrambling

The 1 632-bytes Data Page content shall be scrambled by means of the circuit shown in Figure 31 which shall consist of a feedback bit shift register in which bits  $r_7$  (msb) to  $r_0$  (lsb) represent a scrambling byte at each 8-bit shift. The scrambling shall start at the beginning of each every 208 Pages, with pre-set values of positions  $r_{14}$  to  $r_0$  of the shift register as specified in Figure 31.

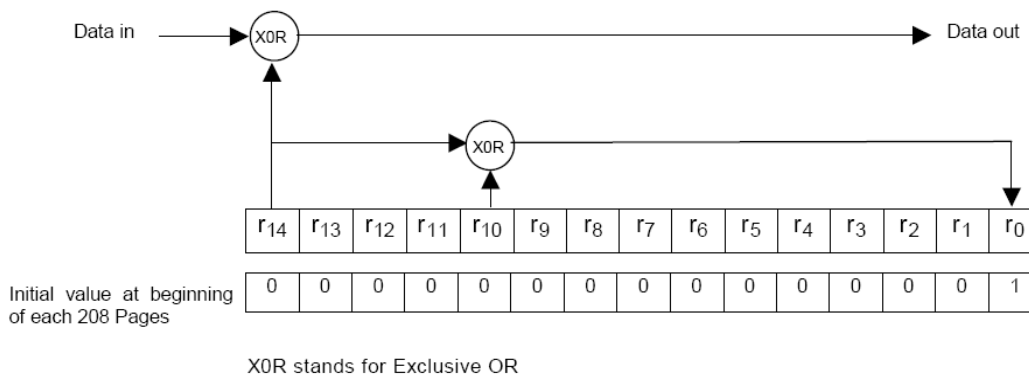

Figure 31 – Feedback shift register for generating the scrambling bytes

### 15.3 Digital to image conversion

#### 15.3.1. 8 to 16 bits conversion

Each of the 1 632 bytes corresponding to the content of a page shall be transformed to 2x1 632 bytes by a 8 to 16 bits conversion using the look-up table shown on Figure 32.

This conversion shall be such that three 1's shall appear within each successive 16 bits.

Each 1 632 obtained bytes shall represent the hologram recorded content of a Data Page (see Figure 33).

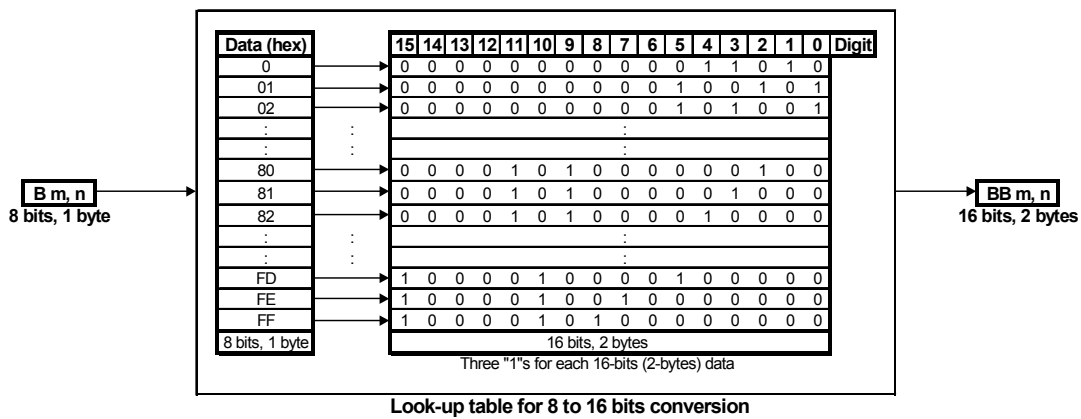

Figure 32 – 8 to 16 bits conversion

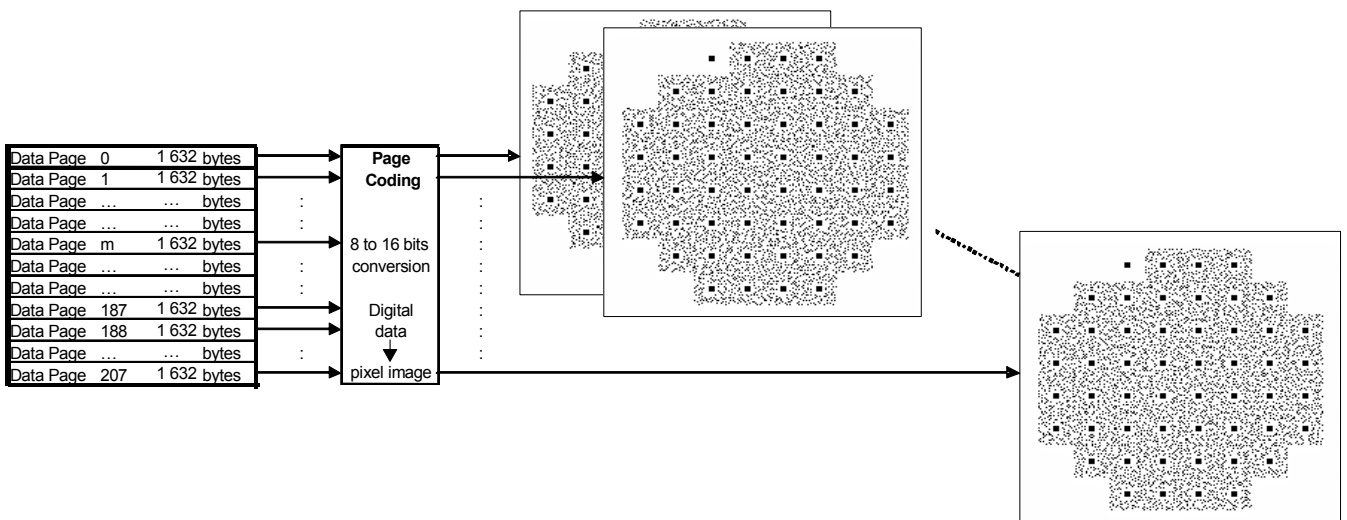

Figure 33 – Data Page image generation

### 15.3.2 Symbol/Sub-Page

After the 8 to 16 bits conversion, each 16 bits shall be represented in the Data Page by a 4X4 On/Off-pixels Symbol, as illustrated on Figure 34, using the look-up table of Annex J. Bits to One shall correspond to On (illuminated) - pixels of the Data Page. Bits to Zero shall correspond to Off (non-illuminated) - pixels of the Data Page.

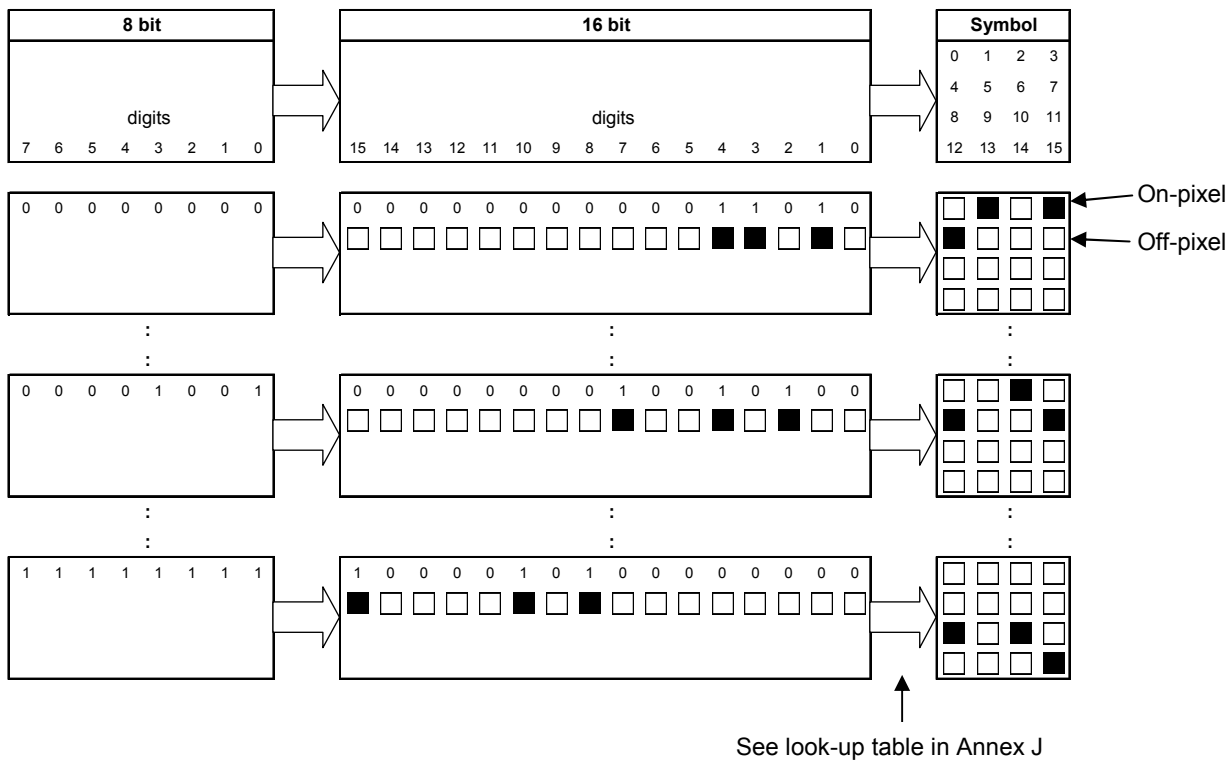

Figure 34 – Data Page pixel symbols representation after 8 to 16 bits conversion

A Sub-Page Sync Mark constituted of 16 On-pixels shall be added to 32 Symbols to constitute the Sub-Page image that shall be organized as shown on Figure 35.

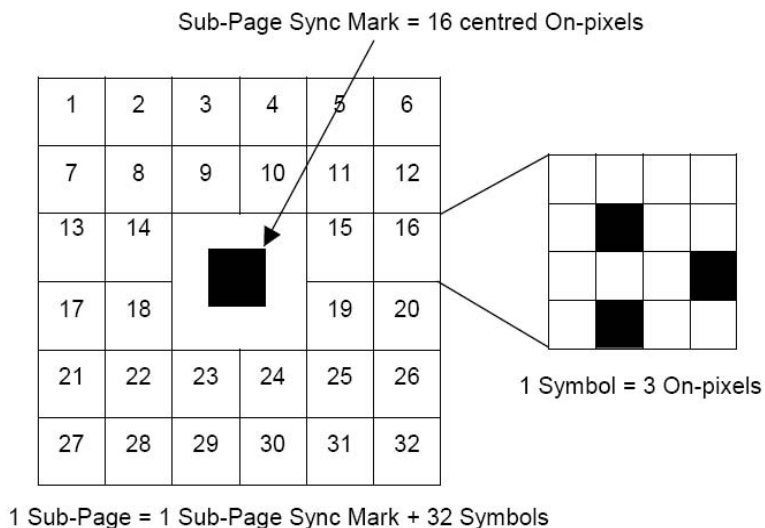
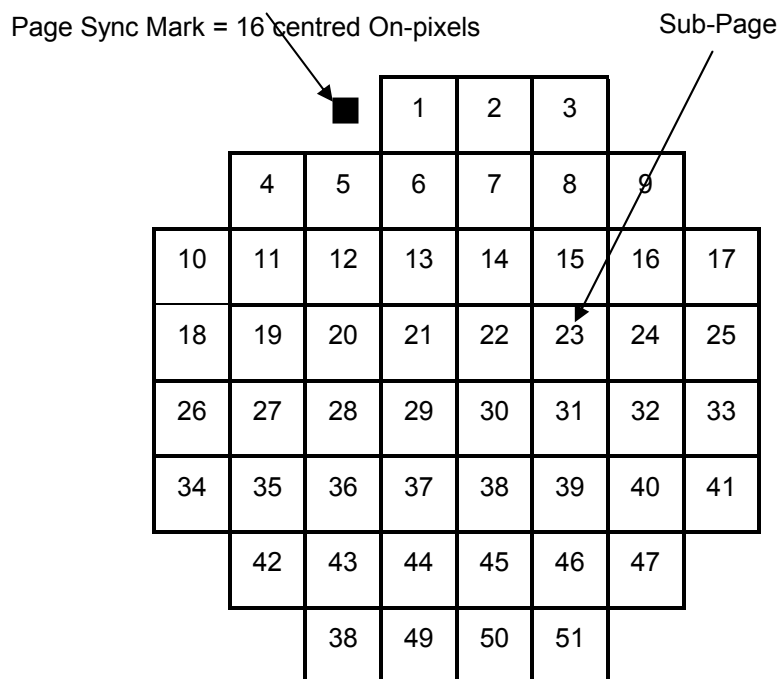

Figure 35 – Pixel Symbols organization of the content of a Sub-Page

A Page Sync Mark constituted of 16 On-pixels shall be added to 51 Sub-Pages to generate the Data Page image that shall be organized as shown on Figure 36.



1 Page = 1 Page Sync Mark + 51 Sub-Pages = 1 632 bytes

*Figure 36 – Sub-Page organization of a Page*

#### 15.4 Data Page hologram - Reference Pattern

The Data Page image generated as specified in 15.3.2 shall be recorded as a hologram in the recording layer with the Reference Pattern shown in Figure 37.

This pattern shall be constituted of 120 radial lines of On-pixels generated by the spatial light modulator. The inner and outer diameters shall be 230 and 358 pixels. The width of the lines shall be 1 pixel.

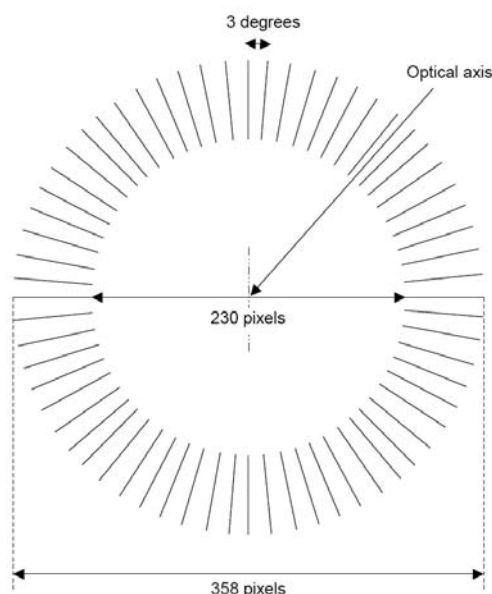

*Figure 37 – Reference Pattern used to record the hologram of the Data Page*

## 16 Formatted Zone

### 16.1 General description of the Formatted Zone

The Formatted Zone contains all information on the disk relevant for data interchange. This information comprises tracking/addressing/SDI provisions, and possibly user written data. In this clause the term "data" is reserved for the content of the data field of a Data Page, which, in general, is transferred to the host.

Clause 16 defines the layout of the information. The characteristics of signals obtained from this information are specified in sections 4 and 6.

### 16.2 Content/usage of the Formatted Zone

The Formatted Zone shall be structured and used as shown in Table 2.

Table 2 – Content/usage of the Formatted Zone

Content / usage	Zone number(s)	Pit track addresses (Decimal)	Pit track addresses (Hexadecimal)	Number of pit tracks	Number of hologram tracks
Lead-in Zone	0	-1 280 to -831	(FB00) to (FCC1)	450	....
Buffer Zone 1	0	-830 to -511	(FCC2) to (FE01)	320	...
Test Zone	0	-510 to -321	(FE02) to (FEBF)	190	47
Buffer Zone 2	0	-320 to -1	(FEC0) to (FFFF)	320	....
User data Zone	1 to 15	0 to 18 879	(0000) to (49BF)	18 880	4720
Lead-out Zone	16	18 880 to 18 891 <sup>1</sup>	(49C0) to (49CB)	12	3

#### 16.2.1 Zone 0 – Lead-in Zone / Buffer Zone 1 / Test Zone / Buffer Zone 2

The Zone 0 shall be divided in 4 Sub-Zones

##### 16.2.1.1 Lead-in Zone

The Lead-in Zone shall be used for storing the SDI. The Lead-in Zone shall comprise 450 pit tracks.

##### 16.2.1.2 Buffer Zone 1

The Buffer Zone 1 shall comprise 320 pit tracks.

##### 16.2.1.3 Test Zone

The Test Zone shall be used for write/read tests. The Test Zone shall comprise 190 pit tracks corresponding to 47 hologram tracks.

##### 16.2.1.4 Buffer Zone 2

The Buffer Zone 2 shall comprise 320 pit tracks.

#### 16.2.2 Zones 1 to 15 - User data Zone

Zones 1 to 15 shall constitute the User data Zone used to record user data.

The User data Zone shall comprise 18 880 pit tracks corresponding to 4720 hologram tracks that may contain 191 520 000 holograms recording 173 104 615 user Data Pages.

The first user hologram on the disk shall be recorded centred on pit Track 0.

### 16.2.3 Zone 16 - Lead-out Zone

The Lead-out Zone shall be used to record finalizing data. The Lead-out Zone shall comprise 12 pit tracks corresponding to 3 hologram tracks.

## 17 Finalizing

---

Finalizing of the recorded disk shall be performed in recording the data specified in Annex K in a Data Page recorded repetitively in the 3 hologram tracks of the Lead-out Zone. After finalizing no further recording shall be permitted.

## Section 4 - Characteristics of the tracking/addressing and SDI information

## 18 Method of testing

---

The format of the pit tracking/addressing and SDI information on the disk is defined in Clause 14. Clause 19 specifies the requirements for the signals from the tracks, addresses and SDI, as obtained when using the Reference Drive specified in Clause 9.

### 18.1 Environment

All signals specified in Clause 19 shall be within their specified ranges with the cartridge in any environment in the range of allowed operating environments defined in 8.1.2.

### 18.2 Use of the Reference Drive

All signals specified in Clause 19 shall be measured in the indicated channel of the Reference Drive. The drive shall have the following characteristics for the purpose of these tests.

#### 18.2.1 Optics and mechanics

The drive shall have a Tracking/Addressing Channel, with the implementation as given in 9.2.

The tracking/addressing beam shall have the properties defined in 9.2.1.

The disk shall rotate as specified in 9.5.5.

#### 18.2.2 Tracking/addressing beam power

The tracking/addressing beam power shall be  $0,5 \text{ mW} \pm 0,2 \text{ mW}$ .

#### 18.2.3 Tracking requirements

During the measurement of the signals, the focus of the beam shall follow the pit track with the requirements defined in Clause 9.5.1.

### 18.3 Definition of signals

Figure 38 shows the signals specified in Clause 19.

All signals are linearly related to currents  $I_1$  and  $I_2$  derived from the outputs of the split photodiode detector of the Reference Drive (see 9.1), and are therefore linearly related to the optical power falling on the detector.

The reading signal  $I$  provided by the Addressing Channel is the high bandwidth sum signal

$$I = I_1 + I_2$$

as processed by the band-pass filter described in Annex L.1.



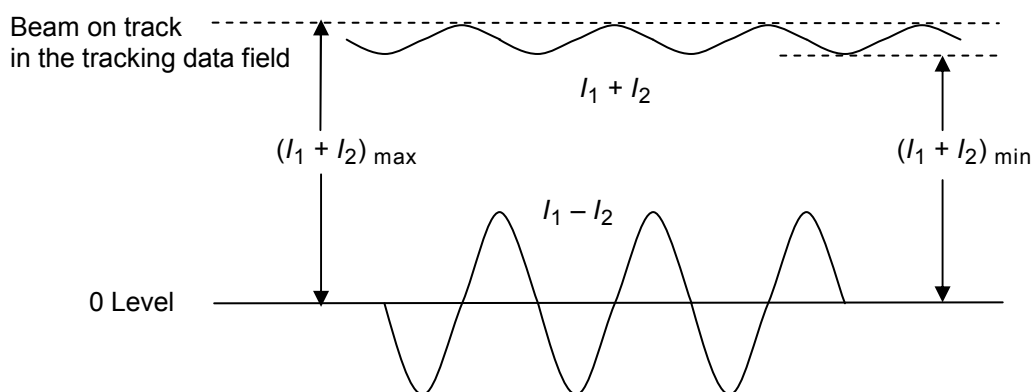

Figure 38a – Signals from the tracking data field

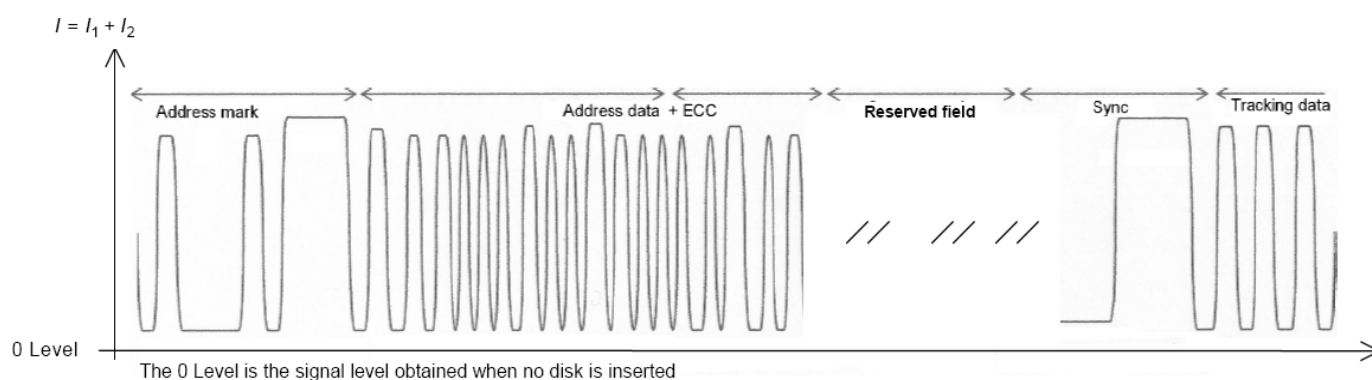

Figure 38b – Signal  $I = I_1 + I_2$  in the different fields

Figure 38 – Illustration of the various parameters for tracking/addressing signal characteristics

## 19 Signal requirements

### 19.1 Reflectivity

The reflectivity is defined as the ratio of the upper level of signal  $I = I_1 + I_2$  obtained from a 4T land to the signal  $I = I_1 + I_2$  obtained from a totally reflecting disk.

The reflectivity shall not be less than 18%.

### 19.2 Normalized Push Pull signal

The push-pull signal is the sinusoidal difference signal  $(I_1 - I_2)$  in the Radial Tracking Channel, when the focus of the optical beam crosses the tracks. This signal can be used as error signal for radial tracking. The normalized peak-to-peak value of the push-pull signal shall meet the following requirement in the Formatted Zone:

$$0,4 \leq \frac{(I_1 - I_2)_{PP}}{(I_1 + I_2)_{av}} \leq 0,8$$

### 19.3 Modulation

The modulation of signal  $I = I_1 + I_2$  is the ratio of its average peak-to-peak value to its average top value.

$$\text{Modulation} = \frac{(I_1 + I_2)_{PP}}{(I_1 + I_2)_{top\ av}}$$

The modulation shall not be less than 0,3 for the tracking data 4T marks.

### 19.4 Resolution

The resolution  $I_{nT} / I_{mT}$  is the ratio of the average peak-to-peak value  $I_{nT}$  of the signal obtained from nT pits and nT lands to the average peak-to-peak value of the signal  $I_{mT}$  obtained from mT pits and mT lands.

$$\text{Resolution } I_{nT} / I_{mT} = \frac{I_{nT\ PP\ av}}{I_{mT\ PP\ av}}$$

The resolution  $I_{2T} / I_{4T}$  shall not be less than 0,5 for the address data or ECC 2T pits and tracking data 4T pits.

The resolution  $I_{16T} / I_{4T}$  shall not be less than 0,5 for the Sync 16T pits and tracking data 4T pits.

### 19.5 4Ttop modulation

The 4Ttop modulation is the ratio of the peak-to-peak variation value of the upper envelope of the signal obtained from 4T pits to its maximum upper level value.

$$4Ttop\ modulation = \frac{(I_{4T\ top})_{PP}}{(I_{4T\ top})_{max}}$$

The 4T top modulation shall be less than 10% on a disk revolution.

### 19.6 Asymmetry

The asymmetry (see Annex M) relates to the deviation of the centre levels of the signals of two distinct repeating pit and land patterns.

#### 19.6.1 Asymmetry (4T - 2T)

The asymmetry (4T - 2T) shall be less than  $\pm 10\%$  for the address data or ECC 2T pits and tracking data 4T pits.

#### 19.6.2 Asymmetry (16T - 4T)

The asymmetry (16T - 4T) shall be less than  $\pm 10\%$  for the Sync 16T pits and tracking data 4T pits.

### 19.7 Jitter

Jitter is the standard deviation (sigma) of the time variation of the digitized data.

The jitter of the 4T pits and lands, measured as a percentage of the nominal pits and lands durations, shall be less than 8%.

### 19.8 Phase depth

The phase depth of pits

$$\frac{n \times d}{\lambda_T} \times 360^\circ$$

where n is the index of refraction of the cover layer, d is the pit depth, and  $\lambda_T$  is the wavelength of the tracking/addressing laser, shall be less than 90°.

## Section 5 - Characteristics of the recording layer

### 20 Method of testing

---

Clause 21 describes tests to assess the optical properties of the recording layer, as used for writing data. The write read operations necessary for the tests shall be made on the same Reference Drive.

#### 20.1 Environment

The requirement of Clause 21 shall be obtained with the cartridge in any environment in the range of allowed operating environments defined in 8.1.1.

#### 20.2 Reference Drive

The write tests described in Clause 21 shall be measured in the Data Reading Channel of the Reference Drive. The drive shall have the following characteristics for the purpose of these tests.

##### 20.2.1 Optics and mechanics

The reference drive shall have Tracking/Addressing Channel and Data holographic Recording and Reading Channel as given in 9.2, 9.3 and 9.4.

The Reference Pattern used to record and read the data image shall be as specified in 15.4.

The disk shall rotate as specified in 9.5.5.

##### 20.2.2 Data recording energy

The data recording energy shall be as specified in the SDI (see Annex H).

##### 20.2.3 Data reading energy

The data reading energy shall be as specified in the SDI (see Annex H).

##### 20.2.4 Tracking requirements

During the measurement of the signals, the focus of the tracking/addressing beam shall follow the pit track with the requirements defined in 9.5.1.

##### 20.2.5 Relative positioning of the focus of the data recording/reading beam and the tracking/addressing beam

During data recording/reading, the relative positioning of the centres of the focus of the data recording/reading beam and the tracking/addressing beam shall be as specified in 9.5.2 and 9.5.3.

##### 20.2.6 Data detection for testing purposes

Data shall be detected for testing purposes as specified in Annex L.2.

#### 20.3 Writing conditions

##### 20.3.1 Write pulse

Pages are recorded on the disk by pulses of optical energy  $E_W$  at the test rotational frequency.

The write pulse energy  $E_W$  shall be as specified in the SDI.

The measurement of laser energy shall be done in pulsed operation by averaging. The averaging method of measuring the laser power will minimize the accumulation of pulse width and pulse amplitude tolerances. The media manufacturer shall determine the value of the pulse energy levels  $E_W$  that are recorded in the SDI.

The maximum energy level used for recording on any disk at any radius shall not exceed 5,0  $\mu\text{J}/\text{pulse}$ .

##### 20.3.2 Write pulse energy determination

The media manufacturer shall determine the value of the write pulse energy levels parameters.

The write parameters recorded in the SDI shall generate written data that complies with the requirement of Clause 21.

## 21 Recording layer characteristics requirements

---

The recording layer characteristics shall be such that Data Pages written and read with conditions conforming to Clauses 20 shall not contain any byte errors that cannot be corrected by the error correction circuit.

## 22 Holographic material characteristics

---

### 22.1 Read energy damage

Stored data shall not become damaged due to the repetitive reading of pages. Media shall be tested against reading energy damage.

No error shall appear after ECC decoding after 1 million readouts.

## Section 6 - Characteristics of user data

## 23 User data – Method of testing

---

Clauses 23 and 24 describe measurements to test conformance of the user data on the disk with this Ecma Standard. It checks the legibility of user written data. The user written data is assumed to be arbitrary. The user written data may have been written by any drive in any environment. The read tests shall be performed on the Reference Drive.

The requirements in Clauses 24 and 25 define a minimum quality of the data, necessary for data interchange.

### 23.1 Environment

All specifications of Clauses 24 and 25 shall be verified with the cartridge in any environment in the range of allowed operating environments defined in 8.1.1.

### 23.2 Reference Drive

All specifications of Clauses 24 and 25 shall be measured in the Reference Drive. The drive shall have the following characteristics for the purpose of these tests:

#### 23.2.1 Optics and mechanics

The reference drive shall have Tracking/Addressing and Reading Channels as given in 9.2 and 9.4.

The Reference Pattern used to read the data image shall be as specified in 15.4.

The disk shall rotate as specified in 9.5.5.

#### 23.2.2 Tracking/addressing reading power

The tracking/addressing reading power shall be  $0,5 \text{ mW} \pm 0,2 \text{ mW}$ .

#### 23.2.3 Data energy

The data reading energy shall be as specified in the SDI (see Annex H).

#### 23.2.4 Tracking requirements

During the measurement of the signals, the focus of the tracking/addressing beam shall follow the pit track with the requirements defined in 9.5.1.

#### 23.2.5 Relative positioning of the focus of the data reading beam and the tracking/addressing beam

During data reading, the relative positioning of the centres of the focus of the data reading beam and the tracking/addressing beam shall be as specified in Clause 9.5.3.

#### **23.2.6 Data detection for testing purposes**

Data shall be detected for testing purposes as specified in Annex L.2.

### **24 Minimum quality of a Data Page**

---

This clause specifies the minimum quality of a Data Page as required for interchange of the data contained in that page. The quality shall be measured on the Reference Drive specified in 23.2.

A byte error occurs when one or more bits in a byte have a wrong setting, as detected by ECC circuits.

The written data in a Data Page shall not contain any byte errors that cannot be corrected by the error correction circuit.

### **25 Data interchange requirements**

---

A disk offered for interchange of data shall comply with the following requirements.

#### **25.1 Tracking**

The focus of the optical beam shall not jump pit tracks unintentionally.

#### **25.2 User-written data**

Data for interchange shall be written anywhere within the User data Zone.

#### **25.3 User-read data**

Any recorded Page shall not contain byte errors during reading, after the error correction circuit.



## Annex A (normative)

### Edge distortion test

#### A.1 Purpose

---

The distortion test checks if the case is free from unacceptable distortion and protrusions along its edges. The test is made by causing the cartridge to pass through the vertical slot of a gauge while applying a specified force in addition to the gravitational pull.

#### A.2 Distortion gauge construction

---

The gauge shall be made of a suitable material, e.g. of chrome-plated carbon steel. The inner surfaces shall be polished to a surface finish of 5  $\mu\text{m}$  peak-to-peak.

#### A.3 Distortion gauge dimensions

---

The dimensions shall be as follows (see Figure A.1):

$A = 155,0 \text{ mm}$

$B = 136,0 \text{ mm} \pm 0,1 \text{ mm}$

$C = 10,0 \text{ mm} \pm 0,1 \text{ mm}$

$D = 11,40 \text{ mm} \pm 0,01 \text{ mm}$

$E = 11,60 \text{ mm min.}$

#### A.4 Requirement

---

When the cartridge is inserted vertically into the gauge, a vertical downward force  $F$  of 2,7 N maximum, applied to the centre of the top edge of the cartridge, shall cause the cartridge to pass through the gauge.

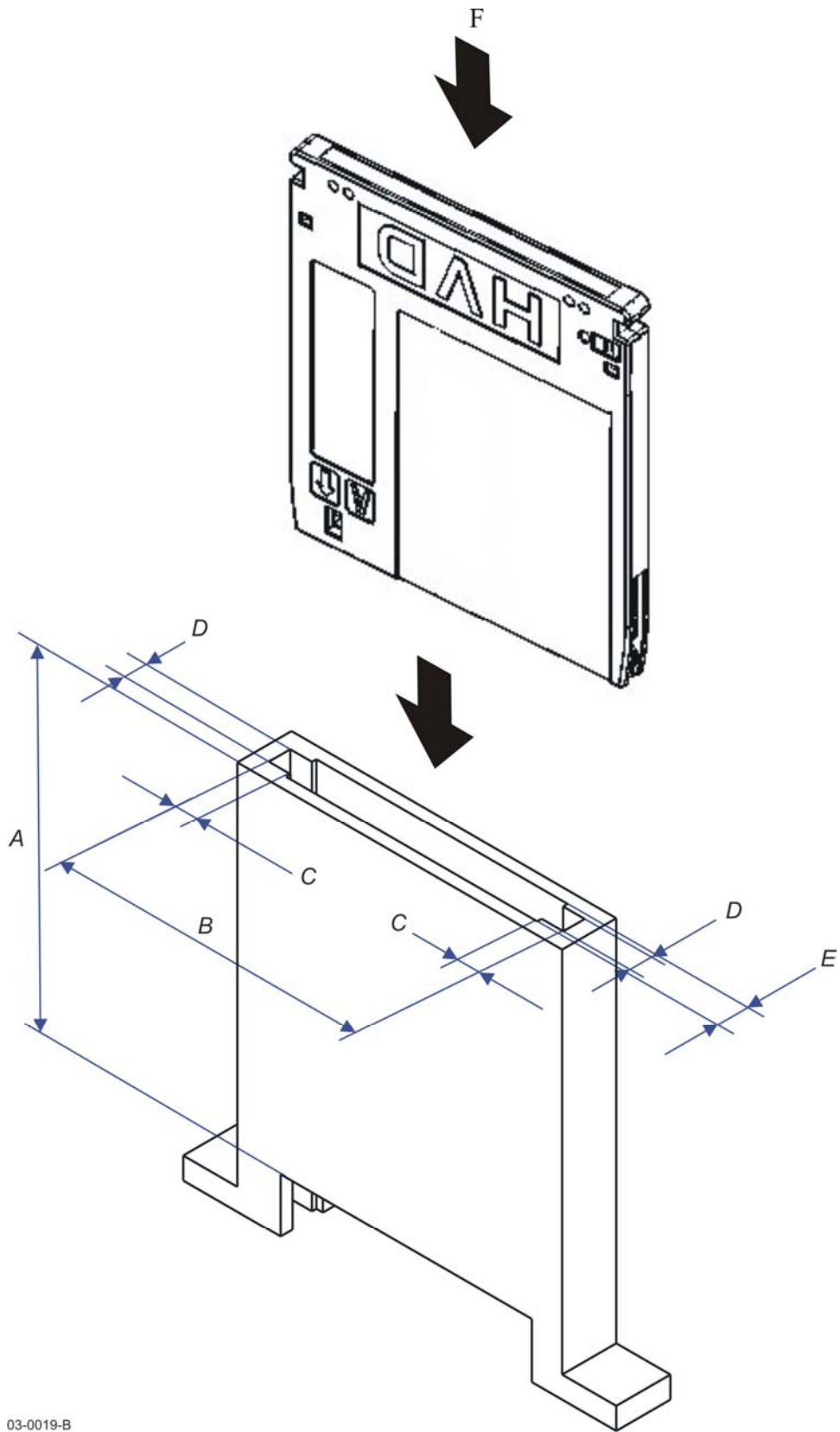

03-0019-B

Figure A.1 – Distortion gauge



## Annex B (normative)

### Compliance test

#### B.1 Purpose

---

The compliance test checks the flatness and flexibility of the case by forcing the four reference surfaces of the cartridge into a plane.

#### B.2 Reference surfaces

---

The location of the four reference surfaces S1, S2, S3, and S4 is defined in 10.4.4 and Figure 4.

#### B.3 Compliance gauge

---

The test gauge consists of a base plate on which four posts P1, P2, P3, and P4 are fixed so as to correspond to the surfaces S1, S2, S3, and S4 respectively (see Figure B.1). The dimensions are as follows (see Figures B.2 and B.3):

$$L_a = 122,0 \text{ mm} \pm 0,2 \text{ mm}$$

$$L_b = 133,0 \text{ mm} \pm 0,5 \text{ mm}$$

$$L_c = 110,0 \text{ mm} \pm 0,5 \text{ mm}$$

$$D_a = 6,50 \text{ mm} \pm 0,01 \text{ mm}$$

$$D_b = 4,00 \text{ mm} \begin{array}{l} + 0,00 \text{ mm} \\ - 0,02 \text{ mm} \end{array}$$

$$D_c = 5,50 \text{ mm} \pm 0,01 \text{ mm}$$

$$H_a = 1,0 \text{ mm} \pm 0,1 \text{ mm}$$

$$H_b = 2,0 \text{ mm max.}$$

After assembly, the upper annular surfaces of the four posts shall lie between two horizontal planes spaced 0,01 mm apart.

#### B.4 Test conditions

---

The cartridge shall be placed with its reference surfaces onto the posts of the horizontal gauge. A vertical down force  $F$  of 0,4 N shall be exerted on the cartridge opposite each of the four posts.

#### B.5 Requirement

---

Under the conditions of B.4, any three of the four surfaces S1 to S4 shall be in contact with the annular surface of respective posts. Any gap between the remaining surface S and the annular surface of its post shall not exceed 0,1 mm.

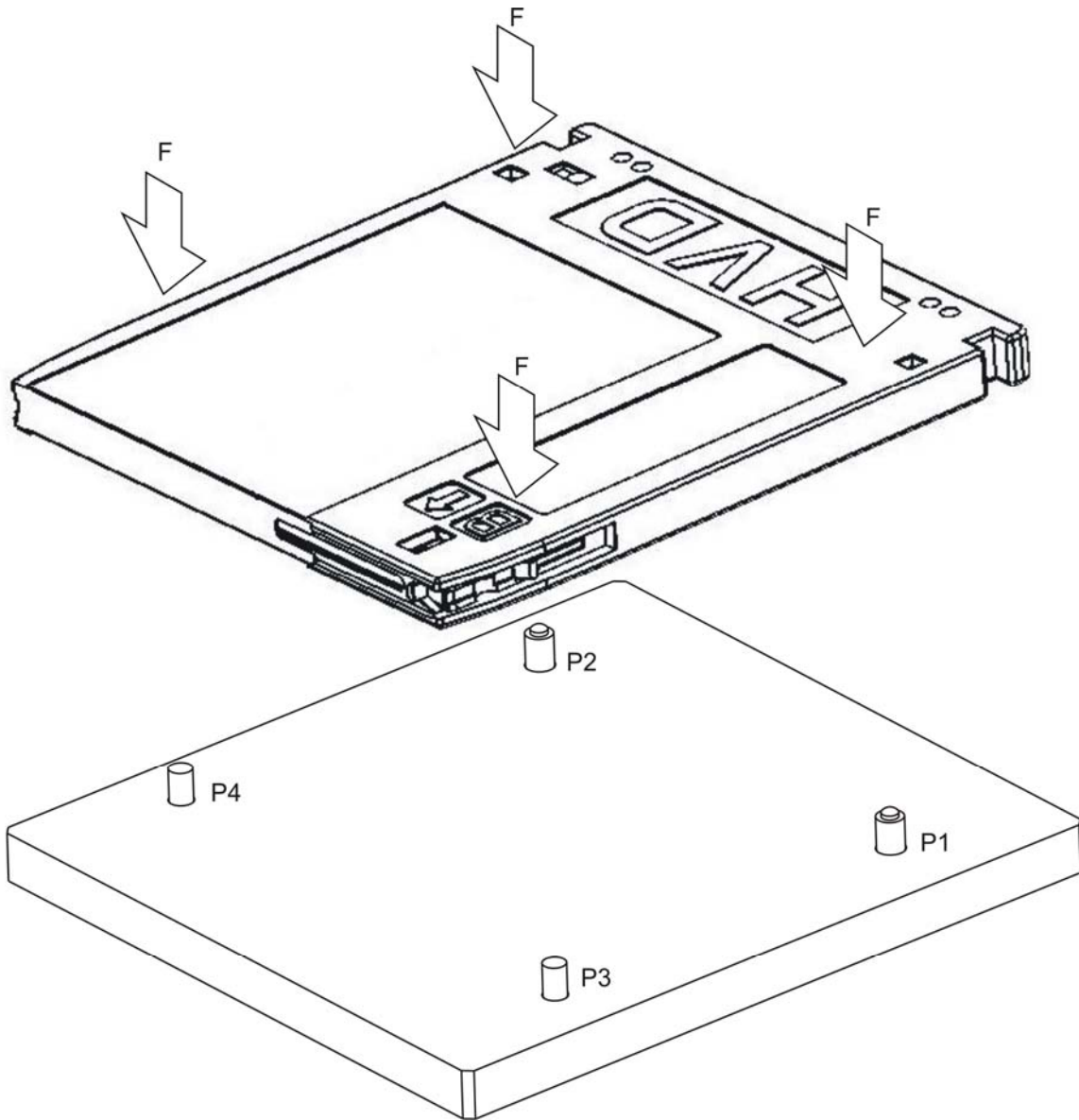

03-0021-A

*Figure B.1 – Compliance gauge*

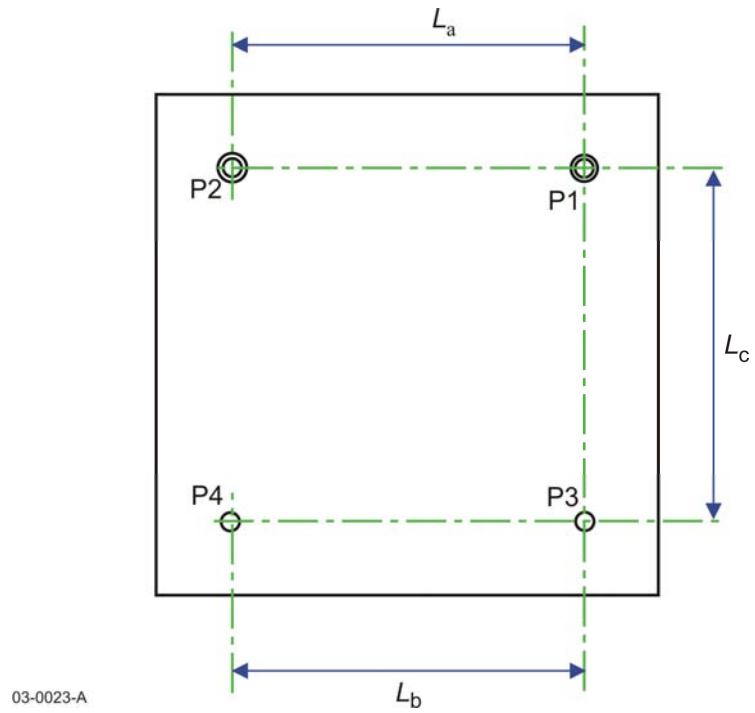

Figure B.2 – Location of the posts

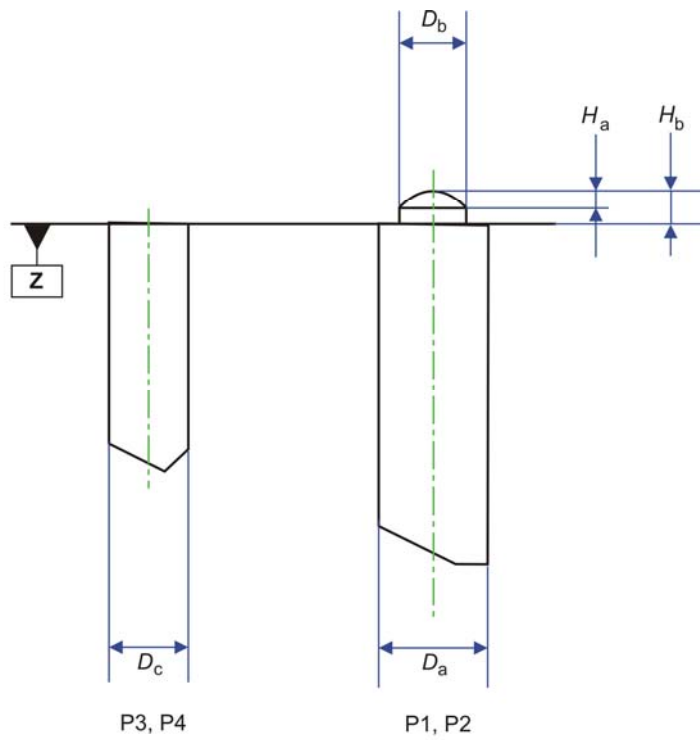

Figure B.3 – Detail of the posts



## **Annex C** **(normative)**

### **Cartridge light-proof test**

All cartridge specifications must be fulfilled, after illumination test of the cartridge with an air-cooled Xenon lamp used under conditions (hereafter) complying with the ISO 105-B02 Standard.

Test conditions:

- Black Panel Temperature: < 40 °C
- Relative humidity: 70% - 80%
- Disk inside of case
- Duration of illumination: Such that the European Blue Wool Reference #5 shows a contrast between exposed and unexposed portions equal to grey scale grade 3 (see ISO 105-A02 Standard)

Remark:

The change in colour of the cartridge is irrelevant for this test.



## Annex D (normative)

### Electro-static discharge test

#### D.1 Test procedure

The test procedure shall use the following steps:

- 1 Acclimate test cartridges at 10 % relative humidity for at least 12 hours before testing.
- 2 Remove all charge from the test cartridge using ionized air.
- 3 Mount the cartridge in the fixture shown in Figure D.1.
- 4 Apply 1,00 kV to the charge plate.
- 5 10 seconds  $\pm$  1 second after applying 1,00 kV, remove the voltage source (charge plate is floating).
- 6 Measure the decay time defined as the time required for the charged plate voltage to decay 5 % to 950 V.

Prior to testing a cartridge, ensure there is a non-ionizing environment by performing steps 4 - 6 above with no cartridge present. Decay time with no cartridge shall be larger than 100 seconds.

#### D.2 Specification

The decay time shall be smaller than 30 seconds at 10 % relative humidity and 25 °C.

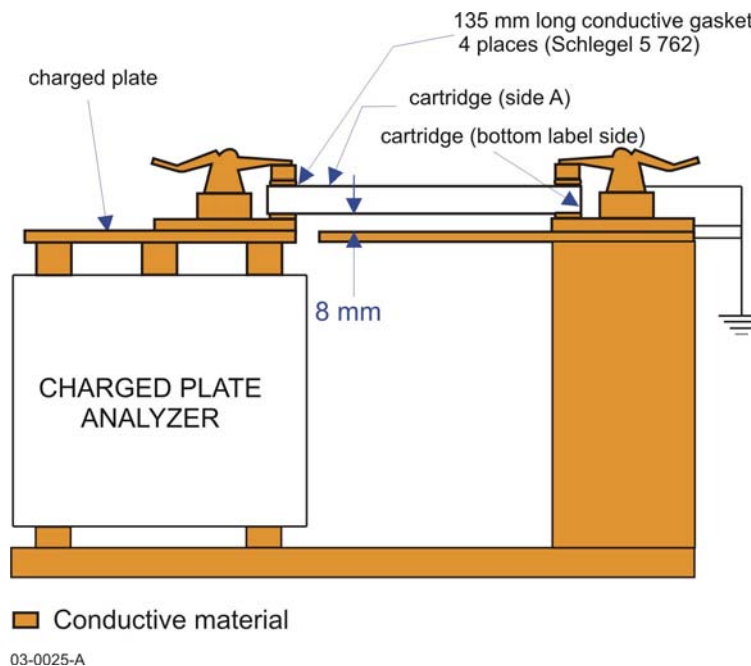

Figure D.1 – Cartridge electro-static discharge test fixture





## Annex E (normative)

### Measurement of light reflectance

#### E.1 Calibration method

A good reference disk shall be chosen, for instance a glass disk with a golden reflective mirror. This reference disk shall be measured by a parallel beam as shown in Figure E.1

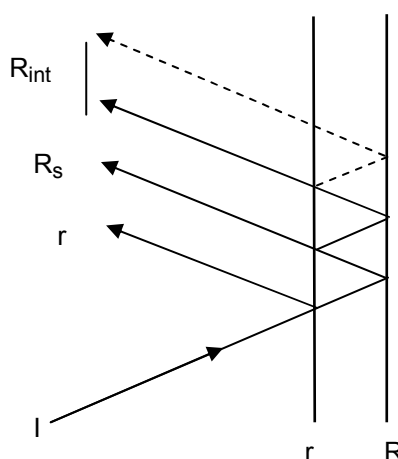

*Figure E.1 - Reflectance calibration*

In this figure the following applies.

$I$  = incident beam

$r$  = reflectance of the entrance surface

$R_s$  = main reflectance of the measured reflective layer

$R_{int}$  = other reflectance's of the entrance surface and of the measured reflective layer

$R_{//}$  = measured value, using the arrangement of Figure E.1

$$R_{//} = r + R_s + R_{int}$$

$$r = \frac{(n-1)^2}{(n+1)^2} \quad \text{where } n \text{ is the refraction index of the cover layer}$$

$$R_s = R_{//} - r - R_{int}$$

$$R_s = \frac{[(1-r)^2 \times (R_{//} - r)]}{[1-r \times (2 - R_{//})]}$$

The reference disk shall be measured on a reference drive and  $I_{mirror}$  measured by the focused beam is equated to  $R_s$  as determined above.

Now the arrangement is calibrated and the focused reflectivity is a linear function of the reflectivity of the measured reflective layer, independently from the reflectivity of the entrance surface.

## E.2 Measuring method

---

The measuring method comprises the following steps.

- a) Measure the reflective light power  $D_s$  from the reference disk with calibrated reflectivity  $R_s$
- b) Measure  $I_{xx}$  in a defined area of the disk.
- c) Calculate the reflectivity as follows

$$R_{xx} = R_s \times \frac{I_{xx}}{D_s}$$

## Annex F (normative)

### Measurement of birefringence

#### F.1 Principle of the measurement

In order to measure the birefringence, circularly polarized light in a parallel beam is used. The phase retardation is measured by observing the ellipticity of the reflected light.

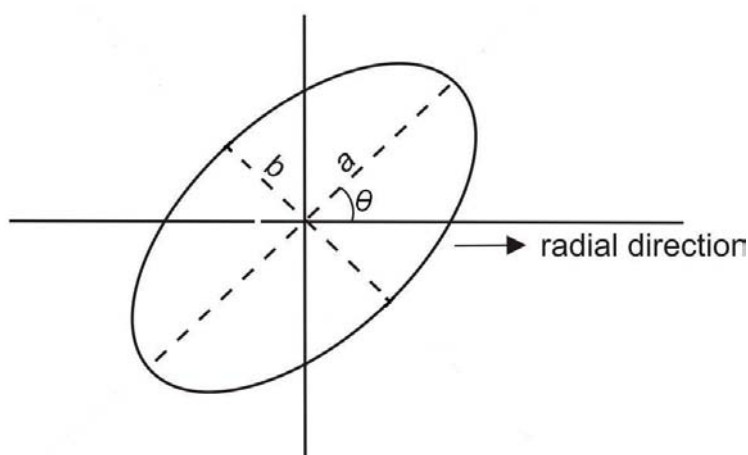

97-0008-A

*Figure F.1 - Ellipse with ellipticity  $e = b/a$  and orientation  $\theta$*

The orientation  $\theta$  of the ellipse is determined by the orientation of the optical axis

$$\theta = \gamma - \pi/4 \quad (I)$$

where  $\gamma$  is the angle between the optical axis and the radial direction.

The ellipticity  $e = b/a$  is a function of the phase retardation  $\delta$

$$e = \tan \left[ \frac{1}{2} \left( \frac{\pi}{2} - \delta \right) \right] \quad (II)$$

When the phase retardation  $\delta$  is known the birefringence  $BR$  can be expressed as a fraction of the wavelength

$$BR = \frac{\lambda}{2\pi} \delta \text{ nm} \quad (III)$$

Thus, by observing the elliptically polarized light reflected from the disk, the birefringence can be measured and the orientation of the optical axis can be assessed as well.

#### F.2 Measurements conditions

The measurement of the birefringence specified above shall be made under the following conditions:

Mode of measurement

in reflection, double pass through the specified stack of layers

Wavelength $\lambda$ of the laser light	$\lambda_T$ or $\lambda_R$ nm $\pm$ 15 nm
Beam diameter (Full width half maximum)	1,0 mm $\pm$ 0,2 mm
Angle $\beta$ of incidence in radial direction relative to the radial plane perpendicular to Reference Plane P	7,0° $\pm$ 0,2°
Clamping and chucking conditions	as specified in 12.2 and 12.3
Disk mounting	horizontally
Rotation	less than 1 Hz
Temperature and relative humidity	as specified in 8.1.1

### F.3 Example of a measuring set-up

Whilst this Ecma Standard does not prescribe a specific device for measuring birefringence, the device shown schematically in Figure F.2 as an example, is well suited for this measurement.

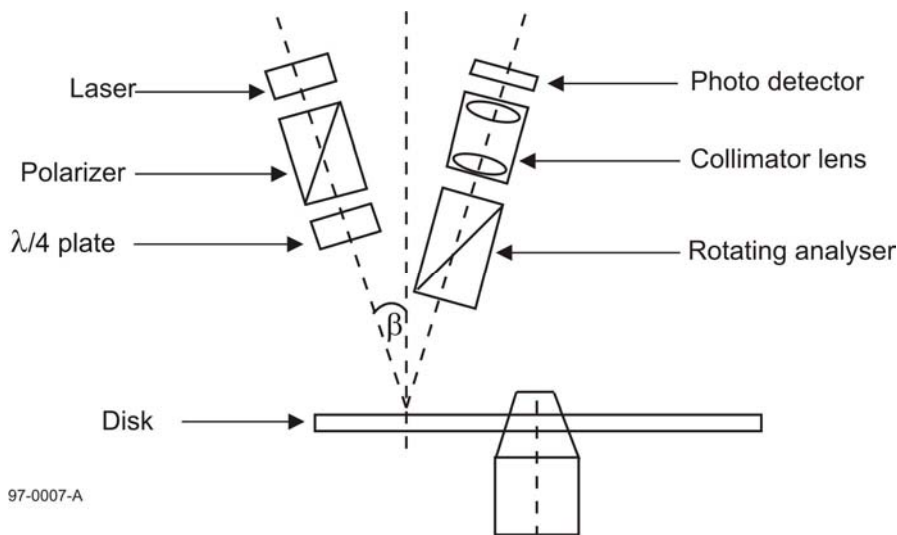

Figure F.2 - Example of a device for the measurement of birefringence

Light from a laser source, collimated into a polarizer (extinction ratio  $\approx 10^{-5}$ ), is made circular by a  $\lambda/4$  plate. The ellipticity of the reflected light is analyzed by a rotating analyser and a photo detector. For every location on the disk, the minimum and the maximum values of the intensity  $I$  are measured.

The ellipticity can then be calculated as

$$e^2 = I_{\min} / I_{\max} \quad (IV)$$

Combining equations II, III and IV yields

$$BR = \lambda / 4 - \lambda / \pi \times \arctang \sqrt{\frac{I_{\min}}{I_{\max}}}$$

This device can be easily calibrated as follows

- $I_{\min}$  is set to 0 by measuring a polarizer or a  $\lambda/4$  plate,
- $I_{\min} = I_{\max}$  when measuring a mirror

Apart of the d.c. contribution of the front surface reflection, a.c. components may occur, due to the interference of the reflection(s) of the front surface with the reflection(s) from the internal layers. These a.c. reflectance effects are significant only if the disk substrate has an extremely accurate flatness and if the light source has a high coherence.



## Annex G (normative)

### Tapered cone for disk clamping

The device used for centring the disk for measurement shall be a cone with a taper angle  $\beta = 40,0^\circ \pm 0,5^\circ$  (see Figure G.1).

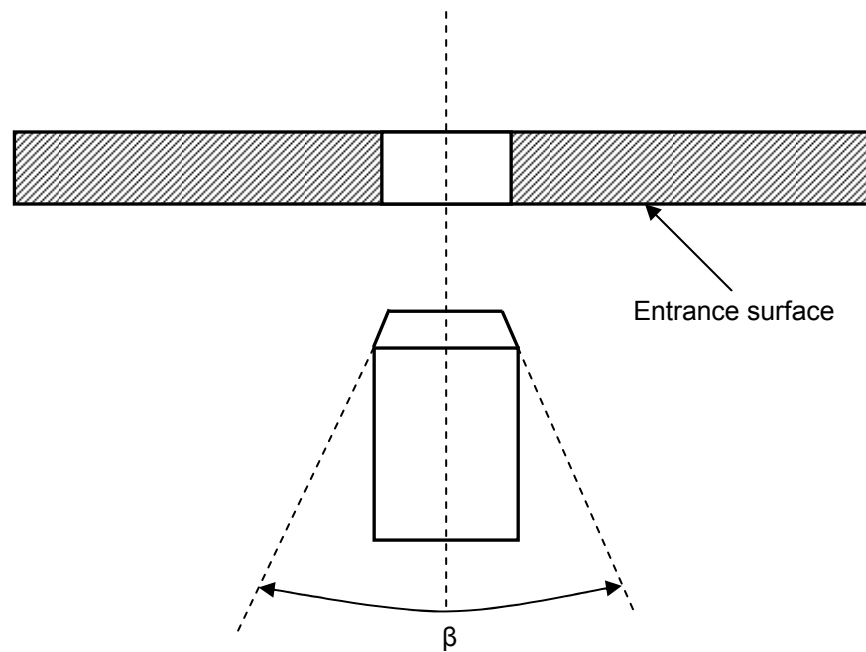

Figure G.1 - Tapered cone





## **Annex H** (normative)

### **Specific Disk Information**

The Specific Disk Information (SDI) recorded in the tracking data area of the Lead-in tracks shall contain the items/parameters listed in Tables H.1 and H.2.

Format, number of bytes and position in the tracks of each item/parameter shall be as specified in the tables.

The energy  $E_w$  used to write the holograms shall be as specified in Table H.2 versus Track, Sector, Rotation and Peapod.

Table H.1 – SDI content

Pit Track number		Pit Sector number		Start Channel bit *		Items	Format / Meaning	Bytes
DEC	HEX	DEC	HEX	DEC	HEX			
-1 280	FB00	0	00	224	00E0	Version of disk format	1 / HVD-R 200GB	2
				256	0100	Version of Specific Disk	n / (Version n) x 100	2
				288	0120	Disk category	1 / HVD-R	2
				320	0140	Disk size	1 / 120 mm	2
				352	0160	Disk capacity	n / n Gbytes	2
				384	0180	Reserved	Set to Zero	10
				544	0220	Energy density for permanent	n / n	2
				576	0240	Reserved	Set to Zero	2
				608	0260	Hologram read energy	n / n nanoJoules	2
				640	0280	Write strategy	1 / Sequential	1
				656	0290	Reserved	Set to Zero	22
				1 008	03F0	Hologram write energy Ew	n / n nanoJoules	94
				2 512	09D0			
				1	01	224	00E0	Reserved
		240	00F0			Hologram write energy Ew	n / n nanoJoules	142
		2 512	09D0					
		2	02	224	00E0	Reserved	Set to Zero	1
				240	00F0	Hologram write energy Ew	n / n nanoJoules	142
				2 512	09D0			
		⋮	⋮	⋮	⋮	⋮	⋮	⋮
199	C7	224	00E0	Reserved	Set to Zero	1		
		240	00F0	Hologram write energy Ew	n / n nanoJoules	142		
		2 512	09D0					
-1 279	FB01	0	00	224	00E0	Repeat of Channel bits 224 to 655		27
				656	0290	Hologram write energy Ew	n / n nanoJoules	116
				2 512	09D0			
		1	01	224	00E0	Reserved	Set to Zero	1
				240	00F0	Hologram write energy Ew	n / n nanoJoules	142
				2 512	09D0			
		2	02	224	00E0	Reserved	Set to Zero	1
				240	00F0	Hologram write energy Ew	n / n nanoJoules	142
				2 512	09D0			
		⋮	⋮	⋮	⋮	⋮	⋮	⋮
199	C7	224	00E0	Reserved	Set to Zero	1		
		240	00F0	Hologram write energy Ew	n / n nanoJoules	142		
		2 512	09D0					
-1 231	FB31	0	00	224	00E0	Repeat of Channel bits 224 to 655		27
				656	0290	Hologram write energy Ew	n / n nanoJoules	116
				2 512	09D0			
		1	01	224	00E0	Reserved	Set to Zero	1
				240	00F0	Hologram write energy Ew	n / n nanoJoules	142
				2 512	09D0			
		2	02	224	00E0	Reserved	Set to Zero	1
				240	00F0	Hologram write energy Ew	n / n nanoJoules	142
				2 512	09D0			
		⋮	⋮	⋮	⋮	⋮	⋮	⋮
199	C7	224	00E0	Reserved	Set to Zero	1		
		240	00F0	Hologram write energy Ew	n / n nanoJoules	142		
		2 512	09D0					
-1 230	FB32	Repeat of Tracks –1 280 to –1 231						
⋮	⋮							
-1 181	FB63	Repeat of Tracks –1 280 to –1 231						
-1 180	FB64	Repeat of Tracks –1 280 to –1 231						
⋮	⋮							
-1 131	FB95	Repeat of Tracks –1 280 to –1 231						

\* NOTE: The Channel bits in each Sector are numbered from 1 to 2 520.

Table H.2 – Ew SDI content

Zone	Track	Rotation	Sector 0				...			Sector 119			
			Peapod 0	Peapod 1	Peapod 2	Peapod 3	...	...	...	Peapod 836	Peapod 837	Peapod 838	Peapod 839
1	0	0	Ew0	Ew1	Ew2	Ew3	Ew3	Ew3	Ew3	Ew3	Ew4	Ew5	Ew6
		1	Ew7	Ew8	Ew9	Ew10	Ew10	Ew10	Ew10	Ew10	Ew11	Ew12	Ew13
		44	Ew308	Ew309	Ew310	Ew311	Ew311	Ew311	Ew311	Ew311	Ew312	Ew313	Ew314
		44	Ew315	Ew316	Ew317	Ew318	Ew318	Ew318	Ew318	Ew318	Ew319	Ew320	Ew321
	4	1	Ew322	Ew323	Ew324	Ew325	Ew325	Ew325	Ew325	Ew325	Ew326	Ew327	Ew328
		44	Ew623	Ew624	Ew625	Ew626	Ew626	Ew626	Ew626	Ew626	Ew627	Ew628	Ew629
		44	Ew623	Ew624	Ew625	Ew626	Ew626	Ew626	Ew626	Ew626	Ew627	Ew628	Ew629
	316	0	Ew24885	Ew24886	Ew24887	Ew24888	Ew24888	Ew24888	Ew24888	Ew24888	Ew24889	Ew24890	Ew24891
		1	Ew24892	Ew24893	Ew24894	Ew24895	Ew24895	Ew24895	Ew24895	Ew24895	Ew24896	Ew24897	Ew24898
		44	Ew25193	Ew25194	Ew25195	Ew25196	Ew25196	Ew25196	Ew25196	Ew25196	Ew25197	Ew25198	Ew25199
		44	Ew25200	Ew25201	Ew25202	Ew25203	Ew25203	Ew25203	Ew25203	Ew25203	Ew25204	Ew25205	Ew25206
	320	1	Ew25207	Ew25208	Ew25209	Ew25210	Ew25210	Ew25210	Ew25210	Ew25210	Ew25211	Ew25212	Ew25213
		44	Ew25508	Ew25509	Ew25510	Ew25511	Ew25511	Ew25511	Ew25511	Ew25511	Ew25512	Ew25513	Ew25514
		44	Ew25515	Ew25516	Ew25517	Ew25518	Ew25518	Ew25518	Ew25518	Ew25518	Ew25519	Ew25520	Ew25521
	352	1	Ew25522	Ew25523	Ew25524	Ew25525	Ew25525	Ew25525	Ew25525	Ew25525	Ew25526	Ew25527	Ew25528
		44	Ew25823	Ew25824	Ew25825	Ew25826	Ew25826	Ew25826	Ew25826	Ew25826	Ew25827	Ew25828	Ew25829
		44	Ew25823	Ew25824	Ew25825	Ew25826	Ew25826	Ew25826	Ew25826	Ew25826	Ew25827	Ew25828	Ew25829
	1 248	0	Ew34335	Ew34336	Ew34337	Ew34338	Ew34338	Ew34338	Ew34338	Ew34338	Ew34339	Ew34340	Ew34341
		1	Ew34342	Ew34343	Ew34344	Ew34345	Ew34345	Ew34345	Ew34345	Ew34345	Ew34346	Ew34347	Ew34348
		44	Ew34643	Ew34644	Ew34645	Ew34646	Ew34646	Ew34646	Ew34646	Ew34646	Ew34647	Ew34648	Ew34649
		44	Ew34650	Ew34651	Ew34652	Ew34653	Ew34653	Ew34653	Ew34653	Ew34653	Ew34654	Ew34655	Ew34656
	1 280	1	Ew34657	Ew34658	Ew34659	Ew34660	Ew34660	Ew34660	Ew34660	Ew34660	Ew34661	Ew34662	Ew34663
		44	Ew34958	Ew34959	Ew34960	Ew34961	Ew34961	Ew34961	Ew34961	Ew34961	Ew34962	Ew34963	Ew34964
		44	Ew34958	Ew34959	Ew34960	Ew34961	Ew34961	Ew34961	Ew34961	Ew34961	Ew34962	Ew34963	Ew34964
44		Ew34958	Ew34959	Ew34960	Ew34961	Ew34961	Ew34961	Ew34961	Ew34961	Ew34962	Ew34963	Ew34964	
2 528	0	Ew46935	Ew46936	Ew46937	Ew46938	Ew46938	Ew46938	Ew46938	Ew46938	Ew46939	Ew46940	Ew46941	
	1	Ew46942	Ew46943	Ew46944	Ew46945	Ew46945	Ew46945	Ew46945	Ew46945	Ew46946	Ew46947	Ew46948	
	44	Ew47243	Ew47244	Ew47245	Ew47246	Ew47246	Ew47246	Ew47246	Ew47246	Ew47247	Ew47248	Ew47249	
	44	Ew47243	Ew47244	Ew47245	Ew47246	Ew47246	Ew47246	Ew47246	Ew47246	Ew47247	Ew47248	Ew47249	
3 808	0	Ew47250	Ew47251	Ew47252	Ew47253	Ew47253	Ew47253	Ew47253	Ew47253	Ew47254	Ew47255	Ew47256	
	44	Ew59843	Ew59844	Ew59845	Ew59846	Ew59846	Ew59846	Ew59846	Ew59846	Ew59847	Ew59848	Ew59849	
	44	Ew59843	Ew59844	Ew59845	Ew59846	Ew59846	Ew59846	Ew59846	Ew59846	Ew59847	Ew59848	Ew59849	
	44	Ew59843	Ew59844	Ew59845	Ew59846	Ew59846	Ew59846	Ew59846	Ew59846	Ew59847	Ew59848	Ew59849	
5 368	0	Ew72450	Ew72451	Ew72452	Ew72453	Ew72453	Ew72453	Ew72453	Ew72453	Ew72454	Ew72455	Ew72456	
	44	Ew85043	Ew85044	Ew85045	Ew85046	Ew85046	Ew85046	Ew85046	Ew85046	Ew85047	Ew85048	Ew85049	
	44	Ew85043	Ew85044	Ew85045	Ew85046	Ew85046	Ew85046	Ew85046	Ew85046	Ew85047	Ew85048	Ew85049	
	44	Ew85043	Ew85044	Ew85045	Ew85046	Ew85046	Ew85046	Ew85046	Ew85046	Ew85047	Ew85048	Ew85049	
7 648	0	Ew85050	Ew85051	Ew85052	Ew85052	Ew85052	Ew85052	Ew85052	Ew85052	Ew85052	Ew85053	Ew85054	
	44	Ew94045	Ew94046	Ew94047	Ew94047	Ew94047	Ew94047	Ew94047	Ew94047	Ew94047	Ew94048	Ew94049	
	44	Ew94045	Ew94046	Ew94047	Ew94047	Ew94047	Ew94047	Ew94047	Ew94047	Ew94047	Ew94048	Ew94049	
	44	Ew94045	Ew94046	Ew94047	Ew94047	Ew94047	Ew94047	Ew94047	Ew94047	Ew94047	Ew94048	Ew94049	
15 328	0	Ew139050	Ew139051	Ew139052	Ew139052	Ew139052	Ew139052	Ew139052	Ew139052	Ew139052	Ew139053	Ew139054	
	44	Ew148045	Ew148046	Ew148047	Ew148047	Ew148047	Ew148047	Ew148047	Ew148047	Ew148047	Ew148048	Ew148049	
	44	Ew148045	Ew148046	Ew148047	Ew148047	Ew148047	Ew148047	Ew148047	Ew148047	Ew148047	Ew148048	Ew148049	
	44	Ew148045	Ew148046	Ew148047	Ew148047	Ew148047	Ew148047	Ew148047	Ew148047	Ew148047	Ew148048	Ew148049	

Zone	Track	Rotation	Sector 0				...			Sector 119			
			Peapod 0	Peapod 1	Peapod 2	Peapod 3	...	...	...	Peapod 836	Peapod 837	Peapod 838	Peapod 839
13	15 360	0	Ew148050	Ew148051	Ew148052	Ew148052	Ew148052	Ew148052	Ew148052	Ew148052	Ew148053	Ew148054	
		1	Ew148055	Ew148056	Ew148057	Ew148057	Ew148057	Ew148057	Ew148057	Ew148057	Ew148058	Ew148059	
		89	Ew148495	Ew148496	Ew148497	Ew148497	Ew148497	Ew148497	Ew148497	Ew148497	Ew148498	Ew148499	
	15 364	0	Ew148500	Ew148501	Ew148502	Ew148502	Ew148502	Ew148502	Ew148502	Ew148502	Ew148503	Ew148504	
		1	Ew148505	Ew148506	Ew148507	Ew148507	Ew148507	Ew148507	Ew148507	Ew148507	Ew148508	Ew148509	
		89	Ew148945	Ew148946	Ew148947	Ew148947	Ew148947	Ew148947	Ew148947	Ew148947	Ew148948	Ew148949	
	Every 4 tracks	:	:	:	:	:	:	:	:	:	:	:	
		:	:	:	:	:	:	:	:	:	:	:	
		:	:	:	:	:	:	:	:	:	:	:	
	15 548	0	Ew169200	Ew169201	Ew169202	Ew169202	Ew169202	Ew169202	Ew169202	Ew169202	Ew169203	Ew169204	
		1	Ew169205	Ew169206	Ew169207	Ew169207	Ew169207	Ew169207	Ew169207	Ew169207	Ew169208	Ew169209	
		89	Ew169645	Ew169646	Ew169647	Ew169647	Ew169647	Ew169647	Ew169647	Ew169647	Ew169648	Ew169649	
	15 552	0	Ew169650	Ew169651	Ew169652	Ew169652	Ew169652	Ew169652	Ew169652	Ew169652	Ew169653	Ew169654	
		1	Ew169655	Ew169656	Ew169657	Ew169657	Ew169657	Ew169657	Ew169657	Ew169657	Ew169658	Ew169659	
		89	Ew170095	Ew170096	Ew170097	Ew170097	Ew170097	Ew170097	Ew170097	Ew170097	Ew170098	Ew170099	
	15 584	0	Ew170100	Ew170101	Ew170102	Ew170102	Ew170102	Ew170102	Ew170102	Ew170102	Ew170103	Ew170104	
		1	Ew170105	Ew170106	Ew170107	Ew170107	Ew170107	Ew170107	Ew170107	Ew170107	Ew170108	Ew170109	
		89	Ew170545	Ew170546	Ew170547	Ew170547	Ew170547	Ew170547	Ew170547	Ew170547	Ew170548	Ew170549	
	Every 32 tracks	:	:	:	:	:	:	:	:	:	:	:	
		:	:	:	:	:	:	:	:	:	:	:	
		:	:	:	:	:	:	:	:	:	:	:	
	16 320	0	Ew180000	Ew180001	Ew180002	Ew180002	Ew180002	Ew180002	Ew180002	Ew180002	Ew180003	Ew180004	
		1	Ew180005	Ew180006	Ew180007	Ew180007	Ew180007	Ew180007	Ew180007	Ew180007	Ew180008	Ew180009	
		89	Ew180445	Ew180446	Ew180447	Ew180447	Ew180447	Ew180447	Ew180447	Ew180447	Ew180448	Ew180449	
14	16 640	0	Ew180450	Ew180451	Ew180452	Ew180452	Ew180452	Ew180452	Ew180452	Ew180453	Ew180454		
	Every 32 tracks	:	:	:	:	:	:	:	:	:	:		
		:	:	:	:	:	:	:	:	:	:		
17 888	44	Ew198445	Ew198446	Ew198447	Ew198447	Ew198447	Ew198447	Ew198447	Ew198447	Ew198448	Ew198449		
15	17 920	0	Ew198450	Ew198451	Ew198452	Ew198452	Ew198452	Ew198452	Ew198452	Ew198453	Ew198454		
	Every 32 tracks	:	:	:	:	:	:	:	:	:	:		
		:	:	:	:	:	:	:	:	:	:		
18 848	44	Ew211945	Ew211946	Ew211947	Ew211947	Ew211947	Ew211947	Ew211947	Ew211947	Ew211948	Ew211949		
16	18 880	0	Ew211950	Ew211951	Ew211952	Ew211952	Ew211952	Ew211952	Ew211952	Ew211953	Ew211954		
Reserved			Ew211955 to Ew424799										

## Annex I (normative)

### ECC

The codes used to generate the Inter-Page and Intra-Page ECC bytes shall be as specified in this annex.

#### I.1 Inter- Page ECC

The 1 068 bytes of the 188 packets described in Clause 15.2.4.1 shall be processed by a Reed-Solomon code (255, 235, 20) to generate 20 packets of 1 068 Inter-Page ECC bytes, as shown on Figure I.1.

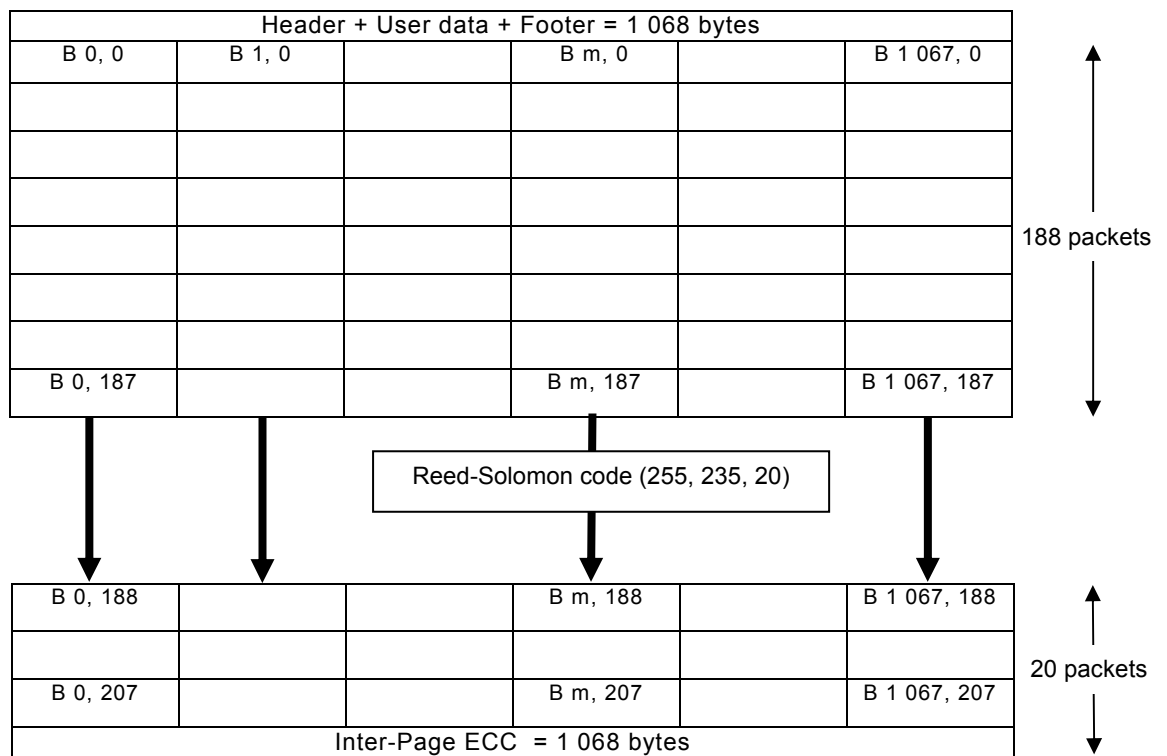

*Figure I.1 – Generation of the Inter-Page ECC bytes*

## I.2 Intra-Page ECC

The 1 072 bytes packets of Clause 15.2.4.1 corresponding to User data + Inter-Page ECC bytes shall be first converted in 2 144 bytes packets through the 8 bits to 16 bits conversion table shown in Figure I.2.

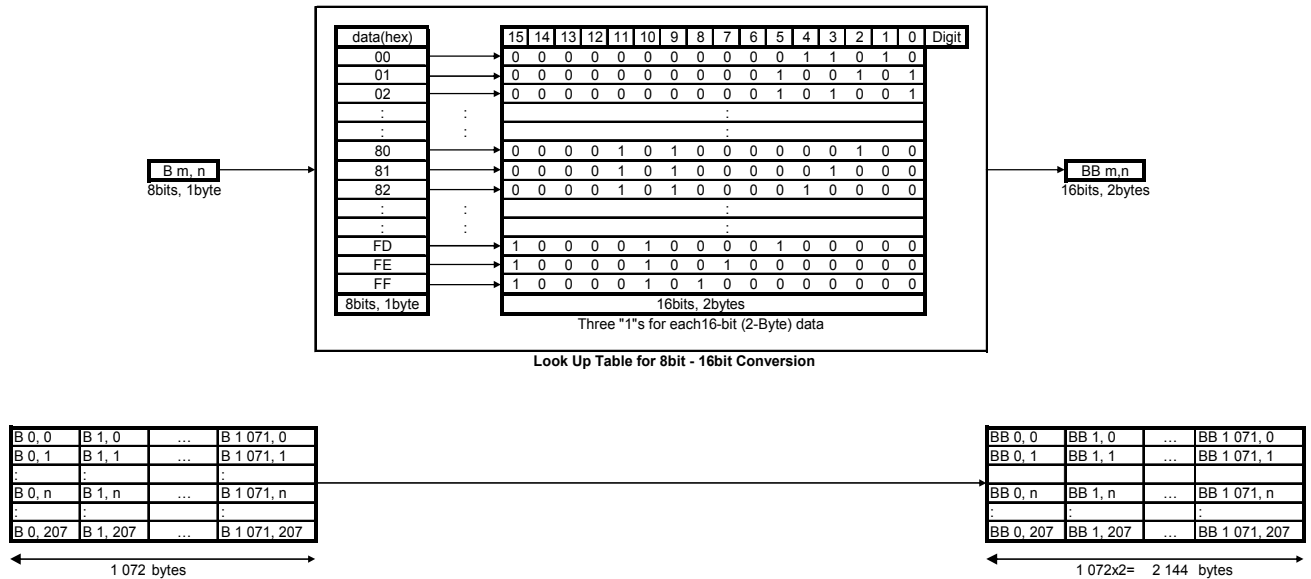

Figure I.2 – 8 to 16 bits conversion

These 2 144 bytes packets shall be then processed by the ECC/LDPC encoding of Figure I.3a, I.3b and I.3c to generate 560 Intra-Page ECC bytes added to each of the initial 1 072 bytes packets.

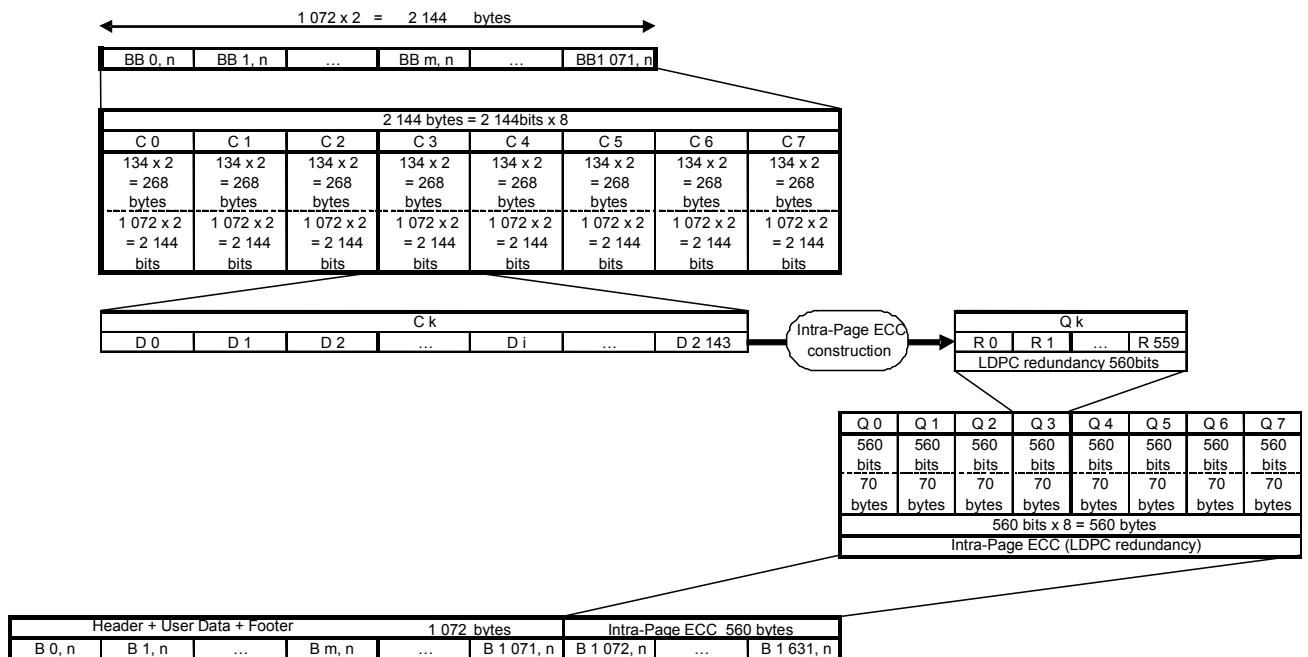

Figure I.3a – Generation of the Intra-Page ECC bytes

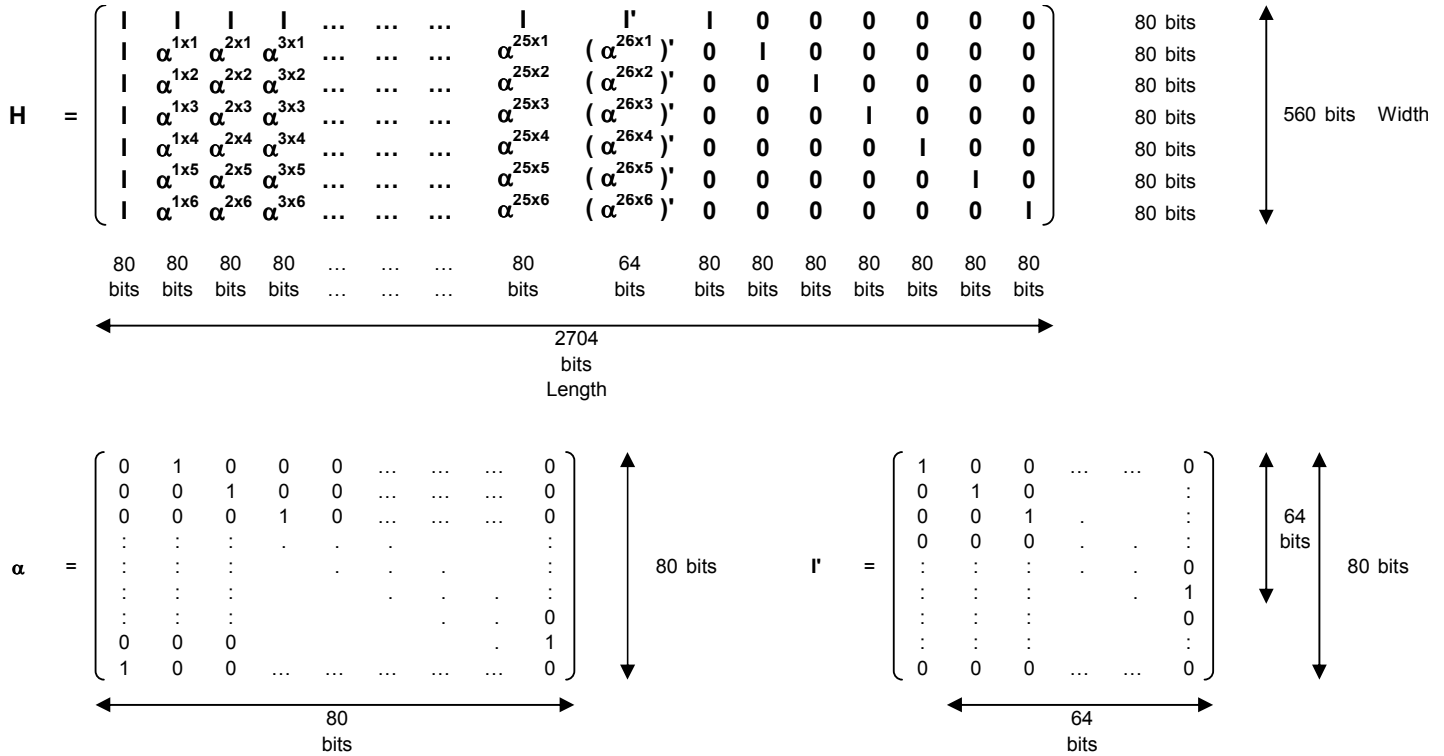

Figure I.3b – Intra-Page ECC code structure

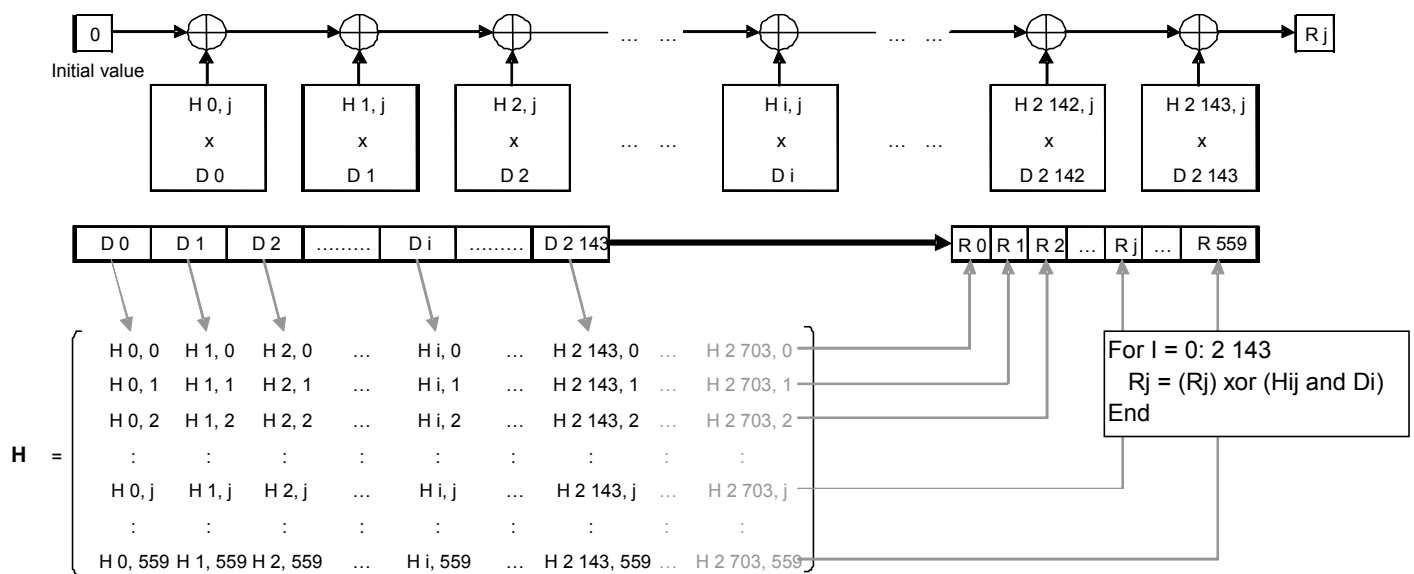

Figure I.3c – Intra-Page ECC code structure





## **Annex J** **(normative)**

### **16 bits to Symbols conversion look-up table**

The conversion of the 16-bits data in Symbols shall be done as shown in Table J.1.

Bits to One shall correspond to ON (illuminated) pixels.

Bits to Zero shall correspond to Off (non-illuminated) pixels.

Table J.1 – 16-bits data to Symbols conversion



















symbol	code				data											
	(binary)				(dec)	(hex)	(dec)									
	0	0	0	0	0	0	0	0	1	1	0	1	0	26	00	0
	0	0	0	0	0	0	0	0	0	0	1	0	1	37	01	1
	0	0	0	0	0	0	0	0	0	0	1	0	1	41	02	2
	0	0	0	0	0	0	0	0	0	1	0	0	1	73	03	3
	0	0	0	0	0	0	0	0	0	1	0	0	1	74	04	4
	0	0	0	0	0	0	0	0	0	1	0	1	0	82	05	5
	0	0	0	0	0	0	0	0	0	1	0	1	0	88	06	6
	0	0	0	0	0	0	0	0	1	0	0	0	1	133	07	7
	0	0	0	0	0	0	0	0	1	0	0	1	0	146	08	8
	0	0	0	0	0	0	0	0	1	0	0	1	0	148	09	9
	0	0	0	0	0	0	0	0	1	0	1	0	0	161	0A	10
	0	0	0	0	0	0	0	0	1	0	1	0	0	164	0B	11
	0	0	0	0	0	0	0	1	0	0	0	0	1	261	0C	12
	0	0	0	0	0	0	0	1	0	0	0	0	1	265	0D	13
	0	0	0	0	0	0	0	1	0	0	0	0	1	266	0E	14
	0	0	0	0	0	0	0	1	0	0	1	0	0	289	0F	15
	0	0	0	0	0	0	0	1	0	0	1	0	0	292	10	16
	0	0	0	0	0	0	0	1	0	0	1	0	0	296	11	17

Table J.1 – 16-bits data to Symbols conversion

	0 0 0 0	0 0 0 1	0 1 0 0	0 0 0 1	321	12	18
	0 0 0 0	0 0 0 1	0 1 0 0	0 0 1 0	322	13	19
	0 0 0 0	0 0 0 1	0 1 0 0	1 0 0 0	328	14	20
	0 0 0 0	0 0 0 1	1 0 0 0	0 0 0 1	385	15	21
	0 0 0 0	0 0 0 1	1 0 0 0	0 0 1 0	386	16	22
	0 0 0 0	0 0 0 1	1 0 0 0	0 1 0 0	388	17	23
	0 0 0 0	0 0 0 1	1 0 0 1	0 0 0 0	416	18	24
	0 0 0 0	0 0 0 1	0 0 0 0	0 1 0 1	517	19	25
	0 0 0 0	0 0 0 1	0 0 0 0	1 0 0 1	521	1A	26
	0 0 0 0	0 0 0 1	0 0 0 0	1 0 1 0	522	1B	27
	0 0 0 0	0 0 0 1	0 0 0 1	0 0 1 0	530	1C	28
	0 0 0 0	0 0 0 1	0 0 0 1	0 1 0 0	532	1D	29
	0 0 0 0	0 0 0 1	0 0 0 1	1 0 0 0	536	1E	30
	0 0 0 0	0 0 0 1	0 1 0 0	0 0 0 1	577	1F	31
	0 0 0 0	0 0 0 1	0 1 0 0	0 0 1 0	578	20	32
	0 0 0 0	0 0 0 1	0 1 0 0	1 0 0 0	584	21	33
	0 0 0 0	0 0 0 1	0 1 0 1	0 0 0 0	592	22	34
	0 0 0 0	0 0 0 1	1 0 0 0	0 0 0 1	641	23	35
	0 0 0 0	0 0 0 1	1 0 0 0	0 0 1 0	642	24	36

Table J.1 – 16-bits data to Symbols conversion

	0 0 0 0	0 0 1 0	1 0 0 0	0 1 0 0	644	25	37
	0 0 0 0	0 0 1 0	1 0 0 1	0 0 0 0	656	26	38
	0 0 0 0	0 1 0 0	0 0 0 0	0 1 0 1	1029	27	39
	0 0 0 0	0 1 0 0	0 0 0 0	1 0 0 1	1033	28	40
	0 0 0 0	0 1 0 0	0 0 0 0	1 0 1 0	1034	29	41
	0 0 0 0	0 1 0 0	0 0 0 1	0 0 1 0	1042	2A	42
	0 0 0 0	0 1 0 0	0 0 0 1	0 1 0 0	1044	2B	43
	0 0 0 0	0 1 0 0	0 0 0 1	1 0 0 0	1048	2C	44
	0 0 0 0	0 1 0 0	0 0 1 0	0 0 0 1	1057	2D	45
	0 0 0 0	0 1 0 0	0 0 1 0	0 1 0 0	1060	2E	46
	0 0 0 0	0 1 0 0	0 0 1 0	1 0 0 0	1064	2F	47
	0 0 0 0	0 1 0 0	1 0 0 0	0 0 0 1	1153	30	48
	0 0 0 0	0 1 0 0	1 0 0 0	0 0 1 0	1154	31	49
	0 0 0 0	0 1 0 0	1 0 0 0	0 1 0 0	1156	32	50
	0 0 0 0	0 1 0 0	1 0 0 1	0 0 0 0	1168	33	51
	0 0 0 0	0 1 0 0	1 0 1 0	0 0 0 0	1184	34	52
	0 0 0 0	0 1 0 1	0 0 0 0	0 0 0 1	1281	35	53
	0 0 0 0	0 1 0 1	0 0 0 0	0 0 1 0	1282	36	54
	0 0 0 0	0 1 0 1	0 0 0 0	0 1 0 0	1284	37	55

Table J.1 – 16-bits data to Symbols conversion

	0 0 0 0	0 1 0 1	0 0 0 0	1 0 0 0	1288	38	56
	0 0 0 0	0 1 0 1	0 0 1 0	0 0 0 0	1312	39	57
	0 0 0 0	0 1 0 1	1 0 0 0	0 0 0 0	1408	3A	58
	0 0 0 0	1 0 0 0	0 0 0 0	0 1 0 1	2053	3B	59
	0 0 0 0	1 0 0 0	0 0 0 0	1 0 0 1	2057	3C	60
	0 0 0 0	1 0 0 0	0 0 0 0	1 0 1 0	2058	3D	61
	0 0 0 0	1 0 0 0	0 0 0 1	0 0 1 0	2066	3E	62
	0 0 0 0	1 0 0 0	0 0 0 1	0 1 0 0	2068	3F	63
	0 0 0 0	1 0 0 0	0 0 0 1	1 0 0 0	2072	40	64
	0 0 0 0	1 0 0 0	0 0 1 0	0 0 0 1	2081	41	65
	0 0 0 0	1 0 0 0	0 0 1 0	0 1 0 0	2084	42	66
	0 0 0 0	1 0 0 0	0 0 1 0	1 0 0 0	2088	43	67
	0 0 0 0	1 0 0 0	0 1 0 0	0 0 0 1	2113	44	68
	0 0 0 0	1 0 0 0	0 1 0 0	0 0 1 0	2114	45	69
	0 0 0 0	1 0 0 0	0 1 0 0	1 0 0 0	2120	46	70
	0 0 0 0	1 0 0 0	0 1 1 0	0 0 0 0	2128	47	71
	0 0 0 0	1 0 0 0	0 0 0 0	0 0 0 1	2305	48	72
	0 0 0 0	1 0 0 0	0 0 0 0	0 0 1 0	2306	49	73
	0 0 0 0	1 0 0 0	0 0 0 0	0 1 0 0	2308	4A	74

Table J.1 – 16-bits data to Symbols conversion

	0 0 0 0	1 0 0 1	0 0 0 0	1 0 0 0	2312	4B	75
	0 0 0 0	1 0 0 1	0 0 1 0	0 0 0 0	2336	4C	76
	0 0 0 0	1 0 0 1	0 1 0 0	0 0 0 0	2368	4D	77
	0 0 0 0	1 0 1 0	0 0 0 0	0 0 0 1	2561	4E	78
	0 0 0 0	1 0 1 0	0 0 0 0	0 0 1 0	2562	4F	79
	0 0 0 0	1 0 1 0	0 0 0 0	0 1 0 0	2564	50	80
	0 0 0 0	1 0 1 0	0 0 0 0	1 0 0 0	2568	51	81
	0 0 0 0	1 0 1 0	0 0 0 1	0 0 0 0	2576	52	82
	0 0 0 0	1 0 1 0	0 1 0 0	0 0 0 0	2624	53	83
	0 0 0 1	0 0 0 0	0 0 0 0	0 1 0 1	4101	54	84
	0 0 0 1	0 0 0 0	0 0 0 0	1 0 0 1	4105	55	85
	0 0 0 1	0 0 0 0	0 0 0 0	1 0 1 0	4106	56	86
	0 0 0 1	0 0 0 0	0 0 0 1	0 0 1 0	4114	57	87
	0 0 0 1	0 0 0 0	0 0 0 1	0 1 0 0	4116	58	88
	0 0 0 1	0 0 0 0	0 0 0 1	1 0 0 0	4120	59	89
	0 0 0 1	0 0 0 0	0 0 1 0	0 0 0 1	4129	5A	90
	0 0 0 1	0 0 0 0	0 0 1 0	0 1 0 0	4132	5B	91
	0 0 0 1	0 0 0 0	0 0 1 0	1 0 0 0	4136	5C	92
	0 0 0 1	0 0 0 0	0 1 0 0	0 0 0 1	4161	5D	93

Table J.1 – 16-bits data to Symbols conversion



















	0 0 0 1	0 0 0 0	0 1 0 0	0 0 1 0	4162	5E	94
	0 0 0 1	0 0 0 0	0 1 0 0	1 0 0 0	4168	5F	95
	0 0 0 1	0 0 0 0	0 1 0 1	0 0 0 0	4176	60	96
	0 0 0 1	0 0 0 0	1 0 0 0	0 0 0 1	4225	61	97
	0 0 0 1	0 0 0 0	1 0 0 0	0 0 1 0	4226	62	98
	0 0 0 1	0 0 0 0	1 0 0 0	0 1 0 0	4228	63	99
	0 0 0 1	0 0 0 0	1 0 0 1	0 0 0 0	4240	64	100
	0 0 0 1	0 0 0 0	1 0 1 0	0 0 0 0	4256	65	101
	0 0 0 1	0 0 1 0	0 0 0 0	0 0 0 1	4609	66	102
	0 0 0 1	0 0 1 0	0 0 0 0	0 0 1 0	4610	67	103
	0 0 0 1	0 0 1 0	0 0 0 0	0 1 0 0	4612	68	104
	0 0 0 1	0 0 1 0	0 0 0 0	1 0 0 0	4616	69	105
	0 0 0 1	0 0 1 0	0 0 0 1	0 0 0 0	4624	6A	106
	0 0 0 1	0 0 1 0	0 1 0 0	0 0 0 0	4672	6B	107
	0 0 0 1	0 0 1 0	1 0 0 0	0 0 0 0	4736	6C	108
	0 0 0 1	0 1 0 0	0 0 0 0	0 0 0 1	5121	6D	109
	0 0 0 1	0 1 0 0	0 0 0 0	0 0 1 0	5122	6E	110
	0 0 0 1	0 1 0 0	0 0 0 0	0 1 0 0	5124	6F	111
	0 0 0 1	0 1 0 0	0 0 0 0	1 0 0 0	5128	70	112

Table J.1 – 16-bits data to Symbols conversion



















	0 0 0 1	0 1 0 0	0 0 0 1	0 0 0 0	5136	71	113
	0 0 0 1	0 1 0 0	0 0 1 0	0 0 0 0	5152	72	114
	0 0 0 1	0 1 0 0	1 0 0 0	0 0 0 0	5248	73	115
	0 0 0 1	1 0 0 0	0 0 0 0	0 0 0 1	6145	74	116
	0 0 0 1	1 0 0 0	0 0 0 0	0 0 1 0	6146	75	117
	0 0 0 1	1 0 0 0	0 0 0 0	0 1 0 0	6148	76	118
	0 0 0 1	1 0 0 0	0 0 0 0	1 0 0 0	6152	77	119
	0 0 0 1	1 0 0 0	0 0 0 1	0 0 0 0	6160	78	120
	0 0 0 1	1 0 0 0	0 0 1 0	0 0 0 0	6176	79	121
	0 0 0 1	1 0 0 0	0 1 0 0	0 0 0 0	6208	7A	122
	0 0 0 1	1 0 1 0	0 0 0 0	0 0 0 0	6656	7B	123
	0 0 1 0	0 0 0 0	0 0 0 0	0 1 0 1	8197	7C	124
	0 0 1 0	0 0 0 0	0 0 0 0	1 0 0 1	8201	7D	125
	0 0 1 0	0 0 0 0	0 0 0 0	1 0 1 0	8202	7E	126
	0 0 1 0	0 0 0 0	0 0 0 1	0 0 1 0	8210	7F	127
	0 0 1 0	0 0 0 0	0 0 0 1	0 1 0 0	8212	80	128
	0 0 1 0	0 0 0 0	0 0 0 1	1 0 0 0	8216	81	129
	0 0 1 0	0 0 0 0	0 0 1 0	0 0 0 1	8225	82	130
	0 0 1 0	0 0 0 0	0 0 1 0	0 1 0 0	8228	83	131



Table J.1 – 16-bits data to Symbols conversion



















	0 0 1 0	0 0 0 0	0 0 1 0	1 0 0 0	8232	84	132
	0 0 1 0	0 0 0 0	0 1 0 0	0 0 0 1	8257	85	133
	0 0 1 0	0 0 0 0	0 1 0 0	0 0 1 0	8258	86	134
	0 0 1 0	0 0 0 0	0 1 0 0	1 0 0 0	8264	87	135
	0 0 1 0	0 0 0 0	0 1 0 1	0 0 0 0	8272	88	136
	0 0 1 0	0 0 0 0	1 0 0 0	0 0 0 1	8321	89	137
	0 0 1 0	0 0 0 0	1 0 0 0	0 0 1 0	8322	8A	138
	0 0 1 0	0 0 0 0	1 0 0 0	0 1 0 0	8324	8B	139
	0 0 1 0	0 0 0 0	1 0 0 1	0 0 0 0	8336	8C	140
	0 0 1 0	0 0 0 0	1 0 1 0	0 0 0 0	8352	8D	141
	0 0 1 0	0 0 0 1	0 0 0 0	0 0 0 1	8449	8E	142
	0 0 1 0	0 0 0 1	0 0 0 0	0 0 1 0	8450	8F	143
	0 0 1 0	0 0 0 1	0 0 0 0	0 1 0 0	8452	90	144
	0 0 1 0	0 0 0 1	0 0 0 0	1 0 0 0	8456	91	145
	0 0 1 0	0 0 0 1	0 0 1 0	0 0 0 0	8480	92	146
	0 0 1 0	0 0 0 1	0 1 0 0	0 0 0 0	8512	93	147
	0 0 1 0	0 0 0 1	1 0 0 0	0 0 0 0	8576	94	148
	0 0 1 0	0 1 0 0	0 0 0 0	0 0 0 1	9217	95	149
	0 0 1 0	0 1 0 0	0 0 0 0	0 0 1 0	9218	96	150

Table J.1 – 16-bits data to Symbols conversion



















	0 0 1 0	0 1 0 0	0 0 0 0	0 1 0 0	9220	97	151
	0 0 1 0	0 1 0 0	0 0 0 0	1 0 0 0	9224	98	152
	0 0 1 0	0 1 0 0	0 0 0 1	0 0 0 0	9232	99	153
	0 0 1 0	0 1 0 0	0 0 1 0	0 0 0 0	9248	9A	154
	0 0 1 0	0 1 0 0	1 0 0 0	0 0 0 0	9344	9B	155
	0 0 1 0	0 1 0 1	0 0 0 0	0 0 0 0	9472	9C	156
	0 0 1 0	1 0 0 0	0 0 0 0	0 0 0 1	10241	9D	157
	0 0 1 0	1 0 0 0	0 0 0 0	0 0 1 0	10242	9E	158
	0 0 1 0	1 0 0 0	0 0 0 0	0 1 0 0	10244	9F	159
	0 0 1 0	1 0 0 0	0 0 0 0	1 0 0 0	10248	A0	160
	0 0 1 0	1 0 0 0	0 0 0 1	0 0 0 0	10256	A1	161
	0 0 1 0	1 0 0 0	0 0 1 0	0 0 0 0	10272	A2	162
	0 0 1 0	1 0 0 0	0 1 0 0	0 0 0 0	10304	A3	163
	0 0 1 0	1 0 0 1	0 0 0 0	0 0 0 0	10496	A4	164
	0 1 0 0	0 0 0 0	0 0 0 0	0 1 0 1	16389	A5	165
	0 1 0 0	0 0 0 0	0 0 0 0	1 0 0 1	16393	A6	166
	0 1 0 0	0 0 0 0	0 0 0 0	1 0 1 0	16394	A7	167
	0 1 0 0	0 0 0 0	0 0 0 1	0 0 1 0	16402	A8	168
	0 1 0 0	0 0 0 0	0 0 0 1	0 1 0 0	16404	A9	169

Table J.1 – 16-bits data to Symbols conversion



















	0 1 0 0	0 0 0 0	0 0 0 1	1 0 0 0	16408	AA	170
	0 1 0 0	0 0 0 0	0 0 1 0	0 0 0 1	16417	AB	171
	0 1 0 0	0 0 0 0	0 0 1 0	0 1 0 0	16420	AC	172
	0 1 0 0	0 0 0 0	0 0 1 0	1 0 0 0	16424	AD	173
	0 1 0 0	0 0 0 0	0 1 0 0	0 0 0 1	16449	AE	174
	0 1 0 0	0 0 0 0	0 1 0 0	0 0 1 0	16450	AF	175
	0 1 0 0	0 0 0 0	0 1 0 0	1 0 0 0	16456	B0	176
	0 1 0 0	0 0 0 0	0 1 0 1	0 0 0 0	16464	B1	177
	0 1 0 0	0 0 0 0	1 0 0 0	0 0 0 1	16513	B2	178
	0 1 0 0	0 0 0 0	1 0 0 0	0 0 1 0	16514	B3	179
	0 1 0 0	0 0 0 0	1 0 0 0	0 1 0 0	16516	B4	180
	0 1 0 0	0 0 0 0	1 0 0 1	0 0 0 0	16528	B5	181
	0 1 0 0	0 0 0 0	1 0 1 0	0 0 0 0	16544	B6	182
	0 1 0 0	0 0 0 1	0 0 0 0	0 0 0 1	16641	B7	183
	0 1 0 0	0 0 0 1	0 0 0 0	0 0 1 0	16642	B8	184
	0 1 0 0	0 0 0 1	0 0 0 0	0 1 0 0	16644	B9	185
	0 1 0 0	0 0 0 1	0 0 0 0	1 0 0 0	16648	BA	186
	0 1 0 0	0 0 0 1	0 0 1 0	0 0 0 0	16672	BB	187
	0 1 0 0	0 0 0 1	0 1 0 0	0 0 0 0	16704	BC	188

Table J.1 – 16-bits data to Symbols conversion



















	0 1 0 0	0 0 0 1	1 0 0 0	0 0 0 0	16768	BD	189
	0 1 0 0	0 0 1 0	0 0 0 0	0 0 0 1	16897	BE	190
	0 1 0 0	0 0 1 0	0 0 0 0	0 0 1 0	16898	BF	191
	0 1 0 0	0 0 1 0	0 0 0 0	0 1 0 0	16900	C0	192
	0 1 0 0	0 0 1 0	0 0 0 0	1 0 0 0	16904	C1	193
	0 1 0 0	0 0 1 0	0 0 0 1	0 0 0 0	16912	C2	194
	0 1 0 0	0 0 1 0	0 1 0 0	0 0 0 0	16960	C3	195
	0 1 0 0	0 0 1 0	1 0 0 0	0 0 0 0	17024	C4	196
	0 1 0 0	1 0 0 0	0 0 0 0	0 0 0 1	18433	C5	197
	0 1 0 0	1 0 0 0	0 0 0 0	0 0 1 0	18434	C6	198
	0 1 0 0	1 0 0 0	0 0 0 0	0 1 0 0	18436	C7	199
	0 1 0 0	1 0 0 0	0 0 0 0	1 0 0 0	18440	C8	200
	0 1 0 0	1 0 0 0	0 0 0 1	0 0 0 0	18448	C9	201
	0 1 0 0	1 0 0 0	0 0 1 0	0 0 0 0	18464	CA	202
	0 1 0 0	1 0 0 0	0 1 0 0	0 0 0 0	18496	CB	203
	0 1 0 0	1 0 0 1	0 0 0 0	0 0 0 0	18688	CC	204
	0 1 0 0	1 0 1 0	0 0 0 0	0 0 0 0	18944	CD	205
	0 1 0 1	0 0 0 0	0 0 0 0	0 0 0 1	20481	CE	206
	0 1 0 1	0 0 0 0	0 0 0 0	0 0 1 0	20482	CF	207

Table J.1 – 16-bits data to Symbols conversion



















	0 1 0 1	0 0 0 0	0 0 0 0	0 1 0 0	20484	D0	208
	0 1 0 1	0 0 0 0	0 0 0 0	1 0 0 0	20488	D1	209
	0 1 0 1	0 0 0 0	0 0 0 1	0 0 0 0	20496	D2	210
	0 1 0 1	0 0 0 0	0 0 1 0	0 0 0 0	20512	D3	211
	0 1 0 1	0 0 0 0	0 1 0 0	0 0 0 0	20544	D4	212
	0 1 0 1	0 0 0 0	1 0 0 0	0 0 0 0	20608	D5	213
	0 1 0 1	0 0 1 0	0 0 0 0	0 0 0 0	20992	D6	214
	0 1 0 1	1 0 0 0	0 0 0 0	0 0 0 0	22528	D7	215
	1 0 0 0	0 0 0 0	0 0 0 0	0 1 0 1	32773	D8	216
	1 0 0 0	0 0 0 0	0 0 0 0	1 0 0 1	32777	D9	217
	1 0 0 0	0 0 0 0	0 0 0 0	1 0 1 0	32778	DA	218
	1 0 0 0	0 0 0 0	0 0 0 1	0 0 1 0	32786	DB	219
	1 0 0 0	0 0 0 0	0 0 0 1	0 1 0 0	32788	DC	220
	1 0 0 0	0 0 0 0	0 0 0 1	1 0 0 0	32792	DD	221
	1 0 0 0	0 0 0 0	0 0 1 0	0 0 0 1	32801	DE	222
	1 0 0 0	0 0 0 0	0 0 1 0	0 1 0 0	32804	DF	223
	1 0 0 0	0 0 0 0	0 0 1 0	1 0 0 0	32808	E0	224
	1 0 0 0	0 0 0 0	0 1 0 0	0 0 0 1	32833	E1	225
	1 0 0 0	0 0 0 0	0 1 0 0	0 0 1 0	32834	E2	226

Table J.1 – 16-bits data to Symbols conversion





























	1 0 0 0	0 0 0 0	0 1 0 0	1 0 0 0	32840	E3	227
	1 0 0 0	0 0 0 0	0 1 0 1	0 0 0 0	32848	E4	228
	1 0 0 0	0 0 0 0	1 0 0 0	0 0 0 1	32897	E5	229
	1 0 0 0	0 0 0 0	1 0 0 0	0 0 1 0	32898	E6	230
	1 0 0 0	0 0 0 0	1 0 0 0	0 1 0 0	32900	E7	231
	1 0 0 0	0 0 0 0	1 0 0 1	0 0 0 0	32912	E8	232
	1 0 0 0	0 0 0 0	1 0 1 0	0 0 0 0	32928	E9	233
	1 0 0 0	0 0 0 1	0 0 0 0	0 0 0 1	33025	EA	234
	1 0 0 0	0 0 0 1	0 0 0 0	0 0 1 0	33026	EB	235
	1 0 0 0	0 0 0 1	0 0 0 0	0 1 0 0	33028	EC	236
	1 0 0 0	0 0 0 1	0 0 0 0	1 0 0 0	33032	ED	237
	1 0 0 0	0 0 0 1	0 0 1 0	0 0 0 0	33056	EE	238
	1 0 0 0	0 0 0 1	0 1 0 0	0 0 0 0	33088	EF	239
	1 0 0 0	0 0 0 1	1 0 0 0	0 0 0 0	33152	F0	240
	1 0 0 0	0 0 1 0	0 0 0 0	0 0 0 1	33281	F1	241
	1 0 0 0	0 0 1 0	0 0 0 0	0 0 1 0	33282	F2	242
	1 0 0 0	0 0 1 0	0 0 0 0	0 1 0 0	33284	F3	243
	1 0 0 0	0 0 1 0	0 0 0 0	1 0 0 0	33288	F4	244
	1 0 0 0	0 0 1 0	0 0 0 1	0 0 0 0	33296	F5	245

Table J.1 – 16-bits data to Symbols conversion

	1 0 0 0	0 0 1 0	0 1 0 0	0 0 0 0	33344	F6	246
	1 0 0 0	0 0 1 0	1 0 0 0	0 0 0 0	33408	F7	247
	1 0 0 0	0 1 0 0	0 0 0 0	0 0 0 1	33793	F8	248
	1 0 0 0	0 1 0 0	0 0 0 0	0 0 1 0	33794	F9	249
	1 0 0 0	0 1 0 0	0 0 0 0	0 1 0 0	33796	FA	250
	1 0 0 0	0 1 0 0	0 0 0 0	1 0 0 0	33800	FB	251
	1 0 0 0	0 1 0 0	0 0 0 1	0 0 0 0	33808	FC	252
	1 0 0 0	0 1 0 0	0 0 1 0	0 0 0 0	33824	FD	253
	1 0 0 0	0 1 0 0	1 0 0 0	0 0 0 0	33920	FE	254
	1 0 0 0	0 1 0 1	0 0 0 0	0 0 0 0	34048	FF	255





## Annex K (normative)

### Finalizing data

The Finalizing data recorded in the Lead-out Zone shall be as shown in Table K.1.

The 41 finalizing bytes shall be recorded at the beginning of a Data Page filled with additional bytes containing Zero data.

Table K.1 – Finalizing data

Item	Format/ Meaning	Bytes
Version of disk format	1 / HVD-R 200 GB	2
Version of Specific Disk Information	n / Version number x 100	2
Disk category	1 / HVD-R, 2 / HVD-ROM	2
Disk size	1 / 120 mm	2
Disk capacity	n / n Gbytes	2
Reserved	Set to Zero	10
Energy density for permanent fixing	n / n Joules.cm <sup>-2</sup>	2
Reserved	Set to Zero	2
Hologram read energy	n / n nanoJoules	2
Write strategy	1 / Sequential	1
Hologram maximum write energy	n / n nanoJoules	2
Start track of user data	n / Track address number	2
Start Sector of user data	n / Sector address number	1
Start Channel bit of user data	n / Channel bit number	2
End track of user data	n / Track address number	2
End Sector of user data	n / Sector address number	1
End Channel bit of user data	n / Channel bit number	2
Amount of stored data	n / n Gbytes	2



## Annex L (normative)

### Tracking/Addressing and Data Reading Channels characteristics

#### L.1 Tracking/Addressing Channel characteristics

Analog signals and jitter shall be measured in the Tracking/Addressing Channel using the following circuit:

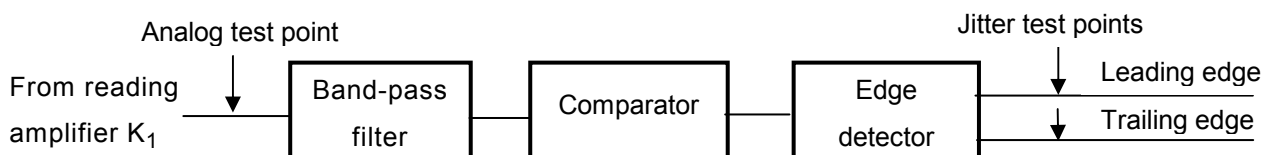
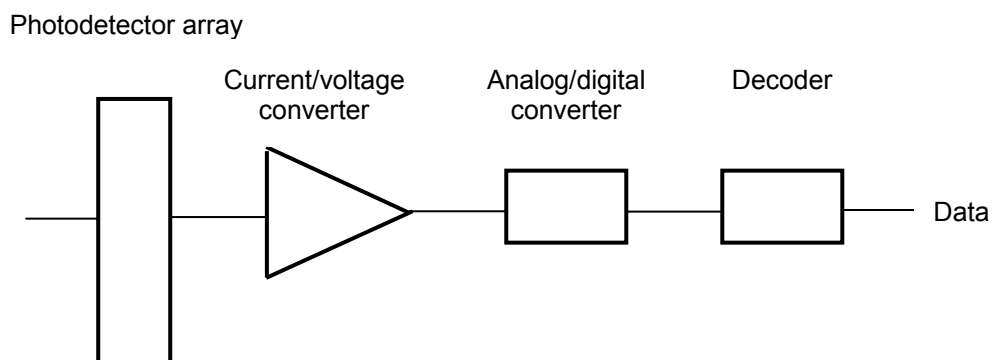

*Figure L.1 – Addressing Channel block diagram*

The band-pass filter shall be of the 2<sup>nd</sup> Order Bessel type with a bandwidth frequency of 20 Hz to 2 MHz.

#### L.2 Data Reading Channel characteristics

Data shall be detected in the Data Reading Channel by the following circuit:

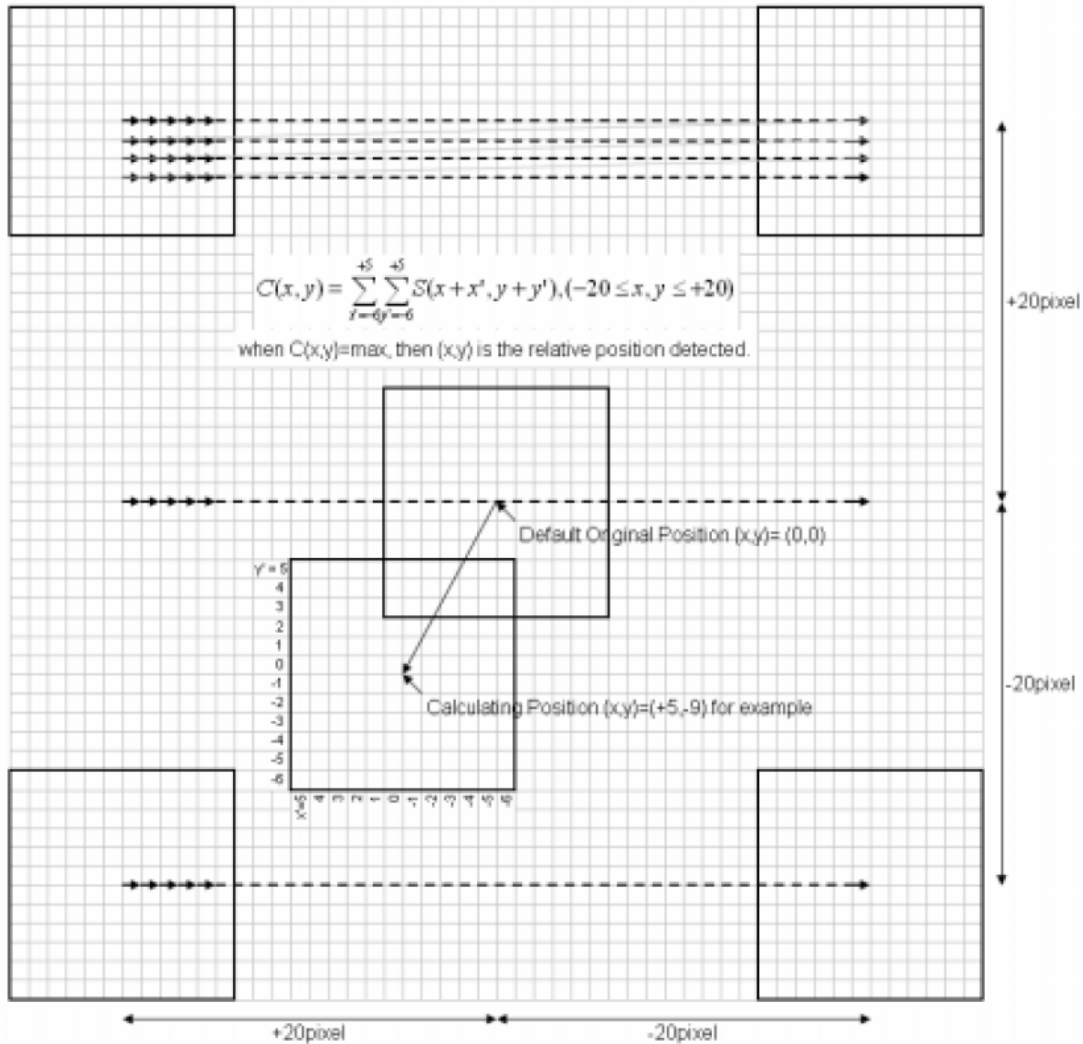

*Figure L.2 – Data Reading Channel block diagram*

### L.2.1 Sync Marks detection

The Data Page Sync Mark shall be detected, as shown on Figure K.3a, by calculating the sum of the intensity of 12x12 (-6 to +6) pixels square for different positions of centre of this square in a range of 40x40 (-20 to +20) pixels around its supposed nominal position.

The position of the Data Page Sync Mark corresponds to the maximum of the detected sum.



$S(x+x', y+y')$  is the pixel signal intensity on the photodetector array.

Figure L.3a – Example of detection process of the Data Page Sync Mark

The Sub-Page Sync Mark shall be detected, as shown on Figure L.3b, by calculating the sum of the intensity of 12x12 (-6 to +6) pixels square for different positions of centre of this square in a range of 40x40 (-20 to +20) pixels around its supposed nominal position

The position of the Sync Mark corresponds to the maximum of the detected sum.

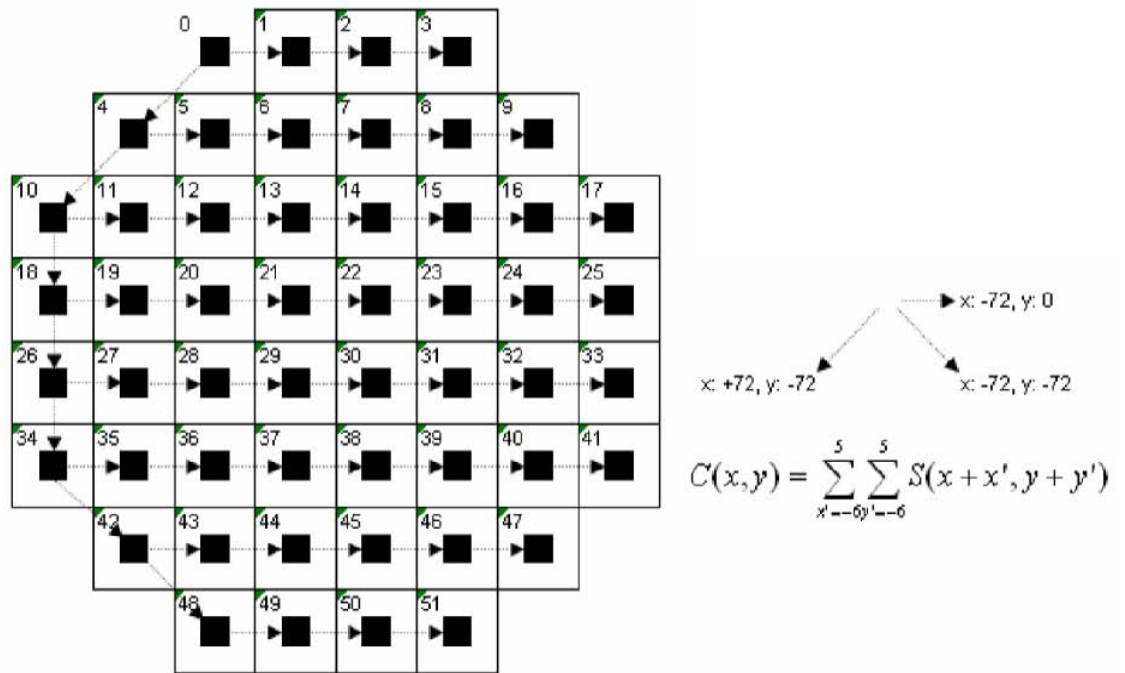

Figure L.3b – Example of detection process of the Sub-Page Sync Mark

## L.2.2 Symbol decoding

The Symbol decoding shall be performed by a correlation process, as shown on Figure L.4.

The data content of the Symbol shall be the data content of the filter  $F_i(x,y)$  giving the maximum of the multiplication signal  $C_i$ .

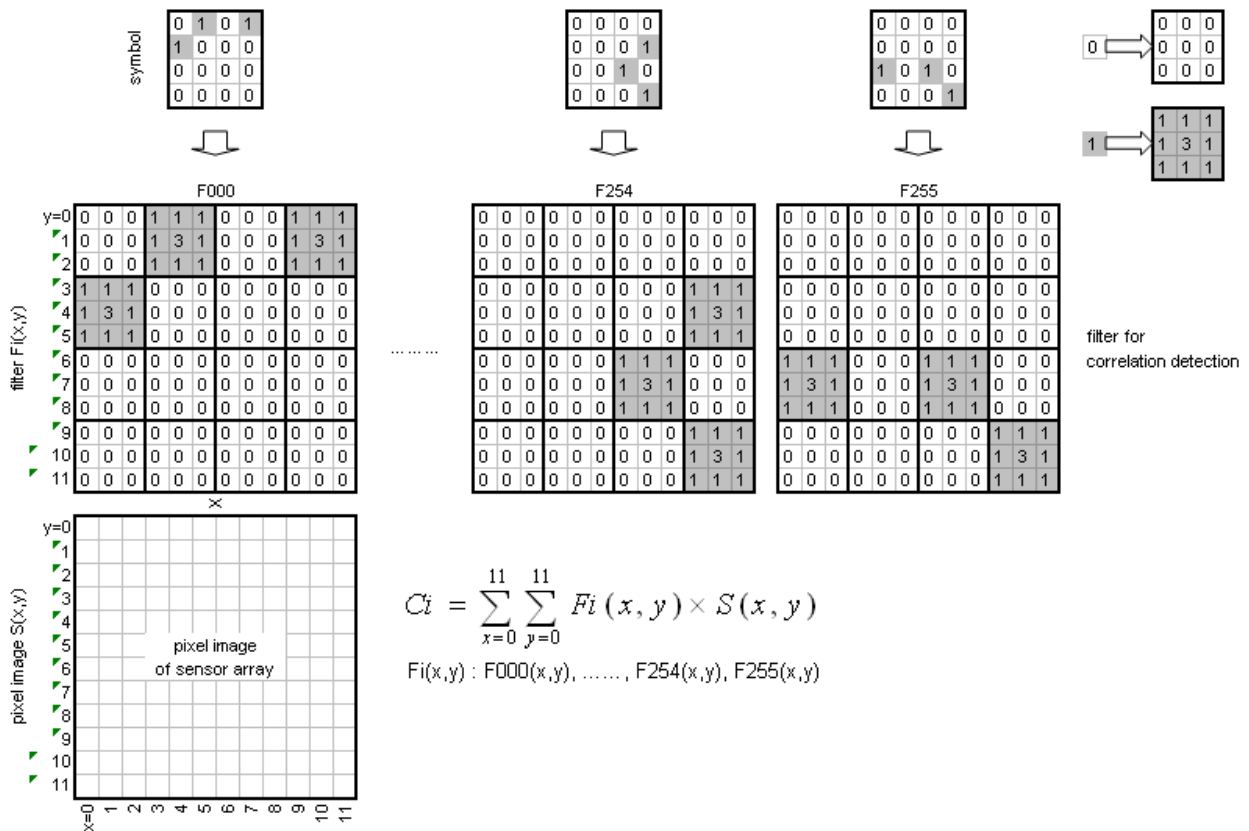
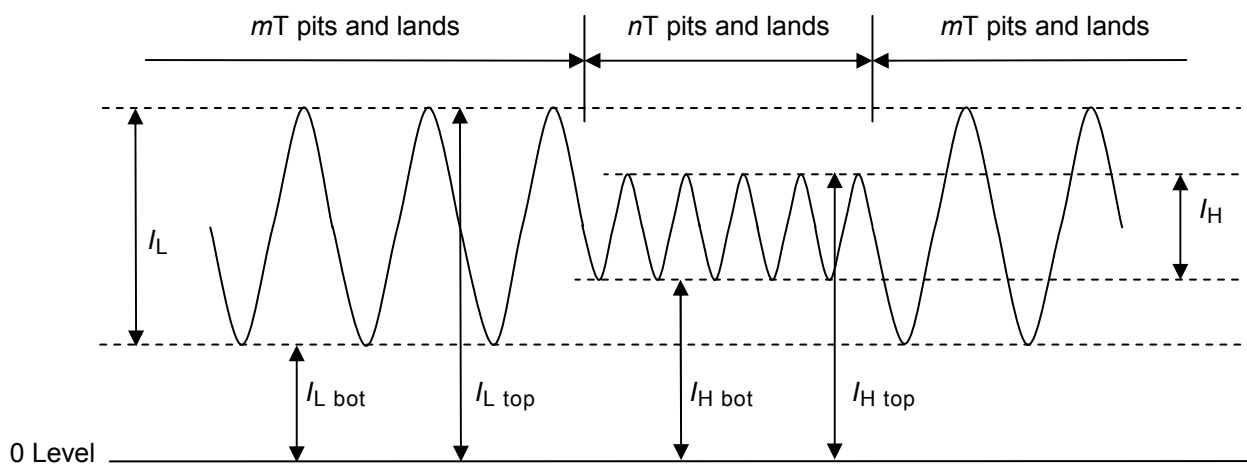

Figure L.4 – Symbol decoding

## Annex M (normative)

### Asymmetry measuring definition

The asymmetry of signals from  $mT$  and  $nT$  pits and lands shall be measured based on the following definitions. See Figure L.1.



*Figure M.1 – Signal from tracking/addressing data with  $mT$  and  $nT$  pits and lands*

$$\text{Asymmetry } (mT-nT) = \frac{1/2 [(I_{L \text{ top}} + I_{L \text{ bot}}) - (I_{H \text{ top}} + I_{H \text{ bot}})]}{I_{L \text{ top}} - I_{L \text{ bot}}}$$

where

$I_L$  and  $I_H$  are the peak-to-peak values of the Tracking/Addressing Channel signals for  $mT$  and  $nT$  pits and lands, read under the conditions specified in 20.2.

$I_{L \text{ top}}$ ,  $I_{H \text{ top}}$ ,  $I_{L \text{ bot}}$ ,  $I_{H \text{ bot}}$  are the top and bottom levels of  $I_L$  and  $I_H$ .





## **Annex N** **(informative)**

### **Office environment**

#### **N.1 Air cleanliness**

---

Due to their construction and mode of operation, Holographic Disk Cartridges have considerable resistance to the effects of dust particles around and inside the disk drive. Consequently, it is not generally necessary to take special precautions to maintain a sufficiently low concentration of dust particles.

Operation in heavy concentrations of dust should be avoided, e.g. in a machine shop or on a building site.

Office environment implies an environment in which personnel may spend a full working day without protection and without suffering temporary or permanent discomfort.

#### **N.2 Effects of operation**

---

In the office environment (as well as other environments) it is possible for a holographic disk drive to degrade the quality of the written pixels if the reading energy is applied to a track for a long period of time.

The media manufacturer's selection of the value for the maximum reading energy allowed in the User data Zones, as well as the drive manufacturer's reading energy management method, should reflect this possibility and be designed to minimize any risk to data integrity.



## Annex O (informative)

### Transportation

#### O.1 General

---

As transportation occurs under a wide range of temperature and humidity variations, for different periods, by many methods of transport and in all parts of the world it is not possible to specify conditions for transportation or for packaging.

The following gives recommendations.

#### O.2 Packaging

---

The form of packaging should be agreed between sender and recipient or, in the absence of such agreement, is the responsibility of the sender. It should take account of the following hazards.

##### O.2.1 Temperature and humidity

Insulation and wrapping should be designed to maintain the following conditions during transportation.

###### O.2.1.1 Cartridges before finalizing

Temperature	10°C to 30°C
Atmospheric pressure	60 kPa to 106 kPa
Relative Humidity	5% to 50%
Absolute air humidity	25g/m <sup>3</sup> max.
Ambient light (shutter close)	135 µW/cm <sup>2</sup>
Duration	10 consecutive days max.

No condensation in or on the cartridge.

###### O.2.1.2 Cartridges after finalizing

Temperature	5°C to 32°C
Atmospheric pressure	60 kPa to 106 kPa
Relative Humidity	5% to 80%
Absolute air humidity	25 g/m <sup>3</sup> max.
Ambient light (shutter close)	135 µW/cm <sup>2</sup>

No condensation in or on the cartridge.

##### O.2.2 Impact loads and vibration

Avoid mechanical loads that would distort the shape of the cartridge.

Avoid dropping the cartridge.

Cartridges should be packed in a rigid box containing adequate shock absorbent material.

The final box should have a clean interior and a construction that provides sealing to prevent the ingress of dirt and moisture.



## Annex P (informative)

### Track deviation measurement

The deviation of a track from its nominal location is measured in the same way as a drive sees a track, i.e. through a tracking servo. The strength of the Reference Servo used for the test is in general less than the strength of the same servo in a normal drive. The difference in strength is intended for margins in the drive. The deviation of the track is related to the tracking error between the track and the focus of the optical beam, remaining after the Reference Servo. The tracking error directly influences the performance of the drive, and is the best criterion for testing track deviations.

The specification of the axial and radial deviations can be described in the same terms. Therefore, this annex applies to both axial and radial track deviations.

#### P.1 Relation between requirements

The acceleration required by the motor of the tracking servo to make the focus of the optical beam follow the tracks on the disk (see 11.5.6 and 11.5.8) is a measure for the allowed deviations of the tracks. An additional measure is the allowed tracking error between the focus and the track (see 20.2.4). The relation between both is given in Figure P.1 where the maximum allowed amplitude of a sinusoidal track deviation is given as a function of the frequency of the deviation. It is assumed in the figure that there is only one sinusoidal deviation present at a time.

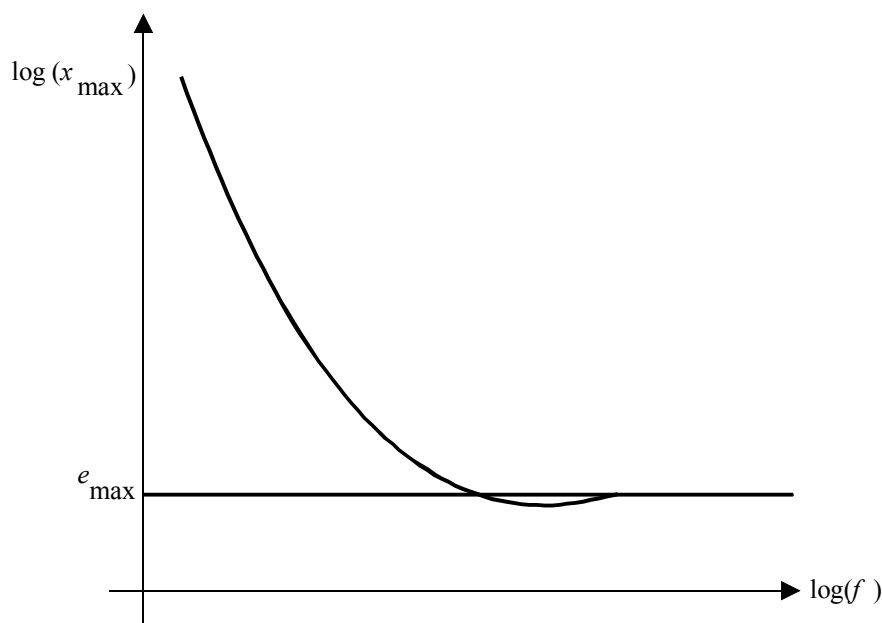

94-0145-A

*Figure P.1 - Maximum allowed amplitude of a single, sinusoidal track deviation*

At low frequencies the maximum allowed amplitude  $x_{\max}$  is given by

$$x_{\max} = a_{\max} / (2\pi f)^2, \quad (1)$$

where  $a_{\max}$  is the maximum acceleration of the servo motor.

At high frequencies the maximum allowed amplitude  $x_{\max}$  is given by

$$x_{\max} = e_{\max} \quad (2)$$

where  $e_{\max}$  is the maximum allowed tracking error. The connection between both frequency regions is given in P.3.

## P.2 Reference Servo

The above restrictions of the track deviations are equal to the restriction of the track deviations for a Reference Servo. A Reference Servo has a well-defined transfer function, and reduces a single, sinusoidal track deviation with amplitude  $x_{\max}$  to a tracking error  $e_{\max}$  as in Figure P.1.

The open-loop transfer function of the Reference Servo shall be

$$H_s(i\omega) = \frac{1}{c} \times \left( \frac{\omega_0}{i\omega} \right)^2 \times \frac{1 + \frac{i\omega c}{\omega_0}}{1 + \frac{i\omega}{c\omega_0}} \quad (3)$$

where  $i = \sqrt{-1}$ ,  $\omega = 2\pi f$  and  $\omega_0 = 2\pi f_0$ , with  $f_0$  the 0 dB frequency of the open-loop transfer function. The constant  $c$  gives the cross-over frequencies of the lead-lag network of the servo:

the lead break frequency  $f_1 = \frac{f_0}{c}$  and the lag break frequency  $f_2 = f_0 \times c$ . The reduction of a track deviation  $x$  to a tracking error  $e$  by the Reference Servo is given by

$$\frac{e}{x} = \frac{1}{1 + H_s} \quad (4)$$

If the 0 dB frequency is specified as

$$\omega_0 = \sqrt{\frac{a_{\max} c}{e_{\max}}} \quad (5)$$

then a low-frequency track deviation with an acceleration  $a_{\max}$  will be reduced to a tracking error  $e_{\max}$ , and a high frequency track deviation will not be reduced. The curve in Figure P.1 is given by

$$x_{\max} = e_{\max} |1 + H_s| \quad (6)$$

The maximum acceleration required from the motor of this Reference Servo is

$$a_{\max} (\text{motor}) = e_{\max} \omega^2 |1 + H_s| \quad (7)$$

At low frequencies  $f > f_0 / c$  applies

$$a_{\max} (\text{motor}) = a_{\max} (\text{track}) = \frac{\omega_0^2 e_{\max}}{c} \quad (8)$$

Hence, it is permitted to use  $a_{\max}(\text{motor})$  as specified for low frequencies in 11.5.6 and 11.5.8 for the calculation of  $\omega_0$  of a Reference Servo.

### P.3 Requirement for track deviations

The track deviations shall be such that, when tracking with a Reference Servo on a disk rotating at the specified frequency, the tracking error shall not be larger than  $e_{\max}$  during more than 10  $\mu\text{s}$ .

The open-loop transfer function of the Reference Servo for axial and radial tracking shall be given by equation (3) within an accuracy such that  $|1 + H|$  does not differ by more than  $\pm 20\%$  from its nominal value in a bandwidth from 20 Hz to 150 kHz. The constant  $c$  shall be 3. The

0 dB frequency  $\frac{\omega_0}{2\pi}$  shall be given by equation (5), where  $a_{\max}$  and  $e_{\max}$  for axial and radial tracking are specified in 11.5.6, 11.5.8 and 20.2.4.

### P.4 Measurement implementation

Three possible implementations for axial or radial measurement systems have been given below.

$H_a$  is the open-loop transfer function of the actual tracking servo of the drive.  $H_s$  is the transfer function for the Reference Servo as given in equation (3).  $x$  and  $y$  are the position of the track and the focus of the optical beam.  $e_s$  is the tracking error after a Reference Servo, the signal of which has to be checked according to the previous paragraph.

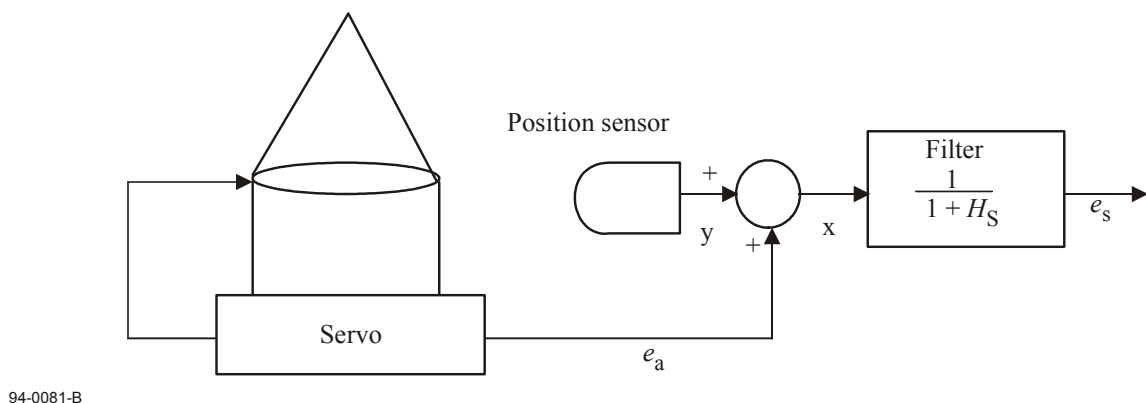

Figure P.2 - Implementation of a Reference Servo by filtering the track position signal with the reduction characteristics of the Reference Servo

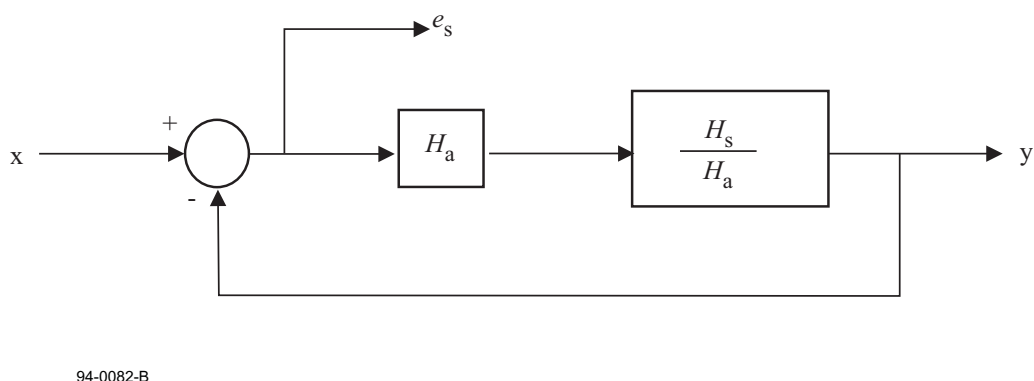
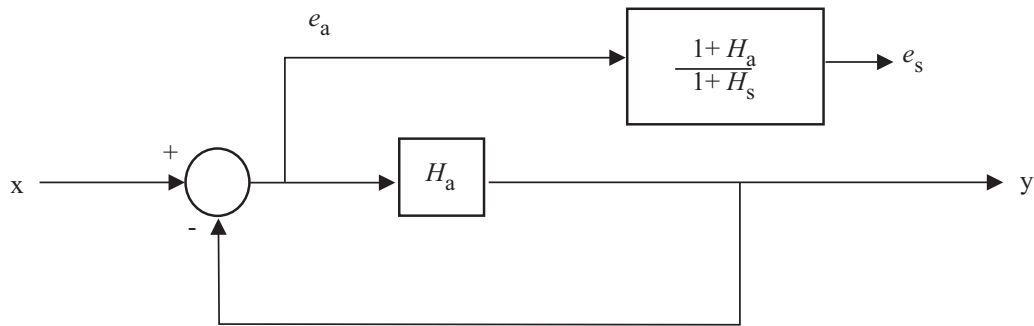

Figure P.3 - Implementation of a Reference Servo by changing the transfer function of the actual servo



94-0083-B

*Figure P.4 - Implementation of a Reference Servo by changing the tracking error of the actual servo*

The optimum implementation depends on the characteristics  $H_a$  and  $H_s$ . Good results for motors in leaf springs are often obtained by using separate circuits in a low and high frequency channel. The implementation of Figure P.2 is used in the low-frequency channel, while that of Figures P.3 or P.4 is used in the high-frequency channel. The signals from both channels are added with a reversed cross-over filter to get the required tracking error. In the low-frequency channel one can also use the current through the motor as a measure of the acceleration of the motor, provided the latter is free from hysteresis. The current must be corrected for the transfer function of the motor and then be converted to a tracking error with a filter with a transfer function  $\frac{e}{a} = \frac{e}{x\omega^2}$  derived from equation (4).





