

Standard ECMA-395

1st Edition / December 2010

**Recordable Compact
Disc Systems CD-RW
Ultra-Speed**

Standard



is the registered trademark of Ecma International



COPYRIGHT PROTECTED DOCUMENT

Ultra-Speed
Compact Disc ReWritable
System Description

August 2010

Table of Contents

Table of Contents i

List of illustrations iv

List of tables v

1. General 1-1

 1.1 Scope 1-1

 1.2 General Description 1-1

 1.3 References and conformance 1-2

 1.4 Definitions 1-3

 1.4.1 General 1-3

 1.4.2 Disc Lay-out 1-6

 1.4.3 Writing modes 1-9

 1.4.4 Signals 1-10

2. Disc Specification 2-1

 2.1 General 2-1

 2.1.1 Standard atmospheric conditions for testing 2-1

 2.1.2 The optical pick-up unit for disc measurements 2-1

 2.1.3 Write strategies for US24 and US32 media testing 2-2

 2.1.3.1 US24 media testing 2-2

 2.1.3.1.1 US24 media testing with '1T' Write-strategy 2-2

 2.1.3.1.2 US24 media testing with '2T' Write-strategy 2-3

 2.1.3.1.3 '2T' Write-strategy parameter range for US24 discs 2-5

 2.1.3.2 US32 media testing 2-5

 2.1.3.2.1 US32 media testing with '1T' Write-strategy 2-5

 2.1.3.2.2 US32 media testing with '2T' Write-strategy 2-5

 2.1.3.2.3 '2T' Write-strategy parameter range for US32 discs 2-7

 2.2 The unrecorded disc 2-7

 2.3 The recorded disc 2-11

 2.4 The recorded disc specifications for read-out at shorter wavelengths (optional) 2-13

3. Requirements & recommendations for CD-recorders 3-1

 3.1 Use of Disc Application Code, RID code and SCMS 3-1

 3.2 Use of Skip features in audio discs 3-1

 3.3 Use of Mode 6 for Disc Identification 3-1

4. Pre-groove modulation, ATIP 4-1

 4.1 General parameters 4-1

 4.2 FM modulation 4-1

 4.3 Frame format 4-1

 4.3.1 Frame synchronization 4-1

 4.4 Data format 4-2

 4.4.1 Special Information 1 : M1,S1,F1 = 101 4-4

 4.4.1.1 Indicative Target Writing Power at 1T Test Speed: W1..W3 4-4

 4.4.1.2 1T Test Speed: V1..V3 4-5

 4.4.1.3 Disc Application Code: U1..U7 4-5

 4.4.1.4 Disc type identification: D1 4-6

 4.4.1.5 Disc sub-type identification: B1..B3 4-6

 4.4.1.6 Additional Information 1, 2 or 3 present: A1..A3 4-6

 4.4.2 Special Information 2 : M1,S1,F1 = 110 4-7

 4.4.3 Special Information 3 : M1,S1,F1 = 111 4-7

 4.4.4 Additional Information 1 : M1,S1,F1 = 001 4-8

 4.4.4.1 Lowest 1T Test Speed: L1..L3 4-8

 4.4.4.2 Highest 1T Test Speed: H1..H4 4-9

 4.4.4.3 Power Multiplication Factor ρ at 1T Test Speed: P1..P3 4-9

 4.4.4.4 Target γ value of the Modulation/Power function at 1T Test Speed: G1..G3 4-10

CD-RW System Description

Table of Contents

4.4.4.5	Recommended erase/write power ratio ε at 1T Test Speed: E1..E3.....	4-10
4.4.4.6	Write-strategy optimization for '1T' Write-strategy at 1T Test Speed.....	4-10
4.4.5	Additional Information 2 : M1,S1,F1 = 010	4-11
4.4.5.1	Lowest '2T' Write-strategy Test Speed L4..L6.....	4-11
4.4.5.2	Highest '2T' Write-strategy Test Speed H5..H8.....	4-12
4.4.5.3	Optimum write power indication at 16x and '2T' Write-strategy	4-12
4.4.5.4	Optimum write power indication at HTS and '2T' Write-strategy	4-12
4.4.5.5	Optimum erase power indication at 16x and '2T' write strategy	4-13
4.4.5.6	Optimum erase power indication at HTS and '2T' write strategy	4-13
4.4.6	Additional Information 3 : M1,S1,F1 = 011	4-14
4.4.6.1	Media technology type: J1..J2.....	4-14
4.4.6.2	Media Identification (MID) code: Q1..Q16	4-14
4.4.6.3	Product revision number: R1..R3.....	4-14
4.5	Error detection.....	4-15
4.6	Bit rate.....	4-15
4.7	ATIP encoder	4-15
5.	Data organization	5-1
5.1	ATIP synchronization rule	5-1
5.2	Linking rules	5-1
5.2.1	General Linking Rules	5-1
5.2.2	Audio Linking.....	5-2
5.2.3	Data Linking.....	5-2
5.2.3.1	Use of RID code in data applications.....	5-4
5.3	Power Calibration Areas.....	5-6
5.3.1	Test Areas	5-6
5.3.2	Count Areas.....	5-7
5.4	Program Memory Area	5-8
5.4.1	Contents	5-8
5.4.1.1	Reserved Track	5-8
5.4.1.2	Incomplete Track	5-9
5.4.2	Recording sequence.....	5-9
5.4.3	The Subcode-Q channel.....	5-10
5.4.3.1	Erasing the PMA with Subcode-Q mode 0	5-12
5.4.4	P, R..W Subcode channels	5-12
5.4.5	RID code in the main channel	5-13
5.5	Lead-in Area.....	5-14
5.5.1	ATIP/Subcode synchronization.....	5-14
5.5.2	Table of Contents	5-14
5.5.2.1	Erasing the Lead-in Area with Subcode-Q mode 0	5-20
5.5.3	Subcode/Header synchronization.....	5-20
5.6	Program Area.....	5-21
5.6.1	ATIP/Subcode synchronization.....	5-21
5.6.2	Subcode/Header synchronization.....	5-21
5.6.3	Subcode Q-Channel.....	5-22
5.6.3.1	Subcode Q-Channel mode 1	5-22
5.6.3.2	Subcode Q-Channel mode 3	5-23
5.6.3.2.1	Data format of the RID code	5-23
5.6.3.2.2	General format of mode 3	5-23
5.6.3.3	Erasing the Program Area with Subcode-Q mode 0.....	5-24
5.6.4	P, R..W Subcode channels	5-24
5.6.5	Data Tracks	5-24
5.6.5.1	The Pre Gap	5-25
5.6.5.2	The Track Descriptor Block	5-25
5.6.5.2.1	The Track Descriptor Table	5-26
5.6.5.2.2	The Track Descriptor Unit.....	5-26
5.6.6	ATIP/Header synchronization.....	5-26
5.7	Lead-out Area.....	5-27
5.7.1	Lead-out Area.....	5-27
5.7.1.1	ATIP/Subcode synchronization.....	5-27

CD-RW System Description

6.	EFM Modulation system.....	6-1
7.	CIRC Error correction system	7-1
8.	Control and display system	8-1
9.	Audio specification	9-1
10.	Digital data structure	10-1
11.	Multisession and Hybrid disc.....	11-1
11.1	Introduction and Definitions.....	11-1
11.2	PCA1, PCA2 and PMA.....	11-1
11.3	Lead-in Areas.....	11-1
11.4	Program Areas.....	11-1
11.5	Lead-out Areas.....	11-1
11.6	Data Retrieval Structure	11-1
11.7	Hybrid disc: disc characteristics	11-1
12.	Figures and Tables	12-1
13.	Attachments	13-1
13.1	Principles of operation.....	13-3
13.1.1	Recorded information	13-3
13.1.2	Tracking Information.....	13-3
13.1.3	Reading at different speeds.....	13-3
13.1.4	Physical Erase	13-4
13.1.5	Logical Erase	13-4
13.1.6	Formatting	13-4
13.2	HF Modulation	13-5
13.2.1	Dependency on Read Pick-up.....	13-5
13.2.2	Dependency on Recorder Pick-up.....	13-5
13.3	Optimum Power Control.....	13-6
13.3.1	Optimum recording power	13-6
13.3.2	Mathematical model for the modulation versus power function	13-7
13.3.3	Procedure for the determination of the OPC parameters for media.....	13-7
13.3.4	An example OPC procedure for recorders	13-8
13.4	Environment: operating and storage conditions	13-10
13.5	Push Pull magnitude and the Normalized Push Pull Ratio.....	13-11
13.6	Measurement of the groove wobble amplitude	13-12
13.7	The use of the Pre-Gap.....	13-14
13.8	The use of addressing Method 1 and Method 2.....	13-16
13.9	Serial Copy Management System (SCMS)	13-18
13.9.1	Scope	13-18
13.9.1.1	General	13-18
13.9.1.2	SCMS implementation	13-18
13.9.2	Normative references	13-18
13.9.3	Technical requirements for CD-RW equipment	13-18
13.9.4	CD-RW playback rules	13-19
13.9.4.1	Channel Status	13-19
13.9.4.1.1	Category code	13-19
13.9.4.1.2	Copyright status bit.....	13-19
13.9.4.1.3	Consumer/Audio bits.....	13-19
13.9.4.2	User data	13-19
13.9.5	CD-RW recording rules	13-20
13.10	Write-strategy optimization.....	13-23
13.10.1	Spot orientation.....	13-23
13.10.2	Write-strategy	13-23
13.10.3	Writing with '1T' strategy at lower speeds than 1T Lowest Test Speed	13-24

List of illustrations

Figure 1-1	Possible states of a Session	1-7
Figure 1-2:	Definition of Radial Difference signal	1-12

CD-RW System Description

Table of Contents

Figure 1-3: Definition of the HF levels	1-12
Figure 2-1 '1T' Write-strategy for 16x nominal CD speed	2-3
Figure 2-2: US24 '2T' Write-strategy, divided into 3T, odd and even mark-lengths	2-4
Figure 2-3: US32 '2T' Write-strategy divided into 3T, odd and even mark-lengths	2-6
Figure 4-1 Definition of the bits and fields in an ATIP frame	4-1
Figure 4-2 Example 1 of the synchronization of the ATIP frames	4-1
Figure 4-3 Example 2 of the synchronization of the ATIP frames	4-2
Figure 4-4 Identification of the extra information in the Lead-in Area	4-2
Figure 4-5 Encoding of ATIP frames in the Lead-in Area	4-3
Figure 4-6 Combinations and definitions of the bits in Special Information 1	4-4
Figure 4-7 Combinations and definitions of the bits in Special Information 2	4-7
Figure 4-8 Combinations and definitions of the bits in Special Information 3	4-7
Figure 4-9 Combinations and definitions of the bits in Additional Information 1	4-8
Figure 4-10 Combinations and definitions of the bits in Additional Information 2	4-11
Figure 4-11 Combinations and definitions of the bits in Additional Information 3	4-14
Figure 4-12 Block diagram of a typical ATIP encoder	4-15
Figure 5-1 Layout of a Packet	5-2
Figure 5-2 Layout of the Mode byte	5-3
Figure 5-3 Definition of the User Data bytes in the Run-in and Run-out blocks	5-4
Figure 5-4 Encoding in the PMA of a Subcode-Q frame	5-10
Figure 5-5 Encoding in the PMA of a Subcode-Q mode 0 frame	5-12
Figure 5-6 Definition of the User Data bytes in the PMA main channel blocks	5-13
Figure 5-7 Encoding in the Lead-in Area of a Subcode-Q frame	5-15
Figure 5-8 Encoding in the Lead-in Area of a Subcode-Q mode 0 frame	5-20
Figure 5-9 Example of start positions for recordings in unrecorded areas	5-21
Figure 5-10 Encoding in the Program Area of a Subcode-Q mode 1 frame	5-22
Figure 5-11 Encoding in the Program Area of a Subcode-Q mode 3 frame	5-23
Figure 5-12 Encoding in the Program Area of a Subcode-Q mode 0 frame	5-24
Figure 5-13 Linking of the first User Data in the Track to the Pre Gap	5-25
Figure 12-1 Layout of the Unrecorded disc	12-3
Figure 12-2 Example of the layout of a Partially Recorded disc with one Session	12-3
Figure 12-3 Example of the layout of a Finalized disc with one Session	12-3
Figure 12-4 Operating conditions	12-4
Figure 12-5 Maximum allowed time errors versus frequency spectrum	12-5
Figure 12-6 ATIP versus disc diameters	12-6
Figure 12-7 Organization of the PCA1, PMA and Lead-In Area	12-7
Figure 12-8 Organization of the PCA2 area in the Additional Capacity & Lead out Area	12-8
Figure 12-9 Synchronization rules	12-9
Figure 12-10 General linking rules	12-9
Figure 12-11 Linking rules for audio & data	12-10
Figure 12-12 Program Memory Area (example 1)	12-11
Figure 12-13 Program Memory Area (example 2)	12-12
Figure 12-14 Table of Contents in the Lead-in Area of an Audio disc	12-13
Figure 12-15 Table of Contents in the first Lead-in Area of a Multisession Data disc	12-14
Figure 12-16 The User Data Field in the Track Descriptor Block of Data Track 4 (Mode=1)	12-15
Figure 12-17 Example of the layout of a Multisession disc	12-16
Figure 12-18 Details of the centre hole, clamping and stacking ring areas	12-17
Figure 12-19 Outer Rim Height detail at outer diameter of the disc	12-18
Figure 12-20 Allowed Outer Rim Height values in relation with the substrate thickness	12-18
Figure 13-1 Main differences of logically erased and formatted discs	13-4
Figure 13-2 Modulation and Gamma versus Power function	13-6
Figure 13-3 Modulation times Power versus Power function	13-7
Figure 13-4 The radial error signal	13-13
Figure 13-5 The groove wobble	13-13
Figure 13-6 Contents of the first and second part of the Pre Gap (1 and 2 in the table)	13-15
Figure 13-7 Example of addressing Method 1 and 2	13-17
Figure 13-8 CD-RW playback rules: Channel Status	13-19
Figure 13-9 CD-RW Recording Rules for all allowed input signals	13-21
Figure 13-10 SCMS logic diagram	13-22
Figure 13-11: Recommended drive action with respect to unknown media	13-24

List of tables

Table 1: CD-RW Disc types and their sub-type identification.....	1-1
Table 2-1 '2T' Write-strategy parameter ranges.....	2-5
Table 2-2 '2T' Write-strategy parameter ranges.....	2-7

This Ecma Standard has been adopted by the General Assembly of December 2010.

"DISCLAIMER

This document and possible translations of it may be copied and furnished to others, and derivative works that comment on or otherwise explain it or assist in its implementation may be prepared, copied, published, and distributed, in whole or in part, without restriction of any kind, provided that the above copyright notice and this section are included on all such copies and derivative works. However, this document itself may not be modified in any way, including by removing the copyright notice or references to Ecma International, except as needed for the purpose of developing any document or deliverable produced by Ecma International (in which case the rules applied to copyrights must be followed) or as required to translate it into languages other than English.

The limited permissions granted above are perpetual and will not be revoked by Ecma International or its successors or assigns.

This document and the information contained herein is provided on an "AS IS" basis and ECMA INTERNATIONAL DISCLAIMS ALL WARRANTIES, EXPRESS OR IMPLIED, INCLUDING BUT NOT LIMITED TO ANY WARRANTY THAT THE USE OF THE INFORMATION HEREIN WILL NOT INFRINGE ANY OWNERSHIP RIGHTS OR ANY IMPLIED WARRANTIES OF MERCHANTABILITY OR FITNESS FOR A PARTICULAR PURPOSE."

CD-RW System Description

Table of Contents

This page is intentionally left blank

1. General

1.1 Scope

The CD ReWritable (CD-RW) system gives the opportunity to write, erase, overwrite and read CD information. The recorded CD-RW disc has a lower reflectivity than a "Red Book compatible" disc, so it must be played back on "CD-RW enabled CD-players". A CD-RW enabled CD-player can read out CD-RW discs described in this document, as well as CD-R and conventional CD discs. The CD-RW format gives the possibility for both Audio and Data recording.

1.2 General Description

In the CD-RW system the disc contains a recording material which shows a reflection decrease due to writing, a reflection increase due to erase, and a reflection decrease or increase due to overwriting. The CD-RW disc has a lower reflectivity in comparison with conventional CD discs, but satisfies almost all the remaining specifications as written in the chapter DISC SPECIFICATION of the Red Book. The CD-RW disc contains a wobbled pre-groove for tracking, CLV speed control and timing purposes. Recording takes place in the groove. The CD-RW system is described in the Orange Book, Part III. Volume 1 describes the 1-4x disc type; Volume 2 describes the 4-10x (High Speed) type. **Volume 3 (this document) defines two types of Ultra Speed CD-RW discs:**

- US24, an 8x-24x disc type that is compatible with Orange Book, Part III, Volume 3, Version 1.0.
- US32, an 8x-32x disc type that is write-incompatible with version 1.0. A new logo shall be used for US32 discs only:



The disc type shall be indicated by the 'Sub-type' code B1..B3 in the ATIP code, see paragraph 4.4.1.5, according to the Table 1:

Disc type:	sub-type: B1..B3	OB Part III, Volume:
1-4x	000	1
4-10x	001	2
8-24x (US24)	010	3
8-32x (US32)	011	3

Table 1: CD-RW Disc types and their sub-type identification

Remark 1:

Like the CD-DA system (Red Book, pages 84 up to 86), the CD-RW system offers the possibility of an 8 cm "CD-single".

Remark 2:

When the chapter DISC SPECIFICATION of the Red Book is being referred to, pages 74 up to 83 are excluded (description of CD-Video).

Remark 3:

For Data applications, the term "Red Book" in this document must be replaced by "Yellow Book" or "ISO 10149" or "Green Book" if necessary for recording Data instead of Audio information.

1.3 References and conformance

CD-RW Ultra-Speed conforms to the mandatory requirements specified in this document. All parts in this document are mandatory unless they are specially defined as recommended or optional or informative.

Note:

Due to advances in technology and market requirements, System Descriptions might need to be extended after some time. This could mean that new items, such as e.g.: new subcode modes and pointers, new ATIP formats, new data structures or definitions for reserved bits/bytes, may have to be added to a System Description.

System designers should take notice of this in the design of their equipment.

CD-RW Ultra-Speed also conforms to the applicable parts of the System Descriptions or international standards that are listed below:

- CD-DA: Compact Disc Digital Audio, specified in the System Description Compact Disc Digital Audio ("Red Book"), Royal Philips Electronics and Sony Corporation. . (see also IEC 60908: 1987)
- CD-ROM: Compact Disc Read Only Memory, specified in the System Description Compact Disc Read Only Memory ("Yellow Book"), Royal Philips Electronics and Sony Corporation. (see also ISO/IEC 10149: 1995)
- CD-i: Compact Disc Interactive, specified in the CD-i Full Functional Specification ("Green Book"), Royal Philips Electronics and Sony Corporation.
- CD-ROM XA: Compact Disc Read Only Memory eXtended Architecture, specified in the System Description CD-ROM XA, Royal Philips Electronics and Sony Corporation.
- CD-R: Compact Disc Recordable, specified in the System Description Recordable Compact Disc Systems, part II: CD-R, volume 1: 1x/2x/4x ("Orange Book"), Royal Philips Electronics and Sony Corporation.
- CD-R MS: Compact Disc Recordable Multi-Speed, specified in the System Description Recordable Compact Disc Systems, part II: CD-R, volume 2: Multi-Speed ("Orange Book"), Royal Philips Electronics and Sony Corporation.
- CD-WO: Compact Disc Write Once: name changed to CD-R.

- **CD-RW:** Compact Disc ReWritable, specified in the System Description Recordable Compact Disc Systems, part III: CD-RW, volume 1: 1x/2x/4x ("Orange Book") and part III: CD-RW, volume 2: 4x-10x ("Orange Book") Royal Philips Electronics and Sony Corporation.
- **Multisession CD:** Multisession Compact Disc, specified in the Multisession Compact Disc Specification, Royal Philips Electronics and Sony Corporation.
- **CD-logos:** CD Logo Guide, Royal Philips Electronics
- **ISO 646:** Information processing ISO 7-bit coded character set for information interchange. Ref. No. ISO 646 : 1983 (E).
- **Reference Measuring Methods:**
CD-Reference Measuring Methods, Specification Guidelines, Royal Philips Electronics and Sony Corporation

1.4 Definitions

1.4.1 General

- $\langle x \rangle$: $\langle x \rangle$ denotes the average value of parameter x.
 Δx : $\Delta x = x - \langle x \rangle$ denotes the deviation of the instantaneous value of parameter x from the average value.
- ATER** : **ATIP Error Rate.** Number of erroneous ATIP frames in proportion to the total number of frames, averaged over any 10 seconds.
- ATIP** : **Absolute Time In Pre-groove.** With an additional modulation of the "Wobble", the "Groove" contains a time-code information called ATIP, see chapter 4.
- Audio disc** : A recorded disc which is not a Data disc.
Audio Session : A Session containing Audio Tracks only.
Audio Track : A Track which is not a Data Track.
- Block** : A unity of 2352 bytes as defined in the Yellow Book (page 100).
- CD-RW enabled CD-player:** A CD-audio or CD-ROM drive which meets the requirements of reading data from CD-RW media.
- CLV** : **Constant Linear Velocity** is the speed with which the pre-groove or the recorded marks (or pits) and lands on the disc pass the laser spot in tangential direction.
- Consumer CD-recorder** : A CD-recorder designed and manufactured for consumer use and solely for recording signals in accordance with the CD-DA Format (Red Book).
- CW** : **Continuous Wave.** The laser light output is at a constant level.
CW-Erase : See Physical Erase.
- Data disc** : A disc on which every Session contains one or more Data Tracks.
- Data Session** : A Session containing one or more Data Tracks.
Data Track : A Track which is designated as "Data Track" in CONTROL of the subcode Q-channel.
- Direct OverWrite (DOW)** : The action in which new information is recorded over previously recorded information.

CD-RW System Description

DOW(n)	:	Denotes the n th overwrite cycle.
Effect length	:	The average length of a specific (I3 .. I11) mark (pit) or land, as measured by Time Interval Analysis (see Red Book).
EFM	:	E ight to F ourteen M odulation. See chapter 6.
EFM frame	:	A group of 588 channel bits, representing an EFM sync pattern, one byte of subcode information, 24 bytes of user data and 8 bytes of CIRC error correction parity symbols (see Red Book). The duration at nominal speed equals about 136 μ sec.
Finalization	:	The action in which (partially) unrecorded or logically erased tracks are finished and the Lead-in and/or Lead-out areas are recorded or overwritten with the appropriate TOC subcode.
Final Session	:	The last Session on a CD-RW disc can be designated as the Final Session. Addition of Sessions after the Final Session is not possible.
FWHM	:	Full Width Half Maximum
(pre-) Groove	:	The guidance track in which clocking and time-code information is stored by means of an FM modulated wobble.
Hybrid Disc	:	A Multisession disc of which the first Session is mastered. On a hybrid disc, recorded and mastered information may co-exist.
Jitter	:	The 1σ value of the time variations between leading and trailing edges of a specific (I3..I11) mark (pit) or land as measured by Time Interval Analysis (see Red Book).
Land	:	Land is characterized in the following way: When radial signals are concerned, land is defined as the area between the grooves. When HF signals are concerned, land is defined as the area between the marks (pits) in tangential direction.
Laser Modulation	:	During recording, the laser is switched on and off according to the "Write-strategy".
Logical Erase	:	A method to remove information from a disc area by overwriting it with an EFM signal containing mode 0 subcode according to chapter 5.4.3.1, 5.5.2.1 or 5.6.3.3 (see also attachment 13.1.4, 13.1.5 and 13.1.6). A logically erased area is equivalent to an unrecorded area and has to be treated in the same way.
Marks	:	Recorded I3 .. I11 effects, where $I = 1T$ length = 1 clock period.
Mastered information	:	Information, stored as pits on the disc during the manufacturing process of the disc (when making the "master").
MID	:	Media IDentification code, see paragraph 4.4.6.2
Multisession disc	:	A disc that contains or can contain more than one Session (indicated in the first Lead-in area in mode 5 of the subcode Q-channel).
m11	:	Denotes the modulation I11/I _{top} , obtained under test conditions described in chapter 2.3.
<m11>	:	Denotes the average I11/I _{top} over a disc, obtained under test conditions described in chapter 2.3.
Nominal CD Speed	:	The CLV that will result in an average EFM bitclock frequency of 4.3218 MHz or in an average pre-groove wobble frequency of 22.05 kHz.

Nx nominal CD speed	: A CLV speed, which is N times the Nominal CD Speed.
Normalized Push-Pull Ratio (NPPR)	: The resulting value, when the normalized push pull amplitude before recording is divided by the normalized push pull amplitude after recording. See also chapter 1.4.4: Signals after recording. <ul style="list-style-type: none"> - Push pull amplitude before recording is normalized to the groove level I_g before recording (see chapter 1.4.4). - Push pull amplitude after recording is normalized to the averaged groove level I_{ga} after recording (see chapter 1.4.4).
OPC	: Optimum Power Control : see attachment 13.3.
Overwrite	: The action in which new information is recorded over previously recorded information.
PBO	: The optimum bias power.
PECW	: The power for a CW-Erase action.
PEO	: The optimum erase power for the creation of "lands" during a recording or overwrite action.
P_{WO}	: The optimum write power for the creation of "marks" during a recording or overwrite action, as determined by the OPC procedure.
PCA	: Power Calibration Area : see chapter 1.4.2.
Physical Erase	: The action in which previously recorded information is erased by overwriting with a CW laser output. After a Physical Erase action, the erased area on the CD-RW disc is in the unrecorded state again. (see attachment 13.1.4)
Pits	: Mastered or recorded I3..I11 effects.
PMA	: Program Memory Area : see chapter 1.4.2.
Pre-groove	: The guidance track in which clocking and time-code information is stored by means of an FM modulated wobble.
Professional CD-recorder:	A CD-recorder designed and manufactured for professional use and solely for recording signals in accordance with the CD-DA Format (Red Book), the CD-ROM Format (Yellow Book) and/or the CD-i Format (Green Book). Note: this professional category includes all CD-recorders other than "Consumer CD-recorders".
Random EFM	: Random EFM data are characterized by: <ul style="list-style-type: none"> - In the main channel: random data symbols (e.g. a recorded white noise audio signal). - In the subcode channel: all subcode bytes, except the sync and the CRC, must be set to a fixed value per subcode frame, preferably "FF" or "00".
Recorded Information	: Information, stored as marks on the disc during the recording or overwrite process of the CD-RW disc.
Reserved	: "Reserved" in relation to a value means: the specified value(s) shall not be used. In future standards, these value(s) can be assigned. "Reserved" in relation to a field means: the use of the field(s) is not specified and the value(s) in the field(s) must be set to zero. In future standards, the use of these fields can be defined.

Session	:	An area on the disc consisting of a Lead-in area, a Program area and a Lead-out area.
Single Session disc	:	A disc which is not a Multisession disc.
Stacking ring area	:	The ring area between the clamping and the information area. In this area diverse shapes with protrusions and recesses are allowed, both on the read-out and label side. It is called the stacking ring area as this area is most used for creating a stacking ring at the read-out side of the disc. See Figure 12-18
TDB	:	T rack D escriptor B locks in the Pre Gap of a data Track contain information about the Track attributes. (see chapter 5.6.5)
TOC	:	T able O f C ontents: in the Lead-in Area the subcode Q-channel contains information about the Tracks on the disc.
Unbalance of disc U_d	:	$U_d = m_d * r$ [g.mm], in which m_d = mass [grammes] of disc and r = distance [millimetres] between centre of gravity and geometrical centre of disc. When the disc is rotating at a rotational frequency f_{rot} [Herz], then the resulting Unbalance Force becomes $F_U = U_d * \omega^2 * 10^{-6}$ [Newton], in which $\omega = 2\pi * f_{rot}$.
Unrecorded area	:	An area in which no signal has been recorded, or in which a previously recorded signal has been physically erased. The track (groove) is in the high-reflective state.
User-recorded area	:	An area (or Track) recorded with an EFM signal containing User Data and normal Subcode Q (not mode 0).
US24	:	8x – 24x Ultra Speed disc. Disc type indicated by B1..B3 = 010 (Special Information 1)
US32	:	8x – 32x Ultra Speed disc type. Disc type indicated by B1..B3 = 011 (Special Information 1)
Variation	:	The variation of a parameter x is defined as the ratio $\Delta x / \langle x \rangle$.
Wobble	:	The pre-groove in the disc is not a perfect spiral but is wobbled with: - a typical amplitude of 30 nm, - a spatial period of 54 to 64 μm . (See chapter 4)
Write	:	The action in which information is recorded in an unrecorded area of the CD-RW disc.
Write-strategy	:	The shape of the HF write signal used to modulate the power of the laser. The Write-strategy, that must be used for recordings necessary for disc measurements, is described in chapter 2.1.3: Write strategies for media testing.

1.4.2 Disc Lay-out

The recorded area on a disc can be subdivided into Sessions, where a **Session** consists of a Lead-in Area, a Program Area and a Lead-out Area.

A Session is called finalized, when the Program Area does not have unrecorded or logically erased areas and the Lead-in Area and the Lead-out Area both have been recorded with the appropriate subcode mode 1 and mode 5.

A Session is called non-finalized, when the Lead-in Area and the Lead-out Area are unrecorded or logically erased.

All possible states of a Session are defined in Figure 1-1.

Program Area	Lead-in & Lead-out area	Session state
contains unrecorded and/or logically erased areas	recorded with subcode mode 1 & 5	not allowed
contains unrecorded and/or logically erased areas	unrecorded or logically erased	<u>non-finalized</u>
fully User-recorded	unrecorded or logically erased	<u>non-finalized</u>
fully User-recorded	recorded with subcode mode 1 & 5	<u>finalized</u>

Figure 1-1 Possible states of a Session

In general, three **recording states of the disc** are defined:

- the Unrecorded disc, of which the layout is given in Figure 12-1.
- the Partially Recorded disc, of which an example of a layout (for a single Session) is given in Figure 12-2.
- the Finalized disc, of which an example of a layout (for a single Session) is given in Figure 12-3.

In case of a Multisession disc, the last Session may be partially User-recorded (non-finalized) or finalized; all previous Sessions must be finalized. An example of a Multisession disc is given in Figure 12-17.

Remarks:

- Only Finalized Sessions can in general be played back on CD-RW enabled CD players.
- For further descriptions of each disc area, see chapter 5.
- For further descriptions of the Multisession disc, see chapter 11.

Unrecorded disc:

The Information Area of an unrecorded CD-RW disc contains a pre-groove with CLV clocking information (wobble) and a time-code (ATIP).

In addition to the time-code encoded in ATIP, during the Lead-in Area the CD-RW disc also contains extra information, such as: disc identification, write power, speed range and OPC parameters (see chapter 4).

Partially Recorded disc:

The Data Organization of the partially recorded disc is defined in chapter 5 and includes:

- 1: Power Calibration Areas (PCA1 and PCA2): partially recorded.

PCA1 and PCA2 are reserved for determining the correct recording power of a disc, see chapter 5.3. All 100 partitions of each PCA are used sequentially. Once all 100 partitions of a PCA have been used, the complete PCA (Test Area and Count Area) can be erased and used again.

- 2: Program Memory Area (PMA): partially recorded.

The PMA must reflect the complete track information of all Sessions on the CD-RW disc. (see chapter 5.4)

remark: In case the *Incomplete Track* features are used, the PMA may not always reflect the exact track information of the Program Area (see chapter 5.4.1.2).

- 3: One or more Session(s):

all Sessions, except the last Session: *finalized*.

Lead-in Area: recorded with subcode mode 1 & 5

The Lead-in Area has been recorded with the **Table Of Contents** according to the specifications in chapter 5.5.

Program Area: User-recorded

In the Program Area the Tracks with user information have been recorded according to the specifications in chapter 5.6.

Lead-out Area: recorded with subcode mode 1 & 5

The Lead-out Area has been recorded according to the specifications in chapter 5.7 or chapter 11.5.

the last (or only) Session: *non-finalized*.

Lead-in Area: unrecorded or logically erased

This area is reserved for the recording of the Lead-in Area with the **Table Of Contents** according to the specifications in chapter 5.5.

Program Area: partially User-recorded

In the Program Area the Tracks with user information have been or will be recorded according to the specifications in chapter 5.6.

Lead-out Area: unrecorded or logically erased

This area is reserved for the recording of the Lead-out Area according to the specifications in chapter 5.7 or chapter 11.5. This area starts right after the Program Area. When finalizing a Session, the Lead-out is recorded right after the last User-recorded Track.

Finalized disc:

A finalized disc is a disc in which all Sessions are finalized.

A finalized Session is a Session with a fully User-recorded Program Area (no unrecorded or logically erased areas), a Lead-in Area with a Table Of Contents reflecting the track information of the related Program Area, and a Lead-out Area.

After finalizing the disc, all Sessions can in general be played back on CD-RW enabled CD players.

1.4.3 Writing modes

The CD-RW system gives the opportunity to write or overwrite information in different interrupted write actions e.g. at a different time, on a different recorder. Overwriting on a CD-RW disc can take place as well in non-finalized as in finalized Sessions.

After overwriting previous information, all linking rules still have to be fulfilled. This means that in data tracks, overwriting is only allowed between two existing link points.

A CD-RW recorder in general can use the following writing modes:

Uninterrupted writing: - Disc At Once (DAO),

Incremental writing: - Session At Once (SAO),
- Track At Once (TAO),
- Packet writing.

A **summary of the main characteristics** of these writing modes is given below. The detailed requirements for (over)writing and linking can be found in chapter 5.

DAO: complete disc is written in one write action

All areas are written in one uninterrupted write action:

- the Track information of the disc is recorded in the Lead-in Area (and optional in the PMA);
- subcode mode 5, point=B0 in the Lead-in Area indicates "final Session";
- no link points are used;

⇒ adding data or partial overwriting of data is not possible; only overwriting of the complete disc is possible.

SAO: complete Session is written in one write action

Lead-in Area, Program Area and Lead-out Area are written in one uninterrupted write action:

- the Track information of the Session is recorded in the Lead-in Area and in the PMA;
- subcode mode 5, point=B0 in the Lead-in Area gives the start of the next Program Area;

⇒ adding data in a new Session or overwriting of an existing Session is possible.

TAO: complete Track is written in one write action

Pre Gap + Track content + Post Gap are written as one packet:

- the start and stop time of the Track are recorded in the PMA;
- the Track starts and ends with a link point;

⇒ adding data in a new Track or overwriting of an existing Track is possible.

Packet writing:

writing of fixed or variable size packets in an Incomplete Track or Reserved Track

The Track has to be initialized by writing the Pre Gap with Track Descriptor Blocks. The Pre Gap ends with a link point:

- the start time and stop time of the Track are recorded in the PMA;
- each added packet starts and ends with a link point;

⇒ packets can be added to the Track or existing packets can be overwritten.

1.4.4 Signals

Signals before recording:

I_0 : *Blank area level*

I_1 : *Land level*

I_g : *Groove level before recording*

$RC_b = 2 * \frac{(I_1 - I_g)}{(I_1 + I_g)}$: *Radial Contrast before recording*

$\frac{|I_1 - I_2|}{I_g}$ at 0.1 μ m radial offset : *Push Pull magnitude before recording*
($I_1 - I_2$) is measured after low pass filtering ($f < 5$ kHz). For explanation, see attachment 0 and Red Book chapter 15.1.

$I_W = (I_1 - I_2)$

: *Wobble signal*
($I_1 - I_2$) is measured after band-pass filtering ($10 \text{ kHz} < f < 30 \text{ kHz}$).

$\frac{I_{W(rms)}}{|I_1 - I_2|_{(pp)}}$

: *Normalized wobble signal*
See attachment 0.

Signals after recording:

I_{top}

$I_{ga}, (I_{la})$

: *Top level of recorded I11 signal*
See Red Book chapter 14.

$RC_a = 2 * \frac{(I_{la} - I_{ga})}{(I_{la} + I_{ga})}$

: *Averaged groove (land) level after recording*
 I_{ga} (I_{la}) is defined as the averaged HF signal ($\tau = 15 \mu$ s), measured in the groove (on land), before AC coupling.

$RD = \frac{|I_1 - I_2|_{AC}}{(I_1 + I_2)_{DC}}$

: *Radial Contrast after recording*

$\frac{I_3}{I_{top}}, \frac{I_{11}}{I_{top}}$

: *Radial Difference Signal used for read-out of shorter wavelengths, see paragraph 2.4 and Figure 1-2*

- $\frac{I_3}{I_{11}}$: Modulation amplitudes of I3 and I11 signals
 See Red Book chapter 14.
- $\frac{|I_1 - I_2|}{I_{top}}$ at 0.1 μ m radial offset : Ratio of I3 and I11 signals
- $R_{top} = R_0 * \frac{I_{top}}{I_0}$: Push Pull magnitude after recording
 (I1-I2) is measured after low-pass filtering (f < 5 kHz). For explanation, see attachment 0 and Red Book chapter 15.1.
- $\frac{|I_1 - I_2| / I_g}{(|I_1 - I_2|)_a / I_{ga}}$: Reflectivity of the recorded disc relative to Itop
 R0 is the reflectivity of a blank area of the disc.
- $Asym = \left\{ \frac{AVG(I_{slice})}{AVG(I_{11})} - \frac{1}{2} \right\} * 100\%$: Normalized Push Pull Ratio (NPPR)
 See chapter 1.4.1 and attachment 0.
 - $|I_1 - I_2| / I_g$ is measured before recording.
 - $(|I_1 - I_2|)_a / I_{ga}$ is measured after recording
- : Asymmetry
 Indicates the position of the I₃ in the HF signal.
 Definition according Red Book and IEC 908.
 For details: see Figure 1-3 and [Reference Measuring Methods]

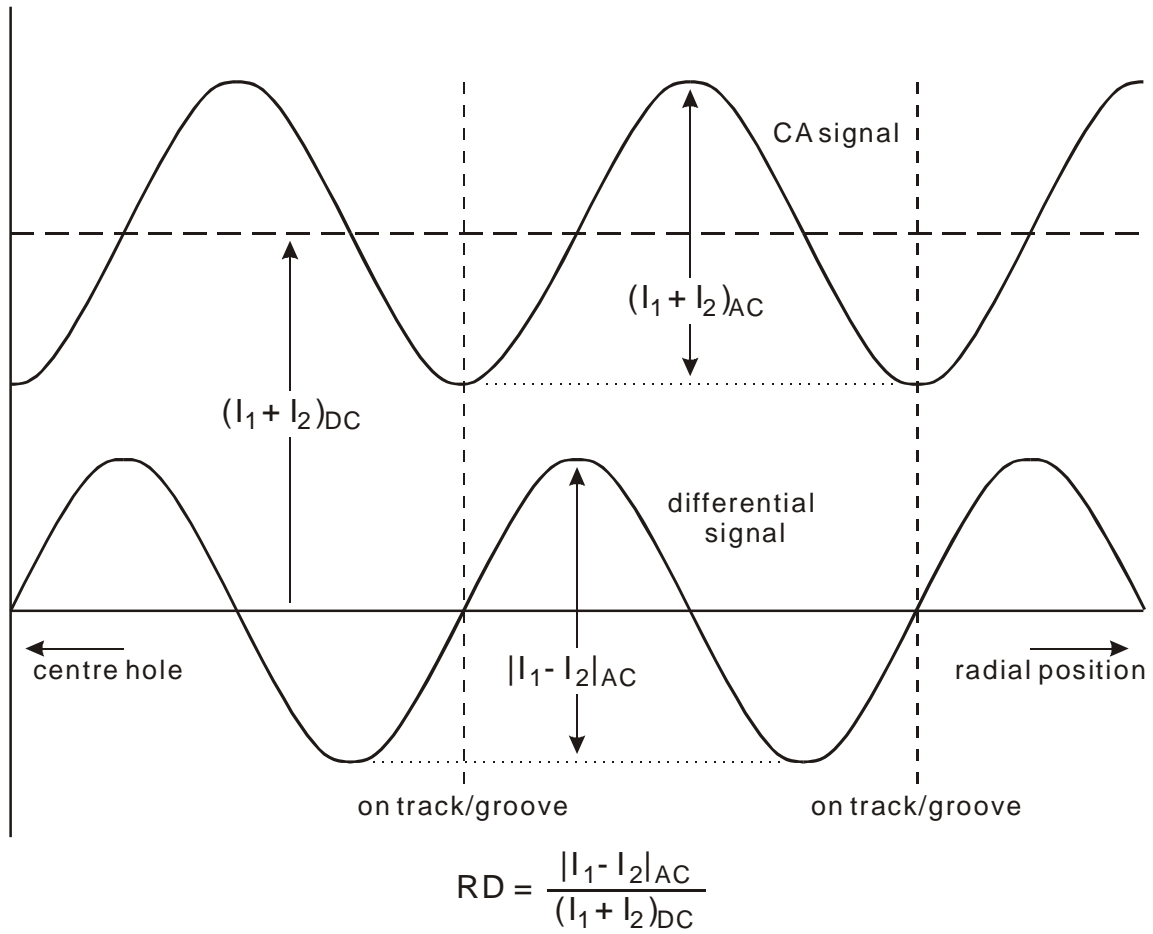

Figure 1-2: Definition of Radial Difference signal

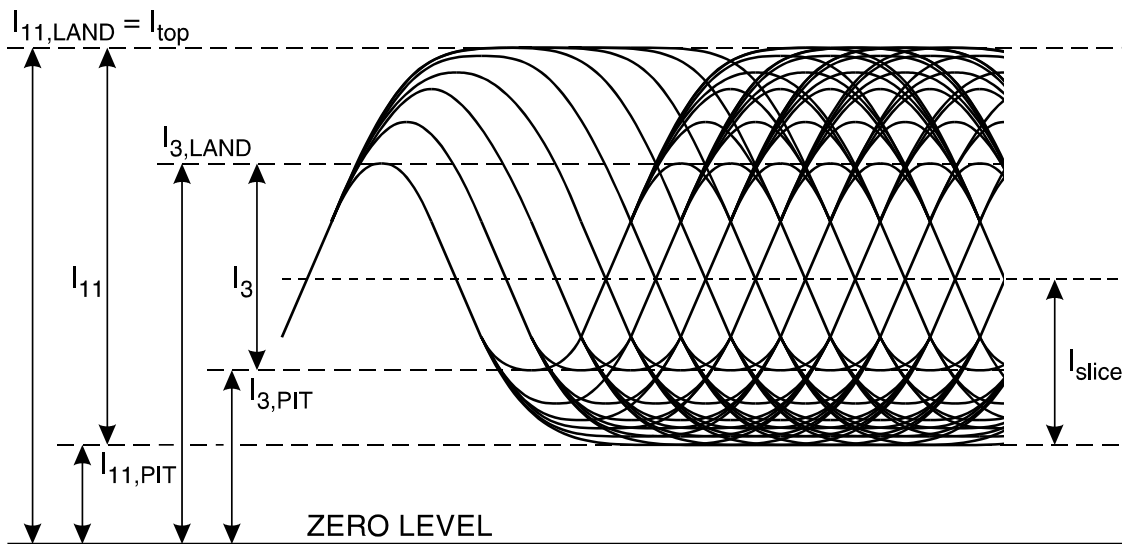

Figure 1-3: Definition of the HF levels

2. Disc Specification

2.1 General

In this chapter the atmospheric conditions, the optical pick-up unit and the Write-strategy are defined, which must be used for test recording and measurement of all characteristics.

2.1.1 Standard atmospheric conditions for testing.

Measurements and mechanical checks are to be carried out at any combination of temperature, humidity and air pressure within the following limits, unless otherwise specified:

Ambient temperature	: 23 °C ± 2 °C
Relative humidity	: 45% to 75%
Air pressure	: 86 kPa to 106 kPa.

2.1.2 The optical pick-up unit for disc measurements.

Three different optical pick-up units are defined for measurements:

(1) The "**Read Only optical pick-up**" for measurement of the characteristics in chapter 2.3: "The recorded disc", except jitter & effect length.

The specification of this pick-up unit is equal to the specification of the pick-up in the Red-Book on page 2:

Wavelength	: 780 ± 10 nm
NA	: 0.45 ± 0.01
Polarization	: circular
Wavefront distortion	: < 0.05 λ (RMS value)
Rim intensities:	
Tangential	: > 0.5
Radial	: > 0.5
Laser read power	: < 0.7 mW, CW in the central spot.

(2) The "**Read Only optical pick-up**" for measurement of **jitter & effect length**, see chapter 2.3.14 and attachment 13.2:

Wavelength	: 780 ± 10 nm
NA	: 0.45 ± 0.01
Polarization	: perpendicular to the tracks
Wavefront distortion	: < 0.05 λ (RMS value)
Rim intensities:	
Tangential	: > 0.7
Radial	: > 0.5
Laser read power	: < 0.7 mW, CW in the central spot.

remark 1:

All signal measurements are done **without read equalization**. In practical players and recorders however, read equalization is recommended in order to improve margins.

remark 2:

Implementation of "Write-strategy" and "Recorder optical pick-up" in recorders.

In a recorder, the choice of beam profile and Write-strategy is free, however, they should be matched in such a way that all signals from a disc, recorded with the specific optical pick-up and Write-strategy, are within the specifications as mentioned in this chapter.

The above mentioned optical pick-ups (1, 2 and 3, each of them optimized for some specific measurements) are only specified for **media testing**.

- (3) The "**Recorder optical pick-up**" for measurement of all characteristics in chapter 2.2: "The unrecorded disc", and for the recordings which are necessary for disc measurements. The specification of this pick-up unit is (at $P_W = 24$ mW and $T_{\text{ambient}} = 23 \pm 2$ °C):

Wavelength : 786 ± 2 nm
NA : 0.50 ± 0.01
Polarization : circular
Wavefront distortion : $< 0.05 \lambda$ (RMS value)

Spot shape and orientation:

Shape : oval spot
Orientation : angle of axes relative to the track = $45^\circ \pm 5^\circ$

Intensities at RIM of aperture:

in direction of highest intensity : 0.57 ± 0.05
in direction of lowest intensity : 0.17 ± 0.05

FWHM of intensity in direction of lowest intensity: 0.55 ± 0.03 of full aperture diameter

Laser power:

Reading : < 1.0 mW, CW in the central spot.
Writing : according to "Write-strategy" and "OPC", see below.

2.1.3 Write strategies for US24 and US32 media testing

US24 and US32 disc types require a separate set of testing conditions.

2.1.3.1 US24 media testing

For the US24 disc type, during the recordings necessary for disc measurements, using the "recorder optical pick-up (3)" specified above, the laser power is modulated according to 2 different write strategies :

1. '1T' Write-strategy is applied at 1T Test Speed (16x). This Write-strategy is similar to Orange Book Part III Volume 2.
2. '2T' Write-strategy is applied between LTS (8x) and HTS (24x).

2.1.3.1.1 US24 media testing with '1T' Write-strategy

For 1T Test Speed = 16x nominal CD speed only.

Each I_n mark ($n=3..11$) is recorded by applying a **Write Pulse Train (WPT)** consisting of $(n-1)$ pulses, with T the length of one clock cycle (see Figure 2-1).

The first pulse of each I_n WPT is preceding the clock edge at 1T after the start of the EFM signal by dT_{top} and is T_{top} in length. All remaining pulses start at each following clock edge and are T_{mp} in length. For each I_n WPT, the end of the WPT is located at dT_{era} relative to the end of the EFM signal. dT_{top} and dT_{era} can be tuned to get optimum signal characteristics (asymmetry, modulation and jitter). Indicative values for dT_{top} and dT_{era} are given in ATIP (see chapter 4.4.4). The power level during any write pulse is called the write level (PW). The power level after each pulse within the WPT is called the bias level (PB). The power level between each I_n WPT is called the erase level (PE).

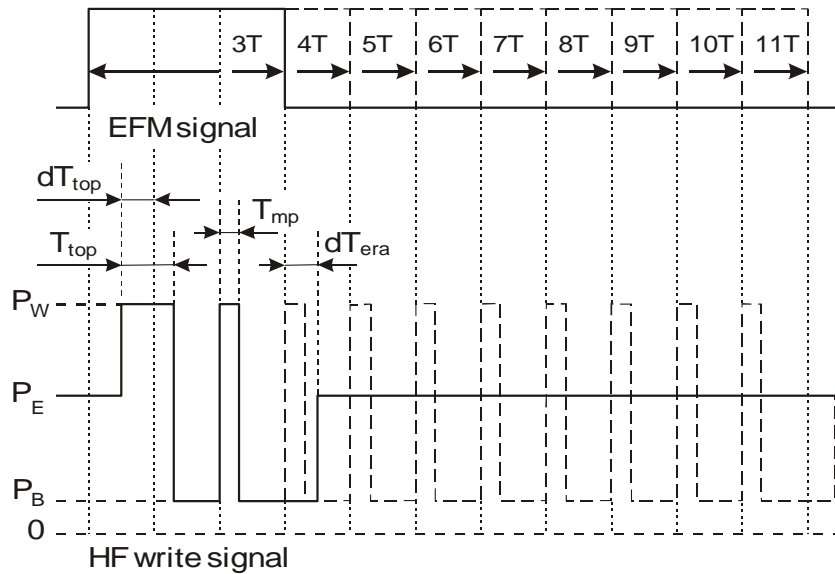

Figure 2-1 '1T' Write-strategy for 16x nominal CD speed

$T_{mp} = 3.6 \text{ ns}$ (= $4T/16$ at actual speed)

$T_{top} = T_{mp} + dT_{top}$, where

$dT_{top} = m \cdot T/16$ (T at actual speed), with $m = 0, 1, 2, 3$

$dT_{era} = n \cdot T/8$ (T at actual speed), with $n = -1, 0, 1, 2$

(negative values are lagging as indicated in Figure 2-1)

The values of m and n are indicated in the ATIP (see chapter 4.4.4.6)

Rise and fall times of all signal transitions (from 10% to 90% of step size) shall be $\leq 1.4 \text{ ns}$.
Signal overshoots shall be $\leq 10\%$ of the step size.

2.1.3.1.2 US24 media testing with '2T' Write-strategy

This Write-strategy is divided into even and odd mark lengths and a separately specified 3T mark length (see Figure 2-2).

Each even mark I_n ($n = 4, 6, 8$ and 10) is recorded by applying a **Write Pulse Train** (WPT) consisting of $n/2$ pulses. The first pulse of each even I_n WPT starts on the clock edge at 1T after the start of the EFM signal and has a length of T_{mp} . All remaining pulses also have a length of T_{mp} and repeat every 2T. The WPT is ended by a cooling gap with a length of T_c .

Each odd mark is recorded by applying $(n-1)/2$ pulses. The first pulse of each $I_{5,7,9,11}$ WPT starts on the clock edge at 1T after the start of the EFM signal and has a length of T_{mp} . All remaining pulses but the last also have a length of T_{mp} , and repeat every 2T. The last pulse has a length of $T_{mp} + \Delta_1$. The gap before the last pulse also has a length extension of Δ_1 . The WPT is ended by a cooling gap with a length of $T_c + \Delta_2$.

The I_3 mark is recorded by applying 1 pulse. This pulse has a length of T_3 . dT_3 is the time difference between the start of a T_3 pulse and the start of an $I_4 \dots I_{11}$ strategy sequence. Negative values are leading as indicated in Figure 2-2. The length of the cooling gap after the 3T pulse is T_{C3} . The power level during any write pulse is called the write level (P_W). The power level after each pulse within the WPT is called the bias level (P_B). The power level between each I_n WPT is called the erase level (P_E).

CD-RW System Description

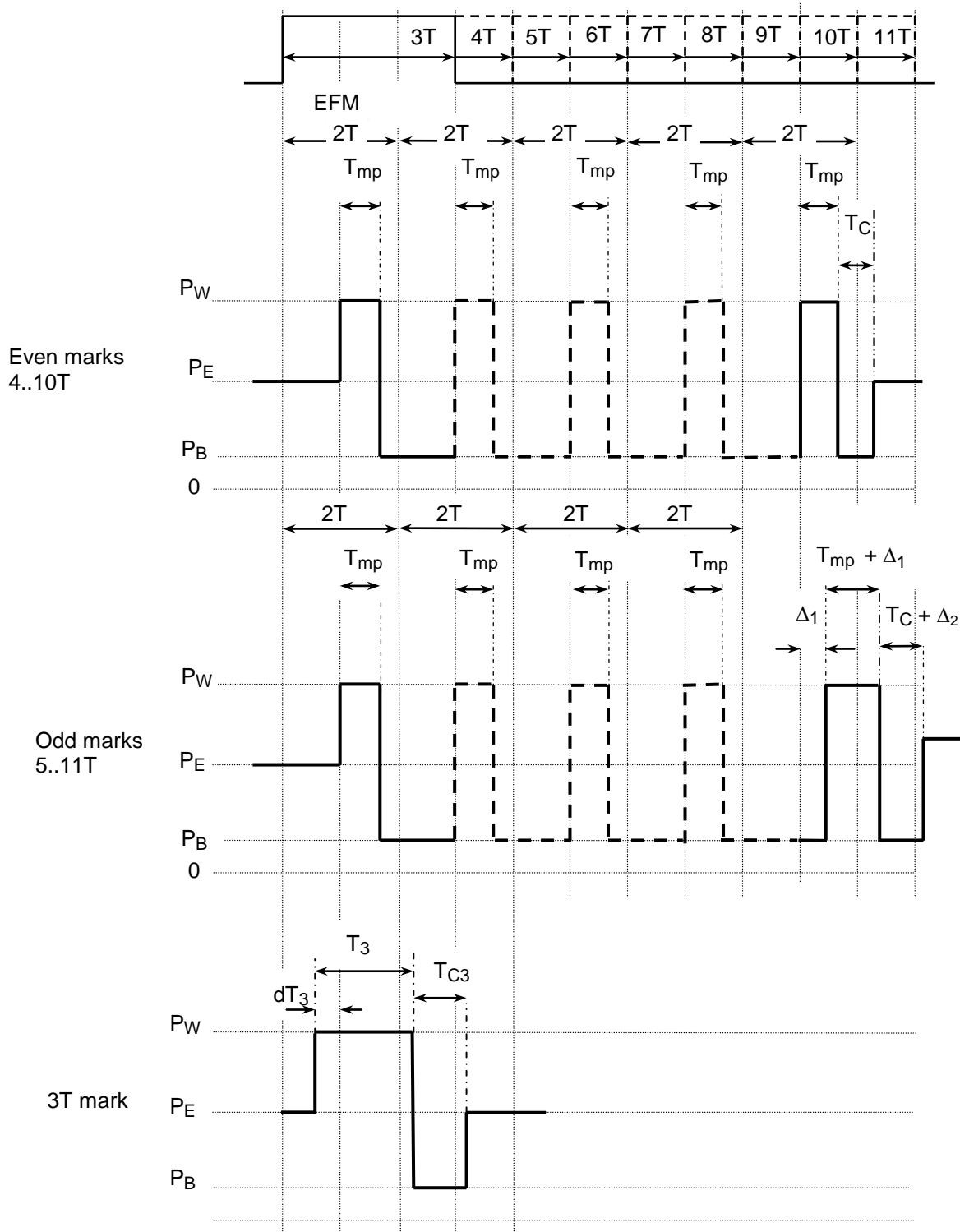

Figure 2-2: US24 '2T' Write-strategy, divided into 3T, odd and even mark-lengths

2.1.3.1.3 '2T' Write-strategy parameter range for US24 discs

The range of each '2T' Write-strategy parameter is specified in Table 2-1:

Parameter:	Description:	Range at LTS:	Range at HTS:
T_{mp}	Multi-pulse length	7.23 ns, fixed ($\equiv 3T/4$ at HTS)	
dT_3	3T pulse offset	-0.5 .. 0.5T	-0.5 .. 0.5T
T_3	3T pulse length	0.125 .. 1T	1 .. 2.5T
T_{C3}	3T cooling gap	1 .. 2.5T	0.25 .. 1T
T_C	Cooling gap for even mark	0.25 .. 1.5T	0 .. 1T
Δ_1	Odd mark stretching of 2 nd last gap and last pulse	0 .. 0.5T	0 .. 0.5T
Δ_2	Odd mark cooling gap extension	0.25 .. 1T	0 .. 0.5T

(Last cooling gap of $I_{5,7,9,11}$ mark is $T_C + \Delta_2$)

Table 2-1 '2T' Write-strategy parameter ranges

Rise and fall times of all signal transitions (from 10% to 90% of step size) shall be ≤ 1.4 ns. Signal overshoots shall be $\leq 10\%$ of the step size.

2.1.3.2 US32 media testing

For the US32 disc type, during the recordings necessary for disc measurements, using the "recorder optical pick-up (3)" specified above, the laser power is modulated according to a '2T' write strategy: this '2T' Write-strategy is applied between LTS (8x) and HTS (32x) and described in chapter 2.1.3.2.2.

2.1.3.2.1 US32 media testing with '1T' Write-strategy

For US32 discs media testing with '1T' Write-strategy is not applicable.

2.1.3.2.2 US32 media testing with '2T' Write-strategy

The US32 '2T' Write-strategy for media testing differs slightly from the US24 '2T' write strategy. The US32 '2T' Write-strategy is also divided into even and odd mark lengths and a separately specified 3T mark length (see Figure 2-3).

Each even mark I_n ($n = 4, 6, 8$ and 10) is recorded by applying a **Write Pulse Train (WPT)** consisting of $n/2$ pulses. The first pulse of each even I_n WPT starts dT_{top} before the clock edge at $1T$ after the start of the EFM signal and has a length of T_{top} . All remaining pulses of the WPT start at an even clock edge and have a length of T_{mp} and repeat every $2T$. The WPT is ended by a cooling gap with a length of T_C .

Each odd mark is recorded by applying $(n-1)/2$ pulses. The first pulse of each $I_{5,7,9,11}$ WPT starts dT_{top} before the clock edge at $1T$ after the start of the EFM signal and has a length of T_{top} . All remaining pulses but the last start at an even clock edge and have a length of T_{mp} , and repeat every $2T$. The last pulse has a length of $T_{mp} + \Delta_1$. The gap before the last pulse also has a length extension of Δ_1 . The WPT is ended by a cooling gap with a length of $T_C + \Delta_2$.

The I_3 mark is recorded by applying 1 pulse. This pulse has a length of T_3 . dT_3 is the time difference between the start of a T_3 pulse and the start of an $I_4 .. I_{11}$ WPT. The length of the cooling gap after the 3T pulse is T_{C3} . Negative values of dT_3 are leading as indicated in Figure 2-3. The power level during any write pulse is called the write level (P_W). The power

CD-RW System Description

level after each pulse within the WPT is called the bias level (P_B). The power level between each I_n WPT is called the erase level (P_E).

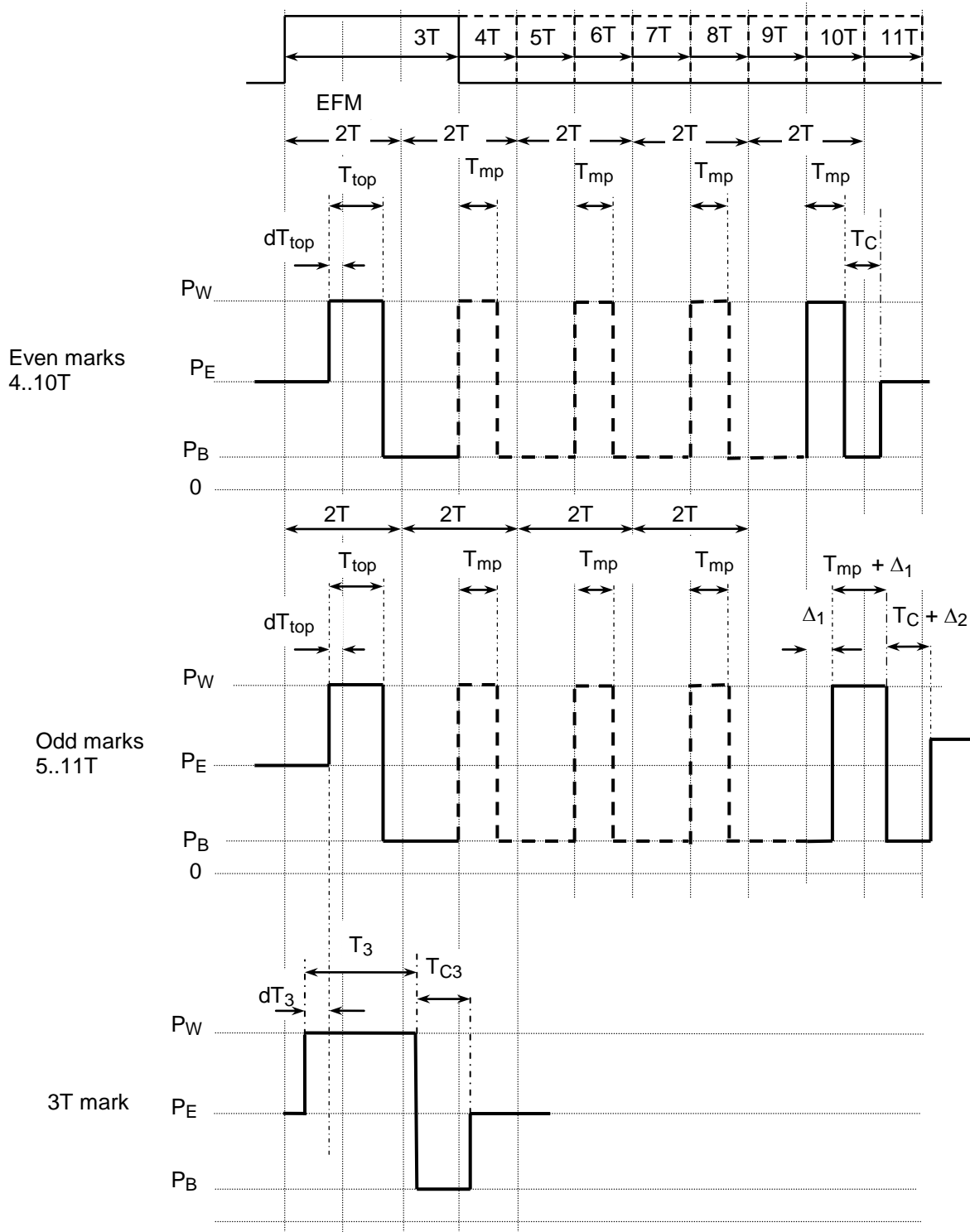

Figure 2-3: US32 '2T' Write-strategy divided into 3T, odd and even mark-lengths

2.1.3.2.3 '2T' Write-strategy parameter range for US32 discs

The range of each '2T' Write-strategy parameter is specified in Table 2-1:

Parameter:	Description:	Range at LTS:	Range at HTS:
T_{top}	Odd and Even mark first pulse length	7.23 ns, fixed ($\equiv 1T$ at HTS)	
T_{mp}	Multi-pulse length	5.42 ns, fixed ($\equiv 3T/4$ at HTS)	
dT_3	3T pulse offset	-0.5 .. 0.5T	-0.5 .. 0.5T
T_3	3T pulse length	0.125 .. 1T	1 .. 2.5T
T_{C3}	3T cooling gap	1 .. 2.5T	0.25 .. 1T
T_C	Cooling gap for even mark	0.25 .. 2T	0 .. 1.25T
Δ_1	Odd mark stretching of 2 nd last gap and last pulse	0 .. 0.5T	0 .. 0.5T
Δ_2	Odd mark cooling gap extension	0.25 .. 1T	0 .. 0.5T

(Last cooling gap of I_{5,7,9,11} mark is $T_C + \Delta_2$)

($T_{top} = dT_{top} + T_{mp}$)

Table 2-2 '2T' Write-strategy parameter ranges

Rise and fall times of all signal transitions (from 10% to 90% of step size) shall be ≤ 1.4 ns. Signal overshoots shall be $\leq 10\%$ of the step size.

2.2 The unrecorded disc

CD-RW System Description

Chapter 2 Disc Specification

- The unrecorded CD-RW Ultra Speed disc fulfils the requirements as written in the DISC SPECIFICATION of the Red Book, **except for** the items mentioned in this chapter 2.2.
- The paragraphs mentioned in this chapter 2.2 **replace** the paragraphs with the same numbering of the Red Book.

characteristic to be specified	requirement	remarks
2 outer diameter:		See chapter 1.4.1 Definitions.
2.5.1 Disc unbalance U_d for 12 cm disc	$< 2.5 \text{ g}\cdot\text{mm}$	Corresponding Unbalance Force: $F_U < 0.01 \text{ N}$ at $f_{\text{rot}} = 10 \text{ Hz}$
2.5.2 Disc unbalance U_d for 8 cm disc	$< 1 \text{ g}\cdot\text{mm}$	Corresponding Unbalance Force: $F_U < 0.004 \text{ N}$ at $f_{\text{rot}} = 10 \text{ Hz}$
2.6 Outer rim height (ORH) at read-out side	$\text{ORH} + 0.7 * (t_{\text{sub}} - 1.2) \leq 0.10 \text{ (mm)}$	See Figure 12-19 and Figure 12-20 (t_{sub} = substrate thickness at data area)
5 Clamping area		
5.4 Outer diameter of stacking ring area at read-out side	$\leq 39.5 \text{ mm}$	See Figure 12-18
5.5 Outer diameter of stacking ring area at label side	$\leq 44.0 \text{ mm}$	See Figure 12-18
8 optical requirements:		
8.6 Optical quality of the disc	wavefront distortion $< 0.05\lambda$ (RMS value)	
9 Information Area		
9.1 Start time:	Start time is 1 min, 5 sec and 65 frames (ATIP) before the start time of the Lead-in Area.	Corresponding start diameter: $45 + 0.0/-0.3 \text{ mm}$. (There is a 30 sec jump at 15 sec and 25 frames before the start time of the Lead-in Area, see chapter 4)
9.2 Max outer diameter:	118 mm (78 mm)	(for the 8 cm CD-single)
14 Sensitive layer		
14.1 Polarity of modulation:	High to Low	In the Information Area
14.2 CNR for periodic effects in the range from 200-720 kHz:	$\geq 47 \text{ dB}$	BW = 10 kHz
15 Radial tracking signals		
15.1 Normalized Push Pull Ratio	0.5 - 1.3	See attachment 0
15.2 Max. variation of Push Pull amplitude	$\pm 15 \%$	$\Delta\text{PP} / \langle\text{PP}\rangle$ Over one disc
15.3 Radial noise	See Red Book: 15.2	
15.4 Radial Contrast	$\text{RC}_b > +0.05$	

characteristic to be specified	requirement	remarks
16 Tangential tracking signals		
16.1 Locking frequency for the groove wobble	22.05 kHz	
16.2 Normalized wobble signal	0.035 - 0.060	See attachment 0
16.3 CNR of wobble	> 35 dB	BW = 1 kHz
17 Time encoding		
17.1 Wobble modulation:	ATIP	See chapter 4
17.2 ATER:	< 10 %	Averaged over any 10 seconds
17.3 Max number of successive erroneous ATIP frames:	3 frames	
18 Recording conditions		
18.1 General recording strategy:	- In groove - laser modulation - write, erase and direct overwrite	Tests shall be performed with Random EFM (see chapter 1.4)
18.2.1 Optimum write power of a disc:	P_{WO} : Write conditions where the following conditions are met: <ul style="list-style-type: none"> • lowest jitters and best effect lengths written at DOW 10 • jitters and effect lengths at DOW 0 and DOW 1000 within specification • modulation at DOW 0 within specification 	For US24 media, OPC parameters in ATIP (γ, ρ, P_{ind}) should be such that the OPC result is as close to P_{WO} as possible (1T Write-strategy only). See also attachment 13.3. Indicative values for P_{WO} are given in ATIP, see chapter 4.4.
18.2.2 Optimum erase power of a disc:	P_{EO} , erase power where the following condition is met: <ul style="list-style-type: none"> • lowest jitters and best effect lengths written at DOW 10 and P_{WO} 	For US24 media, ϵ in ATIP should correspond to P_{EO}/P_{WO} . ('1T' write-strategy only) See attachment 13.3. Indicative values for P_{EO} and P_{WO} are given in ATIP, see chapter 4.4.
18.2.3 Optimum bias power of a disc:	$P_{BO} \leq 1.0$ mW	
18.2.4 Optimum CW-Erase power of a disc:	$P_{ECW} \leq 1.15 * P_{EO}$	See attachment 13.1.4

CD-RW System Description

Chapter 2 Disc Specification

characteristic to be specified	requirement	remarks
18.3a Optimum write and erase power when '1T' Write-strategy is applied (for US24 media only)	$40 \leq P_{WO} \leq 55 \text{ mW}$ $7 \leq P_{EO} \leq 15 \text{ mW}$	P_{WO} and P_{EO} in central spot, for all defined recording speeds(see Figure 2-1, Figure 2-2 and Figure 2-3)
18.3b Optimum write and erase power when US24 '2T' Write-strategy is applied:	$30 \leq P_{WO} \leq 45 \text{ mW}$ $7 \leq P_{EO} \leq 15 \text{ mW}$	For US24 disc only
18.3c Optimum write and erase power when US32 '2T' Write-strategy is applied:	$35 \leq P_{WO} \leq 50 \text{ mW}$ $6 \leq P_{EO} \leq 13 \text{ mW}$	For US32 discs only
18.4a Write power window of a disc: for $0.90 \cdot P_{WO} < P_W < 1.1 \cdot P_{WO}$ and P_{EO} , P_{WO} as indicated in ATIP:	disc must be recordable within specifications	For the first 10 DOW cycles
18.4b Number of DOW cycles at $P_W = P_{WO}$	> 1000	P_{WO} shall be determined with an accuracy better than $\pm 5\%$. The recorded disc must be within all specifications given in chapter 2.3
18.5 Maximum variation of P_{WO} Maximum variation of P_{EO}	$\pm 0.05 \cdot P_{WO}$ $\pm 0.05 \cdot P_{EO}$	Over one disc at a fixed CLV Over one disc at a fixed CLV
18.6 Wavelength of write spot:	$780 < \lambda < 792 \text{ nm}$ at $T_{\text{ambient}} = 23 \text{ }^\circ\text{C}$	
19 Local defects	See Red Book: 15.3 and attachment 7.	
20 Environment (operating conditions during recording)	Disc must be recordable in all combinations given in Figure 12-4	See attachment 13.4
20.1 Temperature range	$T = -5 \text{ to } +55 \text{ }^\circ\text{C}$	
20.2 Absolute humidity	$0.5 \text{ to } 30 \text{ g/m}^3$	
20.3 Relative humidity	5% to 95%	

2.3 The recorded disc

- The recorded CD-RW disc fulfils all requirements as written in the chapter: "DISC SPECIFICATION" of the Red Book, unless otherwise stated in this chapter.
- The data on the disc has been recorded at a Usable CLV Recording Speed (see chapter 4.4.4).
- All parameters are specified for play-back at 1x nominal CD speed, according to the Red Book. Measurements could be performed at other speeds with appropriate scaling of the results.

characteristic to be specified		requirement	remarks
8.4	Reflection and double pass substrate transmission	$0.15 < R_{top} < 0.25$	
8.5	Max. variation of reflection	$\pm 10\%$	$\Delta R_{top} / \langle R_{top} \rangle$ Over one disc at DOW(0)
9.3	Starting diameter of Lead-in Area	46 +0.0/-0.2 mm	Corresponding start time indicated in ATIP during the Lead-in area (see chapter 4.4)
14	HF signal		See attachment 13.2
14.1	HF Modulation		Under formal test conditions: recorded using recorder pick-up (3), readout with read only pick-up (1)
14.1.1	Modulation amplitude $m_{11} = I_{11}/I_{top}$	$0.55 < m_{11} < 0.70$	
14.1.2	I_3/I_{11} ratio	$0.4 < I_3/I_{11} < 0.6$	
14.1.3	Max. variation of modulation amplitude	$\pm 10\%$	
14.1.4	change of modulation amplitude after DOW (1000)	$< \pm 0.10 * m_{11}$	$\Delta m_{11} / \langle m_{11} \rangle$ at DOW(0) Over one disc at a fixed CLV
14.5	Recorded time errors	no C2 uncorrectable errors at play back with 2.5 kHz PLL band width	
14.6	Single frequency time errors:	The spectral components of the time errors should be below the values given in Figure 12-5.	For spectral components ≤ 4 kHz
14.7	Jitter and effect length	see Red Book	
14.9	asymmetry	$-15 \leq asym \leq +10 \%$	Asymmetry definition according to Red Book, measured by read-only pick-up (1)

CD-RW System Description

characteristic to be specified	requirement	remarks
15 Radial tracking signals		
15.1 Push Pull magnitude	0.08 - 0.12	See attachment 0
15.4.1 Radial Contrast	$0.3 < RC_a < 0.6$	Over all discs
15.4.2 Max. variation of Radial Contrast	$\pm 20 \%$	$\Delta RC_a / \langle RC_a \rangle$ Over one disc
17 Tangential tracking signals		
17.1 Locking frequency for the groove wobble	22.05 kHz	
17.2 CNR of wobble	$> 26 \text{ dB}$	BW = 1 kHz
18 Read conditions		at 2x nominal CD speed
18.1 Power of read spot	$< 1.0 \text{ mW}$	CW, in central spot
18.2 Read stability	$> 10^6$ times successively read from a single track, the disc must remain within specification.	For $T = 70 \text{ }^\circ\text{C}$ and $P_{\text{read}} = 1 \text{ mW}$ (see attachment 13.1.3)
18.3 Wavelength of read spot	$770 < \lambda < 800 \text{ nm}$	

2.4 The recorded disc specifications for read-out at shorter wavelengths (optional)

The following requirements should be fulfilled to enable CD-RW discs to be played back at a typical laser wavelength of 650 nm.

characteristic to be specified		requirement	remarks
1	Reference measurement conditions		
1.1	Numerical Aperture	$NA = 0.38 \pm 0.01$	
1.2	Laser Diode wavelength	$\lambda = 650 \pm 5 \text{ nm}$	
1.3	Pupil rim intensities		
1.3.1	Tangential	> 0.80	
1.3.2	Radial	> 0.80	
1.4	Polarization	circular	Polarizing Beam Splitter shall be used.
1.5	Min. optical quality	$33 \text{ m}\lambda \text{ RMS}$	Optical wave front distortion in focus.
1.6	Relative Intensity Noise (RIN) of Laser Diode	$< -134 \text{ dB / Hz}$	$RIN = 10 * \log\left(\frac{AC \text{ power density / Hz}}{DC \text{ power}}\right)$
2	Sensitivity to read-out conditions		
2.1	Read stability @ $P_{\text{read}} = 0.5 \text{ mW}$	$> 10^6$ times	After 10^6 successive reads from a single track, at 2x nominal CD speed, the disc must remain within specifications.
2.2	Operating wavelength of read-out spot	640 - 670 nm	Within this range disc must be within specifications.
3	Reflectivity		
3.1	R_{top}	$0.20 < R_{\text{top}} < 0.40$	
4	HF signals		
4.1	Reflection-modulation product	$0.12 < R_{\text{top}} * I_{11}/I_{\text{top}} < 0.30$	
4.2	I_3/I_{11} ratio	$0.4 < I_3/I_{11} < 0.7$	Before equalization.
4.3	Asymmetry	$-0.15 < \text{asym} < +0.10$	Before equalization.
4.4	Data to clock jitter	$< 10\%$ of EFM clock period	
5	Radial signals		
5.1	Radial Differential signal magnitude	$RD < 1.0$	For definitions, see paragraph 1.4.4
5.2	Radial Contrast signal		
5.2.1	Radial Contrast	$0.40 < RC_a < 0.80$	
5.2.2	Sign of RC signal	$I_{ga} < I_{la}$	

This page is intentionally left blank

3. Requirements & recommendations for CD-recorders

3.1 Use of Disc Application Code, RID code and SCMS

- All CD-recorders shall read the Disc Application Code and act accordingly to this.
(see chapter 4.4.1.3)
- Consumer CD-recorders are only allowed to write on discs for unrestricted use.
(see chapter 4.4.1.3)
- Consumer CD-recorders shall write their Recorder IDentification (RID) code in subcode Q-channel mode 3.
(see chapter 5.6.3.2)
- Consumer CD-recorders shall apply the Serial Copy Management System (SCMS).
(see attachment 13.9 and chapter 5.6.3.1)
- Professional CD-recorders, able to write the CD-ROM and/or the CD-i Format, shall write their Recorder IDentification (RID) code in the main channel of the Table Of Contents Items in the PMA.
(see chapter 5.4.5)
- All CD-recorders (Consumer as well as Professional) shall write the Disc Identification Item in subcode Q-channel in the PMA (see chapter 5.4.1 and 5.4.3).

3.2 Use of Skip features in audio discs

- It is recommended that all CD-recorders, able to write the CD-DA Format, react properly to all Time Intervals and Tracks that should be skipped as a result of the complete skip information in the PMA.
(see chapter 5.4.3)
- When an audio disc is finalized, it is recommended that all CD-recorders copy the skip information from the PMA to the TOC in the Lead-in Area. The number of "Skip Track" and "Skip Time Interval" Items that can be recorded in the Lead-in Area is limited to maximally 40 Time Intervals and 21 Tracks.
(see chapter 5.5)

3.3 Use of Mode 6 for Disc Identification

- All CD-recorders shall copy the "Disc Identification" item as recorded in the PMA with ADR = 2 (see Chapter 5.4.3) in the first Lead-in Area with ADR = 6 (see Chapter 5.5)

This page is intentionally left blank

4. Pre-groove modulation, ATIP

By means of the groove wobble frequency (the carrier frequency), the CD-RW disc contains motor control information and by means of ATIP (Absolute Time In Pre-groove, modulating the carrier frequency), the CD-RW disc contains time-code information.

The ATIP time-code increases monotonically throughout the disc, except between the PCA Test Area and the PCA Count Area, where the time-code makes a jump of 30 seconds (see Figure 12-6).

4.1 General parameters

Disc : Radial track wobble
 Carrier frequency : 22.05 kHz
 Analog modulation : FM
 Digital modulation : Biphase-Mark
 Synchronization : Biphase violation
 Data bit-rate : 3150 Bits/Sec
 Frame length : 42 bits (see Figure 4-1)
 Frame frequency : 75 Hz
 Data contents : 3 Bytes (Min Sec Frames, 1 Byte each)
 Error protection : 14 bits CRC

4.2 FM modulation

Carrier frequency : 22.05 kHz
 Deviation : 1 kHz ± 10 %
 Oscillator output : Sinewave
 Oscillator THD : < - 40 dB

4.3 Frame format

The format of an ATIP frame is defined in Figure 4-1:

Nr of bits	4	8	8	8	14
Bit position	1234	56789012	34567890	12345678	90123456789012
Data	Sync	Minutes	Seconds	Frames	CRC remainder

Figure 4-1 Definition of the bits and fields in an ATIP frame

4.3.1 Frame synchronization

For synchronization of the ATIP data the Biphase-Mark code rules are violated. The synchronization pattern used is 11101000 if the preceding cell = 0, or 00010111 if the preceding cell = 1.

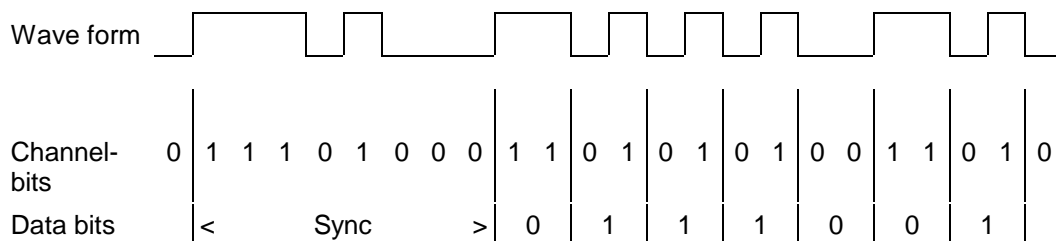

Figure 4-2 Example 1 of the synchronization of the ATIP frames

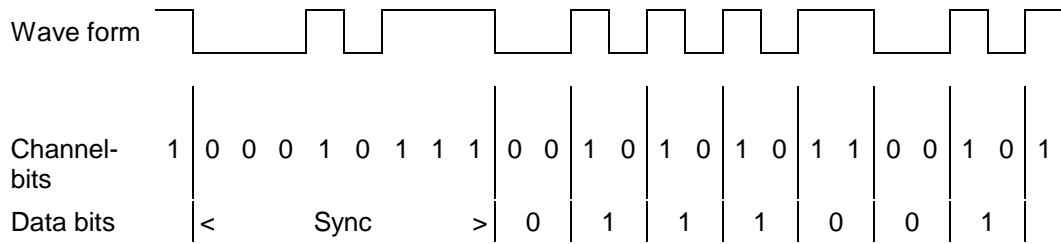

Figure 4-3 Example 2 of the synchronization of the ATIP frames

4.4 Data format

The format of the ATIP time information is identical to the time encoding in Subcode-Q and in the CD-ROM header. The ATIP time information is represented in Binary Coded Decimal (BCD) with the most significant bit first as follows (see Figure 4-1):

- Minutes : 2 digits BCD (M1..M4 and M5..M8), MSBit (M1) on position 5
- Seconds : 2 digits BCD (S1..S4 and S5..S8), MSBit (S1) on position 13
- Frames : 2 digits BCD (F1..F4 and F5..F8), MSBit (F1) on position 21

In addition to the normal time-code, in the Lead-in Area¹ extra CD-RW information is encoded in the ATIP Minutes, Seconds and Frames bytes. This extra information is identified by specific combinations of the MSB's of the Minutes, Seconds and Frames bytes (bit 5, 13 and 21) as defined in Figure 4-4.

In the Program Area, the Lead-out Area, the PCA and the PMA only the normal time-code shall be encoded.

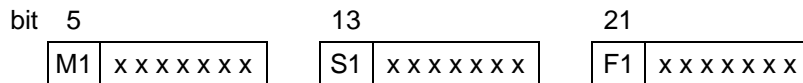

M1,S1,F1 = 000 or 100 : Time-code in Information area (see Figure 12-6)

- = 101 : Special Information 1: write power at 1T Test Speed, 1T Test Speed, application code, disc type identification (see chapter 4.4.1) and disc sub-type
 - = 110 : Special Information 2: start time of Lead-in Area (see chapter 4.4.2)
 - = 111 : Special Information 3: last possible start time of Lead-out Area (see chapter 4.4.3)
- Note: last possible start-time of Lead-out Area ≤ 79:59:74*
- = 001 : Additional Information 1: speed range for '1T' Write-strategy, OPC parameters and erase power at 1T Test Speed with '1T' Write Strategy (see chapter 4.4.4)
 - = 010 : Additional Information 2: speed range for '2T' Write-strategy (see chapter 4.4.5)
 - = 011 : Additional Information 3: Media Identification code (see chapter 4.4.6)

Figure 4-4 Identification of the extra information in the Lead-in Area

¹ In the context of the ATIP specifications, the term "Lead-in Area" has to be interpreted as the disc area between diameters 46 and 50 mm (so not the Lead-in Areas of 2nd or higher Sessions on a Multisession disc).

The sequence of successive ATIP frames in the Lead-in Area of a CD-RW disc must be as indicated in Figure 4-5:

- One ATIP frame encoded with Special or Additional Information, followed by nine ATIP frames encoded with time-code information.
- Encoding of Special Information 1, 2 and 3 and Additional Information 1, 2 and 3 is mandatory.
- All the encoded frames with Special and Additional Information must be used cyclic and must be successively repeated.
- The first frame with Special Information 1 shall replace the timecode = Start time of Lead-in Area. (In future, offsets between Start time of Lead-in Area and the first Special Information 1 can be introduced. Drives according to this version of this document should ignore such offsets.)

frame number	frame contents
:	normal time-code
N-1	
N	Special Information 1
N+1	
:	normal time-code
N+9	
N+10	Special Information 2
N+11	
:	normal time-code
N+19	
N+20	Special Information 3
N+21	
:	normal time-code
N+29	
N+30	Additional Information 1
N+31	
:	normal time-code
N+39	
N+40	Additional Information 2
N+41	
:	normal time-code
N+49	
N+50	Additional Information 3
N+51	
:	normal time-code
N+60	Special Information 1
N+61	
:	normal time-code

Figure 4-5 Encoding of ATIP frames in the Lead-in Area

CD-RW System Description

4.4.1 Special Information 1 : M1,S1,F1 = 101

These 3 groups of 7 bits identify the disc type and specify several disc parameters (see Figure 4-6).

Figure 4-6 Combinations and definitions of the bits in Special Information 1

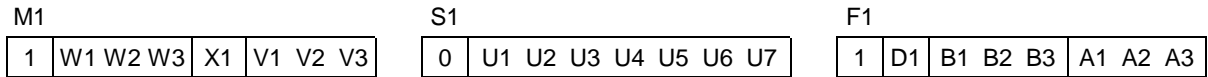

W1..W3 : Indicative Target Writing Power at 1T Test Speed ($P_{ind,1T}$)

X1 : Reserved and set to zero

V1..V3 : 1T Test Speed

U1..U7 : Disc Application Code

D1 : Disc type

B1..B3 : Disc sub-type

A1..A3 : Presence of Additional Information

4.4.1.1 Indicative Target Writing Power at 1T Test Speed: W1..W3

These values are only applicable for US24 discs. US32 discs shall have W1..W3 = 000.

W1..W3 specify an indicative value $P_{ind,1T}$ for $P_{target,1T}$ (see attachment 13.3). This $P_{ind,1T}$ value is given for a laser wavelength of 786 nm and $T = 23\text{ }^{\circ}\text{C}$ at the 1T Test Speed as specified in V1..V3 (see chapter 4.4.1.2).

The actual optimum $P_{target,1T}$ depends on the recording speed and on parameters of the optical recorder pickup unit. Therefore the encoded value $P_{ind,1T}$ can only be used as a starting value for the determination of the optimum value of $P_{target,1T}$ by an Optimum Power Control procedure, as described in attachment 13.3.

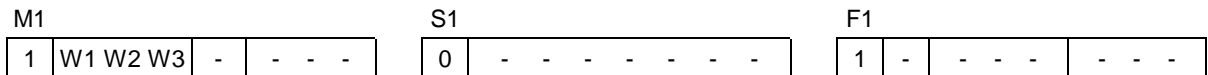

W1 .. W3 for US24 (B1 .. B3 = 010)	W1 .. W3 for US32 (B1 .. B3 = 011)
000 : $P_{ind,1T} = 35\text{ mW}$	000: Default for US32 discs
001: $P_{ind,1T} = 36\text{ mW}$	001: Reserved
010: $P_{ind,1T} = 38\text{ mW}$	010: Reserved
011: $P_{ind,1T} = 39\text{ mW}$	011: Reserved
100: $P_{ind,1T} = 41\text{ mW}$	100: Reserved
101: $P_{ind,1T} = 42\text{ mW}$	101: Reserved
110: $P_{ind,1T} = 44\text{ mW}$	110: Reserved
111: $P_{ind,1T} = 45\text{ mW}$	111: Reserved

4.4.1.2 1T Test Speed: V1..V3

These values are only applicable for US24 discs. US32 discs shall have V1..V3 = 000.
The nominal CLV (Constant Linear Velocity) speed of the CD system is between 1.2 and 1.4 m/sec. The recording parameters of the media are defined at different recording speeds: at the Lowest Test Speed, at the Highest Test Speed, and at the 1T Test Speed given by V1..V3.



V1 .. V3 for US24 (B1 .. B3 = 010)	V1 .. V3 for US32 (B1 .. B3 = 011)
000: Reserved	000: Default for US32 discs
001: Reserved	001: Reserved
010: Reserved	010: Reserved
011: Reserved	011: Reserved
100: Reserved	100: Reserved
101: Reserved	101: Reserved
110: 1T Test Speed = 16x nominal CD Speed	110: Reserved
111: Reserved	111: Reserved

4.4.1.3 Disc Application Code: U1..U7

This code distinguishes between discs used for different applications. The two main application categories are: "Discs for unrestricted use", and "Discs for restricted use". Within the category "Discs for restricted use", an additional encoding may be used for the identification of Special Disc Applications.

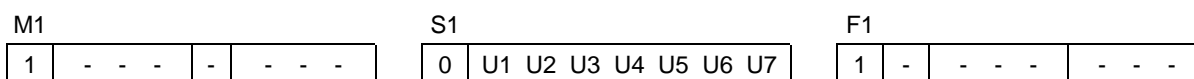

- U1 = 0 : disc for restricted use
 - U2..U7 = 000000 : Reserved for General purpose use
 - U2..U7 = others : Reserved

- U1 = 1
 - U2..U7 = 000000 : Disc for unrestricted use
 - U2..U7 = others : Reserved

Discs for **restricted use** are meant to be used in Professional CD-recorders only. Within this category the General Purpose discs can be used for any application. Special Purpose discs, carrying a registered Identification Code, are meant for that registered application only. Registration of the Identification Codes can be requested from Royal Philips Electronics (for detailed address information see: "Conditions of publication" in this document).

Discs for **unrestricted use** may be used in Consumer CD-recorders and in Professional CD-recorders.

CD-RW System Description

4.4.1.4 Disc type identification: D1

This single bit identifies the disc type.

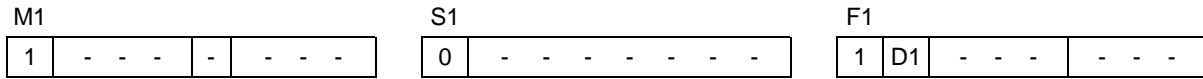

- D1 = 1 : ReWritable disc according to this specification
 = 0 : Reserved (for CD-R discs according to the Orange Book part II)

4.4.1.5 Disc sub-type identification: B1..B3

These 3 bits are reserved to specify a sub-class within the ReWritable disc types.

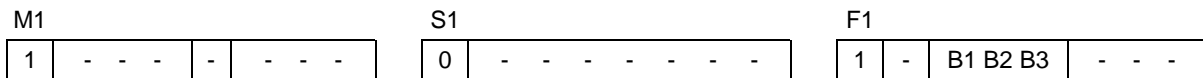

- B1..B3 = 000 : Reserved (for CD-RW 1x-4x discs according to Orange Book, part III, volume 1)
 = 001 : Reserved (for CD-RW High-Speed disc according to Orange Book, part III, volume 2)
 = 010 : CD-RW Ultra Speed discs **8x-24x** (US24) according to this specification
 = 011 : CD-RW Ultra Speed discs **8x-32x** (US32) according to this specification
 = others : Reserved

CD-RW recorders can be designed in compliance with several specifications, which can be identified by different Disc type / sub-type (D1 / B1..B3) settings. In future new settings may be defined. To prevent possible compatibility problems between such future discs and existing recorders, the following rule should be applied:

If a disc is detected of which the Disc type / sub-type settings are unknown to the recorder, it is recommended that writing to such a disc by that recorder is prohibited.

4.4.1.6 Additional Information 1, 2 or 3 present: A1..A3

Each of these three bits indicates the presence of one of the Additional Information 1, 2 or 3 in ATIP in the Lead-in area:

- A1 indicates the presence of Additional Information 1 (0 = not present, 1 = present)
 A2 indicates the presence of Additional Information 2 (0 = not present, 1 = present)
 A3 indicates the presence of Additional Information 3 (0 = not present, 1 = present)

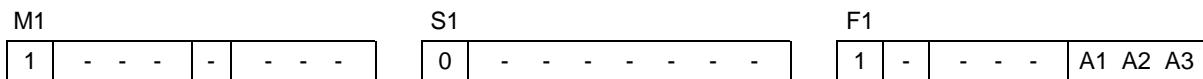

- A1..A3 = 111 : Additional Information 1 encoded in Lead-in
 Additional Information 2 encoded in Lead-in
 Additional Information 3 encoded in Lead-in
 = others : Reserved

4.4.2 Special Information 2 : M1,S1,F1 = 110

This code specifies the start position of the Lead-in Area in ATIP time-code. On the disc, the MSBit of each time-code byte is replaced by the value of M1, S1 or F1 as specified in Figure 4-7.

At decoding the MSBit of each time-code byte has to be interpreted in the following way:

- M1 to be replaced by M1 = 1,
- S1 to be replaced by S1 = 0,
- F1 to be replaced by F1 = 0.

Figure 4-7 Combinations and definitions of the bits in Special Information 2

M1	S1	F1
1 M2 M3 M4 M5 M6 M7 M8	1 S2 S3 S4 S5 S6 S7 S8	0 F2 F3 F4 F5 F6 F7 F8

M1,M2..M8 S1,S2..S7 F1,F2..F7 : Minutes, Seconds, Frames

Example = 1001 0111 0100 1001 0000 0000
= 97:49:00 (example of decoded start time of Lead-in Area)

4.4.3 Special Information 3 : M1,S1,F1 = 111

This code specifies the last possible start position of the Lead-out Area in ATIP time-code. On the disc, the MSBit of each time-code byte is replaced by the value of M1, S1 or F1 as specified in Figure 4-8.

At decoding the MSBit of each time-code byte has to be interpreted in the following way:

- M1 to be replaced by M1 = 0,
- S1 to be replaced by S1 = 0,
- F1 to be replaced by F1 = 0.

Figure 4-8 Combinations and definitions of the bits in Special Information 3

M1	S1	F1
1 M2 M3 M4 M5 M6 M7 M8	1 S2 S3 S4 S5 S6 S7 S8	1 F2 F3 F4 F5 F6 F7 F8

M1,M2..M7 S1,S2..S7 F1,F2..F7 : Minutes, Seconds, Frames

Example = 0111 0000 0100 0101 0001 0101
= 70:45:15 (example of decoded last possible start time of Lead-out Area)

CD-RW System Description

4.4.4 Additional Information 1 : M1,S1,F1 = 001

These three groups of 7 bits specify recording parameters of the disc, in addition to the recording parameters specified in Special Information 1. They only relate to the use of '1T' Write-strategy, and therefore only applicable for US24x discs. For US32 discs these values shall be set to 0.

Figure 4-9 Combinations and definitions of the bits in Additional Information 1

M1				S1				F1															
0	L1	L2	L3	H1	H2	H3	H4	0	P1	P2	P3	G1	G2	G3	Y1	1	E1	E2	E3	C1	C2	C3	C4

- L1..L3 : Lowest '1T' Test Speed
- H1..H4 : Highest '1T' Test Speed
- P1..P3 : Power Multiplication Factor ρ at '1T' Test Speed, '1T' Write-strategy applied
- G1..G3 : Target γ value of the modulation/power function at '1T' Test Speed, '1T' Write-strategy applied
- Y1 : Reserved and set to zero

- E1..E3 : Recommended erase/write power ratio ε at '1T' Test Speed, '1T' Write-strategy applied
- C1..C4 : Write-strategy optimization at '1T' Test Speed, '1T' Write-strategy applied

4.4.4.1 Lowest 1T Test Speed: L1..L3

These values are only applicable for US24 discs. US32 discs shall have L1..L3 = 000
 These 3 bits specify the lowest '1T' Write-strategy Test Speed at which this medium shall fulfill all requirements as defined in chapter II.3.

M1				S1				F1															
0	L1	L2	L3	-	-	-	-	0	-	-	-	-	1	-	-	-	-	-	-	-	-	-	-

L1 .. L3 for US24 (B1 .. B3 = 010)	L1 .. L3 for US32 (B1 .. B3 = 011)
000: Reserved	000: Default for US32 discs
001: Reserved	001: Reserved
010: Reserved	010: Reserved
011: Reserved	011: Reserved
100: Reserved	100: Reserved
101: Reserved	101: Reserved
110: 1T Test Speed = 16x nominal CD Speed	110: Reserved
111: Reserved	111: Reserved

4.4.4.2 Highest 1T Test Speed: H1..H4

These values are only applicable for US24 discs. US32 discs shall have H1..H4 = 0000
These 3 bits specify the highest '1T' Write-strategy Test Speed at which this medium shall fulfill all requirements as defined in chapter II.3.

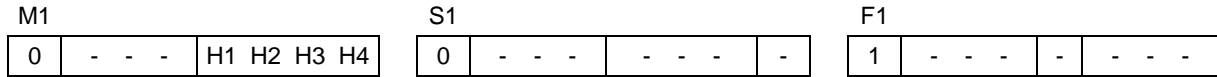

H1 .. H4 for US24 (B1 .. B3 = 010)	H1 .. H4 for US32 (B1 .. B3 = 011)
0110: Highest 1T Test Speed = 16x nominal CD Speed	0000: Default for US32 discs
All other values: reserved	All other values: reserved

4.4.4.3 Power Multiplication Factor ρ at 1T Test Speed: P1..P3

These values are only applicable for US24 discs. US32 discs shall have P1..P3 = 000
P1..P3 specify a multiplication factor ρ_{1T} with which the actual optimum $P_{target,1T}$, determined by the OPC procedure at 1T Test Speed, has to be multiplied to get the optimum write power $P_{WO,1T}$ (see attachment 13.3). The value of this factor is given for a laser wavelength of 786 nm and $T = 23^{\circ}C$ at the Reference Speed.

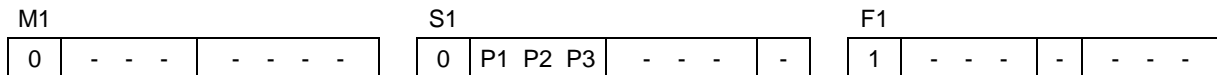

P1 .. P3 for US24 (B1 .. B3 = 010)	P1 .. P3 for US32 (B1 .. B3 = 011)
000: $\rho_{1T} = 1.10$	000: Default for US32 discs
001: $\rho_{1T} = 1.18$	001: Reserved
010: $\rho_{1T} = 1.26$	010: Reserved
011: $\rho_{1T} = 1.35$	011: Reserved
100: $\rho_{1T} = 1.44$	100: Reserved
101: $\rho_{1T} = 1.54$	101: Reserved
110: $\rho_{1T} = 1.64$	110: Reserved
111: $\rho_{1T} = 1.75$	111: Reserved

CD-RW System Description

4.4.4.4 Target γ value of the Modulation/Power function at 1T Test Speed: G1..G3

These values are only applicable for US24 discs. US32 discs shall have G1..G3 = 000
G1..G3 specify the γ value for which the OPC procedure has to determine the actual optimum $P_{\text{target},X}$ (see attachment 13.3). Only one γ value is given, which is to be used at all speeds.

M1	S1	F1
0 - - - - - - -	0 - - - G1 G2 G3 -	1 - - - - - - -

G1 .. G3 for US24 (B1 .. B3 = 010)	G1 .. G3 for US32 (B1 .. B3 = 011)
000: $\gamma_{\text{target}, 1T} = 0.50$	000: Default for US32 discs
001: $\gamma_{\text{target}, 1T} = 0.60$	001: Reserved
010: $\gamma_{\text{target}, 1T} = 0.75$	010: Reserved
011: $\gamma_{\text{target}, 1T} = 0.90$	011: Reserved
100: $\gamma_{\text{target}, 1T} = 1.10$	100: Reserved
101: $\gamma_{\text{target}, 1T} = 1.35$	101: Reserved
110: $\gamma_{\text{target}, 1T} = 1.65$	110: Reserved
111: $\gamma_{\text{target}, 1T} = 2.00$	111: Reserved

4.4.4.5 Recommended erase/write power ratio ε at 1T Test Speed: E1..E3

These values are only applicable for US24 discs. US32 discs shall have E1..E3 = 000
E1..E3 specify the recommended erase/write power ratio $\varepsilon_{1T} = P_{EO,1T} / P_{WO,1T}$ (see attachment 13.3). The value of this ratio is given for a laser wavelength of 786 nm and $T = 23^\circ\text{C}$ at the Reference Speed.

M1	S1	F1
0 - - - - - - -	0 - - - - - - -	1 E1 E2 E3 - - - -

E1 .. E3 for US24 (B1 .. B3 = 010)	E1 .. E3 for US32 (B1 .. B3 = 011)
000: $\varepsilon_{1T} = 0.125$	000: Default for US32 discs
001: $\varepsilon_{1T} = 0.150$	001: Reserved
010: $\varepsilon_{1T} = 0.175$	010: Reserved
011: $\varepsilon_{1T} = 0.200$	011: Reserved
100: $\varepsilon_{1T} = 0.225$	100: Reserved
101: $\varepsilon_{1T} = 0.250$	101: Reserved
110: $\varepsilon_{1T} = 0.300$	110: Reserved
111: $\varepsilon_{1T} = 0.350$	111: Reserved

4.4.4.6 Write-strategy optimization for '1T' Write-strategy at 1T Test Speed

These values are only applicable for US24 discs. US32 discs shall have C1..C4 = 0000.
These bits specify the optimum Write Pulse Train for the actual medium (see chapter 2.1.3) when '1T' Write-strategy at 1T Test speed is applied.
C1,C2 specify the optimum value for dT_{top} .
C3,C4 specify the optimum value for dT_{era} .

M1				S1				F1					
0	-	-	-	0	-	-	-	1	-	-	-	C1 C2	C3 C4

C1, C2 and C3, C4 for US24 (B1 .. B3 = 010)		C1, C2 and C3, C4 for US32 (B1 .. B3 = 011)	
C1, C2 = 00: m = 0	C3, C4 = 00: n = -1	C1, C2 = 00	C3, C4 = 00
C1, C2 = 01: m = 1	C3, C4 = 01: n = 0	C1, C2 = 01: reserved	C3, C4 = 01: reserved
C1, C2 = 10: m = 2	C3, C4 = 10: n = 1	C1, C2 = 10: reserved	C3, C4 = 10: reserved
C1, C2 = 11: m = 3	C3, C4 = 11: n = 2	C1, C2 = 11: reserved	C3, C4 = 11: reserved

4.4.5 Additional Information 2 : M1,S1,F1 = 010

These three groups of 7 bits specify recording parameters of the disc, in addition to the recording parameters specified in Special Information 1. They only relate to the use of '2T' Write-strategy.

Figure 4-10 Combinations and definitions of the bits in Additional Information 2

M1				S1				F1			
0	L4 L5 L6	H5 H6 H7 H8	1	P4 P5 P6	P7 P8 P9	Y1	0	E4 E5 E6	E7 E8 E9	Z1	

- L4..L6 : Lowest '2T' Write-strategy Test Speed
- H5..H8 : Highest '2T' Write-strategy Test Speed
- P4..P6 : Optimum '2T' Write-strategy write power indication at 16x
- P7..P9 : Optimum '2T' Write-strategy write power indication at HTS
- Y1 : Reserved and set to zero

- E4..E6 : Optimum '2T' Write-strategy erase power indication at 16x
- E7..E9 : Optimum '2T' Write-strategy erase power indication at HTS
- Z1 : Reserved and set to zero

4.4.5.1 Lowest '2T' Write-strategy Test Speed L4..L6

These 3 bits specify the Lowest '2T' Write-strategy Test Speed at which this medium shall fulfill all requirements as defined in chapter II.3.

M1				S1				F1			
0	L4 L5 L6	-	-	1	-	-	-	0	-	-	-

L4 .. L6 for US24 (B1 .. B3 = 010)	L4 .. L6 for US32 (B1 .. B3 = 011)
011: Lowest 2T = 8x nominal CD Speed	011: Lowest 2T = 8x nominal CD Speed
All other values: reserved	All other values: reserved

CD-RW System Description

Chapter 4
Pre-groove modulation, ATIP

4.4.5.2 Highest '2T' Write-strategy Test Speed H5..H8

These 4 bits specify the Highest '2T' Write-strategy Test Speed at which this medium shall fulfill all requirements as defined in chapter II.3.

M1	S1	F1
0 - - - H5 H6 H7 H8	1 - - - - - - -	0 - - - - - - -

H5 .. H8 for US24 (B1 .. B3 = 010)	H5 .. H8 for US32 (B1 .. B3 = 011)
1000: Highest '2T' Write-strategy Speed = 24x	1000: Reserved
1001: Reserved	1001: Highest '2T' Write-strategy Speed = 32x
Other values: reserved	Other values: reserved

4.4.5.3 Optimum write power indication at 16x and '2T' Write-strategy

These 3 bits specify the optimum write power indication P_{WO} , applying '2T' write strategy at 16x recording speed. Optimum write power is specified in paragraph 2.2. These values are applicable for both US24 and US32 discs.

M1	S1	F1
0 - - - - - - -	1 P4 P5 P6 - - - -	0 - - - - - - -

P4 .. P6 for US24 and US32 (B1 .. B3 = 010 and 011)
000: $P_{WO, 2T}$ not specified
001: $P_{WO, 2T} = 30$ mW
010: $P_{WO, 2T} = 32.5$ mW
011: $P_{WO, 2T} = 35$ mW
100: $P_{WO, 2T} = 38$ mW
101: $P_{WO, 2T} = 41$ mW
110: $P_{WO, 2T} = 45$ mW
111: $P_{WO, 2T} = 50$ mW

4.4.5.4 Optimum write power indication at HTS and '2T' Write-strategy

These 3 bits specify the optimum write power indication P_{WO} , applying '2T' write strategy at HTS recording. Optimum write power is specified in paragraph 2.2. These values are applicable for both US24 and US32 discs.

M1	S1	F1
0 - - - - - - -	1 - - - P7 P8 P9 -	0 - - - - - - -

P7 .. P9 for US24 and US32 (B1 .. B3 = 010 and 011)
000: $P_{WO, 2T}$ not specified
001: $P_{WO, 2T} = 30$ mW
010: $P_{WO, 2T} = 32.5$ mW
011: $P_{WO, 2T} = 35$ mW
100: $P_{WO, 2T} = 38$ mW
101: $P_{WO, 2T} = 41$ mW
110: $P_{WO, 2T} = 45$ mW
111: $P_{WO, 2T} = 50$ mW

4.4.5.5 Optimum erase power indication at 16x and '2T' write strategy

These 3 bits specify the optimum erase power indication P_{EO} , applying '2T' write strategy at 16x recording speed. These values are applicable for both US24 and US32 discs.

M1	S1	F1
0	1	0
-	-	E4 E5 E6
-	-	-
-	-	-
-	-	-

E4 .. E6 for US24 and US32 (B1 .. B3 = 010 and 011)
000: $P_{EO,2T}$ not specified
001: $P_{EO,2T} = 6$ mW
010: $P_{EO,2T} = 7$ mW
011: $P_{EO,2T} = 8$ mW
100: $P_{EO,2T} = 9.5$ mW
101: $P_{EO,2T} = 11$ mW
110: $P_{EO,2T} = 13$ mW
111: $P_{EO,2T} = 15$ mW

4.4.5.6 Optimum erase power indication at HTS and '2T' write strategy

These 3 bits specify the optimum erase power indication P_{EO} , applying '2T' write strategy at HTS recording. These values are applicable for both US24 and US32 discs.

M1	S1	F1
0	1	0
-	-	-
-	-	E7 E8 E9
-	-	-
-	-	-

E7 .. E9 for US24 and US32 (B1 .. B3 = 010 and 011)
000: $P_{EO,2T}$ not specified
001: $P_{EO,2T} = 6$ mW
010: $P_{EO,2T} = 7$ mW
011: $P_{EO,2T} = 8$ mW
100: $P_{EO,2T} = 9.5$ mW
101: $P_{EO,2T} = 11$ mW
110: $P_{EO,2T} = 13$ mW
111: $P_{EO,2T} = 15$ mW

CD-RW System Description

4.4.6 Additional Information 3 : M1,S1,F1 = 011

These three groups of 7 bits contain codes that uniquely identify each media.

Figure 4-11 Combinations and definitions of the bits in Additional Information 3

M1	S1	F1
0 J1 J2 Q1 Q2 Q3 Q4 Q5	1 Q6 Q7 Q8 Q9 Q10 Q11 Q12	1 Q13 Q14 Q15 Q16 R1 R2 R3

- J1..J2 : Media technology type
- Q1..Q12 : Media IDentification (MID) code first part
- Q13..Q16 : Media IDentification (MID) code second part
- R1..R3 : Product revision number

4.4.6.1 Media technology type: J1..J2

These 2 bits specify the type of technology of the recordable layer on the disc.

M1	S1	F1
0 J1 J2 - - - - -	1 - - - - - - - -	1 - - - - - - - -

- J1..J2 = 00 : Phase-change type recording layer
- 01 : Reserved
- 10 : Reserved
- 11 : Other type of recording layer

Media not behaving in accordance with type 00 (Phase-change) should be identified as type 11 (Other). The type is to be determined by the media manufacturer.

4.4.6.2 Media Identification (MID) code: Q1..Q16

These 16 bits contain a code that uniquely identify the Disc Manufacturer and the type of product.

M1	S1	F1
0 - - Q1 Q2 Q3 Q4 Q5	1 Q6 Q7 Q8 Q9 Q10 Q11 Q12	1 Q13 Q14 Q15 Q16 - - -

- Q1..Q12 : The MID code first part, represented by Q1..Q12, shall be issued and registered by Royal Philips Electronics.
If needed, a manufacturer can request additional codes.
- Q13..Q16 : The MID code second part can be used by the Disc Manufacturer to identify 16 (different) disc types in his product range.

Note: Media manufacturers shall implement different second part of the MID code for US24 and US32 disc types.

4.4.6.3 Product revision number: R1..R3

These 3 bits can be used to identify different versions of the same type of product.

M1	S1	F1
0 - - - - - - -	1 - - - - - - - -	1 - - - - - R1 R2 R3

R1..R3 : The Product revision number, represented by R1..R3, can be chosen freely by the Disc Manufacturer. However all discs with the same MID code Q1..Q16, although with different Product revision numbers, must have the same recording properties (only minor differences are allowed: Product revision numbers shall be irrelevant for recorders).

4.5 Error detection

The error detection method uses a 14 bits CRC on Minutes, Seconds and Frames. The CRC codeword must be divisible by the check polynomial. The most significant bit of the CRC codeword is bit 5, the least significant bit is bit 42 of the ATIP frame. The CRC parity bits (bit 29 .. 42) are inverted on the disc.

The check polynomial is :

$$P(X) = X^{14} + X^{12} + X^{10} + X^7 + X^4 + X^2 + 1$$

4.6 Bit rate

Bit rate = nr of addresses/sec * nr of bits/address
 = 75 * 42
 = 3150 bits/sec.

The bit rate is 1/7 of the 22.05 kHz wobble frequency. Both the 22.05 kHz wobble and 6.3 kHz biphasic clock frequencies are derived from the same 44.1 kHz source.

4.7 ATIP encoder

The block diagram of the ATIP encoder is :

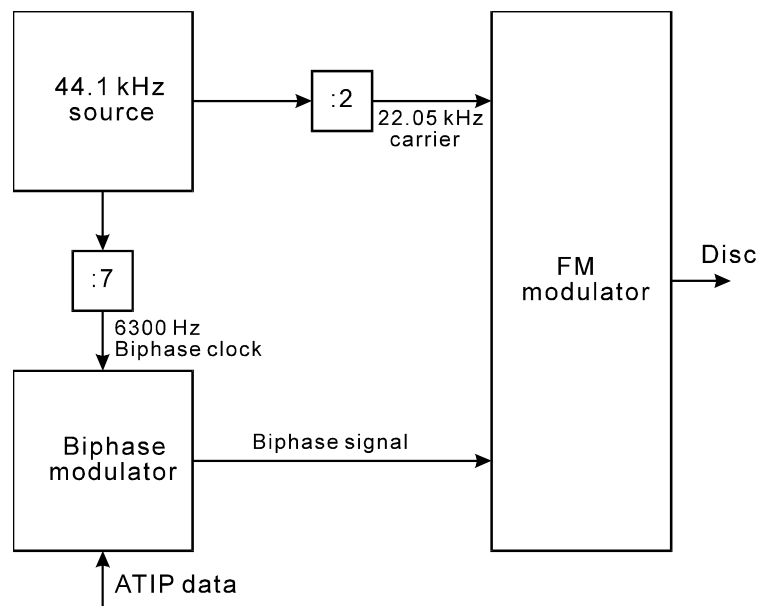

Figure 4-12 Block diagram of a typical ATIP encoder

This page is intentionally left blank

5. Data organization

- The encoding rules for CD-Audio Tracks are as given in the Red Book unless specified otherwise in this document.
- The encoding rules for Data Tracks are as given in the Yellow Book or the Green Book unless specified otherwise in this document. As this chapter 5 is written as an extension to the Red Book, some specification items must be replaced by the concerned items from the Yellow Book or Green Book, if recordings according to these books are made.
- Recording the complete disc (including Lead-in and Lead-out) in an uninterrupted single writing action is defined as **Uninterrupted Writing** or **Disc At Once** (DAO) recording. For an Uninterrupted written disc, the data organization must be as specified in the Red Book, the Yellow Book or the Green Book, whichever is appropriate, except for Subcode-Q mode 5 (see chapter 5.5).
- The Information Area of a CD-RW disc is divided into the following areas (see chapter 1.4.2 and Figure 12-1, Figure 12-2, Figure 12-3, Figure 12-7 and Figure 12-17):
 - 1: Power Calibration Area
 - 2: Program Memory Area
 - 3: One or more Sessions, each consisting of:
 - Lead-in Area
 - Program / Recordable Area
 - Lead-out Area

In this chapter the structure of the PCA, the PMA and a Session will be described. The structure of a Multisession disc is defined in chapter 11.

5.1 ATIP synchronization rule

Over the entire disc the allowed tolerance between the position of the ATIP sync and the Subcode sync is 0 ± 2 EFM frames.

The position of an ATIP-sync is defined as the position where a sync can be determined as a sync pattern; this means directly after the physical sync pattern on the disc.

The position of a Subcode-sync is defined as the start position of the physical sync pattern on the disc (see Figure 12-9).

The recorded Q-channel Absolute Time on any position of the disc is identical to the ATIP time at that position.

5.2 Linking rules

Recording the disc in several distinct writing actions (e.g. at different times, on different recorders) is defined as **Incremental Writing**. In case of Incremental Writing the linking rules must be taken into account. Also in the case of overwriting existing information, all linking rules have to be fulfilled.

5.2.1 General Linking Rules

(see Figure 12-10)

The Link Position is the physical location on the disc where the recording of EFM signals is allowed to start and stop.

The nominal Link Position is 26 EFM frames after the start of a Subcode-sync pattern.

No gap between the recordings is allowed. Between recordings, a maximum overwrite of 12 EFM frames is allowed.

The start and stop positions of the recordings must be in the following range:

- Start position: 26 ± 4 EFM frames after the start of the encoder Subcode-sync.
- Stop position: 26 ± 4 EFM frames after the start of the encoder Subcode-sync.

In the Power Calibration Area different linking rules are applied (see chapter 5.3).

5.2.2 Audio Linking

In the case of audio recording, at least 1 Interleave Length (about 15 milliseconds) of digital silence is recommended at the beginning and at the end of an EFM recording sequence (see Figure 12-11).

5.2.3 Data Linking

In the case of data recording, the EFM recording sequence shall start and end with Link, Run-in and Run-out blocks. One set of recorded Link, Run-in, User Data and Run-out blocks is called a Packet. The number of User Data blocks in a Packet is called the Packet Size.

Figure 5-1 Layout of a Packet

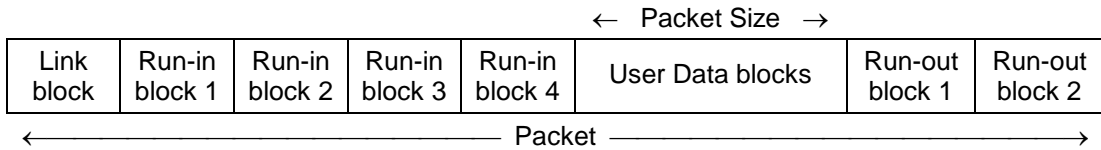

The start of a Block sync (before CIRC/EFM encoding with a minimum delay encoder, see Yellow Book page 33) is within -10 and +36 EFM frames after the start of a Subcode sync (see Figure 12-9).

Note: When the start of the Block sync is delayed more than about 16 EFM frames relative to the Subcode sync, then the last data bytes of Run-out block 1 can be expected to be flagged "uncorrectable" by the CIRC decoder due to the Interleave Length. The first data bytes of Run-out block 1, containing the Block Header, can be expected to be correct when the delay is within the specified limits.

The Link block is the block that nominally contains the Link Position as specified in chapter 5.2.1. Each EFM recording within a Data Track must be recorded as one Packet, so each recording must start with a (partial) Link block followed by four Run-in blocks, minimum one User Data block and two Run-out blocks and shall be closed with the first part of the next Link block (see Figure 12-11). As a consequence of this, a Link block inside a User-recorded area is always preceded by 2 Run-out blocks and followed by four Run-in blocks. The first Link block at the begin of a User-recorded area, adjacent to an unrecorded or logically erased area, is not preceded by Run-out blocks. The last Link block at the end of a User-recorded area, adjacent to an unrecorded or logically erased area, is not followed by Run-in blocks.

These rules also have to be fulfilled after overwriting a packet, which means that overwriting in an existing data track is only allowed between two existing link points.

Each Data Track must contain minimum one Packet with user Data. At the beginning and at the end of the Lead-in and Lead-out Areas, the recording of Run-in and Run-out blocks is optional.

Identification of the Link, Run-in, User Data and Run-out blocks is in the Mode byte (in the Block Header, see Yellow Book page 101). The lay-out of this Mode byte is given in Figure 5-2 (bit 7 is first bit and MSB).

Figure 5-2 Layout of the Mode byte

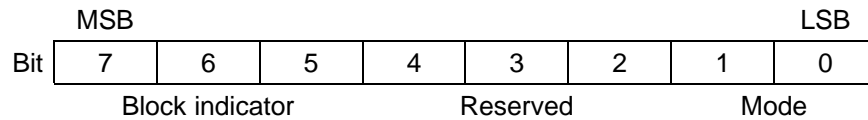

- bit 7..5 : Block indicators
 - = 000 : User Data block
 - = 001 : Fourth Run-in block
 - = 010 : Third Run-in block
 - = 011 : Second Run-in block
 - = 100 : First Run-in block
 - = 101 : Link block: physical linking of EFM data according to the General Linking Rules in chapter 5.2.1
 - = 110 : Second Run-out block
 - = 111 : First Run-out block

- bit 4..2 : Reserved and set to 000

- bit 1..0 : Yellow Book Mode indication
 - = 00 : mode 0
 - = 01 : mode 1
 - = 10 : mode 2
 - = 11 : Reserved

5.2.3.1 Use of RID code in data applications

(optional, see also chapter 5.4.5)

For Consumer CD-recorders the use of the RID code (Recorder Identification code) in mode 3 of the Subcode Q-channel is mandatory in audio recordings (see chapter 5.6.3.2). Professional CD-recorders can store their RID code in the User Data field of all Run-in and Run-out blocks at each data recording action. The content of the User Data field of the Run-in and Run-out Blocks containing the RID code is defined in Figure 5-3.

User Data byte	Contents
0..4	RID code identifier "RID01"
5..7	Reserved and set to 00h
8	RID Manufacturer Code (I1) 'A'..'Z'
9	RID Manufacturer Code (I2) 'A'..'Z'
10	RID Manufacturer Code (I3) 'A'..'Z'
11..15	Reserved and set to 00h
16	RID Recorder Type Code (I4) 'A'..'Z'
17	RID Recorder Type Code (I5) 'A'..'Z'
18	RID Recorder Type Code (I6) '0'..'9'
19	RID Recorder Type Code (I7) '0'..'9'
20..23	Reserved and set to 00h
24	RID Recorder Unique Number (0, I8)
25	RID Recorder Unique Number (I9, I10)
26	RID Recorder Unique Number (I11, I12)
27..31	Reserved and set to 00h
32..63	Manufacturer name
64..79	Supplementary Recorder Type Code
80..95	Supplementary Recorder Unique Number
96..255	Reserved and set to 00h
256..1023	Manufacturer specific
1024..2047	Reserved and set to 00h

Figure 5-3 Definition of the User Data bytes in the Run-in and Run-out blocks

The RID code for data applications is defined in a consistent way with the RID code for audio applications (see chapter 5.6.3.2).

- byte 0..4 = RID code identifier:
This field, coded in ISO 646 with the characters "RID01", indicate that this block contains RID code information.
- byte 5..7 = Reserved and set to 00h
- byte 8..10 = RID Manufacturer Code (I1..I3):
A 3-character code unique for each recorder manufacturer, coded in ISO 646. This code shall be issued and registered by Royal Philips Electronics (see also chapter 5.6.3.2.1).
- byte 11..15 = Reserved and set to 00h

- byte 16..19 = RID Recorder Type Code (I4..I7):
A 4-character code unique for each recorder model, coded in ISO 646.
This code is defined by the recorder manufacturer.
- byte 20..23 = Reserved and set to 00h
- byte 24..26 = RID Recorder Unique Number (0, I8..I12):
A unique 20-bit binary serial number for each single recorder unit. The first 4 bits of byte 24 are set to "0000". Each following 4 bits represent one of I8..I12. The fifth bit of byte 24, corresponding to the first bit of I8, is the msb of the number; the last bit of byte 26, corresponding to the last bit of I12, is the lsb of the number.
- byte 27..31 = Reserved and set to 00h
- byte 32..63 = Manufacturer name:
This ISO 646 coded field optionally contains the full name of the recorder manufacturer. If not used this field shall be filled with 00h.
- byte 64..79 = Supplementary Recorder Type Code:
The contents of this ISO 646 coded field is defined by the recorder manufacturer. If not used this field shall be filled with 00h.
- byte 80..95 = Supplementary Recorder Unique Number:
The contents of this ISO 646 coded field is defined by the recorder manufacturer. If not used this field shall be filled with 00h.
- byte 96..255 = Reserved and set to 00h
- byte 256.. 1023 = Manufacturer specific:
Information to be defined by the recorder manufacturer.
- byte 1024..2047= Reserved and set to 00h

5.3 Power Calibration Areas

The Power Calibration Areas (PCA1 and PCA2) are reserved to determine the correct recording power for a disc. Each PCA is divided into two areas (see Figure 12-7 and Figure 12-8):

- 1: The **Test Area**, in which tests with random EFM data can be performed to obtain the correct recording power for a disc.
- 2: The **Count Area**, where can be read which part of the Test Area can be used.

Both areas of the PCA1 and PCA2 are divided into partitions, which must be used in sequential order, starting from partition number one. PCA1 and PCA2 can be used many times: once all partitions have been used, the total PCA1 or PCA2 must be CW-erased, after which it is available for the next sequence of power calibration procedures.

5.3.1 Test Areas

PCA1:

The Test Area is reserved for performing OPC (Optimum Power Control) procedures as described in attachment 13.3. The start time is 01:05:65 ATIP before the start of the Lead-in Area. It ends with the frame 00:45:26 before the start of the Lead-in Area, which is the last frame of the Test Area. The next frame (because of a jump of 30 seconds in the ATIP time-code) is 00:15:25 ATIP before the start of the Lead-in Area, which is the start of the Count Area (see Figure 12-7). The start of the Lead-in Area is encoded in ATIP during the Lead-in Area (see chapter 4.4).

The Test Area is divided into 100 numbered partitions. Partition numbering increases from 1 to 100 from outside to inside disc diameter (backwards numbering from the end of the Test Area to the start, see Figure 12-7).

Each partition is 15 ATIP frames long (15/75 seconds). Each partition number p starts at a fixed ATIP time, and ends at the start of partition $(p-1)$. Partition p starts $(p*15 + 1160)$ ATIP frames before the start of the Lead-in Area (see Figure 12-7).

The Test Area starts with 30 and ends with 10 reserved ATIP frames, to facilitate the search for the start of partition 100 of the Test Area and the start of the Count Area.

The nominal Link Position for both starting and stopping has to be 0 ± 2 EFM frames after the end of the ATIP-sync (this is different from the General Linking Rules).

PCA2:

The Test Area 2 is reserved for performing OPC (Optimum Power Control) procedures as described in attachment 13.3. The start time is SLO + 00:30:00. It ends at SLO + 00:52:40, which is the start of the Count Area2. The Test Area2 is also divided into 100 numbered partitions. Partition numbering increases from 1 to 100 from outside to inside disc diameter (backwards numbering from the end of the Test Area2 to the start, see Figure 12-8).

Each partition is 15 ATIP frames long (15/75 seconds). Each partition number p starts at a fixed ATIP time, and ends at the start of partition $(p-1)$.

Partition p starts $(1530 - p*15)$ ATIP frames after the SLO + 00:30:00 (see Figure 12-8).

The Test Area2 starts and ends with 30 reserved ATIP frames, to facilitate the search for the start of partition 100 of the Test Area2 and the start of the Count Area2.

The nominal Link Position for both starting and stopping has to be 0 ± 2 EFM frames after the end of the ATIP-sync (this is different from the General Linking Rules).

5.3.2 Count Areas

The Count Areas provide a reliable and fast detection of the first usable, free partition in the Test Areas.

Count Area1:

The Count Area1 starts 00:15:25 ATIP before the start of the Lead-in Area, which is the end of the Test Area1. It ends 00:13:25 ATIP before the start of the Lead-in Area, which is the start of the Program Memory Area (see Figure 12-7).

Count Area1 is divided into 100 numbered partitions. Partition numbering increases from 1 to 100 from outside to inside disc diameter. Each partition in the Count Area1 is 1 ATIP frame long (1/75 seconds). Each partition p starts at a fixed ATIP time and ends at the start of partition number $(p-1)$. Partition p starts $(p*1 + 1030)$ ATIP frames before the start of the Lead-in Area (see Figure 12-7).

Count Area1 starts with 20 and ends with 30 reserved ATIP frames, to facilitate the search for the start of partition 100 of Count Area1 and the start of the Program Memory Area.

Partition p in Count Area1 must be recorded with EFM, after partition p in the Test Area1 has been used for performing an OPC procedure.

By counting the number of empty partitions E in the Count Area1 (from the start up to the first recorded partition), the first usable partition U in the Test Area is determined by $U=101-E$.

In the Count Area1, the recording of EFM data (random EFM allowed) has to be as specified for the rest of the Information Area, except for the Nominal Link Position as described in chapter 5.2.1. In the Count Area1, the Link Position for both starting and stopping has to be 0 ± 2 EFM frames after the end of the ATIP-sync.

Count Area2:

The Count Area2 starts at SLO + 00:50:60, which is the end of the Test Area2. It ends at SLO + 00:52:40. The Count Area2 is divided into 100 numbered partitions. Partition numbering increases from 1 to 100 from outside to inside disc diameter. Each partition in the Count Area2 is 1 ATIP frame long (1/75 seconds). Each partition p starts at a fixed ATIP time and ends at the start of partition number $(p-1)$. Partition p starts $(1660 - p*1)$ ATIP frames after the SLO + 00:30:00 (see Figure 12-8).

The Count Area2 ends with 30 reserved ATIP frames. Partition p in the Count Area2 must be recorded with EFM, after partition p in the Test Area2 has been used for performing an OPC procedure.

By counting the number of empty partitions E in the Count Area2 (from the start up to the first recorded partition), the first usable partition U in the Test Area2 is determined by $U=101-E$.

In the Count Area2, the recording of EFM data (random EFM allowed) has to be as specified for the rest of the Information Area, except for the Nominal Link Position as described in chapter 5.2.1. In the Count Area2, the Link Position for both starting and stopping has to be 0 ± 2 EFM frames after the end of the ATIP-sync.

5.4 Program Memory Area

The Program Memory Area (PMA) starts at 00:13:25 ATIP before the start of the Lead-in Area. It ends at the start time of the Lead-in Area, which is encoded in ATIP during the Lead-in Area (see chapter 4.4).

As long as the Lead-in Area is in the unrecorded or logically erased state, the PMA is used for intermediate storage. The PMA contains information about the recordings on the disc, this information is encoded in the Subcode Q-channel.

The use of the Program Memory Area is mandatory, except for Uninterrupted Written (DAO) discs, in which case it is optional. If the disc leaves the recorder then the PMA must contain the actual status of the complete contents of the disc.

5.4.1 Contents

The PMA can contain the following types of information:

- 1: Track numbers with their start and stop time. This is the table of contents for the partially recorded disc. The Track numbers of all Tracks (including Reserved and Incomplete Tracks, see chapter 5.4.1.1) in the PMA must be contiguous and increment by one.
- 2: Disc identification. A 24-bit binary number shall be recorded in the disc to identify each disc.
- 3: Skip information (optional). It is possible to indicate that an entire Track or a part of a recorded Track (a time interval) should be skipped during play back of the disc. The Skip feature is defined for Audio Sessions only.
- 4: The RID code in the User Data field of the blocks for Table Of Contents Items.

Examples of PMAs are given in Figure 12-12 and Figure 12-13.

5.4.1.1 Reserved Track

A Reserved Track is a Data Track, which is not yet completely recorded with User Data, but the start and the stop time of the Track are already recorded in the PMA. If a Reserved Track is not the first Track in the Program Area then the Reserved Track shall be of the same mode as the preceding Track (see attachment 13.7). Before the disc or the Session (see chapter 11) is finalized, all the Reserved Tracks in the finalized part of the disc must be User-recorded.

If a Reserved Track is not the first Track in the Program Area and no User Data is recorded in this Track, then the difference between the start time of the Reserved Track and the stop time of the previous Track must be 00:02:00.

If a Reserved Track is meant to be written incrementally with fixed packets, then the Track length and the Packet size must be determined in such a way that an integer number of Packets will fit in the Track (see Figure 0-7); this means that the start and stop time of the Track must be according to the following equation:

$$\text{Stop time} - \text{Start time} = \text{Number of packets} * (\text{Packet size} + 7) - 5$$

The start time of a Track shall be equal to the Header Address belonging to the first User Data block of the Track (see chapter 5.6.5.1). The stop time of a Track shall be equal to the Header Address belonging to the (partial) Link block at the end of the last Packet (see Figure 12-11) to be recorded in the Track.

5.4.1.2 Incomplete Track

An Incomplete Track is a Data Track in which a series of incrementally written data Packets can be recorded. At the start of the Incomplete Track a Pre-gap (see chapter 5.6.5.1) containing Track Descriptor Blocks (see chapter 5.6.5.2) must be recorded. The information about the Incomplete Track must be recorded in the PMA according to chapter 5.4.3.

It is allowed to have maximum one Incomplete Track on a disc. The Incomplete Track is the last Track in the last Session on the disc. The Track Number of the Incomplete Track is equal to the last Track recorded in the PMA.

5.4.2 Recording sequence

A recording action in the PMA must always be performed in a multiple of ten Subcode frames. Within such a **Unity** of ten frames, the successive frames are labelled 0 (first frame) to 9 (last frame) in the ZERO byte of the Subcode-Q channel. In the recorded part of the PMA, this ZERO byte must continuously repeat this cyclic counting from 0 to 9.

The specific contents, the information within a Subcode frame, is called an **Item**. An Item is repeated five times in five successive Subcode frames. As a Unity consists of ten Subcode frames, these five successive repetitions of an Item are labelled 0 to 4 or 5 to 9. When an uneven number of Items must be recorded, the last of these Items is repeated ten times instead of the usual five times, because recording must always be done in multiples of ten Subcode frames. In this case, the ten successive repetitions are labelled 0 to 9 in the ZERO byte.

A PMA sequence consists of a number of valid PMA unities, which do not contain mode 0 frames (see chapter 5.4.3.1). A PMA sequence is terminated by an unrecorded area of 10 frames or by one mode 0 Unity (a unity with ten Subcode-Q mode 0 frames).

Note: If the PMA sequence is terminated with a mode 0 Unity, then any data that follows the mode 0 Unity does not belong to the PMA sequence. If the PMA sequence starts with a mode 0 Unity, then the PMA sequence is empty.

The first Item in a PMA sequence is recorded at the start time of the PMA. Items specifying the start-, and stop times of Tracks (TOC Items) have to appear in order of increasing Track numbers. Other valid PMA Items can appear anywhere in the PMA sequence.

5.4.3 The Subcode-Q channel

The encoding of the Subcode-Q channel frame is: (see Figure 12-12 and Figure 12-13)

Figure 5-4 Encoding in the PMA of a Subcode-Q frame

S0,S1	CONTR	ADR	TNO	POINT	MIN	SEC	FRAME	ZERO	PMIN	PSEC	PFRAME	CRC
-------	-------	-----	-----	-------	-----	-----	-------	------	------	------	--------	-----

S0, S1 : The coding rules are according to the Red Book, page 40.

CONTROL : see CONTROL in chapter 5.6.3.1, except for bit 1 (the Copy Bit). If ADR=1 (TOC Item) then the Copy Bit is '1' (no copyright) only if the Copy Bit is '1' in all parts of the Track specified by POINT.

Note: The correct copyright status of a Track must always be checked in the Program Area. In case of doubt about the final copyright status of a Track (e.g. in case of a Reserved Track) the Copy bit in the PMA should be set to '0' (copyright protected). This can be different from the final Copy bit setting in the subcode-Q channel in the Lead-in Area.

TNO = 00

ZERO = 00..09: A counter which labels the successive frames in a Unity of ten Subcode frames. The first frame is labelled 0, the last is 9. The count sequence of overwritten Subcode frames shall be synchronized to previously written frames.

CRC : see Red Book page 41: 16 bit CRC on Control, ADR and Q-data (MSB first). On the disc the parity bits are inverted. The remainder have to be checked at zero. The check polynomial is: $P(X) = X^{16} + X^{12} + X^5 + 1$

ADR : The value in ADR determines what kind of information is in the Item (see chapter 5.4.1).

ADR = 1 : "Table Of Contents" Items: The Track numbers and start-, and stop times of all Tracks.

- a) POINT=01..99: the value of POINT = n, when the Track has Track number n.
- b) The value of PMIN, PSEC and PFRAME gives the start time of the Track, pointed to by POINT.
- c) The value of MIN, SEC, FRAME gives the stop time of the Track pointed to by POINT.

If the Track is the Incomplete Track (see chapter 5.4.1.2), then the value of MIN, SEC, FRAME is set to 'FF FF FF' (hex), which indicates a dummy stop time of the Incomplete Track. After the Incomplete Track has been completed, the part of the PMA containing the information about the Incomplete Track is overwritten and includes the actual value of the stop time.

- ADR = 2 : The "Disc Identification" Item. The use of this Item is mandatory. It may only be recorded once in the PMA. In this Item a statistically unique 24-bit binary number is recorded which can be used for the identification of each disc.
- a) MIN, SEC, FRAME each contain a binary encoded 8-bit number. The 24 bits together are the Disc Identification. This 24-bit number shall be determined at random.
 - b) PSEC specifies the format of the Data Sessions on the disc (all Data Sessions on a disc must be of the same format).
The allowed values (hex) are:
 - 00 : CD-DA or CD-ROM Sessions
 - 10 : CD-i Sessions
 - 20 : CD-ROM XA Sessions
 - FF : disc type undefined/unknown
 - All other values are reserved.
 - c) POINT, PMIN, PFRAME are reserved and set to zero.
- ADR = 3 : "Skip Track" Item. The use of this Item is optional for Audio Sessions (not allowed in Data Sessions). In each of these Items maximally six Track numbers can be noted which have to be skipped during play back. The maximum allowed number of Tracks to be skipped is 21.
If not used, ADR=3 is not present.
- a) POINT=01..04: The value of POINT is J, when this is the Jth "Skip Track" assignment that is noted in the PMA.
 - b) MIN, SEC, FRAME, PMIN, PSEC, PFRAME can each contain a Track number of a Track which has to be skipped during play back of the disc. If less than six Tracks are noted, the remaining bytes have to be set to zero.
- ADR = 4 : Reserved
- ADR = 5 : "Skip Time Interval" Items. The use of this Item is optional for Audio Sessions (not allowed in Data Sessions). These Items are used to indicate that a time interval in the Program Area of the disc has to be skipped during play back.
If not used, ADR=5 is not present.
- a) POINT=01..40: The value of POINT is M, when this is the Mth "Skip Time Interval" assignment that is noted in the PMA.
 - b) The value of PMIN, PSEC, PFRAME gives the start time of the "Skip Time Interval" number M, pointed to by POINT.
 - c) The value of MIN, SEC, FRAME gives the stop time of the "Skip Time Interval" number M, pointed to by POINT.
- ADR = 6..F : Reserved.

5.4.3.1 Erasing the PMA with Subcode-Q mode 0

A PMA sequence can be overwritten and can be terminated with a mode 0 Unity. A mode 0 Unity consists of ten successive Subcode-Q mode 0 frames, labelled 0..9 (see chapter 5.4.2).

Subcode-Q mode 0 in the PMA has the following contents:

Figure 5-5 Encoding in the PMA of a Subcode-Q mode 0 frame

S0,S1	CONTR	ADR	TNO	POINT	MIN	SEC	FRAME	ZERO	PMIN	PSEC	PFRAME	CRC
-------	-------	-----	-----	-------	-----	-----	-------	------	------	------	--------	-----

- S0, S1 : The coding rules are according to the Red Book, page 40.
- CONTROL = 0000 : These 4 bits are set to 0.
- ADR = 0 : These 4 bits indicate mode 0.
- TNO = 00
- POINT = 00
- MIN, SEC, FRAME = 00, 00, 00
- ZERO = 00..09 : A counter which labels the successive frames in a Unity of ten Subcode frames (see chapter 5.4.2). The first frame is labelled 0, the last is 9. The count sequence of overwritten Subcode frames shall be synchronized to previously written frames.
- PMIN, PSEC, PFRAME = 00, 00, 00
- CRC : These 16 bits are according to chapter 5.4.3

5.4.4 P, R..W Subcode channels

In the PMA the Subcode channels P, R..W are reserved, and set to zero.

5.4.5 RID code in the main channel

Professional CD-recorders, able to write the CD-ROM and/or the CD-i Format, shall write their RID code (see chapters 5.2.3.1 and 5.6.3.2.1) in the main channel of the Table Of Contents Items (subcode mode 1) in the PMA, whenever they record such an item. This RID code shall be block encoded with a User Data field as defined in Figure 5-6.

User Data byte	Contents
0..4	RID code identifier "RID01"
5..7	Reserved and set to 00h
8	RID Manufacturer Code (I1) 'A'..'Z'
9	RID Manufacturer Code (I2) 'A'..'Z'
10	RID Manufacturer Code (I3) 'A'..'Z'
11..15	Reserved and set to 00h
16	RID Recorder Type Code (I4) 'A'..'Z'
17	RID Recorder Type Code (I5) 'A'..'Z'
18	RID Recorder Type Code (I6) '0'..'9'
19	RID Recorder Type Code (I7) '0'..'9'
20..23	Reserved and set to 00h
24	RID Recorder Unique Number (0, I8)
25	RID Recorder Unique Number (I9, I10)
26	RID Recorder Unique Number (I11, I12)
27..31	Reserved and set to 00h
32..63	Manufacturer name
64..79	Supplementary Recorder Type Code
80..95	Supplementary Recorder Unique Number
96..127	Reserved and set to 00h
128..255	Reserved and set to 00h
256..1023	Manufacturer specific
1024..2047	Reserved for copy protection purposes

- byte 0..127 = Recorder identification: see chapters 5.2.3.1
- byte 128..255 = Reserved and set to 00h
- byte 256.. 1023 = Manufacturer specific: see chapters 5.2.3.1
- byte 1024..2047 = Reserved for copy protection purposes (if not used set to 00h)

Figure 5-6 Definition of the User Data bytes in the PMA main channel blocks

If the disc is an Uninterrupted written (DAO) disc, without a Table Of Contents recorded in the PMA, then the RID code shall be recorded in the main channel of the last Unity of ten frames (see chapter 5.4.2) at the end of the Program Memory Area (just before the start of the Lead-in Area). This RID code shall be block encoded with a User Data field as defined in Figure 5-6.

All subcode fields (see Figure 5-4) in this Unity shall be set to all zeros, except for the ZERO field, which shall count from 0 to 9 to label the successive frames in the Unity, and S0,S1 and the CRC field, which shall be encoded according to the normal rules (see chapter 5.4.3).

5.5 Lead-in Area

The Lead-in Area contains information about the disc (or the Session to which it belongs) and about the User-recorded Tracks.

A Lead-in Area can be in one of the following states:

- unrecorded;
- finalized, the TOC must be in accordance with the contents of the PMA (only Copy bit is allowed to be different, see chapter 5.4.3);
- logically erased, the Lead-in Area has been recorded, however it does not contain TOC information (see chapter 5.5.2.1).

In the Lead-in, information is encoded in the Subcode Q-channel. The Subcode-Q modes are used according to the Red Book.

In a finalized Lead-in Area the following Subcode modes are present:

Mode 1 is always present. The format of mode 1 is according to the Red Book, and contains the start positions of the recorded Tracks. See chapter 5.5.2 mode 1.

Mode 5 is always present, also on Uninterrupted Written (DAO) discs. Within mode 5 the identification of the CD-RW disc is defined, see chapter 5.5.2 mode 5.

Optionally, mode 5 can contain information about recorded Tracks or parts (Time Intervals) of recorded Tracks that should be skipped during play back of the disc.

Mode 1 and mode 5 must be placed in alternating order, each Subcode block being repeated three times. Mode 1 and mode 5 each occupy at least 3 out of 10 successive Subcode blocks.

Mode 6 is always and only present in the first Lead-in Area. Mode 6 shall contain a copy of the "Disc Identification" Item as recorded in the PMA (ADR = 2), see chapter 5.5.2 mode 6. Mode 6 shall occupy at least 1 out of 100 successive Subcode blocks.

5.5.1 ATIP/Subcode synchronization

In the Lead-in Area the time value encoded in MIN, SEC, FRAME of Subcode channel-Q is identical to the ATIP time-code.

The end of the Lead-in Area is encoded with a time-code of 99 Minutes, 59 Seconds, 74 Frames in both ATIP and Subcode-Q.

5.5.2 Table of Contents

When a Session on a CD-RW disc is finalized, the Lead-in Area with the Table of Contents is written. After finalization, the TOC must contain the actual status of the complete contents of that Session. Additional recordings are possible, either in a new Session (Multisession: see chapter 11), or in the same Session by overwriting (parts of) the Program Area, the Lead-in Area and the Lead-out Area.

If the complete disc has to be readable on a CD-ROM (or CD-DA) drive, then all Sessions must be finalized.

The Lead-in Area with the Table of Contents of the first (or only) Session starts at the start time as indicated in ATIP (see chapter 4.4.2). This Lead-in area ends at Absolute Time 99:59:74, this corresponds to diameter 50 +0.0/-0.4 mm.

In the TOC the Items are repeated three times each. The complete TOC is continuously repeated during the Lead-in Area. Mode 1 and mode 5 must be repeated separately (see Figure 12-14 and Figure 12-15).

Figure 5-7 Encoding in the Lead-in Area of a Subcode-Q frame

S0,S1	CONTROL	ADR	00	POINT	MIN	SEC	FRAME	ZERO	PMIN	PSEC	PFRAME	CRC
-------	---------	-----	----	-------	-----	-----	-------	------	------	------	--------	-----

TNO

S0, S1 : According to the Red Book page 40.

CONTROL : See CONTROL in chapter 5.6.3.1, except for bit 1 (the Copy Bit). If ADR=1 (TOC Item) then the Copy Bit is '1' (no copyright) only if the Copy Bit is '1' in all parts of the Track specified by POINT.

Note: The correct copyright status of a Track must always be checked in the Program Area.

TNO : 00

CRC : see Red Book page 41: 16 bit CRC on Control, ADR and Q-data (MSB first). On the disc the parity bits are inverted. The remainder have to be checked at zero. The check polynomial is: $P(X) = X^{16} + X^{12} + X^5 + 1$

ADR = 1 : Mode 1

MIN, SEC, FRAME :

indicate Absolute Time on the disc. They must be identical to the ATIP-time.

ZERO = 00

POINT = 01 .. 99 :

The value of PMIN, PSEC and PFRAME gives the start position of the recorded Track pointed to by POINT.

POINT = A0 :

a) PMIN gives the value of the first recorded Track number in the Program Area.

b) PFRAME is 00.

c) PSEC specifies the Session format.

The allowed values (in hex) are:

00 : CD-DA and CD-ROM

10 : CD-i

20 : CD-ROM-XA

POINT = A1 :

a) PMIN gives the value of the last recorded Track number in the Program Area.

b) PSEC and PFRAME are 00.

POINT = A2 :

PMIN, PSEC and PFRAME gives the start position of the Lead-out Area.

ADR = 5 : Mode 5

POINT=B0

This pointer, together with POINT=C0 is used for the identification of the CD-RW disc. POINT=B0 is always present in the Lead-in Area of all Sessions on the disc.

a) MIN, SEC, FRAME give the start time of the next possible Program Area in the Recordable Area of the CD-RW disc.

If the last Session on a CD-RW disc is designated as the Final Session of that disc, then MIN, SEC, FRAME shall contain the values 'FF, FF, FF' (hex).

b) PMIN, PSEC, PFRAME give the maximum start time of the outermost Lead-out Area in the Recordable Area of the CD-RW disc (copied from ATIP).

c) ZERO gives the total number of different pointers present in mode 5 (including any Audio Skip pointers).

POINT=C0

This pointer, together with POINT=B0, is used for the identification of a CD-RW disc. POINT=C0 is always and only present in the first Lead-in Area of a CD-RW disc.

MIN, SEC and FRAME contain a copy of the corresponding ATIP fields, encoded during the Lead-in Area (see chapter 4.4), in the specially encoded ATIP frames with MSB combination 101 (Special Information 1, see chapter 4.4.1):

a) MIN : This value must be copied from the value, encoded in the ATIP "Minutes" byte of the ATIP frames with MSB combination 101.

Bit 7..1 : W1..W3, X1, V1..V3 (bit 7 = MSB)

Bit 0 = 0

b) SEC : This value must be copied from the value, encoded in the ATIP "Seconds" byte of the ATIP frames with MSB combination 101.

Bit 7..1 : U1..U7 (bit 7 = MSB)

Bit 0 = 0

c) FRAME : This value must be copied from the value, encoded in the ATIP "Frames" byte of the ATIP frames with MSB combination 101.

Bit 7..1 : D1, B1..B3, A1..A3 (bit 7 = MSB)

Bit 0 = 0

Note: Bits A1..A3 indicate the presence of Additional Information 1, 2 and 3 in ATIP. They are not related to the presence of the pointers C1, C2 and C3 in the TOC.

d) ZERO : Reserved and set to 00.

e) PMIN, PSEC, PFRAME :

give the start time of the first Lead-in Area of the disc.

POINT=C1

This pointer, only present in the first Lead-in Area, gives additional information about the CD-RW disc. POINT=C1 shall only be present if the Additional Information 1 is present in ATIP. The contents of POINT=C1 shall be a copy of the contents of Additional Information 1.

MIN, SEC and FRAME contain a copy of the corresponding ATIP fields, encoded during the Lead-in Area (see chapter 4.4), in the specially encoded ATIP frames with MSB combination 001 (Additional Information 1, see chapter 4.4.4).

- a) MIN : This value must be copied from the value, encoded in the ATIP "Minutes" byte of the ATIP frames with MSB combination 001.
Bit 7..1 : L1..L3, H1..H4 (bit 7 = MSB)
Bit 0 = 0
- b) SEC : This value must be copied from the value, encoded in the ATIP "Seconds" byte of the ATIP frames with MSB combination 001.
Bit 7..1 : P1..P3, G1..G3, Y1 (bit 7 = MSB)
Bit 0 = 0
- c) FRAME : This value must be copied from the value, encoded in the ATIP "Frames" byte of the ATIP frames with MSB combination 001.
Bit 7..1 : E1..E3, Z1..Z4 (bit 7 = MSB)
Bit 0 = 0
- d) ZERO, PMIN, PSEC, PFRAME : Reserved and set to zero.

POINT=C2,C3

These pointers are reserved for future extensions and shall not be used.

ADR = 5 : Mode 5

Audio Skip pointers (see Figure 12-14)

POINT = B1

This pointer is used to indicate that an Audio Session contains Intervals and/or Tracks that should be skipped during playback (not allowed in Data Sessions).

- a) MIN, SEC, FRAME, ZERO, PFRAME = 00
- b) PMIN gives the number N ($N \leq 40$) of Skip Interval Pointers POINT=01..N.
- c) PSEC gives the number M ($M \leq 21$) of Skip Track assignments in POINT=B2..B4.

If no Skip Interval Pointers and no Skip Track assignments are used, POINT=B1 is not present.

POINT = B2..B4

Each of these pointers indicates maximally seven Track numbers that should be skipped during playback. The number M of used Skip Track assignments is given in PSEC of POINT=B1. If no Skip Track assignments are used ($M=0$), POINT=B2..B4 are not present.

- a) MIN, SEC, FRAME, ZERO, PMIN, PSEC, PFRAME each give a value of a Track number that should be skipped during play back. Remaining, unused bytes within a block must be filled with 00.

POINT = 01..40

These are the Skip Interval Pointers. They indicate an Interval (time interval) on the recorded disc that should be skipped during play back. Intervals must be recorded chronologically. The number N of used Skip Interval Pointers is given in PMIN of POINT=B1. If no Skip Interval Pointers are used ($N=0$), POINT=01..40 are not present.

- a) The value of PMIN, PSEC, PFRAME gives the start time of an Interval on the disc that should be skipped during play back.
- b) The value of MIN, SEC, FRAME gives the stop time of the Interval indicated in a).
- c) ZERO = Reserved and set to 00

Remark: Different Skip Intervals must not overlap each other, and Skip Intervals must not overlap with Skip Track assignments.

ADR = 6 : Mode 6

Disc Identification

POINT = 00

This pointer is used to identify the disc by a statistically unique 24-bit binary number. Mode 6, POINT=00 is only present in the first Lead-in Area (also on a Single Session disc).

MIN, SEC, FRAME :

indicate Absolute Time on the disc. They must be identical to the ATIP-time.

ZERO = 00

PMIN, PSEC and PFRAME shall contain a copy of the Disc Identification Item as recorded in the PMA with ADR = 2 (see chapter 5.4.3).

PMIN shall be equal to the MIN field of the Subcode blocks with ADR = 2 in the PMA.

PSEC shall be equal to the SEC field of the Subcode blocks with ADR = 2 in the PMA.

PFRAME shall be equal to the FRAME field of the Subcode blocks with ADR = 2 in the PMA.

POINT = 01..99 :

Reserved for future extensions.

5.5.2.1 Erasing the Lead-in Area with Subcode-Q mode 0

If the CD-RW disc or a Session on the CD-RW disc has to be overwritten, the Lead-in area can be logically erased by overwriting the whole area with a signal containing Subcode-Q mode 0 and Subcode-Q mode 5 in an alternating order as specified in chapter 5.5. In this sequence, Subcode-Q mode 5 is as specified in chapter 5.5.2 with contents adapted to the new situation. Until the Session is finalized again, MIN, SEC, FRAME of POINT=B0 shall be set to 'FF, FF, FF' (see attachment 13.1.5). Subcode-Q mode 1 is replaced with Subcode-Q mode 0, with the following contents:

Figure 5-8 Encoding in the Lead-in Area of a Subcode-Q mode 0 frame

S0,S1	CONTR	ADR	TNO	POINT	MIN	SEC	FRAME	ZERO	PMIN	PSEC	PFRAME	CRC
-------	-------	-----	-----	-------	-----	-----	-------	------	------	------	--------	-----

- S0, S1 : The coding rules are according to the Red Book, page 40.
- CONTROL = 0000 : These 4 bits are set to 0.
- ADR = 0 : These 4 bits indicate mode 0.
- TNO = 00
- POINT = 00
- MIN, SEC, FRAME : indicate Absolute Time on the disc.
They must be identical to the ATIP-time.
- ZERO = 00
- PMIN, PSEC, PFRAME = 00, 00, 00
- CRC : These 16 bits are according to chapter 5.5.2

5.5.3 Subcode/Header synchronization

If the Lead-in Area is encoded as a Data Track (see Yellow Book chapter VI.3) then the Header address and the Subcode-Q Relative Time before CIRC/EFM encoding with a minimum delay encoder (see Yellow Book page 33) must be identical.

5.6 Program Area

The Program Area consists of Tracks which are User-recorded, reserved or incomplete. The Program Area can be recorded partially, in which case there can be unrecorded or logically erased areas. Unrecorded or logically erased areas are only allowed at the end of Reserved Tracks and at the end of the last Program Area (see chapters 5.4.1.1 and 5.4.1.2). Recordings can be made by overwriting pieces of a recorded area or by writing in an unrecorded or logically erased area of the disc. Overwriting in previously recorded data tracks is only allowed to start and stop at existing link points. Writing in an unrecorded or logically erased area has to start at the beginning of a Reserved Track or has to be linked directly to the end of the last User-recording before the unrecorded or logically erased area.

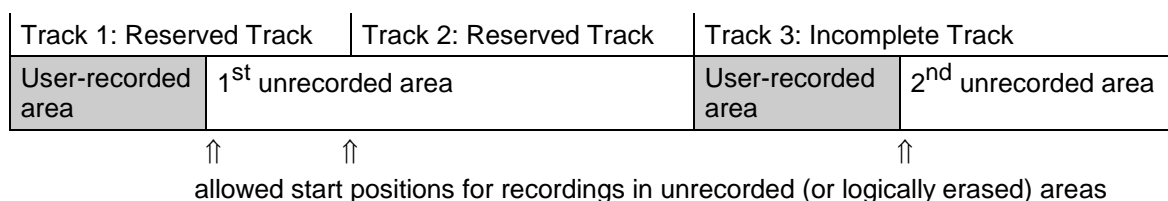

Figure 5-9 Example of start positions for recordings in unrecorded areas

Any recording must fulfil all the linking rules (see chapter 5.2) and has to be according to the Track attributes as described in the Track Descriptor Block for data tracks (see chapter 5.6.5.2).

5.6.1 ATIP/Subcode synchronization

In the Program Area the Subcode-Q Absolute Time is identical to the ATIP time-code. The first ATIP and Subcode-Q time-code in the Program Area is zero (0 Minutes, 0 Seconds, 0 Frames).

5.6.2 Subcode/Header synchronization

The Header address and the Subcode-Q Absolute Time before CIRC/EFM encoding with a minimum delay encoder (see Yellow Book page 33) are identical.

5.6.3 Subcode Q-Channel

5.6.3.1 Subcode Q-Channel mode 1

The Q-channel data in the Program Area are according to the Red Book except when specified otherwise in this chapter:

Figure 5-10 Encoding in the Program Area of a Subcode-Q mode 1 frame

S0,S1	CONTROL	1	TNO	INDEX	MIN	SEC	FRAME	ZERO	AMIN	ASEC	AFRAME	CRC
ADR												

- CONTROL** : Identification of the kind of information within a Track (bit 3 is first bit and MSB).
- bit 3..0** : The Encoding Identification. The only allowed change of the Encoding Identification within a Track is between "audio without pre-emphasis" and "audio with pre-emphasis".
- = 00x0 : 2 audio channels without pre-emphasis
 - = 00x1 : 2 audio channels with pre-emphasis
 - = 01x0 : Data Track, recorded uninterrupted.
 - = 01x1 : Data Track, recorded incremental.
 - = 10x0 : Reserved
 - = 10x1 : Reserved
 - = 11x0 : Reserved
 - = 11x1 : Reserved
- bit 1** : The three states of this Copy Bit are: continuous 1, continuous 0, or alternating 1 and 0. It is allowed to change the state of the Copy Bit during a Track. The use of the Copy Bit states is defined in attachment 13.9.
- = continuous 0 : Track is copy-right protected.
 - = continuous 1 : Track is not copy-right protected, and copying is permitted.
 - = alternate 1/0 : Track is first or higher generation copy of a copy-right protected Track. The frequency for alternating between 1 and 0 is 9.375 Hz (duty-cycle 50%), which means successively four Subcode frames 1 and four frames 0.
- ADR = 1** : Mode 1
- TNO, INDEX** : Track- and Index-number
- MIN, SEC, FRAME** : Relative Time within a Track.
- ZERO** : Reserved and set to 00
- AMIN, ASEC, AFRAME** : Absolute Time in-line with ATIP of unrecorded disc
- CRC** : see Red Book page 41: 16 bit CRC on Control, ADR and Q-data (MSB first). On the disc the parity bits are inverted. The remainder have to be checked at zero. The check polynomial is: $P(X) = X^{16} + X^{12} + X^5 + 1$

5.6.3.2 Subcode Q-Channel mode 3

Consumer CD-recorders shall write mode 3 of the Subcode Q-channel to record the following codes:

- the ISRC (International Standard Recording Code) according to the Red Book,
- the RID code (Recorder IDentification code) according to this specification, and
- a TBD code, the contents of which are reserved for future use.

These codes are encoded in 60 bits of the Subcode frame, grouped into 12 bit groups according to Figure 5-11:

- I1 .. I5, each consisting of 6 bits, occupying bit positions 0 .. 29
- I6 .. I12, each consisting of 4 bits, occupying bit positions 32 .. 59

The identification of the 3 different codes is achieved by C1,C2 on bit positions 30 and 31, between I5 and I6.

Figure 5-11 Encoding in the Program Area of a Subcode-Q mode 3 frame

S0,S1	CONTROL	3	I1 I2 I3 I4 I5	C1 C2	I6 I7 I8 I9 I10 I11 I12	ZERO	AFRAME	CRC
		ADR	6 bits each	2 bits	4 bits each			

- C1C2 = 00 : I1 .. I12 = ISRC code : according to Red Book, section 4.3
- = 11 : I1 .. I12 = RID code : see below
- = 01 : I1 .. I12 = TBD code : Reserved, all bits set to 0
- = 10 : not used

ZERO: 4 bits = 0000

AFRAME: 8 bits = the frame value of the Absolute Time, in-line with ATIP of unrecorded disc

5.6.3.2.1 Data format of the RID code

I1 .. I5 are representing alphanumeric characters, coded in a 6-bits format according to the Red Book, section 4.3.

I6 and I7 are coded as two 4-bits BCD numbers.

I8 .. I12 are coded as one 20-bits unsigned binary number with MSB first.

The RID code is composed of 3 groups in the following way:

- group 1: I1, I2 and I3 represent the Manufacturer Code (example: "PHI")
- group 2: I4, I5 and I6, I7 represent the Type Code (example: "CR 27")
- group 3: I8 .. I12 represent a Recorder Unique Number (example: "87532")

Example of complete RID code: "PHI CR 27 87532"

Note: The Manufacturer Code shall be issued and registered by Royal Philips Electronics (for detailed address see "Conditions of publication" in this document). The Type Code and the Recorder Unique Number (unique for each single recorder unit) are defined by the recorder manufacturer.

5.6.3.2.2 General format of mode 3

In the Program Area mode 3 shall occupy 1 out of 100 ± 5 successive Subcode frames.

All 3 codes shall be written in the following repeated sequence from the start of the Track (Index 1): 2 ISRC entries, 1 RID entry, 2 ISRC entries, 1 TBD entry, and so on.

If the ISRC is not used, then all bits in I1 .. I12 of the ISRC must be set to 0.

If the TBD code is not used, then the RID code is used instead of the TBD code, or all bits in I1 .. I12 of the TBD code must be set to 0.

In CD-RW, multiple ISRC codes within one Track are allowed.

5.6.3.3 Erasing the Program Area with Subcode-Q mode 0

If a part of the CD-RW disc or a Session on the CD-RW disc has to be erased, it is recommended to logically erase the concerned part of the Program Area and the Lead-out area by overwriting these areas with a signal containing Subcode-Q mode 0, with the following contents (see attachment 13.1.5 and 13.1.6):

Figure 5-12 Encoding in the Program Area of a Subcode-Q mode 0 frame

S0,S1	CONTR	ADR	TNO	INDEX	MIN	SEC	FRAME	ZERO	AMIN	ASEC	AFRAME	CRC
-------	-------	-----	-----	-------	-----	-----	-------	------	------	------	--------	-----

S0, S1	:	The coding rules are according to the Red Book, page 40.
CONTROL	=	0010 : If the main channel is structured like an Audio Track. 0110 : If the main channel is structured like a Data Track.
ADR	=	0 : These 4 bits indicate mode 0.
TNO	=	FF
INDEX	=	FF
MIN, SEC, FRAME	=	00, 00, 00
ZERO	=	00
AMIN, ASEC, AFRAME	:	Indicate Absolute Time on the disc. They must be identical to the ATIP-time.
CRC	:	These 16 bits are according to chapter 5.5.2

An erased area can start at the begin of the Program Area or at a Link Position in the Program Area. An erased area can stop at a Link Position in the Program Area or at the end of the Program Area.

A Session with an erased area is a **non-finalized** Session, which means that also the Lead-in and the Lead-out area have to be erased.

Because all Sessions on a Multisession CD, except the last one, have to be finalized, only the last Session on a Multisession CD is allowed to contain erased areas.

The main channel in the erased area does not contain any specific information. Link, Run-in or Run-out blocks are optionally allowed in an erased area. In the case of a data structured erase, the Data Blocks are formatted according to the Yellow Book, with the Block Headers containing the normal Header Address, and the Mode byte indicating User Data Blocks (see Figure 5-2).

After an erase action, the content of the PMA has to be adapted according to the actual status of the disc and has to fulfil all requirements concerning the Track numbers and start and stop times of all Tracks, including Reserved Tracks and Incomplete Tracks (see chapter 5.4).

5.6.4 P, R..W Subcode channels

The P-bit = 1 for the first two seconds in the Program Area. For the remainder of the disc, the P-bit must be either set to zero or be used as specified in the Red Book.

The channels R..W are according to the Red Book. If they are not used they must be zero.

5.6.5 Data Tracks

Every Data Track must start with a Pre Gap. It is recommended that every uninterrupted written data Track is ended with a Post Gap of minimum 2 seconds.

5.6.5.1 The Pre Gap

The use of the Pre Gap is clarified in attachment 13.7.

- When the use of a Pre Gap is prescribed in the Yellow Book or the Green Book, the definitions according to these books must be used. The second part of this Pre Gap contains the Track Descriptor Block (see chapter 5.6.5.2).
- When no Pre Gap is prescribed according to the Yellow Book or the Green Book, a Pre Gap of 2 seconds (150 blocks) must be recorded. This Pre Gap contains the Track Descriptor Block.

The Pre Gap is characterized by:

a: In the Subcode Q-Channel:

- * INDEX = 00
- * Relative time (MIN, SEC, FRAME) decreases to 00:00:00 at the end of the Pre Gap.

b: In the main channel:

- * The data is block encoded according to one of the Mode numbers as specified in the Yellow Book or the Green Book.

If a Track is written incrementally, then the (second part of the) Pre Gap must be composed of one Packet, in such away, that after writing the first User Data packet in the Track, the Pre Gap ends with the fourth Run-in block. The header address of the first User Data Block in the Track must be the start time of the Track, see Figure 5-13.

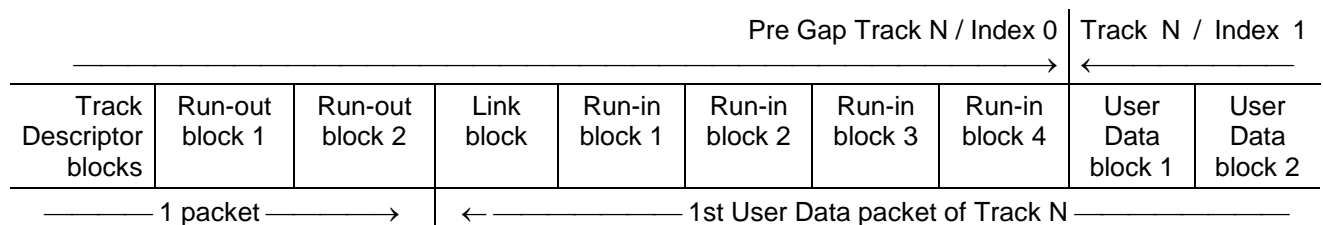

Figure 5-13 Linking of the first User Data in the Track to the Pre Gap

If a Track is not written incrementally, then the (second part of the) Pre Gap and all User Data Blocks in the Track must be recorded in one Packet; this is called Track At Once (TAO) recording.

5.6.5.2 The Track Descriptor Block

(see Figure 12-16)

The Track Descriptor Block is mandatory for Incremental written Data Tracks (packet writing), for Track At Once (TAO) recording, and for Data Tracks written in a Session At Once (SAO) recorded Session. For Tracks written during Disc At Once (DAO), it is recommended not to write the Track Descriptor Block.

The Track Descriptor Block contains in the User Data Field information about the Track attributes of the current Track.

The User Data Field within a Track Descriptor Block consists of two parts:

- a: Track Descriptor Table. This table is at the beginning of each User Data Field and is eight bytes long (see chapter 5.6.5.2.1).
- b: One Track Descriptor Unit. A unit consists of sixteen bytes. The Track Descriptor Unit is placed directly after the Track Descriptor Table (see chapter 5.6.5.2.2).

Not used bytes between the end of the Track Descriptor Unit and the end of the User Data field of a Track Descriptor Block are filled with zeros.

5.6.5.2.1 The Track Descriptor Table

The contents of these eight bytes in the main channel are (see Figure 12-16):

- Byte 0..2 : **Track Descriptor Identification.**
These three bytes contain the Hexadecimal code: '54 44 49' (ASCII "TDI").
- Byte 3..4 : Pre Gap length.
The number of blocks of the second part of this Pre Gap, encoded in BCD.
- Byte 5 : Indicates which Track Descriptor Units are present.
= 00 : Reserved (for CD-R).
= 01 : Indicates that only the Track Descriptor Unit of the current Track is present in this Track Descriptor Block.
= others : Reserved.
- Byte 6 : The number of the current Track, encoded in BCD.
- Byte 7 : The number of the current Track, encoded in BCD.

5.6.5.2.2 The Track Descriptor Unit

A Track Descriptor Unit consists of 16 bytes in the main channel. They describe the Data attributes of a Track. The contents of these 16 bytes are (see Figure 12-16):

- Byte 0 : Number of the Track to which this Track Descriptor Unit belongs, BCD encoded.
- Byte 1 : Write method of the Track (bit 7 = MSB).
Bit 7..4 = 1000 : Uninterrupted written Data Track.
The Track consists of only one Packet.
Bit 3..0 : Reserved and set to zero.
- = 1001 : Incremental written Data Track.
The Track consists of more than one Packet.
Bit 3..0 = 0000 : variable Packet Size.
= 0001 : fixed Packet Size.
= other : Reserved.
- = 0000 : Uninterrupted written Audio Track.
Bit 3..0 : Reserved and set to zero.
- = other : Reserved.
Bit 3..0 = Reserved.
- Byte 2..4 : Packet Size.
a: For Incremental written Tracks with fixed Packet Size (Byte 1='91' hex), these bytes contain the BCD encoded Packet Size in blocks (MSByte first).
b: For Incremental written Tracks with variable Packet Size (Byte 1='90' hex), and Uninterrupted written Data Tracks (Byte 1='80' hex), these three bytes contain the code 'FF FF FF' (hex).
- Byte 5..15 : Reserved and set to zero.

5.6.6 ATIP/Header synchronization

The start of a Block-Sync (before encoding with a minimum delay encoder, see Yellow Book page 33) is within -10 and +36 EFM frames after the (detected) ATIP Sync (see Figure 12-9).

5.7 Lead-out Area

5.7.1 Lead-out Area

If the disc is a single Session disc, then the recorded EFM in the Lead-out Area is encoded according to the rules given in the Red Book. The Lead-out Area is at least 1.0 mm in diameter wide, with a minimum recording time of 1 minute and 30 seconds.

If the disc is a Multisession disc, then the recorded EFM in each Lead-out Area is encoded according to the rules given in the Multisession Compact Disc specification. The Lead-out Area of the first Session has a length of 1 minute and 30 seconds; the Lead-out Area of a second or higher Session has a length of 30 seconds.

The last possible start time of a Lead-out is encoded in ATIP (see chapter 4.4).

5.7.1.1 ATIP/Subcode synchronization

In the Lead-out Area the Subcode-Q Absolute Time is identical to the ATIP time-code .

This page is intentionally left blank

6. EFM Modulation system

See ISO 10149 chapter 14 – 19 and Annex D.

7. CIRC Error correction system

. See ISO 10149 chapter 14 – 19 and Annex C.

8. Control and display system

See ISO 10149 chapter 14 – 19.

9. Audio specification

See Red Book pages 1 and 1a.

10. Digital data structure

See ISO 10149 chapter 14 – 19.

This page is intentionally left blank

11. Multisession and Hybrid disc

11.1 Introduction and Definitions

An area on the disc consisting of a Lead-in Area, a Program Area and a Lead-out Area is called a **Session**.

If a disc contains or can contain more than one Session then this disc is called a **Multisession disc**.

A **Hybrid disc** is a Multisession disc of which the first Session is a Mastered Session. (see Figure 12-17)

A Session is finalized if the Program Area is fully recorded and the Lead-in and Lead-out Areas of the Session are recorded.

If a disc leaves the recorder then all Sessions except the last one must be finalized.

The last recorded Session on a disc can be designated as the "Final Session" (see chapter 5.5.2), in this case the recording of additional Sessions is prohibited.

A Multisession CD-RW disc shall be recorded according to the rules for CD-R (CD-WO) in the "Multisession Compact Disc" specification, unless specified otherwise in this document.

11.2 PCA1, PCA2 and PMA

The PCA1, PCA2 and the PMA of a Multisession disc are according to the definitions in the chapters 5.3 and 5.4 of this document.

If a disc leaves the recorder then the PMA must contain the actual status of the data of all Tracks of all Sessions on that disc.

11.3 Lead-in Areas

See "Multisession Compact Disc Specification" chapter III.2.

Exception: Mode 5 must be present in the Lead-in Area of all sessions of a CD-RW disc, including the final session (see chapter 5.5 of this document).

11.4 Program Areas

See "Multisession Compact Disc Specification" chapter III.3.

11.5 Lead-out Areas

See "Multisession Compact Disc Specification" chapter III.4.

11.6 Data Retrieval Structure

See "Multisession Compact Disc Specification" chapter IV.

11.7 Hybrid disc: disc characteristics

The recordable parts of a hybrid disc must fulfil the specifications described in chapter 2.2: the unrecorded disc.

The recorded as well as the mastered parts of a hybrid disc must fulfil the specifications described in chapter 2.3: The Recorded Disc.

However: the specifications concerning max. variation of R_{top} and max. variation of push-pull ($\pm 15\%$, see Red Book page 7) are allowed to be fulfilled for the recorded and the mastered parts separately.

This page is intentionally left blank

12. Figures and Tables

- Figure 12-1 Layout of the Unrecorded disc
- Figure 12-2 Example of the layout of a Partially Recorded disc with one Session
- Figure 12-3 Example of the layout of a Finalized disc with one Session
- Figure 12-4 Operating conditions
- Figure 12-5 Maximum allowed time errors versus frequency spectrum.
- Figure 12-6 ATIP versus disc diameters
- Figure 12-7 Organization of the PCA1, PMA and Lead-In Area
- Figure 12-8 Organization of the PCA2 area in the Additional Capacity & Lead out Area
- Figure 12-9 Synchronization rules
- Figure 12-10 General linking rules
- Figure 12-11 Linking rules for audio & data
- Figure 12-12 Program Memory Area (example 1)
- Figure 12-13 Program Memory Area (example 2)
- Figure 12-14 Table of Contents in the Lead-in Area of an Audio disc
- Figure 12-15 Table of Contents in the first Lead-in Area of a Multisession Data disc
- Figure 12-16 The User Data Field in the Track Descriptor Block of Data Track 4 (Mode=1)
- Figure 12-17 Example of the layout of a Multisession disc
- Figure 12-18 Details of the centre hole, clamping and stacking ring areas
- Figure 12-19 Outer Rim Height detail at outer diameter of the disc
- Figure 12-20 Allowed Outer Rim Height values in relation with the substrate thickness

This page is intentionally left blank

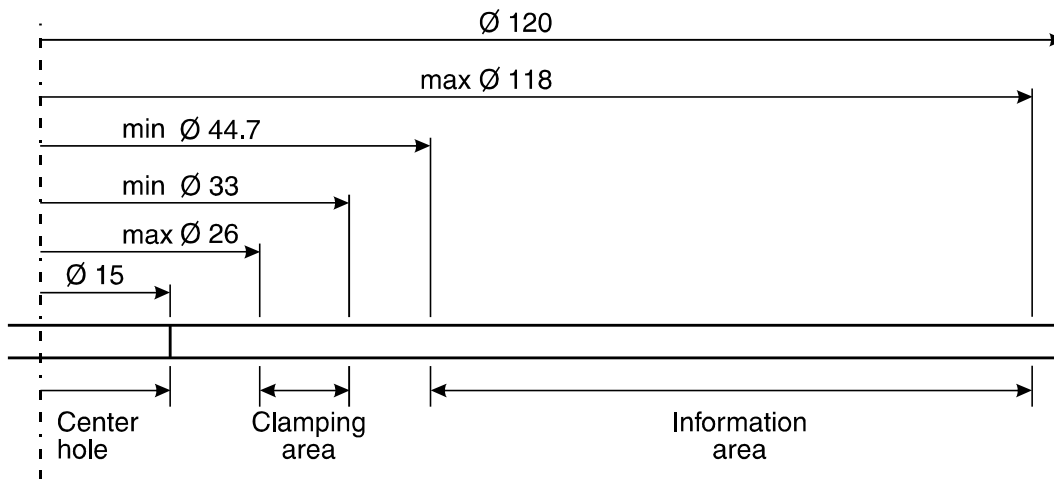

Figure 12-1 Layout of the Unrecorded disc

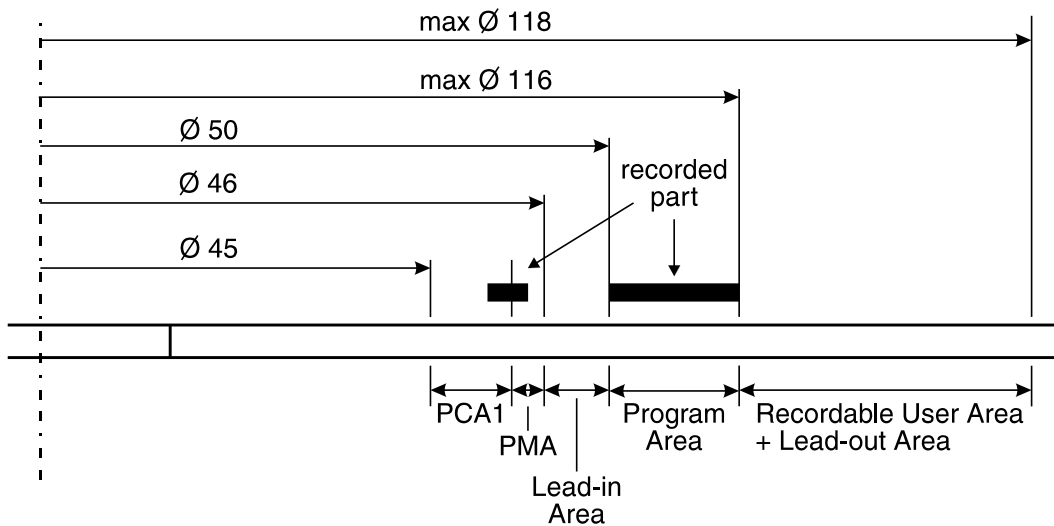

Figure 12-2 Example of the layout of a Partially Recorded disc with one Session

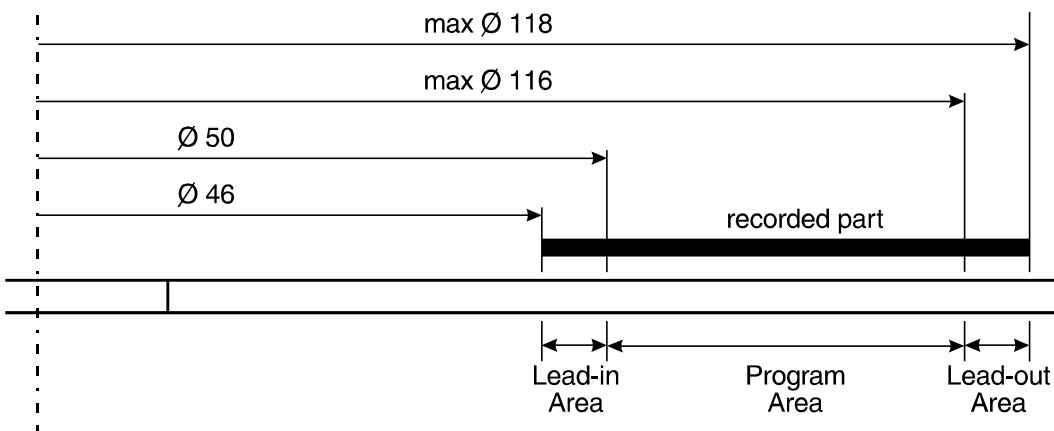

Figure 12-3 Example of the layout of a Finalized disc with one Session

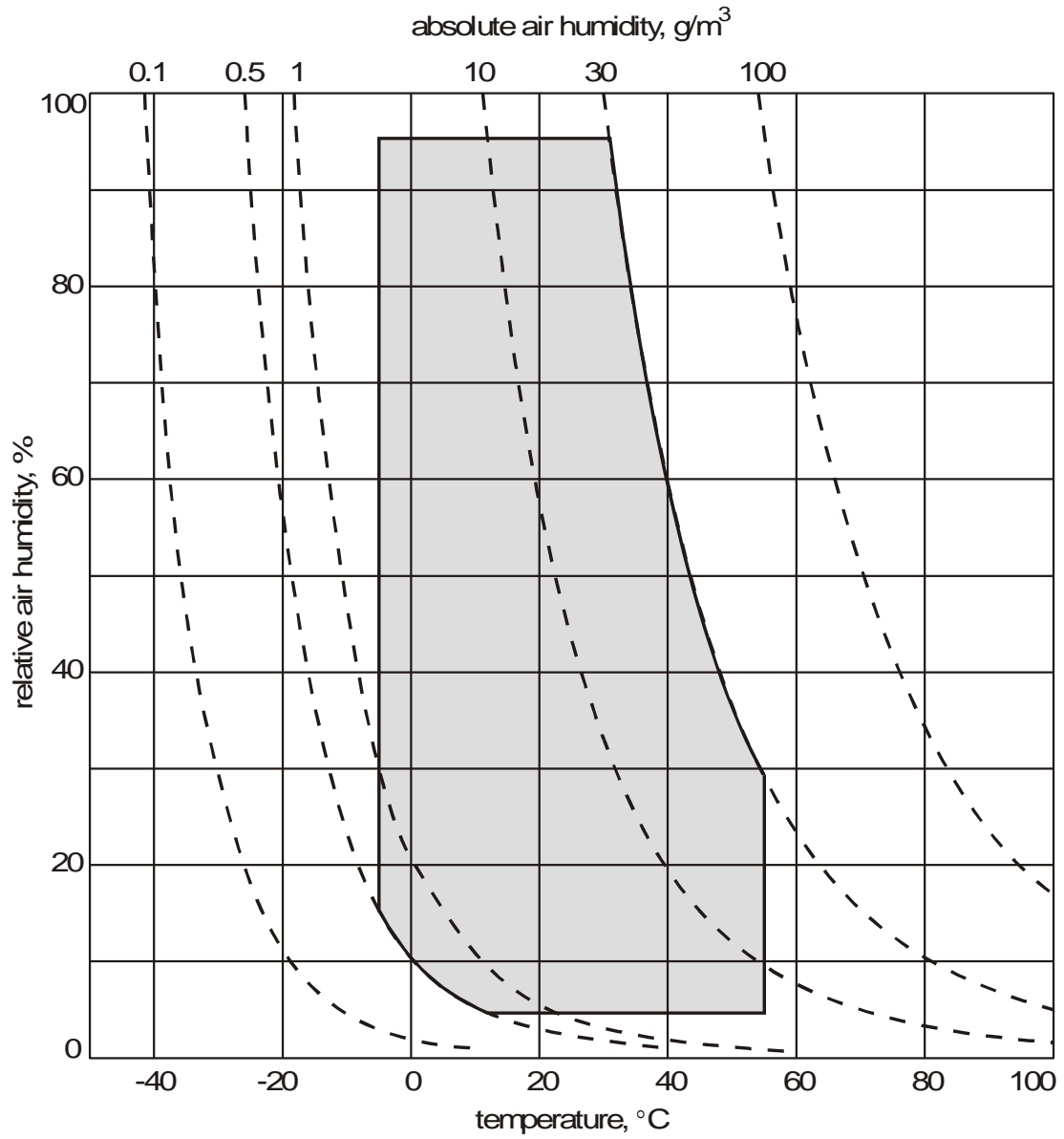

Figure 12-4 Operating conditions

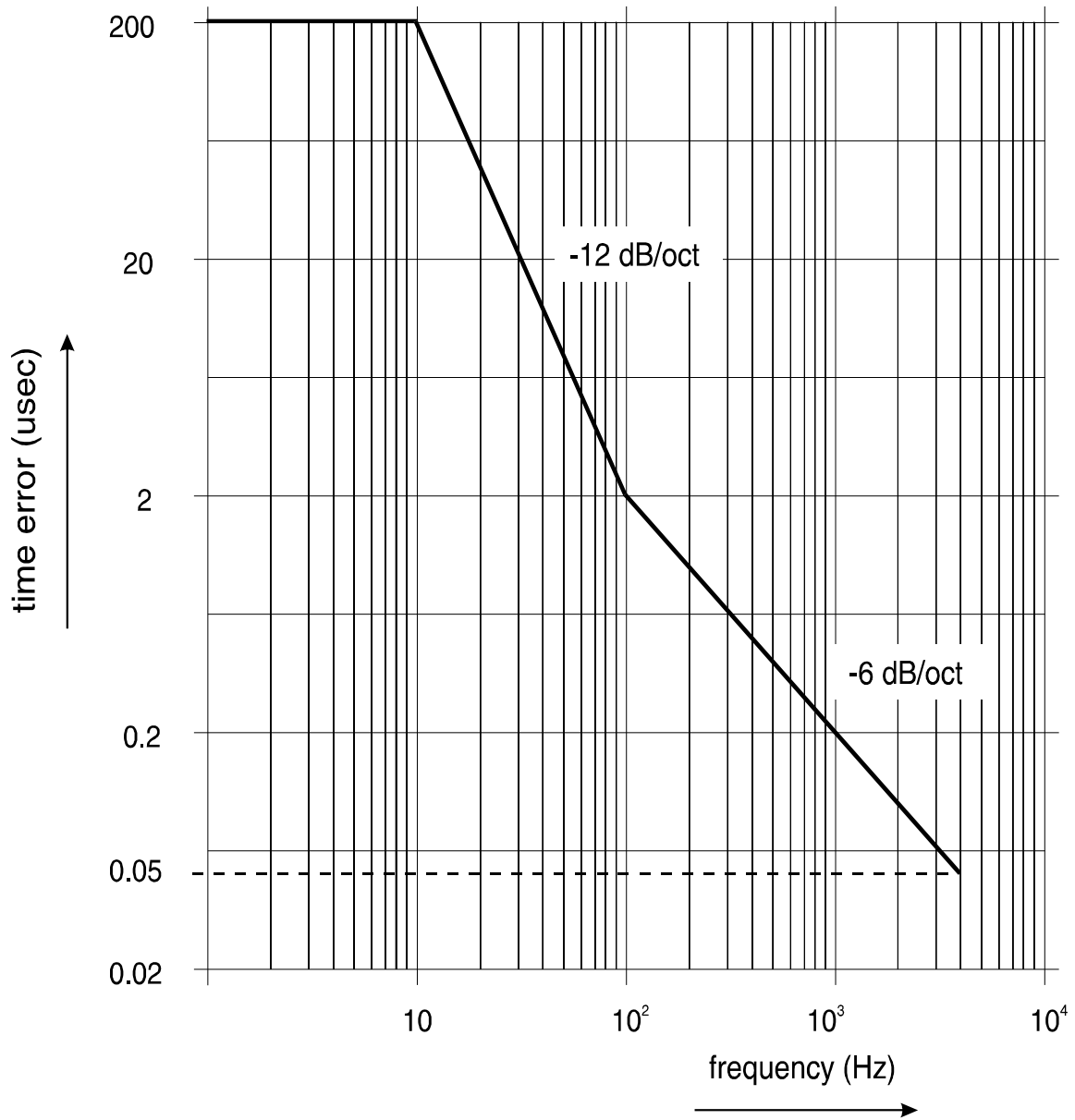
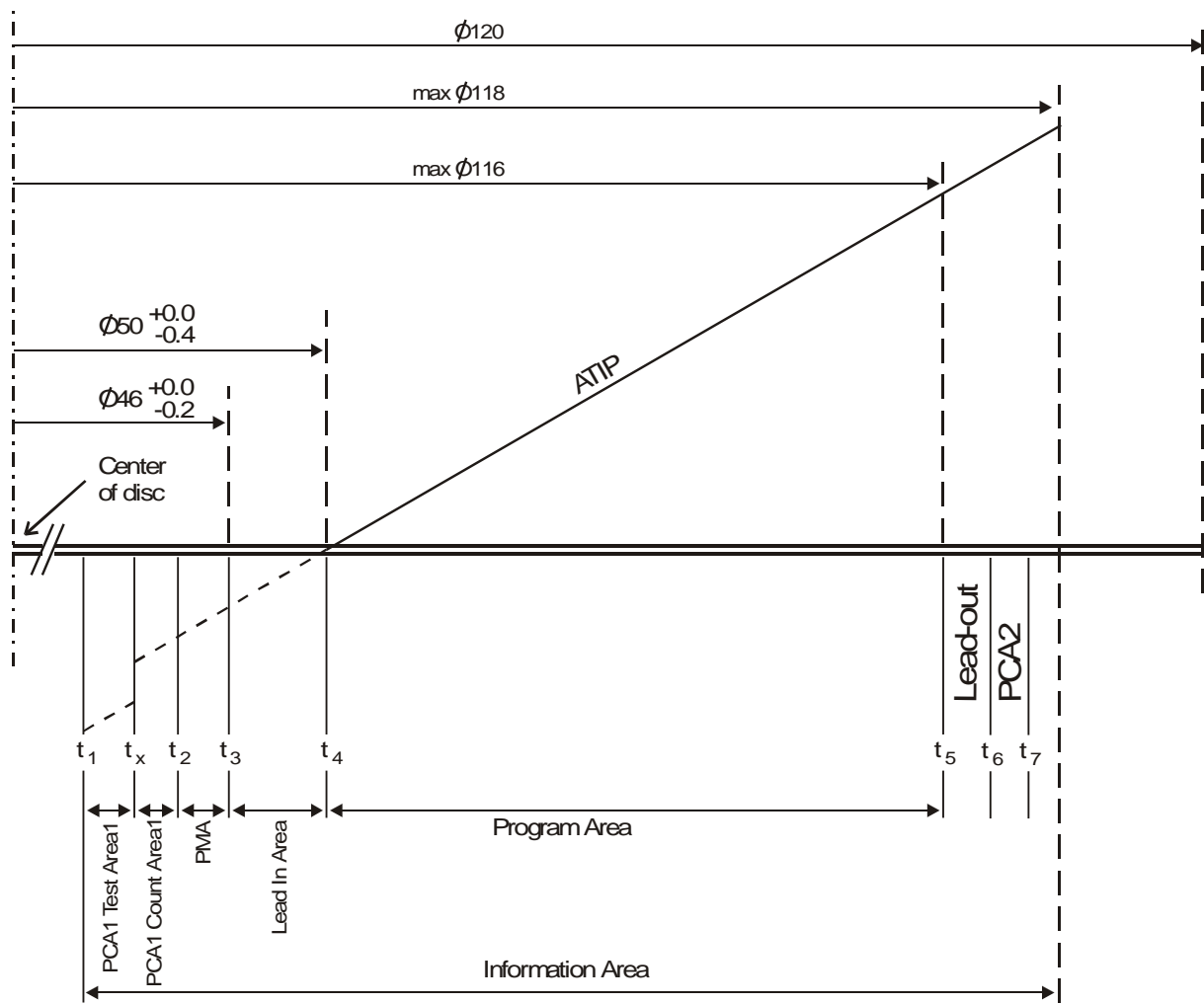

Figure 12-5 Maximum allowed time errors versus frequency spectrum.

CD-RW System Description

Chapter 12 Figures and Tables



t_1 = Start time PCA1 = t_3 - 01:05:65

At t_x the ATIP time code jumps from t_3 - 00:45:26 to t_3 - 00:15:25. This jump of 30 seconds means that the time codes ranging from t_3 - 00:45:25 to t_3 - 00:15:26 have been skipped (see also Figure 12-7).

t_2 = Start time PMA = t_3 - 00:13:25
 t_3 = Start time Lead In Area = encoded in ATIP
 t_4 = End time Lead In Area = 99:59:74
 Start time Program Area = 00:00:00
 t_5 = Last possible start time Lead Out Area = encoded in ATIP
 t_6 = Start of PCA2 = t_5 + 00:30:00
 t_7 = End of PCA2 = t_6 + 00:22:40

Figure 12-6 ATIP versus disc diameters

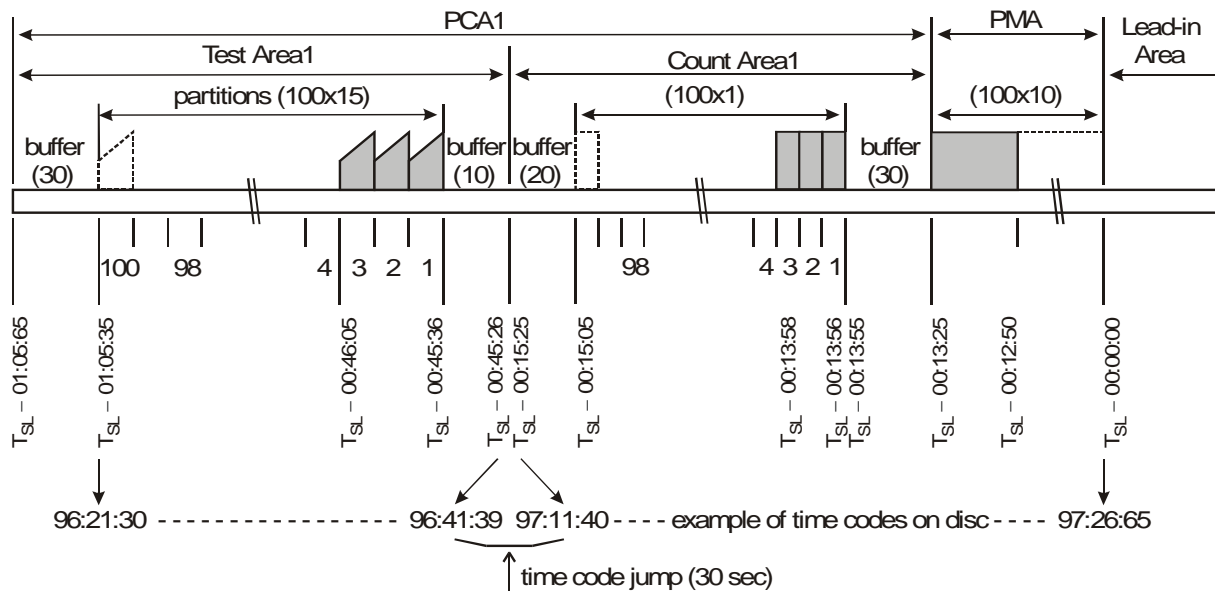

Figure 12-7 Organization of the PCA1, PMA and Lead-In Area

- * The disc is an incremental, partially recorded CD-RW disc.
- * T_{SL}= start time of the Lead-In Area, as encoded in ATIP.
- * The hatched area's are recorded parts of the disc.

In the **Program Area** of this disc there are:

- Track 1,2 and 3 (recorded uninterrupted, e.g. recorded on recorder A).
- Track 4 (e.g. recorded on recorder B).
- Track 5 and 6 (recorded uninterrupted, e.g. recorded on recorder C).

In the **Power Calibration Area 1 (PCA1)** of this disc there are:

- In the Test Area1: recorded data according to Optimum Power Control (OPC) procedure in partition 1 up to and including 3.
- In the Count Area1: recorded EFM data in partition 1 up to and including 3.

In the **Program Memory Area (PMA)** of this disc there are:

- 50 ATIP frames recorded: Disc Identification (first 10 frames) and track data of Track 1 to 6 (last 40 frames).

In the **Lead-In Area** of this disc there are:

- no data recorded, because disc is not yet finalized (see chapter 5.5.2).

CD-RW System Description

Chapter 12
Figures and Tables

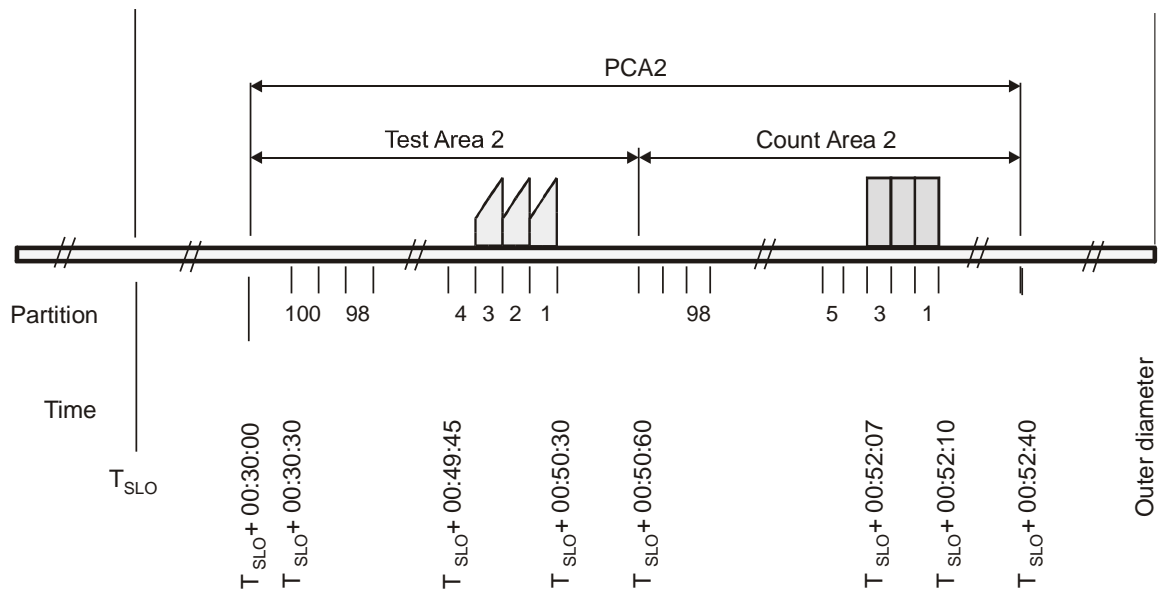

SLO = Start time last possible Lead-out Area

Figure 12-8 Organization of the PCA2 area in the Additional Capacity & Lead out Area

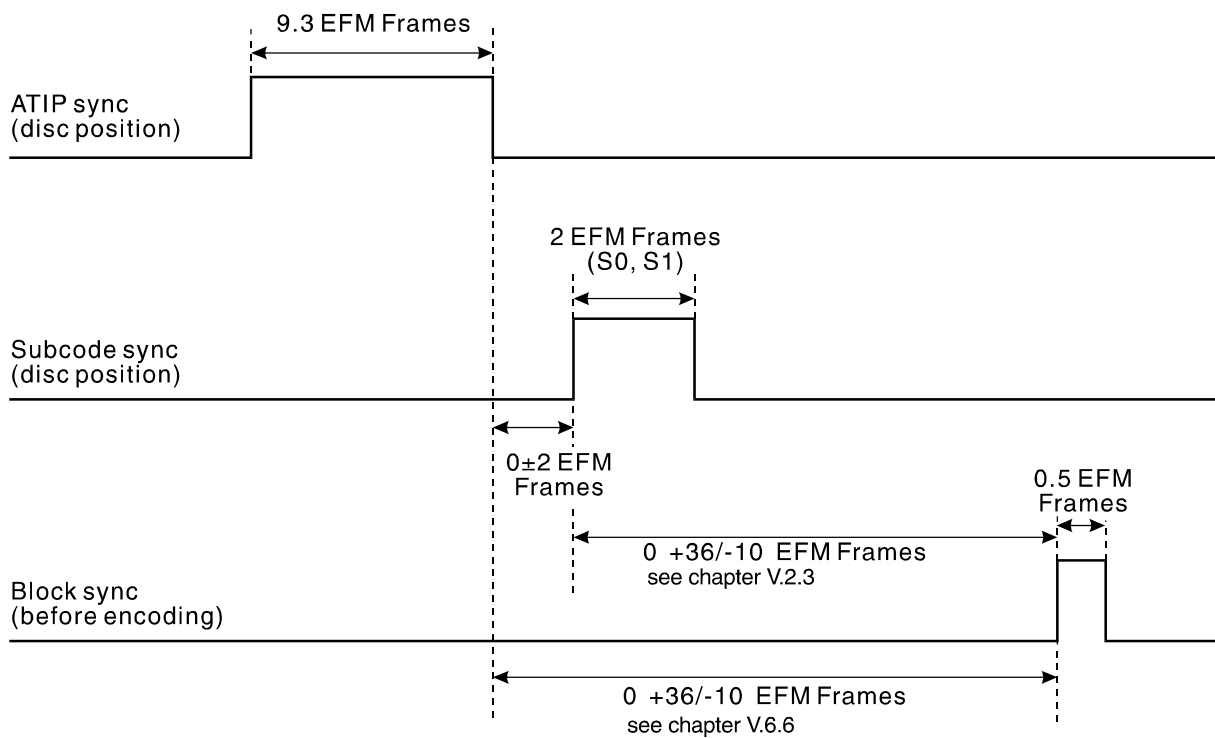

Figure 12-9 Synchronization rules

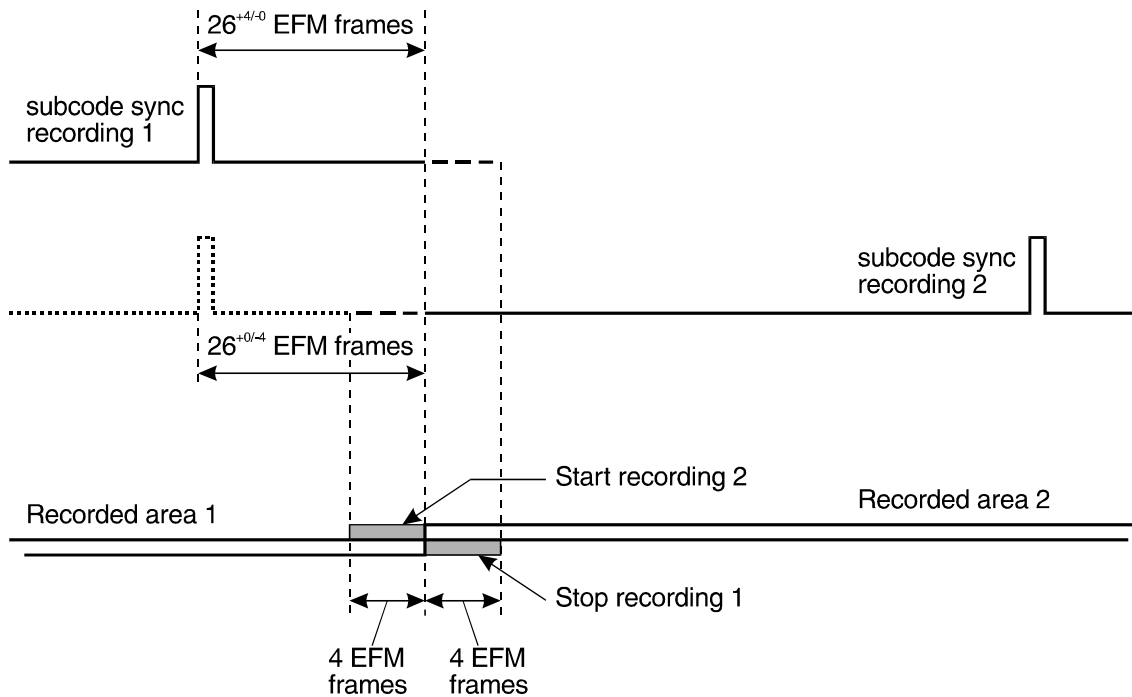
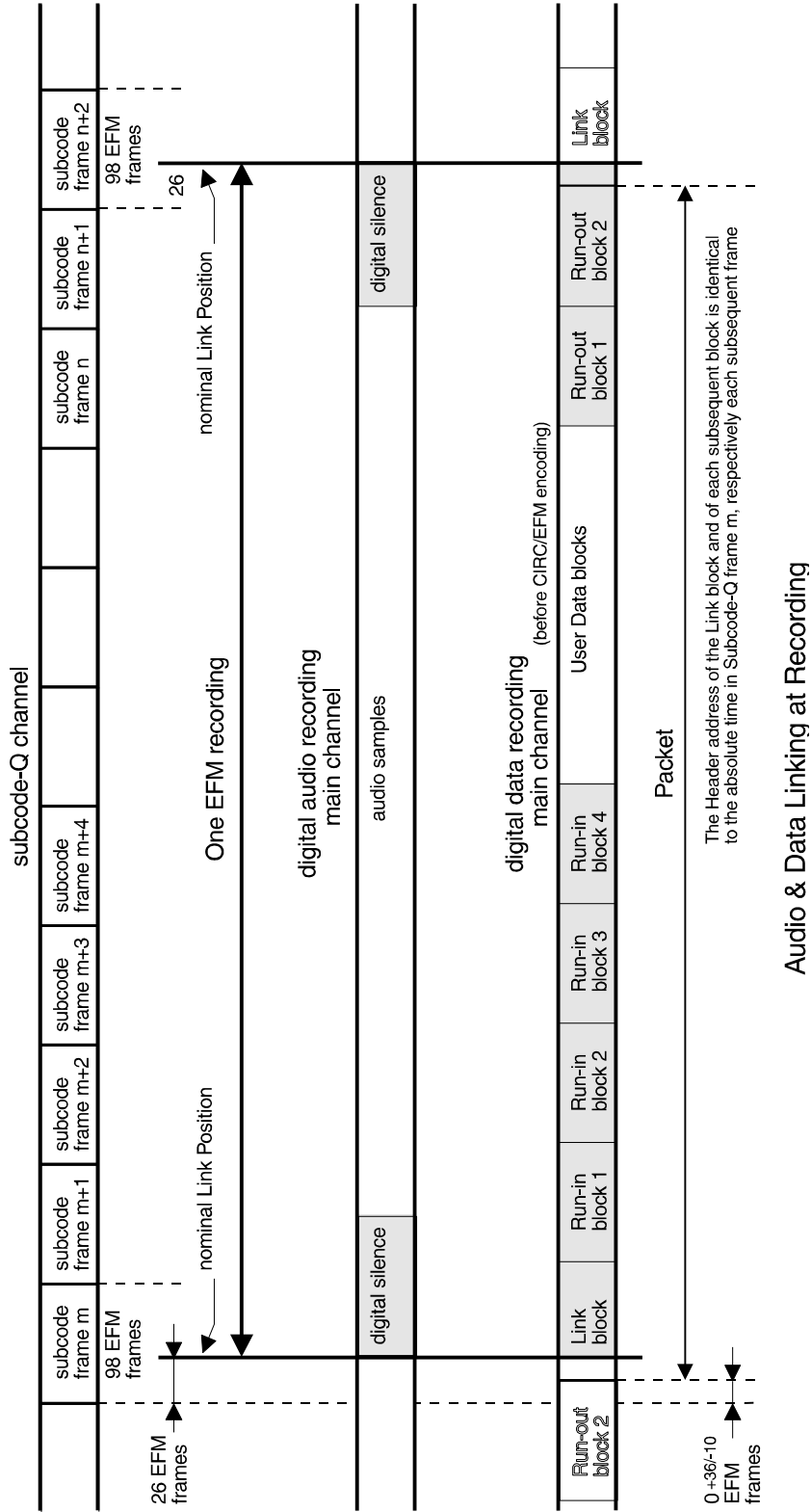

Figure 12-10 General linking rules



Audio & Data Linking at Recording

Figure 12-11 Linking rules for audio & data

Frame Number	CONTROL & ADR	TNO	POINT	MIN	SEC	FRM	ZERO	PMIN	PSEC	PFRM
1	02	00	00	20	15	14	00	00	00	00
2	02	00	00	20	15	14	01	00	00	00
3	02	00	00	20	15	14	02	00	00	00
4	02	00	00	20	15	14	03	00	00	00
5	02	00	00	20	15	14	04	00	00	00
6	02	00	00	20	15	14	05	00	00	00
7	02	00	00	20	15	14	06	00	00	00
8	02	00	00	20	15	14	07	00	00	00
9	02	00	00	20	15	14	08	00	00	00
10	02	00	00	20	15	14	09	00	00	00
11	01	00	01	05	45	67	00	00	02	01
12	01	00	01	05	45	67	01	00	02	01
13	01	00	01	05	45	67	02	00	02	01
14	01	00	01	05	45	67	03	00	02	01
15	01	00	01	05	45	67	04	00	02	01
16	01	00	02	12	01	09	05	05	45	67
17	01	00	02	12	01	09	06	05	45	67
18	01	00	02	12	01	09	07	05	45	67
19	01	00	02	12	01	09	08	05	45	67
20	01	00	02	12	01	09	09	05	45	67
21	01	00	03	30	17	42	00	12	04	09
22	01	00	03	30	17	42	01	12	04	09
23	01	00	03	30	17	42	02	12	04	09
24	01	00	03	30	17	42	03	12	04	09
25	01	00	03	30	17	42	04	12	04	09
26	01	00	04	37	50	18	05	30	19	52
27	01	00	04	37	50	18	06	30	19	52
28	01	00	04	37	50	18	07	30	19	52
29	01	00	04	37	50	18	08	30	19	52
30	01	00	04	37	50	18	09	30	19	52
31	etc. : unrecorded									

Figure 12-12 Program Memory Area (example 1)

Example of encoding of the PMA of CD-RW disc number 201514, with 4 Audio Tacks in the Program Area.

* frame 1 to 10: the Disc Identification is noted.
In this case, this Item has been recorded separately, so this Item is repeated 10 times (uneven number of Items, see chapter 5.4.2).

* frame 11 to 30: the start and stop times of Track 1 to 4 are noted.

As there is no Skip information, all four Tracks will be played back completely.

CD-RW System Description

Chapter 12 Figures and Tables

Frame Number	CONTROL & ADR	TNO	POINT	MIN	SEC	FRM	ZERO	PMIN	PSEC	PFRM
1	02	00	00	20	15	14	00	00	00	00
..
10	02	00	00	20	15	14	09	00	00	00
11	01	00	01	05	45	67	00	00	02	01
12	01	00	01	05	45	67	01	00	02	01
13	01	00	01	05	45	67	02	00	02	01
14	01	00	01	05	45	67	03	00	02	01
15	01	00	01	05	45	67	04	00	02	01
16	01	00	02	12	01	09	05	05	45	67
17	01	00	02	12	01	09	06	05	45	67
18	01	00	02	12	01	09	07	05	45	67
19	01	00	02	12	01	09	08	05	45	67
20	01	00	02	12	01	09	09	05	45	67
21	01	00	03	30	17	42	00	12	04	09
22	01	00	03	30	17	42	01	12	04	09
23	01	00	03	30	17	42	02	12	04	09
24	01	00	03	30	17	42	03	12	04	09
25	01	00	03	30	17	42	04	12	04	09
26	01	00	04	37	50	18	05	30	19	52
27	01	00	04	37	50	18	06	30	19	52
28	01	00	04	37	50	18	07	30	19	52
29	01	00	04	37	50	18	08	30	19	52
30	01	00	04	37	50	18	09	30	19	52
31	03	00	01	02	03	04	00	00	00	00
32	03	00	01	02	03	04	01	00	00	00
33	03	00	01	02	03	04	02	00	00	00
34	03	00	01	02	03	04	03	00	00	00
35	03	00	01	02	03	04	04	00	00	00
36	05	00	01	05	45	67	05	05	42	67
37	05	00	01	05	45	67	06	05	42	67
38	05	00	01	05	45	67	07	05	42	67
39	05	00	01	05	45	67	08	05	42	67
40	05	00	01	05	45	67	09	05	42	67
41	01	00	05	42	16	32	00	37	50	18
42	01	00	05	42	16	32	01	37	50	18
43	01	00	05	42	16	32	02	37	50	18
44	01	00	05	42	16	32	03	37	50	18
45	01	00	05	42	16	32	04	37	50	18
46	01	00	05	42	16	32	05	37	50	18
47	01	00	05	42	16	32	06	37	50	18
48	01	00	05	42	16	32	07	37	50	18
49	01	00	05	42	16	32	08	37	50	18
50	01	00	05	42	16	32	09	37	50	18
51	etc. : unrecorded									

Figure 12-13 Program Memory Area (example 2)

Example of encoding of the PMA of CD-RW disc number 201514, with 5 Audio Tracks in the Program Area.

* frame 1 to 30: see Figure 12-12

* frame 31 to 35: Tracks 2, 3 and 4 are noted to be skipped.

* frame 36 to 40: Time Interval number 1 is noted to be skipped.

* frame 41 to 50: start and stop time of Track 5 is noted.

As a result, Track 1 and 5 will be played back. Track 2, 3 and 4 and the last three seconds of Track 1 will be skipped.

Frame Number	CONTROL & ADR	TNO	POINT	MIN	SEC	FRM	ZERO	PMIN	PSEC	PFRM
n	01	00	A0	absolute time			00	01	00	00
n+1	01	00	A0	absolute time			00	01	00	00
n+2	01	00	A0	absolute time			00	01	00	00
n+3	05	00	B1	00	00	00	00	02	01	00
n+4	05	00	B1	00	00	00	00	02	01	00
n+5	05	00	B1	00	00	00	00	02	01	00
n+6	01	00	A1	absolute time			00	05	00	00
..
n+9	05	00	B2	02	00	00	00	00	00	00
..
n+12	01	00	A2	absolute time			00	42	16	32
..
n+15	05	00	01	05	45	67	00	05	42	67
..
n+18	01	00	01	absolute time			00	00	02	01
..
n+21	05	00	02	42	16	32	00	40	00	00
..
n+24	01	00	02	absolute time			00	05	45	67
..
n+27	05	00	C0	C6	00	9C	00	97	35	00
..
n+30	01	00	03	absolute time			00	12	04	09
..
n+33	05	00	C1	48	8C	70	00	00	00	00
..
n+36	01	00	04	absolute time			00	30	19	52
..
n+39	05	00	B0	FF	FF	FF	07	63	00	00
..
n+42	01	00	05	absolute time			00	37	50	18
..
n+45	05	00	B1	00	00	00	00	02	01	00
..
n+48	01	00	A0	absolute time			00	01	00	00
..
n+51	05	00	B2	02	00	00	00	00	00	00
..
n+54	01	00	A1	absolute time			00	05	00	00
..
n+57	etc.

Figure 12-14 Table of Contents in the Lead-in Area of an Audio disc

Example of encoding of the TOC for a CD-RW disc with an audio session containing 5 Tracks in the Program Area. Track 2 and two Time Intervals should be skipped at play back.

The Lead-in contains Additional information 1.

- frame n to n+44: one complete encoding of Mode-1 (ADR=1), alternated with Mode-5 encoding.
- frame n+3 to n+41: one complete encoding of Mode-5 (ADR=5), alternated with Mode-1 encoding.

CD-RW System Description

Frame Number	CONTROL & ADR	TNO	POINT	MIN	SEC	FRM	ZERO	PMIN	PSEC	PFRM
n	01	00	A0	absolute time			00	01	00	00
n+1	01	00	A0	absolute time			00	01	00	00
n+2	01	00	A0	absolute time			00	01	00	00
n+3	05	00	B0	22	30	00	03	63	00	00
n+4	05	00	B0	22	30	00	03	63	00	00
n+5	05	00	B0	22	30	00	03	63	00	00
n+6	01	00	A1	absolute time			00	01	00	00
..
n+9	05	00	C0	C6	00	9C	00	97	35	00
..
n+12	01	00	A2	absolute time			00	20	00	00
..
n+15	05	00	C1	48	8C	70	00	00	00	00
..
n+18	01	00	01	absolute time			00	00	02	00
..
n+21	05	00	B0	22	30	00	03	63	00	00
..
n+24	01	00	A0	absolute time			00	01	00	00
..
n+27	etc.

Figure 12-15 Table of Contents in the first Lead-in Area of a Multisession Data disc

Example of encoding of the TOC for a CD-RW disc with one finalized data session containing 1 Track in the first Program Area. The start time of the second Program Area is given in POINT=B0. The Lead-in contains Additional information 1.

- frame n to n+20: one complete encoding of Mode-1 (ADR=1), alternated with Mode-5 encoding.
- frame n+3 to n+17: one complete encoding of Mode-5 (ADR=5), alternated with Mode-1 encoding.

	Byte	Contents
Track Descriptor Table	0	54
	1	44
	2	49
	3	01
	4	50
	5	01
	6	04
	7	04
Track Descriptor Unit	8	04
	9	91
	10	00
	11	00
	12	32
	13	00
	14	00
	15	00
	16	00
	17	00
	18	00
	19	00
	20	00
	21	00
	22	00
	23	00
non-used bytes	24	00
	..	00
	..	00
	2047	00

Figure 12-16 The User Data Field in the Track Descriptor Block of Data Track 4 (Mode=1)

- * Byte number 0 to 7 is the Track Descriptor Table of Track 4.
- * Byte number 8 to 23 is the Track Descriptor Unit of Track 4.
- * The Pre Gap is 2 seconds (150 blocks) long.
- * Track 4 is Incremental written with a fixed Packet Size of 32 User Data Blocks.

CD-RW System Description

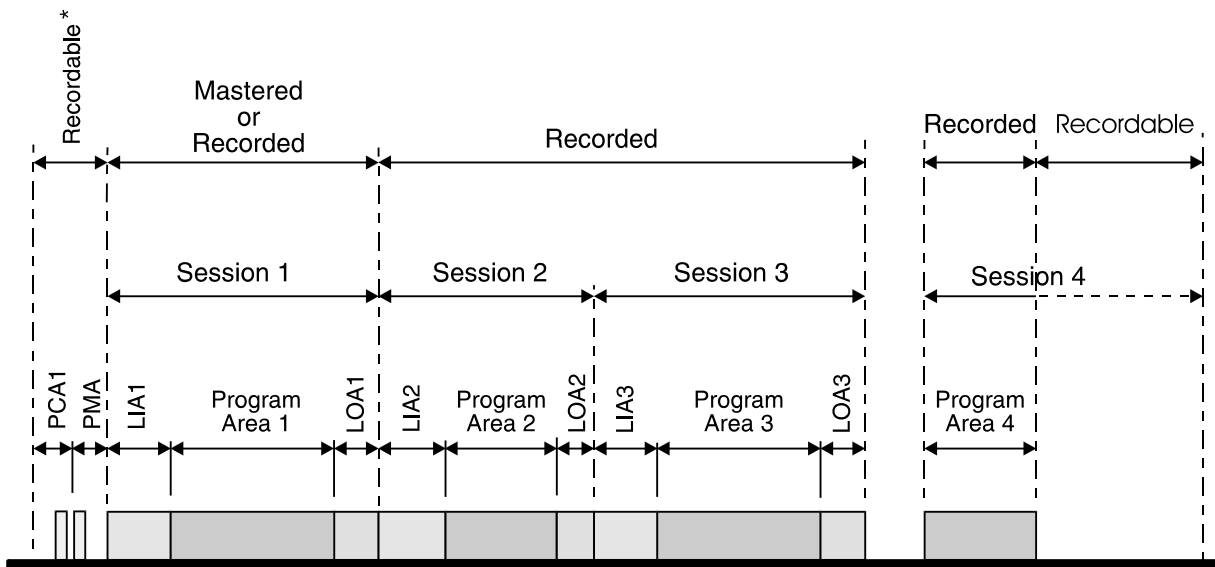

Figure 12-17 Example of the layout of a Multisession disc

Notes:

LIA = Lead-In Area

LOA = Lead-Out Area

- Both the PMA and the PCA1 in this example are partially recorded and recordable. If Session 1 is Mastered, then the PMA is partially mastered, recorded and recordable.
-

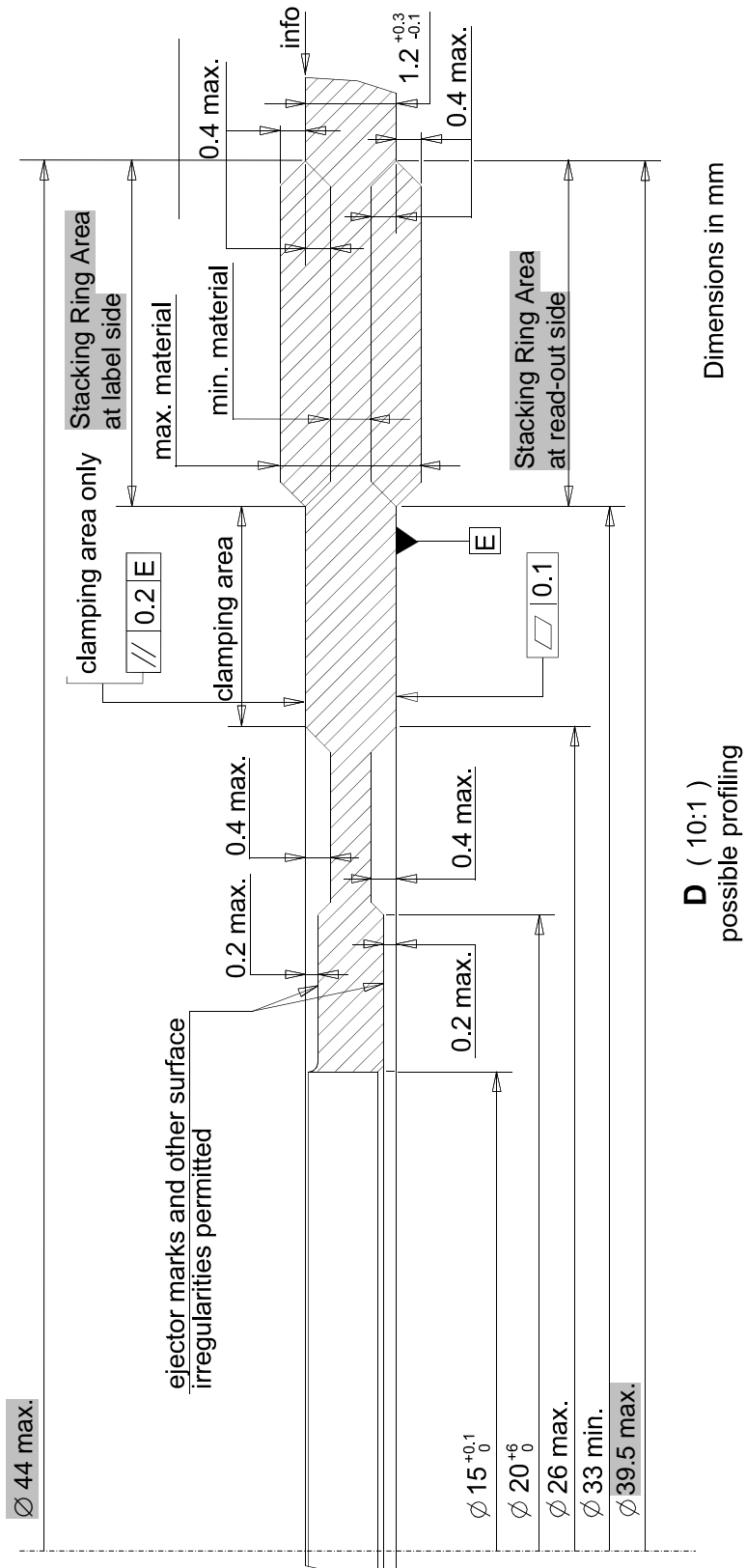

Dimensions in mm

D (10:1)
possible profiling

Figure 12-18 Details of the centre hole, clamping and stacking ring areas

Values and definitions in Figure 12-18 that are highlighted by grey background differ from the values of the latest version of the Red Book.

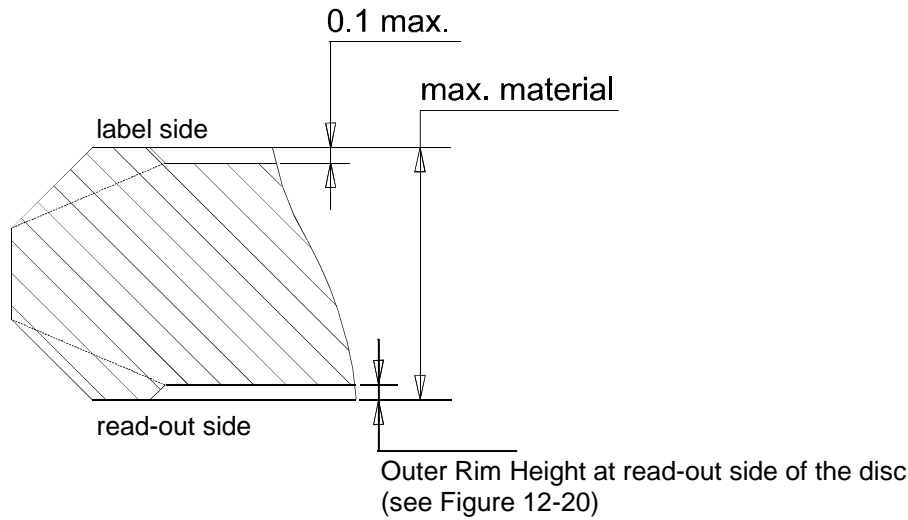

Figure 12-19 Outer Rim Height detail at outer diameter of the disc

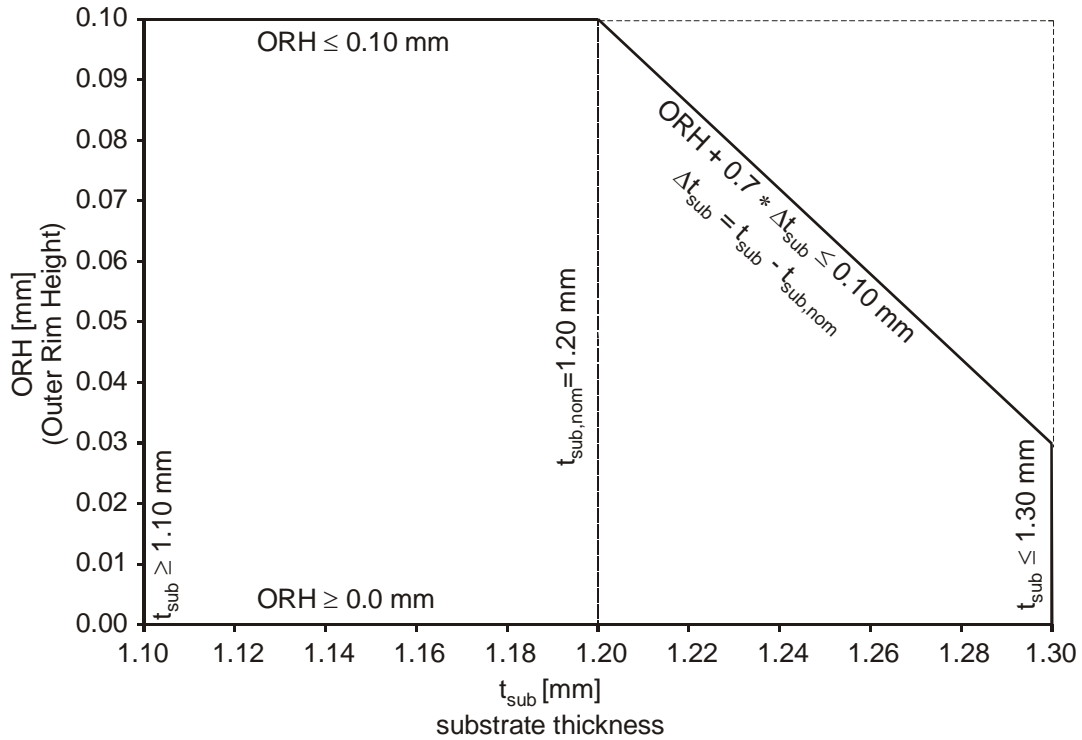

Figure 12-20 Allowed Outer Rim Height values in relation with the substrate thickness

At the outer diameter of the disc a rim is allowed, see Figure 12-19, both at the label side and the read-out side of the disc. The height of the outer rim at the label side of the disc is max. 0.1 mm (identical to the Red Book). The Outer Rim Height (ORH) at the read-out side of the disc is restricted as follows:

- ORH limit is 0.10 when $1.10 \leq t_{sub} \leq 1.20$ mm,
- ORH limit is $0.10 - 0.7 * \Delta t_{sub}$ when $1.20 \leq t_{sub} \leq 1.30$ mm,

as indicated in Figure 12-20, where t_{sub} is the substrate thickness of the disc at the data area and $\Delta t_{sub} = t_{sub} - t_{sub,nom}$.

13. Attachments

Recommendations and clarifications

- Attachment 1: Principles of operation
- Attachment 2: HF Modulation
- Attachment 3: Optimum Power Control
- Attachment 4: Environment: operating and storage conditions
- Attachment 5: Push Pull magnitude and the Normalized Push Pull Ratio
- Attachment 6: Measurement of the groove wobble amplitude
- Attachment 7: The use of the Pre-Gap
- Attachment 8: The use of addressing Method 1 and Method 2
- Attachment 9: Serial Copy Management System (SCMS)
- Attachment 10: Write-strategy optimization

This page is intentionally left blank

Attachment 1 (informative)**13.1 Principles of operation****13.1.1 Recorded information**

In the Information Area, the CD-RW disc contains a spiral shaped groove. This groove is not a perfect spiral, but is wobbled in order to produce motor control and timing information. The sensitive layer is applied to the grooved side of the substrate.

Recording takes place in the groove by locally heating the sensitive layer with a laser spot. The sensitive layer is rewritable which means that previously recorded information can be overwritten. During recording the laser power is modulated according to the Write-strategy. The parts of the disc that show a low reflection ($\ll R_{top}$) after recording are called marks, the areas between the marks are erased. The erased areas have a reflection level equal to R_{top} . The encoded Audio or Data information is stored in the lengths of these marks and lengths of the distances between them. These lengths only can take discrete values.

During read-out of the disc, the scanning light spot is diffracted and absorbed by the recorded marks in the sensitive layer. The optical power that is diffracted back into the objective lens, is modulated according to the encoded Audio or Data information. The modulated photo current is called the High Frequency (HF) signal.

The requirements for a recorded CD-RW disc are the same as the requirements for a conventional CD disc (see Red Book) with the exception of R_{top} , Push-Pull and I_{11}/I_{top} , see chapter 2.3. Therefore the recorded CD-RW disc can only be read-out on CD-RW enabled CD-players.

13.1.2 Tracking Information

An off-track position of the scanning spot results in a diffraction pattern that is asymmetrical in the radial direction of the disc. Subtraction of the powers diffracted into the two halves of the aperture of the objective lens yields a servo signal for track following.

13.1.3 Reading at different speeds

At higher read-out speeds, it may be necessary to increase the read power in order to improve read-out margins. Too high read powers however will degrade the read stability.

13.1.4 Physical Erase

By writing with a continuous laser power of about PEO, the overwritten track will be left in the high-reflective state: all previously recorded marks are erased and the erased area is in the unrecorded state again. The maximum number of DOW cycles may be reduced by this procedure, therefore it is recommended to use this erase method only for erasing the PCA1 and PCA2 areas, where the presence of previously written marks could disturb the OPC procedure.

13.1.5 Logical Erase

If an area on the disc (except the PCA1 and PCA2) has to be erased, it is recommended to overwrite the area with an EFM signal with "zero content"². This will cause less reduction of the maximum number of DOW cycles.

A logically erased area is equivalent to an unrecorded (or physically erased) area and has to be treated in the same way. The control field in the PMA entry of an erased Track may be different from the control field of that Track in the Program Area.

If a Lead-in Area of a Session is logically erased, then that Session is a non-finalized Session. Only the last Session on a disc can be a non-finalized Session, of which the end address is not yet known. As a consequence of this, it is not possible to indicate the start address of a possible following Session and MIN, SEC, FRAME of POINT=B0 shall be set to 'FF, FF, FF'. After the non-finalized Session has been recorded completely, it can be finalized again: its Lead-in Area is overwritten and POINT=B0 can indicate the start address of a possible new Session.

13.1.6 Formatting

If a disc is going to be used for data recording with fixed packets, it can be advantageous to apply a formatting function. Formatting means that the disc is overwritten with a Lead-in Area containing a TOC with all Track information, a Program Area containing the Track(s) with Subcode-Q mode 1 and "empty" packets of the required size, and a Lead-out Area.

If a disc is partly formatted and the area after the Lead-out Area of the formatted part is going to be used for another Session, then this outer part of the disc shall be logically erased.

An advantage of this method is that the disc, after formatting, is fully "randomly" re-writable and is continuously in the finalized state.

	logically erased	formatted
Lead-in Area	subcode Q = zero content no TOC	subcode Q = mode 1 & mode 5 TOC recorded
Program Area	main channel = zero content subcode channel = zero content track structure = undefined	main channel = any content subcode channel = normal content track structure = according to TOC
Lead-out Area	not present	recorded at end of disc

Figure 0-1 Main differences of logically erased and formatted discs

² "Zero content" means:

- Digital silence (for instance all '00' bytes) in case of Audio Tracks
- Empty sectors (for instance filled with all '00' bytes) in case of Data Tracks
- Subcode-Q mode 0 (different for PMA, Lead-in Area and Program Area)

Attachment 2 (informative)**13.2 HF Modulation****13.2.1 Dependency on Read Pick-up**

The modulation of the HF signal from the recorded CD-RW disc is more dependent on the read-out spot width than in conventional CD. Therefore, when a different read only pick up is used to read out the recorded CD-RW disc (other than the "Read Only pick-up (1)"), the HF modulation I_{11}/I_{top} can change as much as $\pm 10\%$. This means that the lower limit of the HF modulation can be 0.50 in some practical implementations.

13.2.2 Dependency on Recorder Pick-up

When a different recorder pick up is used than the one specified in chapter 2.1.2 for disc measurements, with an appropriate power setting and Write-strategy, the width of the recorded mark may be greater than that obtained using "Recorder optical pick-up (3)" for the same CD-RW disc. The broader marks will result in larger HF modulation values. To ensure good compatibility when using such a different recorder pick up, the following condition should be satisfied:

$$m_{11} < I_{11}/I_{top} < 1.2 * m_{11}.$$

remark 1:

$m_{11} = I_{11}/I_{top}$ under the test conditions specified in chapter 0.

Attachment 3 (informative)

13.3 Optimum Power Control

13.3.1 Optimum recording power

The optimum recording powers PWO and PEO (see chapter 0) depend on the disc, the recorder and the recording speed. The determination of values for **PWO,X and PEO,X for the actual disc/recorder combination at the actual recording speed X**, is called the **Optimum Power Control procedure (OPC procedure)**.

For a sensitive OPC procedure, the modulation versus power curve $m(PW)$ shall be determined in a power range with sufficient variation of the modulation as a function of the power (slope $\equiv \gamma = (dm/dPW)/(m/PW) \approx 0.5-2.0$). The OPC procedure determines for the actual disc/recorder combination and recording speed X, the value $P_{target,X}$ of the power for which $\gamma = \gamma_{target}$.

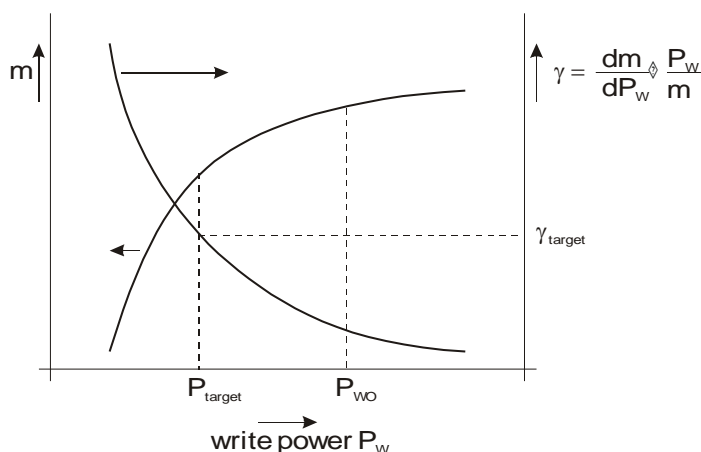

Figure 0-2 Modulation and Gamma versus Power function

To facilitate the OPC procedure, values are provided for γ_{target} , P_{ind} , ρ and ε for 3 different speeds, which are encoded as special/additional information in the ATIP during the Lead-in Area:

- γ_{target} (G1..G3, see chapter 0)
- $P_{ind,1T}$ (W1..W3, see chapter 4.4.1.1.)
- ρ_{1T} (P1..P3, see chapter 4.4.4.3)
- ε_{1T} (E1..E3, see chapter 0)

These values can be used as starting values in test recordings for the determination of the actual optimum values PWO and PEO.

The relevance of the parameters for determining PWO and PEO is shown in the following formulas and Figure 0-2 :

- $m = I_{11}/I_{top}$: the modulation amplitude of the HF signal
- $\gamma = (dm/dPW) / (m/PW)$: the normalized slope of the function $m(PW)$
- $P_{ind,X}$: indicated estimate for P_{target} at speed X from ATIP
- $P_{target,X} = PW(at \ \gamma_{target})$: the actual write power at $\gamma = \gamma_{target}$ at speed X
- ρ_X : the multiplication factor to obtain $P_{WO,X}$
- $P_{WO,X} = \rho_X * P_{target,X}$: the optimum recording power P_{WO} at speed X
- ε_X : the erase/write power ratio at speed X
- $P_{EO,X} = \varepsilon_X * P_{WO,X}$: the optimum erase power PEO at speed X

13.3.2 Mathematical model for the modulation versus power function

To minimize the influences of random measuring errors and noise, the modulation versus

power curve is approximated by the following function: $m(P_W) = m_{max} * (1 - \frac{P_{thr}}{P_W})$

with m_{max} = max modulation (saturation level) and P_{thr} = threshold power.

The γ value calculated from this approximation is: $\gamma(P_W) = \frac{P_{thr}}{P_W - P_{thr}}$

and thus P_{target} is: $P_{target} = P_{thr} * (1 + \frac{1}{\gamma_{target}})$

The function $f(P_W) = P_W * m(P_W)$ will result in a straight line: $P_W * m(P_W) = m_{max} * (P_W - P_{thr})$

By test recording random EFM data with different write powers P_{Wi} and $P_{Ei} = \epsilon * P_{Wi}$, the accompanying modulation values m_i are obtained.

By fitting the straight line $P_W * m(P_W) = m_{max} * (P_W - P_{thr})$ to several points (P_{Wi} , $m_i * P_{Wi}$), m_{max} and P_{thr} for these points can be determined easily (one should realize that due to the limited accuracy of the model, m_{max} can take values >1).

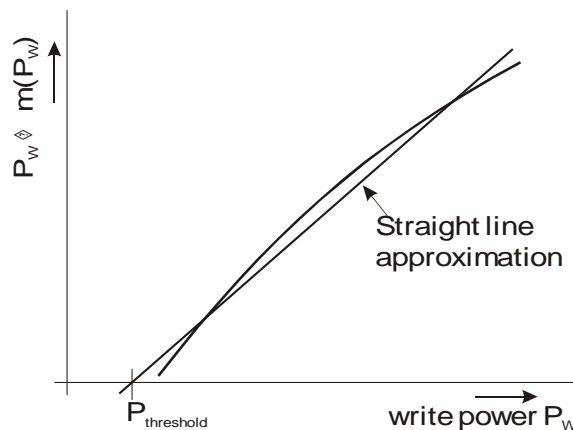

Figure 0-3 Modulation times Power versus Power function

13.3.3 Procedure for the determination of the OPC parameters for media

Media manufacturers first have to determine the optimum recording powers P_{W0} and P_{E0} for their media. This can be done by making test recordings with several combinations of P_W and P_E and measuring the resulting recorded parameters according to chapter 0. The recordings have to be made using a reference recorder with PU(3) and the measurements have to be performed on a reference player with PU(1)/PU(2) (see chapter 2.1.2).

After choosing the combination of $P_W = P_{W0}$ and $P_E = P_{E0}$, resulting in optimum recorded parameters, the ratio $\epsilon = P_{E0}/P_{W0}$ is fixed.

In the next step the parameters to be specified in the ATIP in the Lead-in area have to be determined. The media manufacturer shall make a choice for the indicated estimate of the target write power P_{ind} . The multiplication factor is: $\rho = P_{W0}/P_{ind}$.

Before determining the γ_{target} value according to the following procedure, the tracks to be used for the measurements shall be erased once by irradiating these tracks using only the P_E power ($P_E = \epsilon * \rho * P_{ind}$)

Procedure for determination of the γ_{target} value:

After writing random EFM data with different recording powers P_{Wi} ranging from $0.9 * P_{ind}$ to $1.1 * P_{ind}$, and $P_{Ei} = \epsilon * P_{Wi}$, the resulting modulations m_i are measured. Both the recording

and the measurement of m_i are performed on a reference recorder with PU(3) and at a laser wavelength of 786 nm and $T = 23\text{ }^{\circ}\text{C}$.

Next a straight line fit according to chapter 13.3.2 is made to the obtained measuring points and γ_{target} can be calculated:

$$\gamma_{\text{target}} = \frac{P_{\text{thr}}}{P_{\text{ind}} - P_{\text{thr}}}$$

remark 1:

Because probably not all recorded parameters can be optimized independently, it is up to the media manufacturer to decide about the optimum combination of recorded parameters for his media.

remark 2:

Because the measurement of the modulation becomes rather inaccurate at low values, the power ranges (and thus P_{ind}) should be chosen such that the modulation at the lowest power value is $> 30\%$.

remark 3:

It might be needed to do some tuning of P_{ind} , in order to get a measured γ_{target} value which best fits the targeted value chosen from the table specified in 0.

13.3.4 An example OPC procedure for recorders

By test recording random EFM data with different write powers P_{W_i} and $P_{E_i} = \varepsilon * P_{W_i}$, the accompanying modulation values m_i are obtained.

By fitting the straight line $P_W * m(P_W) = m_{\text{max}} * (P_W - P_{\text{thr}})$ to several points (P_{W_i} , $m_i * P_{W_i}$), m_{max} and P_{thr} for these points can be determined easily.

Now P_{target} for a specific power range can be calculated (see chapter 13.3.2) with the help of γ_{target} given in Additional Information 1 (see chapter 4.4.4).

Because the mathematical model is only a first order approximation, an interpolation or iteration procedure might be needed to come to a sufficiently accurate value of P_{target} .

The following interpolation procedure is given as an example:

- 2 center power values are chosen for a straight line fit:
 $P_{\text{fit},1} = 0.95 * P_{\text{ind}}$ and $P_{\text{fit},2} = 1.05 * P_{\text{ind}}$,
- from the measured modulation values m_i at powers P_{W_i} ranging from $0.9 * P_{\text{fit},1}$ to $1.1 * P_{\text{fit},1}$, the accompanying value of $P_{\text{target},1}$ is determined,
- from the measured modulation values m_i at powers P_{W_i} ranging from $0.9 * P_{\text{fit},2}$ to $1.1 * P_{\text{fit},2}$, the accompanying value of $P_{\text{target},2}$ is determined,
- now P_{target} is calculated from the intersection of the line through the points $(P_{\text{target},1}, P_{\text{fit},1})$ and $(P_{\text{target},2}, P_{\text{fit},2})$ with the line represented by $P_{\text{target}} = P_{\text{fit}}$,
resulting in:
$$P_{\text{target}} = \frac{P_{\text{target},2} * P_{\text{fit},1} - P_{\text{target},1} * P_{\text{fit},2}}{P_{\text{target},2} - P_{\text{target},1} - P_{\text{fit},2} + P_{\text{fit},1}}$$
- the final accuracy, if needed, can be improved by a number of iterations.

Now P_{WO} and P_{EO} are obtained by:

$$P_{WO} = \rho * P_{\text{target}}$$

$$P_{EO} = \varepsilon * P_{WO}$$

with ρ and ε as given in Additional Information 1 (see chapter 4.4.4) and Additional Information 2 (see chapter 4.4.5)

remark 4:

The OPC procedure should be performed in an area on the CD-RW disc that is specially reserved for this purpose: the **Power Calibration Area** (PCA, see chapter 5.3).

remark 5:

Before using the PCA on a blank disc for an OPC procedure, it is strongly recommended that the tracks in the PCA are erased once by irradiating the tracks using only the P_E power ($P_E = \varepsilon * \rho * P_{\text{ind}}$)

Attachment 4 (normative)

13.4 Environment: operating and storage conditions

Operating Conditions:

Rapid changes in temperature and humidity within these ranges may cause too large a deflection. Recovery times up to several hours have to be taken into account before reading from or recording in discs.

Recommendation: No condensation may occur on the disc.

Storage Conditions:

For storage and transport of discs before and after recording the following climatic tests are used to simulate typical conditions:

Dry Heat Test according to IEC 68-2-2 Ba

Temperature : 55 °C
Relative Humidity : max. 50% at 35 °C
Storage Time : 96 hrs.

Cyclic Damp Heat Test according to IEC 68-2-30 Db

Temperature : 40 °C max.
Temperature : 25 °C min.
Cycles : 6
Relative Humidity : 95%
Cycle Time : 12 + 12 hrs.

After these tests one should allow for some recovery time before reading from or recording in tested discs.

Attachment 5 (normative)**13.5 Push Pull magnitude and the Normalized Push Pull Ratio**

The definition of the Push Pull Amplitude in the Orange Book is basically the same as in the Red Book chapter 15. and 15.1.

- For the recorded part of the CD-RW disc, the definition is exactly the same as in the Red Book, and so the normalization is to I_{top} : $|I_1 - I_2| / I_{top}$ at 0.1 μm offset = 0.08 - 0.12.
- For the unrecorded part of the CD-RW disc no I_{top} value is available. I_g is chosen for normalization, because this signal is available when tracking in the unrecorded groove:

$$|I_1 - I_2| / I_g \text{ at } 0.1 \mu\text{m offset} = \text{not specified.}$$

There is no range specified for Push Pull amplitude before recording, because a more important value is the ratio of the Push Pull signals before and after recording. This is because the servo electronics have to deal with both recorded and unrecorded parts of a partially recorded disc, and so with two different Push Pull signals. As the dynamic range of the servo electronics is limited, the allowed ratio in Push Pull signals should be specified. Therefore the Normalized Push Pull Ratio (NPPR) is defined as:

$$\frac{|I_1 - I_2| / I_g}{(|I_1 - I_2|)_a / I_{ga}} = 0.5 - 1.3$$

where: I_g = groove level before recording.

I_{ga} = averaged groove level after recording: the averaged ($\tau=15 \mu\text{s}$) HF signal before AC coupling.

This signal is chosen for normalization because it is actually used by the servo electronics for tracking in a recorded groove.

note: The specification for Push Pull magnitude after recording has been changed from 0.04-0.09 (Red Book) to 0.08-0.12 in order to facilitate design of pre-grooved CD-RW media.

Attachment 6 (informative)

13.6 Measurement of the groove wobble amplitude

The wobble amplitude in nm cannot easily be measured directly. However, it can be derived from the normalized wobble signal. The theoretical results for such a derivation are given below.

Relation between normalized wobble signal and wobble amplitude

According to specification point 1.4.4, the wobble signal I_W can be seen as:

$$I_W = A * \sin\left(\frac{2 * \pi * a}{p}\right) \quad (1)$$

where a = wobble amplitude in nm (typical 30nm)
 p = track pitch of the radial error signal
 A = the peak value of the radial error signal

In Figure 0-4 and Figure 0-5 the parameters a , p , A and I_W are shown. The averaged centre of the groove is taken as point 'o'. The groove has a peak displacement of 'a' (wobble amplitude) from the averaged centre of the groove to the actual centre of the groove. The normalized wobble signal can now be defined as:

$$\frac{I_{W-rms}}{(I_1 - I_2)_{pp}} = \frac{I_W}{2 * A * \sqrt{2}} = \frac{\sin(2 * \pi * a/p)}{2 * \sqrt{2}} \quad (2)$$

where

$$I_{W-rms} = I_W / \sqrt{2}$$

$$(I_1 - I_2)_{pp} = 2 * A$$

The definition in (2) is consistent with specification point 16.2. in chapter 2.2. The wobble signal (1) is not only dependent on the wobble amplitude 'a', but also the track pitch 'p'. Due to normalization, dependencies on groove geometry, spot shape and optical aberrations have been eliminated.

Tolerances of the normalized wobble signal

From the above formula for the normalized wobble signal, the tolerances as given in specification point 16.2 of chapter 2.2 can be converted to nm for a given track pitch of 'p' = 1.6 microns.

Lower limit: 0.035 corresponds to 25 nm.

Upper limit: 0.060 corresponds to 43 nm.

Measurement suggestions

The wobble signal and the push-pull signal should be filtered before measurement. The wobble signal should be filtered through a 10 - 30 kHz bandpass filter, the push-pull signal through a 5 kHz lowpass filter. The push-pull signal should be averaged such that the influences of incidental defects in the disc are minimised.

The wobble signal should be measured at a location where the wobbled groove is in phase with the neighbouring grooves. This corresponds to the positions with minimum wobble amplitude (this situation repeats with 1 ± 0.4 Hz at $N=1$). In this case no enhancement of the wobble signal occurs, due to positive interference. It is possible that no true minimum is

Measurement of the groove wobble amplitude

found due to low crosstalk levels between neighbouring grooves. One must average the wobble signal such that the influences of incidental defects in the disc are eliminated.

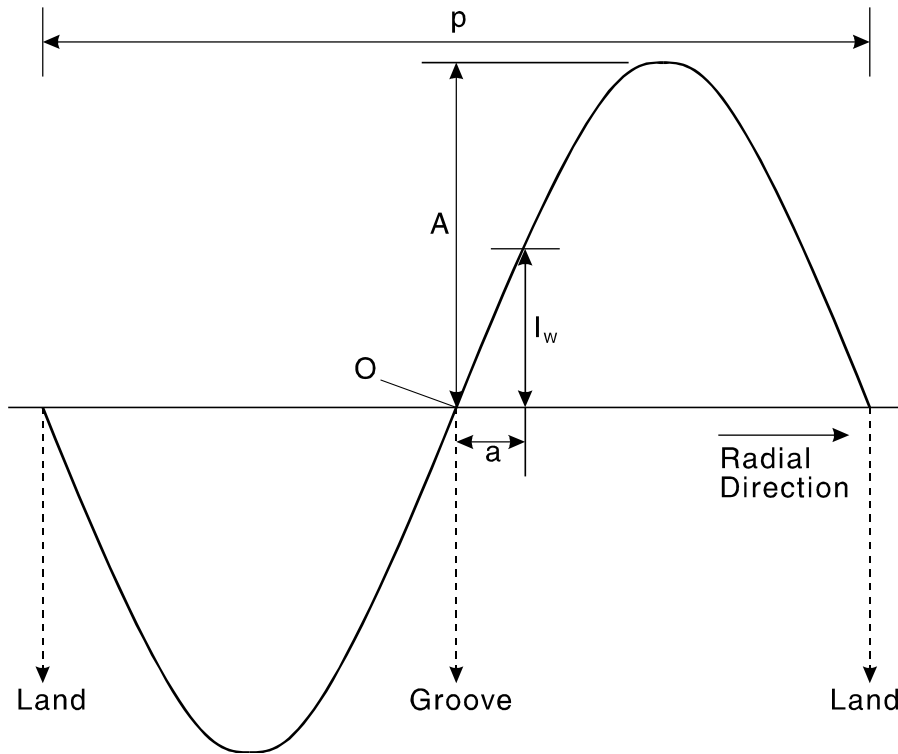

Figure 0-4 The radial error signal

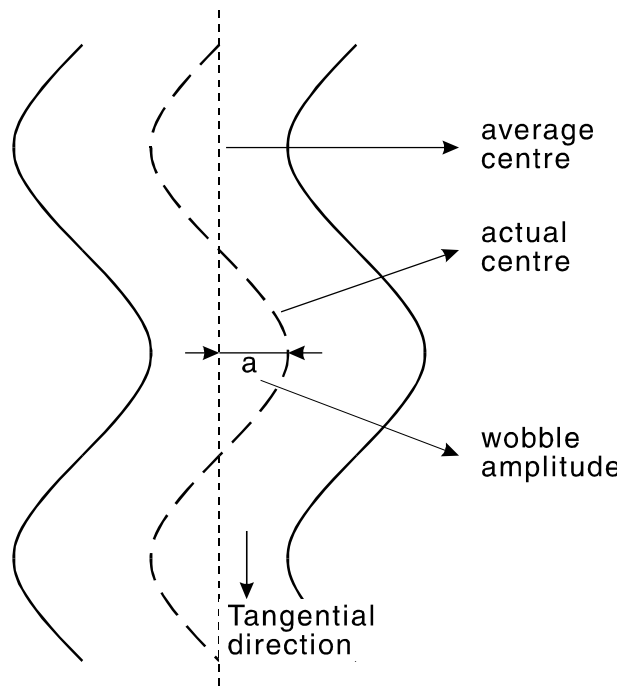

Figure 0-5 The groove wobble

Attachment 7 (normative)

13.7 The use of the Pre-Gap

In chapter 5.6.5.1 is described how the Pre Gap must be used in the CD-RW system. This attachment is a further clarification of that chapter.

In the Yellow Book the transitions of different kinds of Tracks are described. For some transitions, a Pre Gap is prescribed:

- from an Audio Track to a Data Track Mode 1 or 2.
- from a Data Track Mode 1 to a Data Track Mode 2.
- from a Data Track Mode 2 to a Data Track Mode 1.

In chapter 5.6.5.1 is described that in these cases, the Pre Gap must be according to these definitions in the Yellow Book or Green Book. An addition to this is, that the second part of the Pre Gap must include the Track Descriptor Block, instead of only zero data.

For some Track transitions, no Pre Gap is prescribed:

- from a Data Track Mode 1 to a Data Track Mode 1.
- from a Data Track Mode 2 to a Data Track Mode 2.

In chapter 5.6.5.1 is described that in these cases, the Pre Gap must be 150 blocks long. It consist of block encoded data including the Track Descriptor Block.

Figure 0-6 describes examples of the Track transitions. In this table, the contents of the subcode-Q channel TNO and INDEX are given for both the first and the second part of the Pre Gap (referred to as 1 and 2), as well as the Track Mode, Track Mode / Form, length of each part and the contents of the main channel data.

Some explanations to Figure 0-6:

- TDB = Track Descriptor Block
- x = Track number of the "next" Track (in fact the Track number that is used in the data following the Pre Gap).
- Length in blocks = The indicated length includes the Link-, Run-in and Run-out blocks that might be present in the Pre Gap (see also chapter 5.6.5.1).
- = not applicable
- Form = If Mode 2 is used according to the CD-ROM-XA specification, Form 1 or Form 2 must be used. If CD-ROM Mode 2 is used Form 1 or Form 2 is not applicable.

Track Transition	Subcode TNO		Subcode INDEX		Track Mode		Track Form		Length in Blocks		Main Channel Contents	
	1	2	1	2	1	2	1	2	1	2	1	2
Audio to Mode 1	x	x	0	0	-	1	-	-	≥75	≥150	Dig. silence	Block encoded, including TDB
Audio to Mode 2	x	x	0	0	-	2	-	1 or 2	≥75	≥150	Dig. silence	Block encoded, including TDB
Mode 1 to Mode 2	x	x	0	0	1	2	-	1 or 2	≥75	≥150	Block encoded, all zero data	Block encoded, including TDB
Mode 2 to Mode 1	x	x	0	0	2	1	1 or 2	-	≥75	≥150	Block encoded, all zero data	Block encoded, including TDB
Mode 1 to Mode 1	-	x	-	0	-	1	-	-	-	150		Block encoded, including TDB
Mode 2 to Mode 2	-	x	-	0	-	2	-	1 or 2	-	150		Block encoded, including TDB
Mode 1 or 2 to Audio	-	-	-	-	-	-	-	-	-	-	No Pre-gap, start Track with ≥ 2 seconds digital silence	
Lead-in to Mode 1	-	x	-	0	-	1	-	-	-	150		Block encoded, including TDB
Lead-in to Mode 2	-	x	-	0	-	2	-	1 or 2	-	150		Block encoded, including TDB, Subheaders 00

Figure 0-6 Contents of the first and second part of the Pre Gap (1 and 2 in the table)

Attachment 8 (normative)

13.8 The use of addressing Method 1 and Method 2

The Addressing Method gives the relation between the Logical Block Number (LBN) and the Block Address in the Block Header. There are two methods:

Method 1:

$$\text{LBN} = (((\text{MIN} * 60) + \text{SEC}) * 75 + \text{FRAMES}) - 150$$

Method 2:

The LBN's upto and including the first User Data Block in a Track are calculated by:

$$\text{LBN} = (((\text{MIN} * 60) + \text{SEC}) * 75 + \text{FRAMES}) - 150$$

All the following LBN's are calculated by counting all User Data Blocks in the Track. This means that all Run-in blocks, Run-out blocks and Link blocks are excluded.

Basically, Method 1 is used on the entire disc. Only *within* an incrementally written Track with fixed Packets, Method 2 shall be used. For an incrementally written Track with variable length Packets, only addressing method 1 can be used.

For the entire disc, the first block of each Track has an address according to Method 1. This means that between the end of an incrementally written Track with fixed Packets and the next Track, there will be a discontinuity in the addressing of the Logical sectors. This is shown in Figure 0-7: Example of addressing Method 1 and 2.

A further explanation of Figure 0-7:

Track number 1 is written uninterrupted, and so addressing Method 1 is used. Track 2 is written incrementally with fixed Packet size, and so within the Track (after the first User Data Block) addressing Method 2 is used. As the Pre Gap of Track 2 is written separately, there is a link point at the end of this Pre Gap. The Link block and 4 Run-in blocks that precede the first blocks with user data, are included in the Pre Gap. The last LBN of Track 2 is (according to Method 2) 9383. The first LBN of Track 3 is (according to Method 1) 9550. So there is a discontinuity in the block numbering between Track 2 and 3.

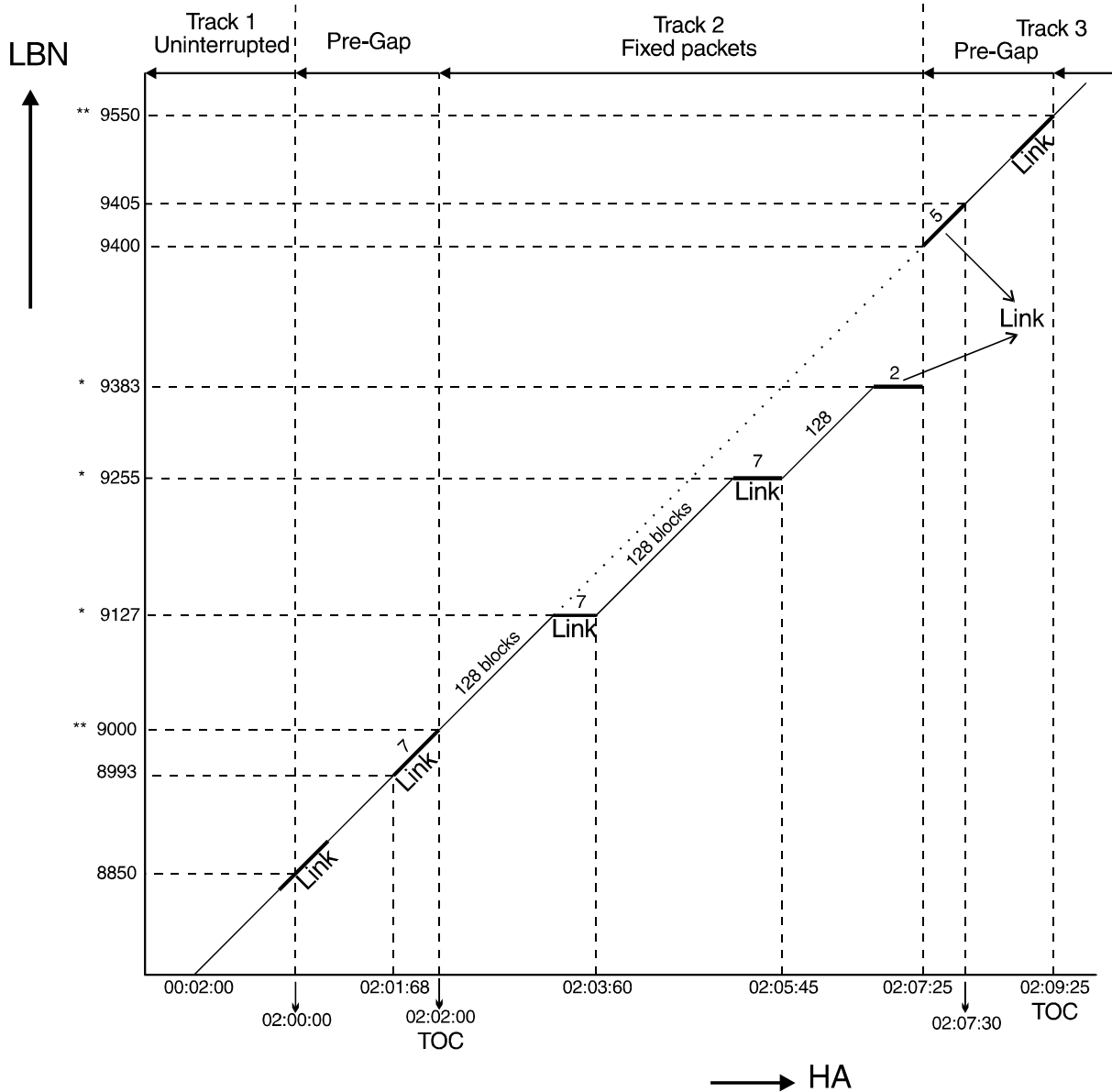

Figure 0-7 Example of addressing Method 1 and 2

- Drawing not to scale
- * = Last user data block
- ** = First user data block
- HA = Header address
- LBN = Logical Block Number
- Link = $2 * RO + LB + 4 * RI$
- RO = Run-out block
- LB = Link block
- RI = Run-in block
- TOC = Address in the TOC

Attachment 9 (normative)

13.9 Serial Copy Management System (SCMS)

13.9.1 Scope

13.9.1.1 General

The CD-RW system adopts SCMS for consumer audio use.

The technical requirements, the recording rules and the playback rules which are required for the implementation of SCMS are given in the next chapters. All CD-RW equipment for consumer audio use must fulfil these requirements and act properly according to these rules.

13.9.1.2 SCMS implementation

The implementation of SCMS in the CD-RW system is based on:

- 1: Correct reading and interpretation of the recorder input signal, with regards to Copyright Status, Generation Status and Category Code.
- 2: Correct recording of the "Copy bit" in the CD-RW disc, according to the Recording rules given in chapter 13.9.5.
- 3: Correct reading of the "Copy bit" from the disc, and giving the correct output to the Digital Output Interface according to the Playback rules given in chapter 13.9.4.

13.9.2 Normative references

IEC 60958³: Digital Audio Interface, part 1 (General), part 3 (Consumer applications) and part 4 (Professional applications).

13.9.3 Technical requirements for CD-RW equipment

All CD-RW equipment for consumer audio use shall keep to the CD-RW Playback Rules and CD-RW Recording Rules as specified below. Category codes and copyright status bit included in the digital input signals shall not be deleted or modified and shall be monitored continuously and acted upon accordingly.

³ To be published in 1998; at present see: IEC 100C/193/CDV (part 1)
IEC 100C/194/CDV (part 3)
IEC 100C/195/CDV (part 4)

13.9.4 CD-RW playback rules

The digital output shall be in accordance with IEC 958.

An overview of the CD-RW Playback Rules is given in Figure 0-8.

Note: Alternative digital output may be used only in closed systems (e.g. double CD-RW deck, CD/CD-RW combinations or integrated stereo systems). The digital output of these systems shall provide for equivalent coding, specifically with respect to category code, copyright status and generation status, such that it is functionally compatible with SCMS.

13.9.4.1 Channel Status

13.9.4.1.1 Category code

CD-RW equipment shall provide the category code 10000000 in the channel status bits of the digital output signal.

13.9.4.1.2 Copyright status bit

CD-RW equipment shall provide the copyright status bit (bit 2 or "C-bit") in the channel status bits of the digital output signal. The copyright status shall be applied in the digital output signal as follows, in accordance with the status of the disc replayed. This copyright status on the disc is given by bit 1 of CONTROL in the subcode Q channel as described in chapter 5.6.3 of this document (further on referred to as "Q-CONTROL bit 1").

- If "Q-CONTROL bit 1" is "0", the "C-bit" shall be set for "copyright protected: "C" is "0".
- If "Q-CONTROL bit 1" is "1", the "C-bit" shall be set for "not copyright protected: "C" is "1".
- If "Q-CONTROL bit 1" is alternating between "1" and "0" (referred to as "alt"), the "C-bit" shall be set for "home copy of copyright protected original": "C" = "alt".

13.9.4.1.3 Consumer/Audio bits

CD-RW equipment for consumer audio use shall apply according to IEC 958 the following in the channel status bits of the digital output :

- bit 0 is "0" (consumer use)
- bit 1 is "0" (audio)

Figure 0-8 CD-RW playback rules: Channel Status

Playback disc	Flags coming from disc: Q-CONTROL bit 1	Channel Status at digital output			maximum possible copies
		"C-bit" = bit 2	Category code	L-bit = bit 15	
CD, CD-R or CD-RW	1	1	1000000	0	infinite
	0	0	1000000	0	1
	alt	alt	1000000	0	0

13.9.4.2 User data

Subcode Q-channel data from the disc shall be assigned to the User Data channel of the digital output according to IEC 958.

CD-RW System Description

13.9.5 CD-RW recording rules

An overview of the Recording Rules are given in Figure 0-9 "Recording rules" and Figure 0-10 "SCMS logic diagram".

The next chapters 13.9.5.1 to 13.9.5.10 are additions to or clarifications of the Figure 0-9 and Figure 0-10.

13.9.5.1 The Serial Copy Management System (SCMS) applies to consumer audio CD-RW equipment. Recording of digital non-consumer signals is inhibited. With channel status "bit 0" is "1" (professional source) recording is inhibited.

13.9.5.2 Recording of digital non-audio signals is inhibited. When channel status "bit 1" is "1", recording is inhibited.

13..9.5.3 In the case of a source which is without category information, e.g. without channel status bits or with an undefined category code, independent of the status of the copyright bit or the L-bit of the category code, the status "home copy of copyright protected original" shall be recorded on disc (Q-CONTROL bit 1= "alt").

13..9.5.4 Recording shall not be possible for digital input signals with a copyright status bit C-bit="alt" (alternating with a frequency from 4 to 10 Hz between "copyright protected" (C-bit="0") and "not copyright protected" (C-bit="1")) when the category code is from a compact disc digital audio signal (10000000).

13..9.5.5 For digital input signals originating from an analogue-digital converter, whether or not included as part of a CD-RW equipment, with category code "01100XXL" or originating from other sources with category code "general", "00000000", the status "copyright protected" (Q-CONTROL bit 1 = "0" shall be recorded on disc, independent of the status of the copyright status bit or category code L bit of the input signal. This requirement shall not be applied to the analogue-digital converter of the type specified in chapter 13.9.5.9.

NOTE: The digital input signal referred to in this chapter does not contain correct source information of the original signal before digitization. The analogue-digital converter is of the type which does not supply (correct) source information.

13.9.5.6 For digital input signals with a copyright status bit set for "not copyright protected" (C-bit="1"), the status "not copyright protected" shall be recorded on disc (Q-CONTROL bit 1= "1"), except for cases specified in chapters 13.9.5.3 and 13.9.5.5.

13.9.5.7 Recording shall be possible for digital input signals listed in Figure 0-9 with a copyright status bit set for "copyright protected" (C-bit="0") and the L-bit set for "Pre-rec". The status "home copy of copyright protected original" shall be recorded on disc (Q-CONTROL bit 1 ="alt").

13.9.5.8 Recording shall be inhibited for digital input signals with a copyright status bit set for "copyright protected" (C-bit="0"), except for the cases specified in chapters 13.9.5.3, 13.9.5.5 and 13.9.5.7.

13.9.5.9 For digital input signals originating from an analogue-digital converter with category code "01101XXL", which can deliver original source information on copyright status from the analogue domain, the requirement stated in chapter 13.9.5.5. shall not be applied.

13.9.5.10 For analog inputs, the status "copyright protected" shall be recorded on disc (Q-CONTROL bit 1 ="0").

CD-RW System Description

Figure 0-9 CD-RW Recording Rules for all allowed input signals

Input source	Channel status of digital input signal C-channel acc.to IEC 60958			Recorded on CD-RW disc	Maximum remaining serial copies
	Copy bit "C-bit"=bit 2	Cat.code bit 8..14	L bit bit 15		
	Not copyright protected			Q-CONTROL bit 1	
D/D converter	1	010xxx	x	1	infinite
Magnetic prod.	1	110xxx	x	1	
Music.instr.	1	101xxx	x	1	
Fut.A/D conv	1	01101xx	x	1	
Sol.state rec.	1	0001xxx	x	1	
Experimental	1	0000001	x	1	
Laser-opt.prod.	1	100xxx	x	1	
Broadcast recept.	1	001xxx	x	1	
Broadcast recept.	1	0111xxx	x	1	
	Copyright protected		Home copy		
D/D converter	0	010xxx	0	not recordable	0
Magnetic prod.	0	110xxx	0		
Music.instr.	0	101xxx	0		
Fut.A/D conv	0	01101xx	0		
Sol.state rec.	0	0001xxx	0		
Experimental	0	0000001	0		
Laser opt.prod.	alt	100xxx	x		
Laser opt.prod.	0	100xxx	1		
Broadcast recept.	0	001xxx	1		
Broadcast recept	0	0111xxx	1		
	Copyright protected		Pre-rec		
D/D converter	0	010xxx	1	alt	0
Magnetic prod.	0	110xxx	1	alt	
Music.instr.	0	101xxx	1	alt	
Fut.A/D conv	0	01101xx	1	alt	
Sol.state rec.	0	0001xxx	1	alt	
Experimental	0	0000001	1	alt	
Laser opt.prod.	0	100xxx	0	alt	
Broadcast recept.	0	001xxx	0	alt	
Broadcast recept.	0	0111xxx	0	alt	
General	x	0000000	x	0	1
Actual A/D	x	01100xx	x	0	1
no category code	x	-	x	alt	0
Analog signal	-	-	-	0	1

x = either "0" or "1"
alt = alternating between "1" and "0"
- = not applicable

CD-RW System Description

Figure 0-10 SCMS logic diagram

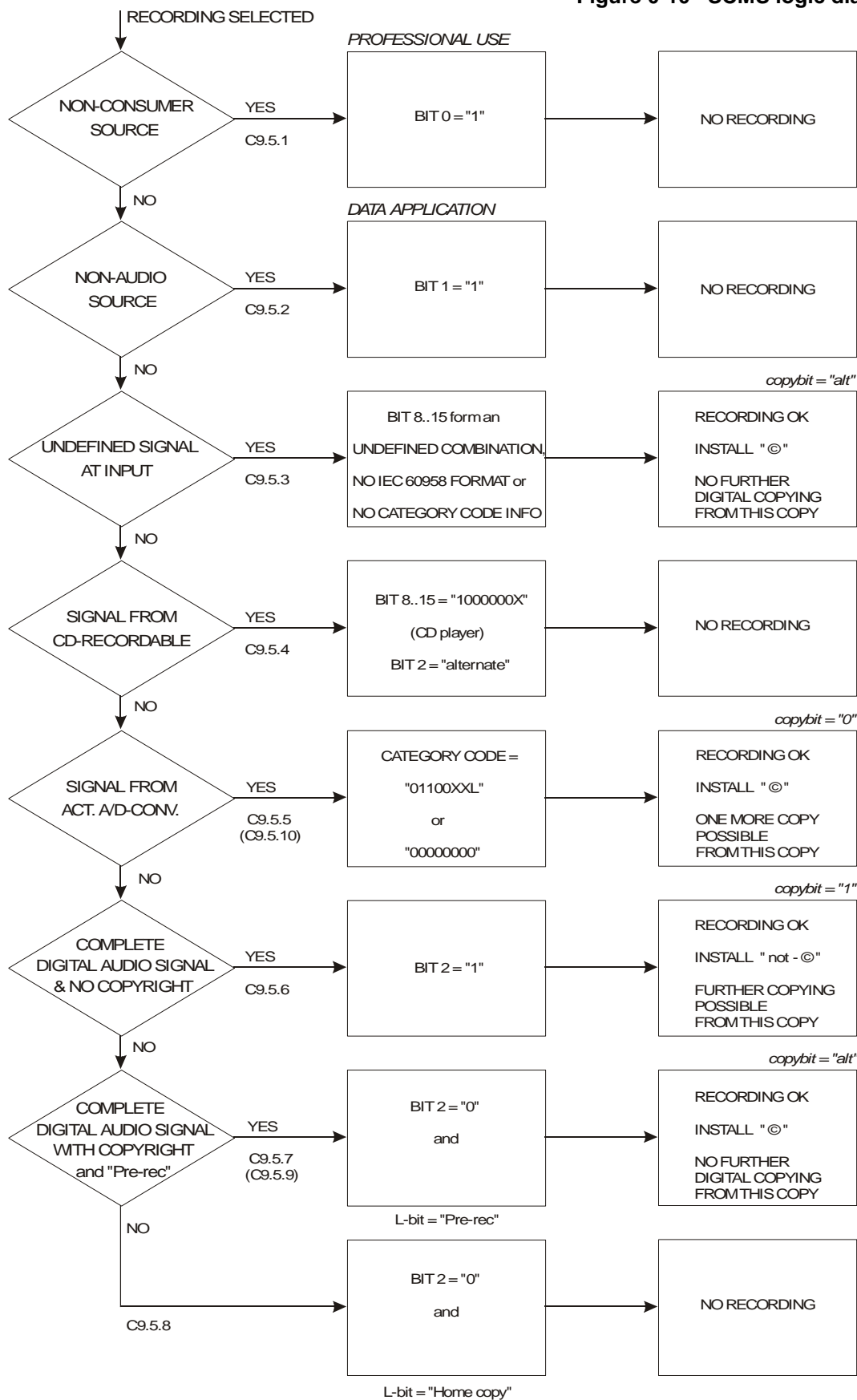

Attachment 10 (informative)**13.10 Write-strategy optimization**

Write performance is highly depending on several aspects. Important parameters that influences write performance are:

- Spot orientation
- Write-strategy
- Disc technology

In the next paragraphs some guidelines are described to optimize write performance due to these parameters.

13.10.1 Spot orientation

The Highest Test Speed, as indicted by Additional Info 1 (1T) and Additional Info 2 (2T) is determined by applying spot characteristics described in paragraph 2.1.2 'recorder optical pickup'.

Drives that have a optical spot characteristic that do not fulfill this specification may be restricted in maximum writing speed due to specific characteristics of US CD-RW discs.

13.10.2 Write-strategy

All media according the US CD-RW shall at least fulfill the US CD-RW test conditions described in Chapter 2.1.3. Since many different disc manufacturers will manufacture US CD-RW discs, disc technology will vary. By fine tuning Write-strategy to these specific differences in disc technology, write performance can be improved furthermore therefore.

For this purpose recognition of the disc manufacturer is needed. This can be implemented by using the MID code of each disc manufacturer, see Chapter 4.4.6.2.

Disc manufacturers who fulfill the US CD-RW specification by having their media certified by the Philips IP&S support laboratory may be published on the manufacturers list, published in the licensing website of Philips IP&S.

A lookup table in the drive can be applied to correlate specific optimum Write-strategy settings with known disc manufacturers identified by their MID codes.

To be able to handle also unknown media it is strongly advised to include a default Write-strategy⁴ for discs with unknown MID codes.

When a disc with unknown MID code, unknown HTS bit settings or unknown disc sub-type is detected it is recommended to handle that disc for writing according the flowchart in Figure 0-11.

⁴ A default Write-strategy that is developed by the drive manufacturer for a particular drive model. A default Write-strategy may apply at lower speeds than specified by HTS.

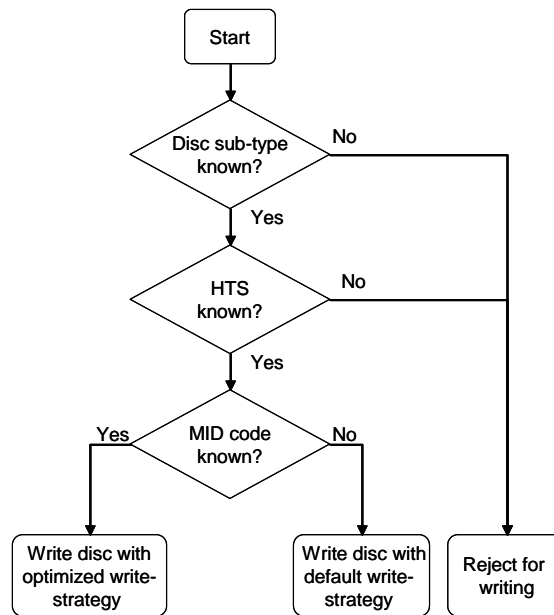

Figure 0-11: Recommended drive action with respect to unknown media

13.10.3 Writing with '1T' strategy at lower speeds than 1T Lowest Test Speed

Writing with a '1T' Write-strategy at 16x nominal CD speed is a mandatory test condition for US24 media. Writing at lower speeds than 16x down to 8x with '1T' Write-strategy is advised to be implemented as follows:

Fixed length of T_{mp} , equal to the length at 16x, described in chapter 2.1.3.2.1, at all speeds between 8x and 16x ($T_{mp} = 3.6 \text{ ns}$).

Fixed length of T_{top} , equal to the length at 16x described in chapter 2.1.3.2.1, at all speeds between 8x and 16x ($T_{top} = T_{mp} + dT_{top} = 3.6 \text{ ns} + m \cdot 0.9 \text{ ns}$ or $2.7 \text{ ns} + m \cdot 0.9 \text{ ns}$).

This page is intentionally left blank

