

# Standard ECMA-401

2<sup>nd</sup> Edition / December 2021

## Close Capacitive Coupling Communication Physical Layer (CCCC PHY)

# Standard



**COPYRIGHT PROTECTED DOCUMENT**

<b>Contents</b>	<b>Page</b>
1 Scope .....	1
2 Normative references .....	1
3 Terms, definitions and abbreviated terms .....	1
3.1 Terms and definitions .....	1
3.2 Abbreviated terms .....	1
4 Conventions and notations .....	2
5 Conformance .....	2
6 Architecture .....	2
7 Reference plate-electrode assembly .....	5
8 PHY parameters .....	6
8.1 Voltage conditions .....	6
8.2 Bit representation .....	6
8.2.1 Bit duration .....	6
8.2.2 Bit encoding .....	7
8.3 Transmission .....	7
8.4 DC balance of a P-PDU .....	8
8.5 Reception of a P-PDU .....	8
9 P-PDU .....	8
9.1 Structure .....	8
9.2 Space .....	8
9.3 Level adjust .....	9
9.4 Pre-amble and Sync .....	9
9.5 Attribute .....	9
9.6 TDS number .....	10
9.7 Sequence number .....	10
9.7.1 Initial and range .....	10
9.7.2 Acknowledgement .....	10
9.8 Payload .....	10
9.9 CRC .....	10
9.10 Post-amble .....	10
9.11 Null P-PDU .....	10
9.12 Data P-PDU .....	10
10 PHY data unit (P-DU) .....	11
11 Segmentation and reassembly .....	11
12 TDS .....	11
13 LBT and synchronisation .....	12
13.1 LBT .....	12
13.2 Synchronisation .....	12
14 Association procedure .....	13
15 Communication .....	15
15.1 General .....	15
15.2 Full duplex communication .....	15
15.3 Broadcast communication .....	17
<b>Annex A (normative) Tests .....</b>	<b>19</b>

A.1	Reference plate-electrode test .....	19
A.2	P-PDU DC balance test.....	20
A.3	Protocol test .....	20
A.3.1	Test setup .....	20
A.3.2	Test scenario 1.....	21
A.3.3	Test scenario 2.....	21
A.3.4	Test scenario 3.....	22
A.3.5	Test scenario 4.....	22
A.3.6	Test scenario 5.....	22
A.3.7	Test scenario 6.....	22
A.3.8	Test scenario 7.....	22
A.3.9	Test scenario 8.....	22
<b>Annex B (informative)</b>	<b>Guidance for implementation of this document .....</b>	<b>57</b>
<b>Bibliography .....</b>		<b>59</b>

## Introduction

This Standard specifies the PHY protocol and for wireless communication between the Close Capacitive Coupling Communication (CCCC) devices.

This 2<sup>nd</sup> edition is aligned with ISO/IEC 17982:2021.

This Ecma Standard was developed by Technical Committee 51 and was adopted by the General Assembly of December 2021.

**"COPYRIGHT NOTICE**

© 2021 Ecma International

*This document may be copied, published and distributed to others, and certain derivative works of it may be prepared, copied, published, and distributed, in whole or in part, provided that the above copyright notice and this Copyright License and Disclaimer are included on all such copies and derivative works. The only derivative works that are permissible under this Copyright License and Disclaimer are:*

- (i) works which incorporate all or portion of this document for the purpose of providing commentary or explanation (such as an annotated version of the document),*
- (ii) works which incorporate all or portion of this document for the purpose of incorporating features that provide accessibility,*
- (iii) translations of this document into languages other than English and into different formats and*
- (iv) works by making use of this specification in standard conformant products by implementing (e.g. by copy and paste wholly or partly) the functionality therein.*

*However, the content of this document itself may not be modified in any way, including by removing the copyright notice or references to Ecma International, except as required to translate it into languages other than English or into a different format.*

*The official version of an Ecma International document is the English language version on the Ecma International website. In the event of discrepancies between a translated version and the official version, the official version shall govern.*

*The limited permissions granted above are perpetual and will not be revoked by Ecma International or its successors or assigns.*

*This document and the information contained herein is provided on an "AS IS" basis and ECMA INTERNATIONAL DISCLAIMS ALL WARRANTIES, EXPRESS OR IMPLIED, INCLUDING BUT NOT LIMITED TO ANY WARRANTY THAT THE USE OF THE INFORMATION HEREIN WILL NOT INFRINGE ANY OWNERSHIP RIGHTS OR ANY IMPLIED WARRANTIES OF MERCHANTABILITY OR FITNESS FOR A PARTICULAR PURPOSE."*

# Close Capacitive Coupling Communication Physical Layer (CCCC PHY)

## 1 Scope

This document specifies the close capacitive coupling communication physical layer (CCCC PHY) for full duplex and broadcast communication in time slots on frequency division multiplex channels.

NOTE An implementation for small size and low power devices is provided in Annex B.

## 2 Normative references

The following documents are referred to in the text in such a way that some or all of their content constitutes requirements of this document. For dated references, only the edition cited applies. For undated references, the latest edition of the referenced document (including any amendments) applies.

ISO/IEC 7498-1, *Information technology — Open Systems Interconnection — Basic Reference Model: The Basic Model*

ITU-T Rec. V.41, *Data communication over the telephone network — Code-independent error-control system*

## 3 Terms, definitions and abbreviated terms

### 3.1 Terms and definitions

For the purposes of this document, the terms and definitions given in ISO/IEC 7498-1 and the following apply.

ISO and IEC maintain terminological databases for use in standardization at the following addresses:

- ISO Online browsing platform: available at <https://www.iso.org/obp>
- IEC Electropedia: available at <http://www.electropedia.org/>

#### 3.1.1

##### **listener**

entity that does not initiate communication

#### 3.1.2

##### **talker**

entity that initiates communication

### 3.2 Abbreviated terms

CRC	cyclic redundancy check
CCCC	close capacitive coupling communication
DUT	device under test

FDC	frequency division channel
LBT	listen before talk
LEN	length
P-DU	PHY data unit
P-PDU	PHY PDU
PHY	physical layer
RFU	reserved for future use
TDS	time division slot

## 4 Conventions and notations

The following conventions and notations apply in this document.

- A sequence of characters of 'A', 'B', 'C', 'D', 'E' or 'F' and decimal digits in parentheses represent numbers in hexadecimal notation unless followed by a 'b' character.
- Numbers in binary notation and bit patterns are represented by a sequence of 0 and 1 digits or 'X' characters in parentheses followed by a 'b' character, e.g. (0X11X010)b. Where X indicates that the setting of a bit is not specified, and the leftmost bit is the most significant bit unless the sequence is a bit pattern.

## 5 Conformance

Conforming entities implement:

- both talker and listener;
- listen before talk (LBT) for both talker and listener;
- the capability to execute association on FDC2 and to communicate on (FDC0 and FDC1), (FDC3 and FDC4), or (FDC0, FDC1, FDC3 and FDC4);
- the capability for talkers and listeners to use any of the 8 TDS on an FDC;
- both full duplex and broadcast communication, and pass the tests specified in Annex A.

## 6 Architecture

The protocol architecture of CCCC follows ISO/IEC 7498-1 as the basic model. CCCC devices communicate through mediators, such as conductive and dielectric materials.

Plate-electrodes for CCCC device E and F are equivalent to the reference plate-electrode assembly.

The plate-electrode A faces to the imaginary point at infinity and the plate-electrode B faces to the mediator. The plate-electrode C faces to the mediator and the plate-electrode D faces to the imaginary point at infinity. See Figure 1.



Figure 2 is the equivalent circuit of Figure 1. The voltage of X is the potential of the point at infinity. The voltage of Y is the potential of the point at infinity. It is deemed that the potential of X and Y is identical. Therefore, X and Y is imaginary short. Consequently, devices E and F are able to send and receive signal.

Regarding the information transfers from CCCC devices E to F, device E changes the voltage between plate-electrode A and B. It changes the electric charge between plate-electrode B and the mediator. The change in electric charge affects device F by the capacitive coupling between plate-electrode C and mediator. Plate-electrodes A and B and plate-electrodes C and D have potential differences of reverse polarity; therefore, device F senses the information as changes in voltage between plate-electrode C and D.

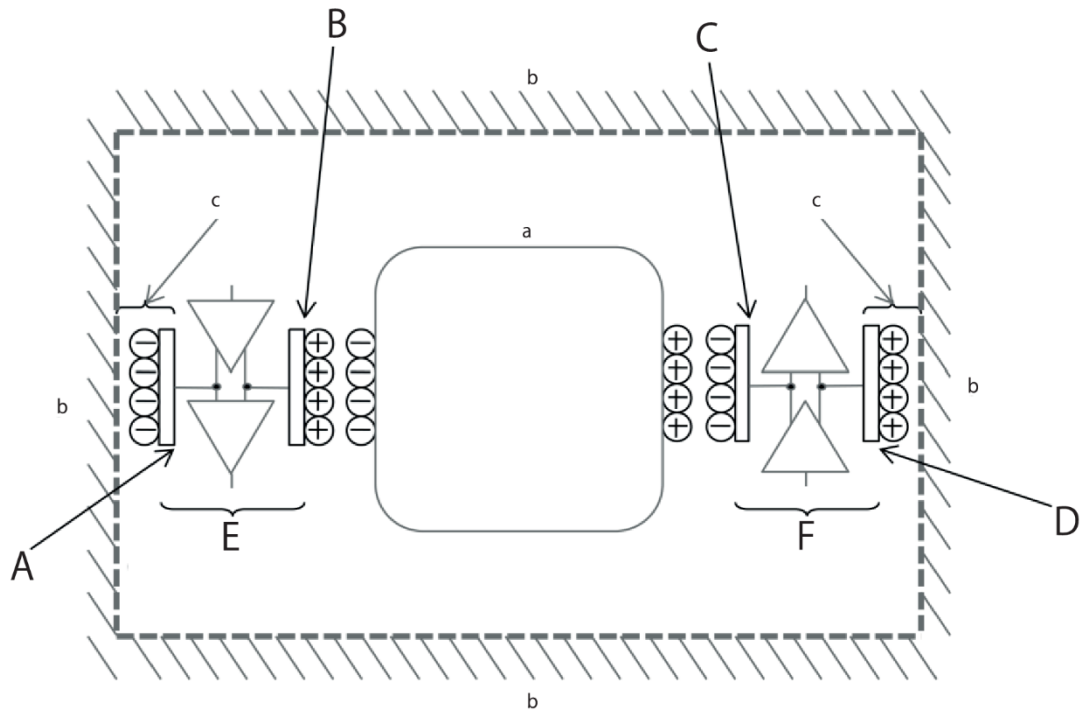

**Key**

**Components**

- A plate-electrode A
- B plate-electrode B
- C plate-electrode C
- D plate-electrode D
- E CCCC device E
- F CCCC device F
- a Mediator, conductive materials or dielectric materials.
- b Point at infinity.
- c Electrostatic capacity.

**Figure 1 — Electrical models**

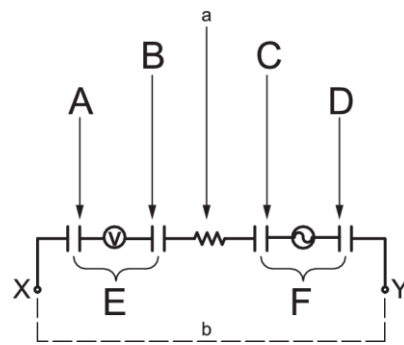

a) Device E is listening and device F is talking

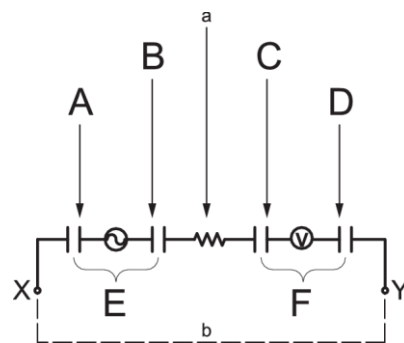

b) Device E is talking and device F is listening

#### Key

#### Components

- A plate-electrode A
- B plate-electrode B
- C plate-electrode C
- D plate-electrode D
- E Closed Capacitive Coupling Communication device E
- F Closed Capacitive Coupling Communication device F
- a Conductive materials or dielectric materials.
- b Imaginary short.

**Figure 2 — Equivalent circuit**

Information transfer between CCCC devices E and F takes place by synchronous communication, see subclause 13.1. Subclause 8.2.1 specifies five frequency division channels (FDC) by division of the centre frequency. Each FDC consists of a sequence of time-segments. Each time-segment consists of eight time division slots (TDS) for time division multiple-access, see Clause 12. Peers use the listen before talk (LBT) procedure in subclause 13.1 to ascertain that a TDS is not occupied. The TDSs are negotiated using the association procedure specified in Clause 14.

Subclauses 15.1 and 15.2 specify full duplex and broadcast communication respectively. In full duplex communication, talkers and listeners exchange P-PDUs (see Clause 9) by synchronous communication. In broadcast communication, talkers broadcast P-PDUs and listeners receive P-PDUs without acknowledgment.

Length information and CRC is added to the SDU to construct a PHY data unit (P-DU), see Clause 10. The sender segments the P-DU into P-PDUs. The receiving entity reassembles the P-PDUs into the P-DU, see Clause 11, and forwards the SDU to its PHY user as illustrated in Figure 3.

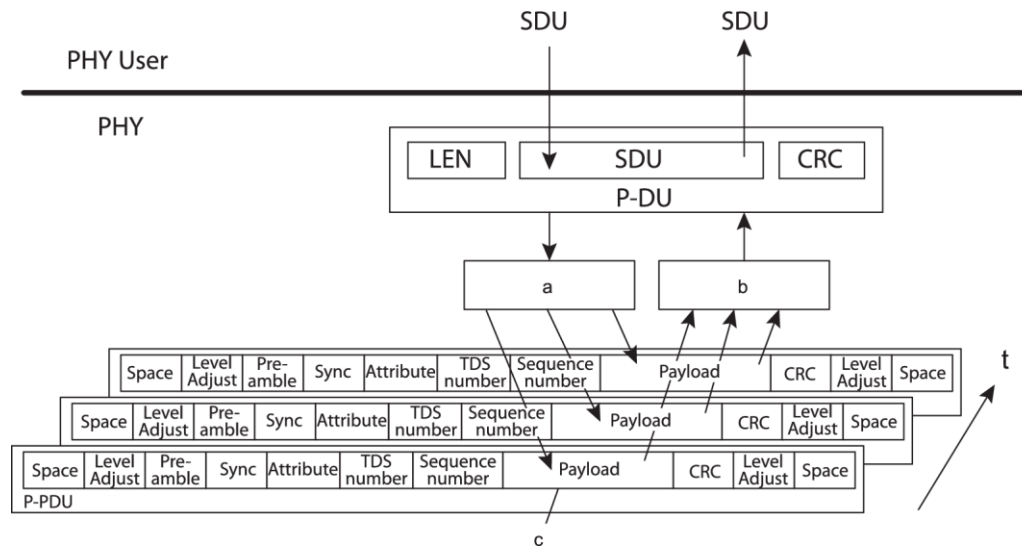

### Key

- a Segmentation.
- b Reassembly.
- c Segmented P-PDU.
- t time

Figure 3 — PHY model

## 7 Reference plate-electrode assembly

The reference plate-electrode assembly for the CCCC devices shall consist of plate-electrode A and plate-electrode B as specified in Figure 4. Dimensional characteristics are specified for those parameters deemed to be mandatory.

$$a = 20,0 \pm 0,1 \text{ mm}$$

$$b = 20,0 \pm 0,1 \text{ mm}$$

The distance *c* between plate-electrode A and B shall be  $5,0 \pm 0,1 \text{ mm}$  by horizontal flat surface.

$$d = 0,30 \pm 0,03 \text{ mm}$$

The displacement of centre of area *e* between plate-electrode A and B shall be a maximum of 0,1 mm.

The material of the plate-electrodes shall be 99 % to 100 % copper or equivalent.

The twisted-pair wire shall be connected inside the circle area *f* specified in Figure 4. The circle area *f* has a diameter of  $2,0 \pm 0,5 \text{ mm}$ . The twisted-pair wire shall be stranded wire and 26, 27, or 28 specified American Wire Gauge. The length of the twisted-pair wire for the reference plate-electrode assembly shall be less than 1,0 m.

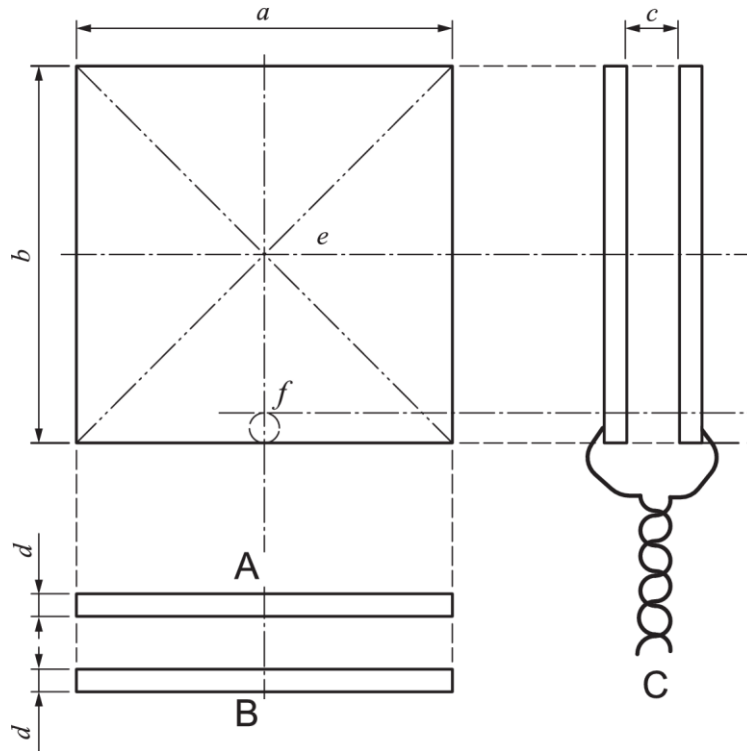

**Key**

**Components**

- A plate-electrode A
- B plate-electrode B
- C twist-pair wire

**Figure 4 — CCCC reference plate-electrode assembly**

**8 PHY parameters**

**8.1 Voltage conditions**

The following conditions of the voltage between the outer and the inner plate-electrode shall be used for communication:

- $+m$  Volts;
- $-m$  Volts;
- 0 Volt;
- OPEN.

The value  $m$  depends on implementations. 0 Volt is achieved by shorting the two plate-electrodes in a plate-electrode assembly. OPEN is achieved by disconnection of the plate-electrode assembly from the driver circuits.

**8.2 Bit representation**

**8.2.1 Bit duration**

The centre frequency  $f_c$  is  $40,68 \text{ MHz} \pm 50 \text{ Hz/MHz}$ .

The bit duration  $T$  equals  $D/f_c$  seconds.

Table 1 specifies the relation between FDC and  $D$ .

**Table 1 — FDC and  $D$**

FDC	$D$
0	11
1	7
2	5
3	3
4	1

### 8.2.2 Bit encoding

Manchester bit encoding is specified in Figure 5. Depending on the relative orientation, bits are received with either positive or negative polarity. The half bit time transition shall be between  $0,4 T$  and  $0,6 T$ .

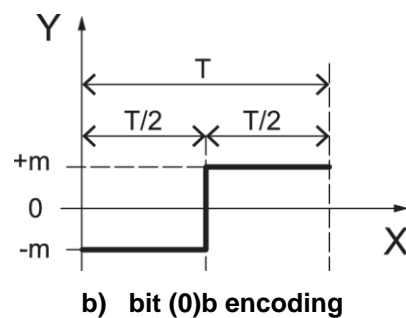
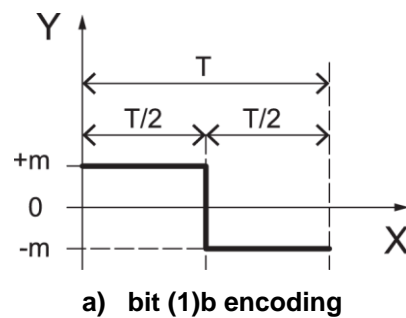

#### Key

X time

T bit time

**Figure 5 — Bit encoding**

### 8.3 Transmission

P-PDUs shall be transmitted byte-wise in the sequence specified in subclause 9.1. Bytes shall be transmitted with the least significant bit first.

## 8.4 DC balance of a P-PDU

The DC balance of a P-PDU is  $(S_p - S_n) / (S_p + S_n) \times 100$  [%] where  $S_p$  is the integral of the positive voltage parts of one P-PDU and where  $S_n$  is the integral of the negative voltage parts of one P-PDU. The DC balance shall be less than  $\pm 10$  % per P-PDU.

## 8.5 Reception of a P-PDU

While receiving a P-PDU, receivers shall put the voltage condition to OPEN.

# 9 P-PDU

## 9.1 Structure

Figure 6 specifies the P-PDU as a sequence of 0,5 T of space, 1,5 T of level adjust, 2 T of pre-amble, 5 T of sync, 2 T of attribute, 3 T of TDS number, 2 T of sequence number, 32 T of payload, 16 T of CRC, and 2 T of post-amble. The P-PDU continues/ends with 1,5T of level adjust and another 0,5T space. The bit encoding specified in 8.2.2 shall be applied to attribute, TDS number, sequence number, payload, and CRC.

66 T is represented by  $t_1, t_2, t_3, \dots, t_{66}$ .

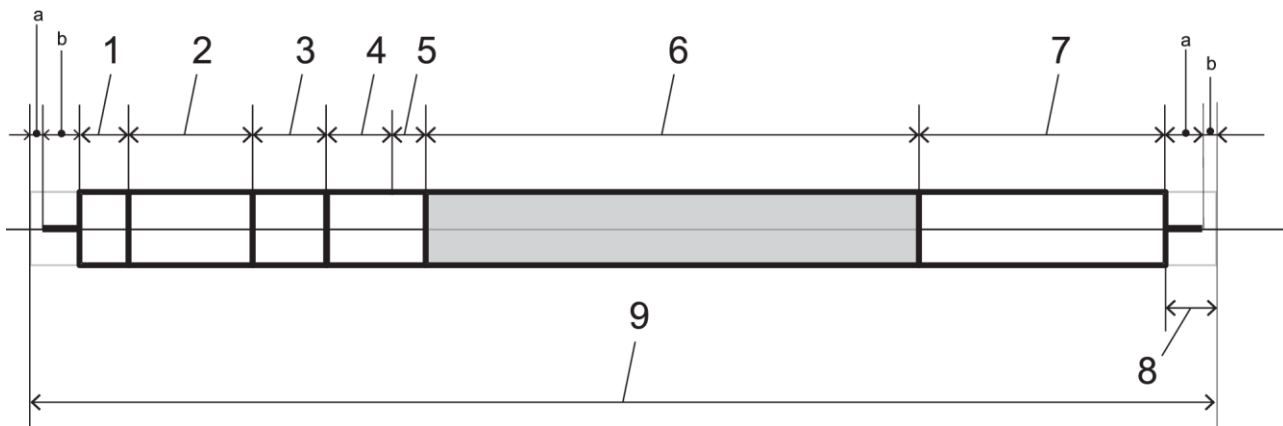

### Key

- 1 pre-amble (2 T)
- 2 sync (5 T)
- 3 attribute (2 T)
- 4 TDS number (3 T)
- 5 sequence number (2 T)
- 6 payload (32 T)
- 7 CRC (16 T)
- 8 postamble (2 T)
- 9 P-PDU (66 T)
- a Space (0,5 T).
- b Level adjust (1,5 T).

Figure 6 — P-PDU structure

## 9.2 Space

The space duration shall be 0,5 T with voltage condition OPEN.

### 9.3 Level adjust

Level adjust shall be 1,5 T of 0 Volt.

### 9.4 Pre-amble and Sync

Figure 7 specifies pre-amble and sync patterns. The transmitter shall apply pattern P. If the receiver detects sync pattern P then it shall decode the bits in a P-PDU as positive polarity. If the receiver detects sync pattern Q then it shall decode the bits in a P-PDU as negative polarity. The divisor value shall be detected from pre-amble and sync. Other patterns shall not be handled as pre-amble and sync.

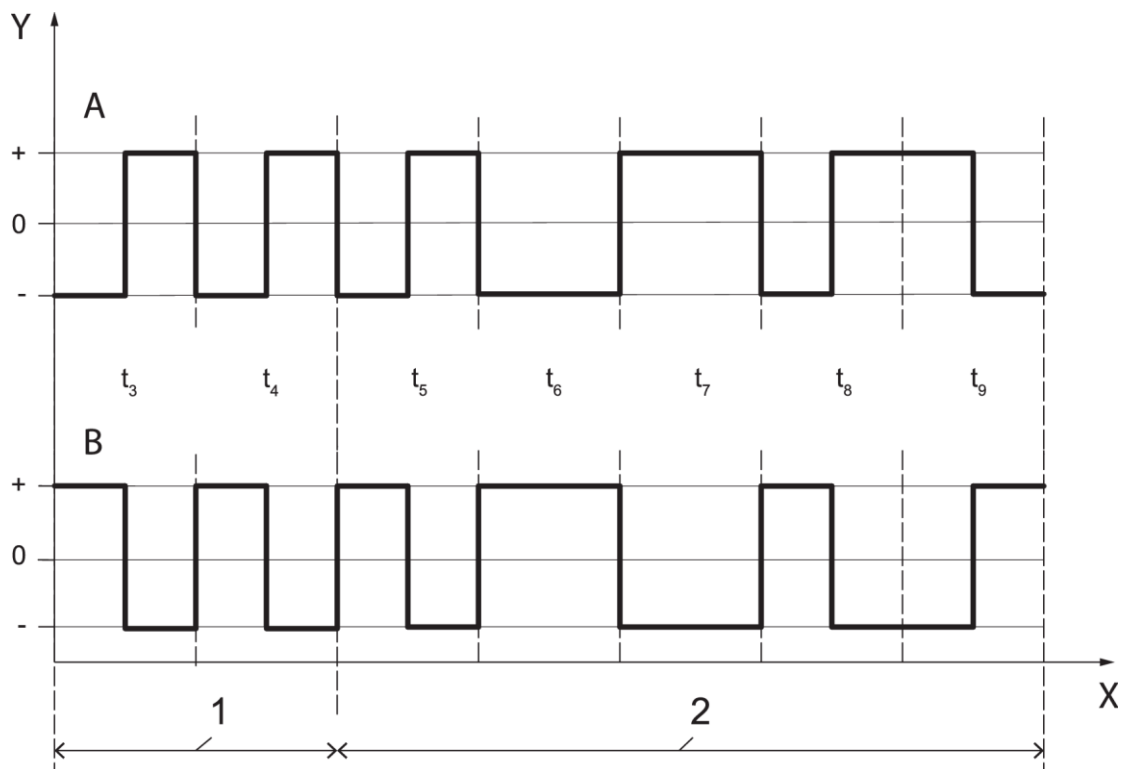

#### Key

1 pre-amble (2 T)

2 sync (5 T)

X time

T bit time

Figure 7 — Pre-amble and sync patterns

### 9.5 Attribute

Table 2 specifies the bit encodings of the attribute settings in a P-PDU. If a receiver gets RFU attribute settings it shall ignore the P-PDU and stay mute.

**Table 2 — Attribute settings**

t <sub>10</sub>	t <sub>11</sub>	Definition	
		FDC2	FDC0, FDC1, FDC3, and FDC4
0	0	Association request 1 or Association response 2	null P-PDU
0	1	Association response 1 or Association request 2	last data P-PDU
1	0	RFU	first data P-PDU
1	1	RFU	data P-PDU between the first and the last data P-PDU

## 9.6 TDS number

The TDS number field shall indicate the slot number in which the P-PDU is send; numbers 1 to 8 are identified by (000)b to (111)b.

## 9.7 Sequence number

### 9.7.1 Initial and range

P-PDUs shall be identified by the sequence numbers in the range of (00)b to (11)b. The first P-PDU shall have (00)b in the sequence number field.

### 9.7.2 Acknowledgement

To acknowledge correct reception, receivers shall increment the sequence number by 1 (modulo 4) from the correctly received P-PDU as the sequence number in the next P-PDU.

## 9.8 Payload

The payload field of a P-PDU contains 4 bytes.

## 9.9 CRC

The scope of CRC shall be the last 1 T of sync as a bit, attribute, TDS number, sequence number, and payload. The CRC shall be calculated according to ITU-T V.41 with pre-set value (FF FF). If the CRC of the received P-PDU and the calculated CRC upon reception differ, the P-DU shall be ignored.

Example: with attribute (11)b, TDS number (010)b, sequence number (10)b, payload (55 AA 00 FF) the CRC is (6F AB).

## 9.10 Post-amble

Post-ambles consist of 1,5 T of level adjust and 0,5 T of Space.

## 9.11 Null P-PDU

Null P-PDUs have attribute of (00)b and a payload (00 00 00 00).

## 9.12 Data P-PDU

Data P-PDUs have a payload with a (possibly segmented) P-DU.



## 10 PHY data unit (P-DU)

Figure 8 specifies the P-DU. It shall consist of LEN, SDU, and CRC.

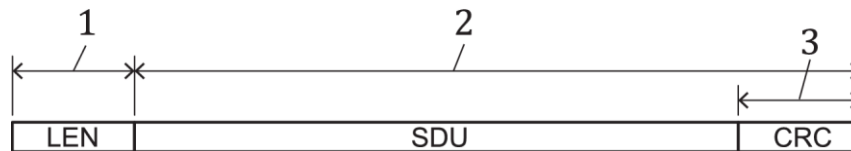

### Key

- 1 2 byte
- 2 LEN bytes
- 3 16 bit

**Figure 8 — PHY data unit (P-DU)**

LEN contains the length of SDU in bytes + 2. The CRC shall be calculated over the LEN value and the SDU according to ITU-T V.41. The pre-set value shall be (FFFF).

## 11 Segmentation and reassembly

P-DU shall be segmented and reassembled into 4 byte payloads of P-PDU as illustrated in Figure 9, by using the attribute settings in Table 2.

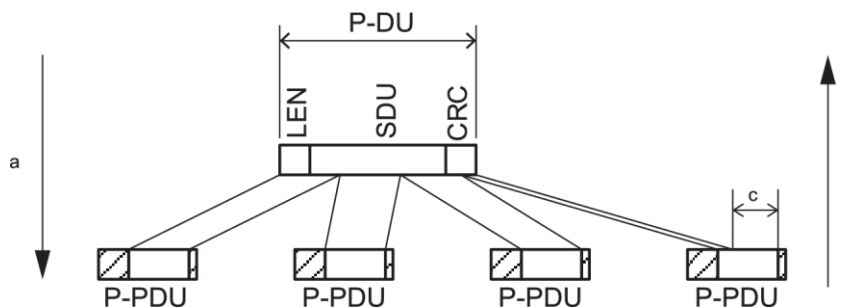

- a Segmentation.
- b Reassembly.
- c Duration to be ignored for information exchange.

**Figure 9 — Segmentation and reassembly**

## 12 TDS

A TDS is 64 T wide. A P-PDU which is 66 T wide (see Figure 6), shall be transmitted in one TDS. See Figure 11.

TDSs shall be numbered from 1 to 8 in each time segment as illustrated in Figure 10.

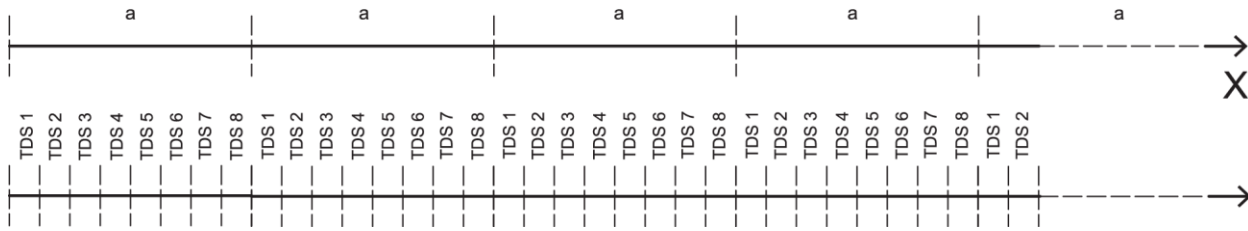

<sup>a</sup> Time-segment.

**Figure 10 — Time-segment and TDS**

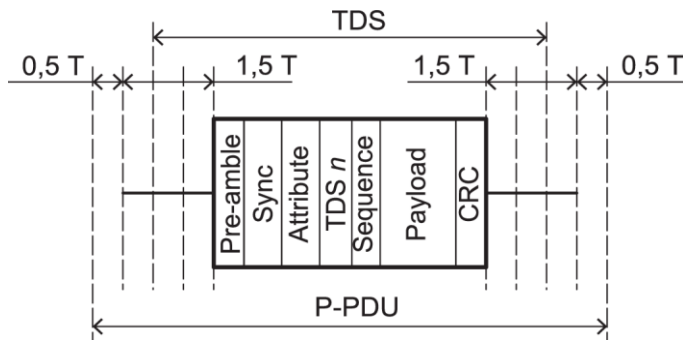

**Figure 11 — Mapping of a P-PDU and a TDS**

This document specifies full duplex and broadcast communication. A TDS is used for unidirectional communication. A full duplex channel consists of two TDSs and one TDS is used for broadcast communication.

The TDS may be either fixed by configuration or be negotiated.

Talkers may either use fixed configured TDS(s) on FDC1 or FDC3 or alternatively negotiate using TDS(s) on FDC1 or FDC3 using the association procedure. Talkers that select FDC0 or FDC4 shall negotiate TDS using the association procedure in Clause 14.

Before using a TDS, entities shall use LBT and synchronisation.

## 13 LBT and synchronisation

### 13.1 LBT

During LBT, entities shall listen for 576 T on the selected FDC to seek a free TDS. A TDS is occupied when the entities receive a correct P-PDU.

### 13.2 Synchronisation

If all TDSs on the FDC that the talker selects are found to be free using LBT, then that talker shall generate the TDS timing on its selected FDC. Otherwise the talkers shall synchronise to the TDS timing on the FDC using LBT. Listeners shall always synchronise to the TDS timing on the FDC using LBT.

## 14 Association procedure

Talkers use the association procedure to negotiate the communication TDS(s). During this procedure, talkers and listeners exchange the P-PDUs on 2 full duplex TDS in FDC2, in the following steps:

- 1) Talker selects a free association TDS in the range from 0 to 3 in FDC2, using LBT.
- 2) Talker selects (1 for broadcast and 2 for full duplex) free slot(s) in an FDC other than FDC2, using LBT.
- 3) Talker sends association request 1 P-PDU specified in Table 3 on the association TDS from step 1 with attribute (00)b, sequence number (00)b and FDC/TDS(s) from step 2 and the selected communication mode.
- 4) Listener sends association response 1 P-PDU specified in Table 4 on the association TDS number + 4 with attribute (01)b, sequence number (01)b and random number.
- 5) Talker sends association request 2 P-PDU specified in Table 4 on the association TDS from step 1 with attribute (01)b, sequence number (10)b and the random number from association response 1.
- 6) Listener sends association response 2 P-PDU specified in Table 3 on the association TDS number + 4 with attribute (00)b, sequence number (11)b and FDC/TDS(s) from association request 1.
- 7) Peers attempt communication as specified in Clause 15 on the FDC/TDS(s) from association request 1.
- 8) If the FDC/TDS(s) from association request 1 are occupied peers may repeat this association procedure.

Figure 12 illustrates steps 3) to 6).

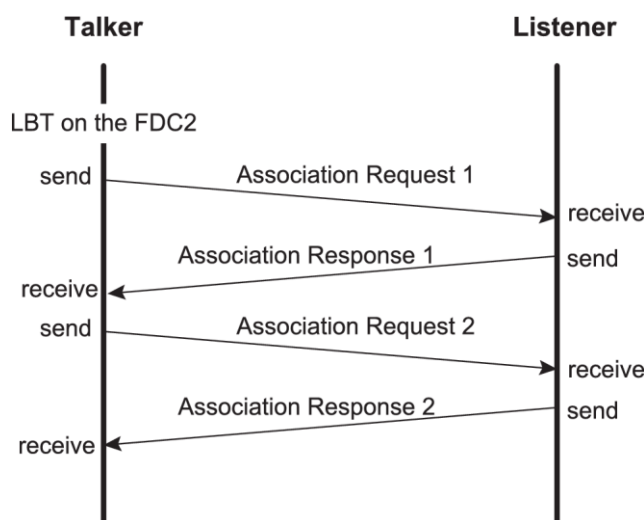

Figure 12 — Association

**Table 3 — Payload with parameters of association request 1 and association response 2 P-PDU**

Payload	Settings																	
t48	Shall be one's complement of t17, t18, t19, t20, t21, t22, t23, t24, t25, t26, t27, t28, t29, t30, t31, t32																	
t47																		
.																		
.																		
.																		
t34																		
t33																		
t32	RFU																	
t31	RFU																	
t30	RFU																	
t29	RFU																	
t28	RFU																	
t27	0	full duplex				0	broadcast				other settings are RFU							
t26	0	communication				1	communication											
t25	0					0												
t24	0	listene r	1	listene r	0	listener	1	listener	0	listener	1	listener	0	listener	1	listene r		
t23	0	uses	0	uses	1	uses	1	uses	0	Uses	0	uses	1	uses	1	uses		
t22	0	TDS 1	0	TDS 2	0	TDS 3	0	TDS 4	1	TDS 5	1	TDS 6	1	TDS 7	1	TDS 8		
t21	0	talker	1	talker	0	talker	1	talker	0	talker	1	talker	0	talker	1	talker		
t20	0	uses	0	uses	1	uses	1	uses	0	Uses	0	uses	1	uses	1	uses		
t19	0	TDS 1	0	TDS 2	0	TDS 3	0	TDS 4	1	TDS 5	1	TDS 6	1	TDS 7	1	TDS 8		
t18	0	use FDC 0				1	use FDC 4				other settings are RFU							
t17	0					1												

**Table 4 — Payload with parameters of association response 1 and association request 2 P-PDU**

Payload	Settings
t <sub>48</sub>	<p data-bbox="421 510 1433 537">Shall be one's complement of t<sub>17</sub>, t<sub>18</sub>, t<sub>19</sub>, t<sub>20</sub>, t<sub>21</sub>, t<sub>22</sub>, t<sub>23</sub>, t<sub>24</sub>, t<sub>25</sub>, t<sub>26</sub>, t<sub>27</sub>, t<sub>28</sub>, t<sub>29</sub>, t<sub>30</sub>, t<sub>31</sub>, t<sub>32</sub></p>
t <sub>47</sub>	
.	
.	
.	
.	
t <sub>34</sub>	
t <sub>33</sub>	
t <sub>32</sub>	<p data-bbox="826 902 1027 929">Random number</p>
t <sub>31</sub>	
.	
.	
.	
.	
t <sub>18</sub>	
t <sub>17</sub>	

## 15 Communication

### 15.1 General

Entities exchange P-PDUs (see Clause 11) using either full duplex or broadcast communication.

Entities shall send Null P-PDUs when there is no P-DU (see Clause 10) pending until the PHY user stops communication.

### 15.2 Full duplex communication

See subclause 9.7.1 for the rules on the sequence numbering.

The sender shall resend the current P-PDU until it is acknowledged. See subclause 9.7.2.

The next P-PDU shall have a sequence number of the (last received sequence number + 1) modulo 4.

Figure 13 illustrates full duplex communication without any errors.

Figure 14 illustrates a full duplex communication flow with receive errors.

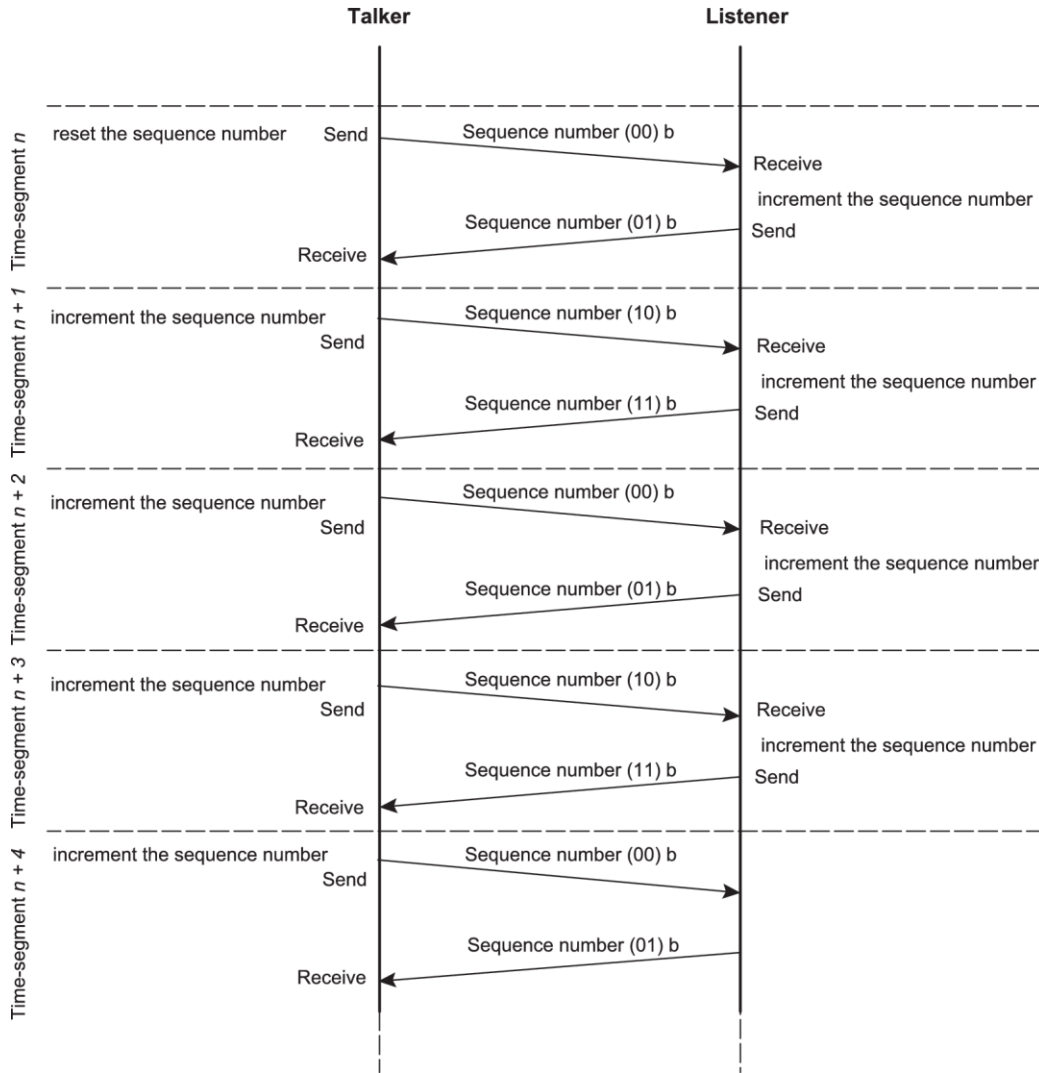

**Figure 13 — Example flow of full duplex communication**

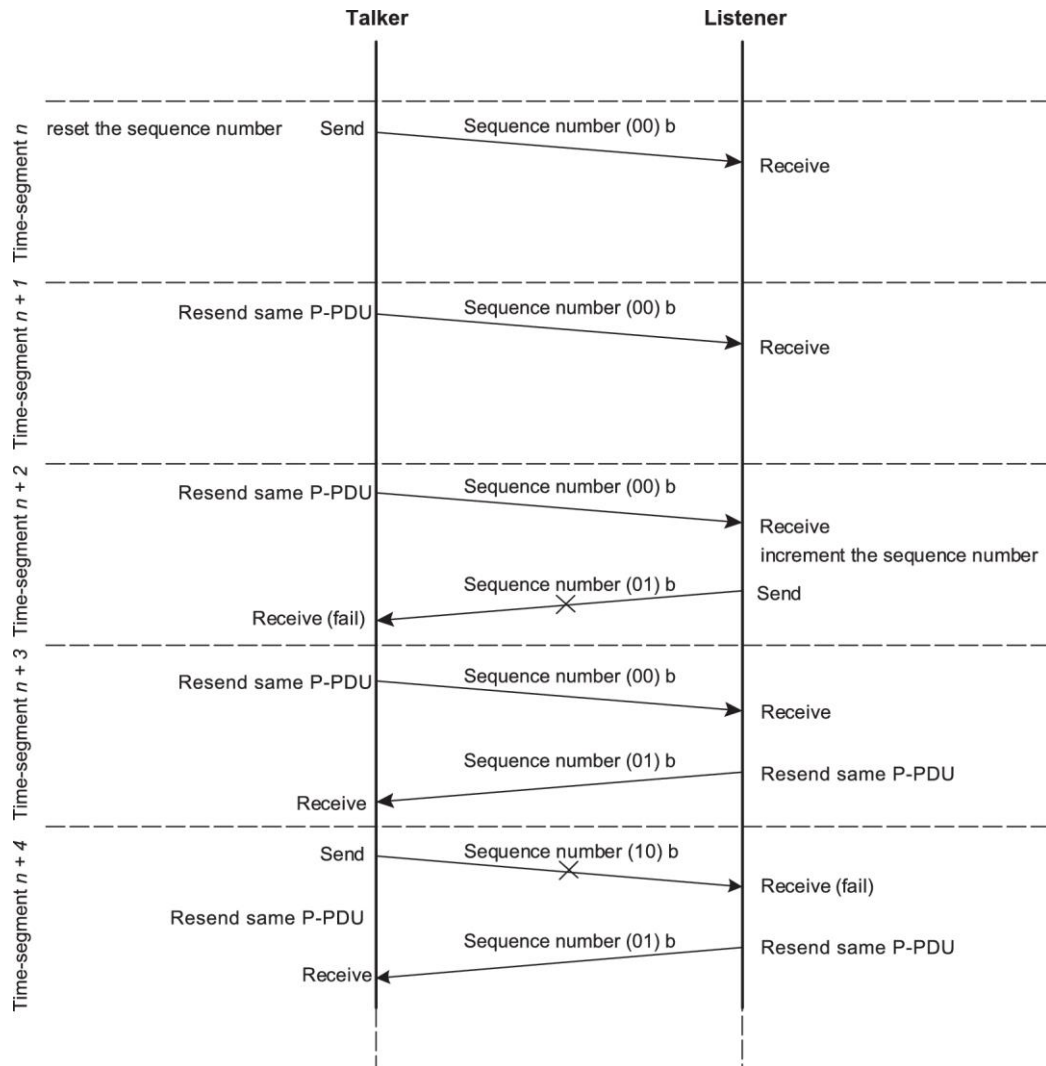

**Figure 14 — Example flow of full duplex communication with some resending**

### 15.3 Broadcast communication

Broadcast communication is unidirectional and unacknowledged.

For broadcast communication, the talker (hereafter referred to as broadcaster) shall use the LBT procedure in subclause 13.1 to find a free TDS on FDC0 or FDC4.

Any numbers of receivers may receive broadcasted P-PDUs.

See subclause 9.7.1 for the rules on the sequence numbering.

The broadcaster may repeatedly send identical P-PDUs. The next P-PDU shall have a sequence number of the (last sent sequence number + 1) modulo 4.

NOTE Repeating identical P-PDUs can increase communication robustness.

Figure 15 illustrates broadcast communication flow. In this example, the broadcaster sends identical P-PDUs in 2 time-segments.

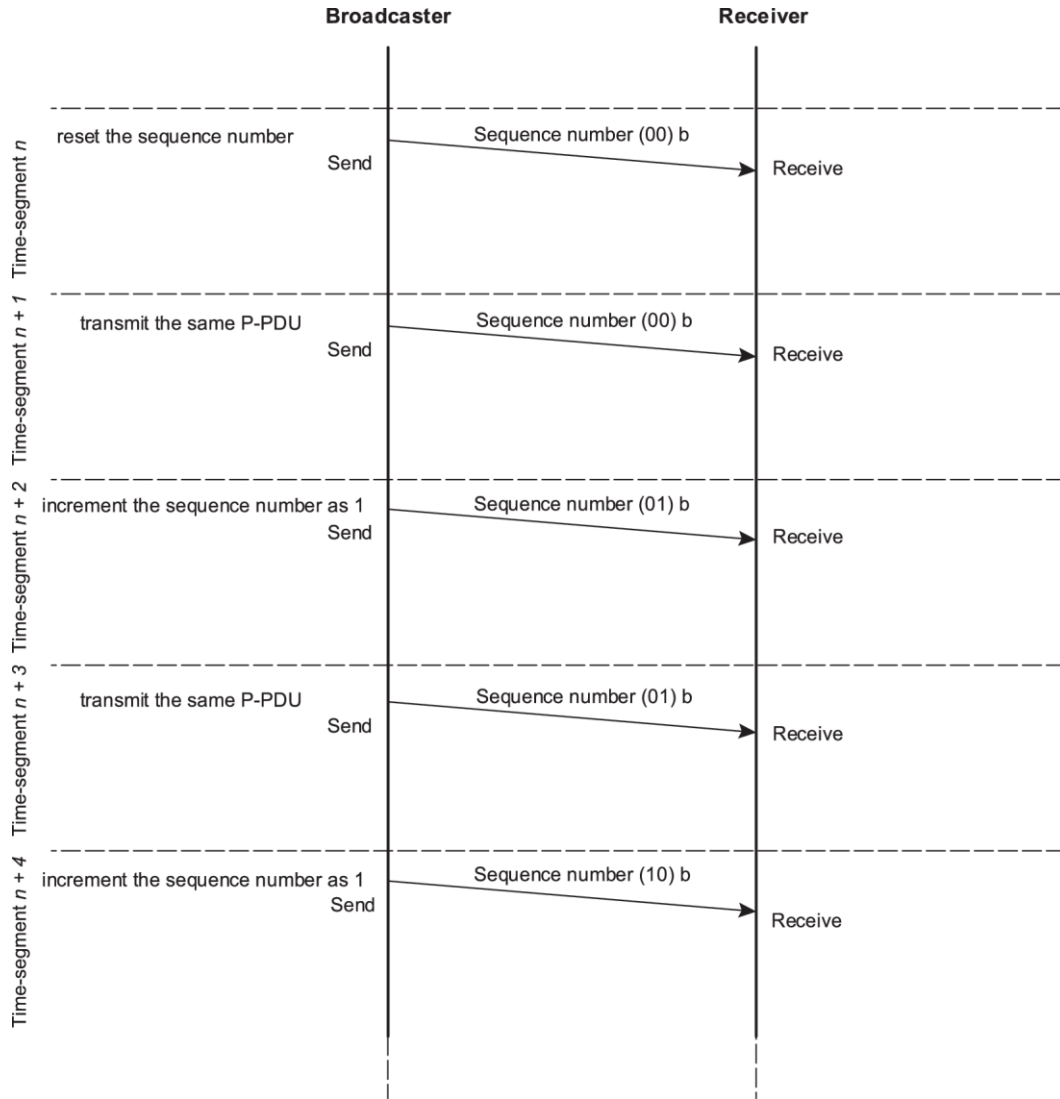

Figure 15 — Example flow of broadcast communication



## Annex A (normative)

### Tests

#### A.1 Reference plate-electrode test

Tests and measurements made to check the requirements of this document shall be carried out in the following ambient conditions of the air immediately surrounding the plate-electrode assemblies:

- Temperature: 20 °C to 30 °C.
- Relative humidity: 40 % to 70 %.
- Conditioning period before testing: at least 1 hour.

The reference plate-electrode assembly shall be horizontally opposed to the plate-electrode assembly for DUT. The plate-electrodes shall be terminated by a 50  $\Omega$  resistor. See Figure A.1.

The power sources of the signal generator and the spectrum analyser shall be electrically isolated from each other.

Any conductive materials without air shall not be in range of 50,0 cm from a plate-electrode assembly. The distance between a plate-electrode assembly and the signal generator shall be from 50,0 cm to 100,0 cm. The distance between a plate-electrode assembly and the spectrum analyser shall be from 50,0 cm to 100,0 cm.

The output and input impedance of the signal generator and the spectrum analyser and the twisted-pair wire shall be terminated by a 50  $\Omega$  resistor.

The output signal level of the signal generator shall be 3,9 dBm of sine wave. The minimum power levels specified in Table A.1 shall be verified at the spectrum analyser for the specified D and distance.

**Table A.1 — Receive power (dBm)**

Distance between the plate-electrode assembly (mm)	fc/D (Mb/s)				
	40,68	13,56	8,14	5,81	3,70
1,0 ± 0,5	- 43	- 55	- 60	- 64	- 68
3,2 ± 0,5	- 47	- 58	- 64	- 67	- 72
10,0 ± 0,5	- 55	- 67	- 73	- 76	- 81
31,6 ± 0,5	- 65	- 78	- 84	- 88	- 94
100,0 ± 0,5	- 81	- 93	- 99	- 103	- 108

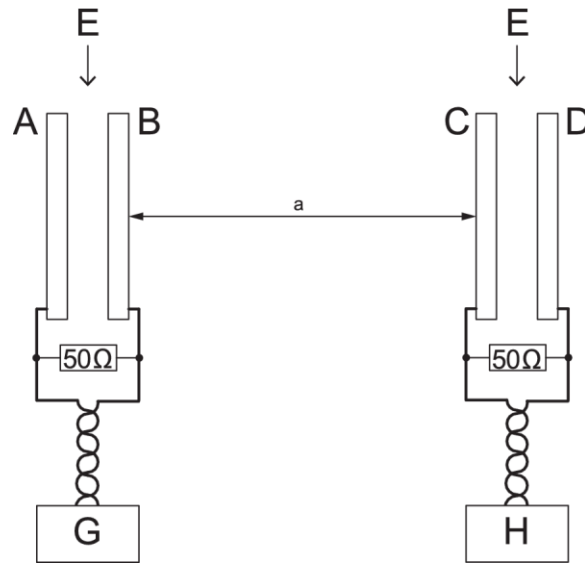

**Key**

a Distance between plate-electrode B and C.

**Components**

- A plate-electrode A
- B plate-electrode B
- C plate-electrode C
- D plate-electrode D
- E reference plate-electrode assembly
- F plate-electrode assembly for DUT

**Equipment**

- G signal generator
- H spectrum analyser

**Figure A.1 — Plate-electrode assembly test**

**A.2 P-PDU DC balance test**

The P-PDUs with payloads (00 00 00 00), (FF FF FF FF), (55 55 55 55) and (AA AA AA AA) shall meet the requirements of DC balance of P-PDU, see 8.4.

**A.3 Protocol test**

Using the protocol test setup, the tests specified herein shall be completed as specified.

**A.3.1 Test setup**

The test setup is illustrated in Figure A.2.

The test box shall be able to send and receive the test P-PDUs. The test box shall execute all the test scenarios regarding DUT.

The protocol test setup shall consist of the reference plate-electrode assembly, test box and DUT. The reference plate-electrode shall be connected to the test box. The distance between plate-electrodes B and C shall be  $10,0 \pm 0,5$  mm.

The power sources of the test box and DUT shall be electrically insulated.

NOTE If the test box and DUT get their power source from the same lamp line, their grounds are connected.

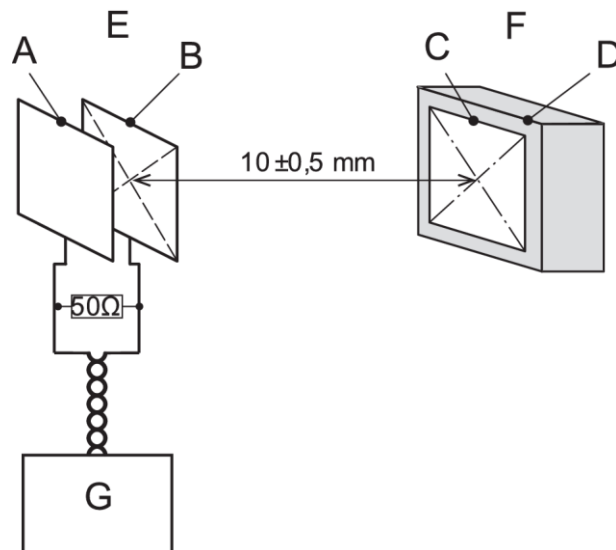

#### Key

##### Components

- A plate-electrode A
- B plate-electrode B
- C plate-electrode C
- D plate-electrode D
- E reference plate-electrode assembly
- F DUT

##### Equipment

- G test box

**Figure A.2 — Protocol test setup**

### A.3.2 Test scenario 1

Test box activates as talker and DUT activates as listener.

The devices are tested on FDC0, TDS1 and TDS5 in full duplex communication with LBT and the association procedure on FDC2, TDS1 and TDS5.

See Table A.2 for details.

### A.3.3 Test scenario 2

Test box activates as talker and DUT activates as listener.

The devices are tested on FDC0, TDS1 in broadcast communication with LBT and the association procedure on FDC2, TDS1 and TDS5.

See Table A.3 for details. Other possible scenarios may be planned.

### **A.3.4 Test scenario 3**

Test box activates as talker and DUT activates as listener.

The devices are tested on FDC1, TDS1 and TDS5 in full duplex communication without an association procedure.

See Table A.4 for details. Other possible scenarios may be planned.

### **A.3.5 Test scenario 4**

Test box activates as talker and DUT activates as listener.

The devices are tested on FDC1, TDS1 in broadcast communication without an association procedure.

See Table A.5 for details. Other possible scenarios may be planned.

### **A.3.6 Test scenario 5**

Test box activates as listener and DUT activates as talker.

The devices are tested on FDC0, TDS1 and TDS5 in full duplex communication with LBT and the association procedure on FDC2, TDS1 and TDS5.

See Table A.6 for details. Other possible scenarios may be planned.

### **A.3.7 Test scenario 6**

Test box activates as listener and DUT activates as talker.

The devices are tested on FDC0, TDS1 in broadcast communication with LBT and the association procedure on FDC2, TDS1 and TDS5.

See Table A.7 for details. Other possible scenarios may be planned.

### **A.3.8 Test scenario 7**

Test box activates as listener and DUT activates as talker.

The devices are tested on FDC1, TDS1 and TDS5 in full duplex communication without an association procedure.

See Table A.8 for details. Other possible scenarios may be planned.

### **A.3.9 Test scenario 8**

Test box activates as listener and DUT activates as talker.

The devices are tested on FDC1, TDS1 in broadcast communication without an association procedure.

See Table A.9 for details. Other possible scenarios may be planned.

Table A.2 — Test scenario 1

Test box with reference plate-electrode assembly	Step number and direction	Device under test (DUT)
<p>&lt; FDC2/TDS1 : Association Request 1 &gt;            Pre-amble/Sync = Pattern P, Attribute = 00,            Sequence number = 00, Payload = (20)(00)(DF)(FF)</p> <p>&lt; FDC2/TDS2 : Association Request 1 &gt;            Pre-amble/Sync = Pattern P, Attribute = 00,            Sequence number = 00, Payload = (00)(00)(FF)(FF)</p> <p>&lt; FDC2/TDS6 : Association Response 1 &gt;            Pre-amble/Sync = Pattern P, Attribute = 00,            Sequence number = 01, Payload = (00)(00)(FF)(FF)</p> <p>&lt; FDC2/TDS3 : Association Request 1 &gt;            Pre-amble/Sync = Pattern P, Attribute = 00,            Sequence number = 00, Payload = (00)(00)(FF)(FF)</p> <p>&lt; FDC2/TDS7 : Association Response 1 &gt;            Pre-amble/Sync = Pattern P, Attribute = 00,            Sequence number = 01, Payload = (00)(00)(FF)(FF)</p> <p>&lt; FDC2/TDS4 : Association Request 1 &gt;            Pre-amble/Sync = Pattern P, Attribute = 00,            Sequence number = 00, Payload = (00)(00)(FF)(FF)</p> <p>&lt; FDC2/TDS8 : Association Response 1 &gt;            Pre-amble/Sync = Pattern P, Attribute = 00,            Sequence number = 01, Payload = (00)(00)(FF)(FF)</p> <p>(Test Box sends Association Request 1 or Association Response 1 on TDSs except TDS5 on FDC2. TDS1 : Used FDC1, talker uses TDS1, listener uses TDS5, Full duplex)</p>	<p>1 →</p>	<p>&lt; FDC2 : LBT &gt;            DUT should be able to detect vacant TDS5 and receive Association Request 1.</p>
	<p>2 ←</p>	<p>&lt; FDC2/TDS5 : Association Response 1 &gt;            Pre-amble/Sync = Pattern P, Attribute = 00,            Sequence number = 01, Payload = (00)(00)(FF)(FF)</p>

Test box with reference plate-electrode assembly	Step number and direction	Device under test (DUT)
<p>&lt; FDC2/TDS1 : Association Request 2 &gt;            Pre-amble/Sync = Pattern P, Attribute = 01,            Sequence number = 10, Payload = (00)(00)(FF)(FF)</p> <p>&lt; FDC2/TDS2 : Association Request 1 &gt;            Pre-amble/Sync = Pattern P, Attribute = 00,            Sequence number = 00, Payload = (00)(00)(FF)(FF)</p> <p>&lt; FDC2/TDS6 : Association Response 1 &gt;            Pre-amble/Sync = Pattern P, Attribute = 01,            Sequence number = 01, Payload = (00)(00)(FF)(FF)</p> <p>&lt; FDC2/TDS3 : Association Request 1 &gt;            Pre-amble/Sync = Pattern P, Attribute = 00,            Sequence number = 00, Payload = (00)(00)(FF)(FF)</p> <p>&lt; FDC2/TDS7 : Association Response 1 &gt;            Pre-amble/Sync = Pattern P, Attribute = 01,            Sequence number = 01, Payload = (00)(00)(FF)(FF)</p> <p>&lt; FDC2/TDS4 : Association Request 1 &gt;            Pre-amble/Sync = Pattern P, Attribute = 00,            Sequence number = 00, Payload = (00)(00)(FF)(FF)</p> <p>&lt; FDC2/TDS8 : Association Response 1 &gt;            Pre-amble/Sync = Pattern P, Attribute = 01,            Sequence number = 01, Payload = (00)(00)(FF)(FF)</p> <p>(Test Box sends Association Request 2 on FDC2/TDS5 from step 1)</p>	<p>3 →</p>	<p>DUT should be able to receive Association Request 2.</p>
	<p>4 ←</p>	<p>&lt; FDC2/TDS5 : Association Response 2 &gt;            Pre-amble/Sync = Pattern P, Attribute = 01,            Sequence number = 11, Payload = (20)(00)(E0)(FF)</p> <p>DUT goes to the next step after detecting the silence of P-PDU on FDC2/TDS1.</p>
<p>&lt; FDC0/TDS1 : Full duplex &gt;            Pre-amble/Sync = Pattern P, Attribute = 10,            Sequence number = 00, Payload = (0A)(00)(55)(AA)</p>	<p>5 →</p>	<p>DUT should be able to receive the P-DU segment on FDC0/TDS1.</p>

Test box with reference plate-electrode assembly	Step number and direction	Device under test (DUT)
<p>&lt; FDC0/TDS2 : Full duplex &gt;            Pre-amble/Sync = Pattern P, Attribute = 00,            Sequence number = 00, Payload = (00)(00)(FF)(FF)</p> <p>&lt; FDC0/TDS6 : Full duplex &gt;            Pre-amble/Sync = Pattern P, Attribute = 00,            Sequence number = 01, Payload = (00)(00)(FF)(FF)</p> <p>&lt; FDC0/TDS3 : Full duplex &gt;            Pre-amble/Sync = Pattern P, Attribute = 00,            Sequence number = 00, Payload = (00)(00)(FF)(FF)</p> <p>&lt; FDC0/TDS7 : Full duplex &gt;            Pre-amble/Sync = Pattern P, Attribute = 00,            Sequence number = 01, Payload = (00)(00)(FF)(FF)</p> <p>&lt; FDC0/TDS4 : Full duplex &gt;            Pre-amble/Sync = Pattern P, Attribute = 00,            Sequence number = 00, Payload = (00)(00)(FF)(FF)</p> <p>&lt; FDC0/TDS8 : Full duplex &gt;            Pre-amble/Sync = Pattern P, Attribute = 00,            Sequence number = 01, Payload = (00)(00)(FF)(FF)</p> <p>(Test Box sends the first P-DU segment on TDS1 on FDC2)</p>		
	6 ←	<p>&lt; FDC0/TDS5 : Full duplex &gt;            Pre-amble/Sync = Pattern P, Attribute = 10,            Sequence number = 01, Payload = (0A)(00)(55)(AA)            (DUT send back the payload)</p>
<p>&lt; FDC0/TDS1 : Full duplex &gt;            Pre-amble/Sync = Pattern P, Attribute = 11,            Sequence number = 10, Payload = (00)(FF)(C3)(E7)</p> <p>&lt; FDC0/TDS2 : Full duplex &gt;            Pre-amble/Sync = Pattern P, Attribute = 00,            Sequence number = 00, Payload = (00)(00)(FF)(FF)</p>	7 →	<p>DUT should be able to receive the P-DU segment on FDC0/TDS1.</p>

Test box with reference plate-electrode assembly	Step number and direction	Device under test (DUT)
<p>&lt; FDC0/TDS6 : Full duplex &gt;            Pre-amble/Sync = Pattern P, Attribute = 00,            Sequence number = 01, Payload = (00)(00)(FF)(FF)</p> <p>&lt; FDC0/TDS3 : Full duplex &gt;            Pre-amble/Sync = Pattern P, Attribute = 00,            Sequence number = 00, Payload = (00)(00)(FF)(FF)</p> <p>&lt; FDC0/TDS7 : Full duplex &gt;            Pre-amble/Sync = Pattern P, Attribute = 00,            Sequence number = 01, Payload = (00)(00)(FF)(FF)</p> <p>&lt; FDC0/TDS4 : Full duplex &gt;            Pre-amble/Sync = Pattern P, Attribute = 00,            Sequence number = 00, Payload = (00)(00)(FF)(FF)</p> <p>&lt; FDC0/TDS8 : Full duplex &gt;            Pre-amble/Sync = Pattern P, Attribute = 00,            Sequence number = 01, Payload = (00)(00)(FF)(FF)</p> <p>(Test Box sends the between P-DU segment on TDS1 on FDC2 from step 4)</p>		
	8 ←	<p>&lt; FDC0/TDS5 : Full duplex &gt;            Pre-amble/Sync = Pattern P, Attribute = 11,            Sequence number = 11, Payload = (00)(FF)(C3)(E7)            (DUT send back the payload)</p>
<p>&lt; FDC0/TDS1 : Full duplex &gt;            Pre-amble/Sync = Pattern P, Attribute = 01,            Sequence number = 00, Payload = (96)(42)(B0)(4A)</p> <p>&lt; FDC0/TDS2 : Full duplex &gt;            Pre-amble/Sync = Pattern P, Attribute = 00,            Sequence number = 00, Payload = (00)(00)(FF)(FF)</p> <p>&lt; FDC0/TDS6 : Full duplex &gt;            Pre-amble/Sync = Pattern P, Attribute = 00,            Sequence number = 01, Payload = (00)(00)(FF)(FF)</p>	9 →	<p>DUT should be able to receive the P-DU segment on FDC0/TDS1.</p>



Test box with reference plate-electrode assembly	Step number and direction	Device under test (DUT)
<p>&lt; FDC0/TDS3 : Full duplex &gt;            Pre-amble/Sync = Pattern P, Attribute = 00,            Sequence number = 00, Payload = (00)(00)(FF)(FF)</p> <p>&lt; FDC0/TDS7 : Full duplex &gt;            Pre-amble/Sync = Pattern P, Attribute = 00,            Sequence number = 01, Payload = (00)(00)(FF)(FF)</p> <p>&lt; FDC0/TDS4 : Full duplex &gt;            Pre-amble/Sync = Pattern P, Attribute = 00,            Sequence number = 00, Payload = (00)(00)(FF)(FF)</p> <p>&lt; FDC0/TDS8 : Full duplex &gt;            Pre-amble/Sync = Pattern P, Attribute = 00,            Sequence number = 01, Payload = (00)(00)(FF)(FF)</p> <p>(Test Box sends Full duplex P-PDU on TDS5 on FDC2 from step 4)</p>		
	10 ←	<p>&lt; FDC0/TDS5 : Full duplex &gt;            Pre-amble/Sync = Pattern P, Attribute = 01,            Sequence number = 01, Payload = (96)(42)(B0)(4A)            (DUT send back the payload)</p>

**Table A.3 — Test scenario 2**

Test box with reference plate-electrode assembly	Step number and direction	Device under test (DUT)
<p>&lt; FDC2/TDS1 : Association Request 1 &gt;            Pre-amble/Sync = Pattern P, Attribute = 00,            Sequence number = 00, Payload = (00)(02)(FF)(FD)</p> <p>&lt; FDC2/TDS2 : Association Request 1 &gt;            Pre-amble/Sync = Pattern P, Attribute = 00,            Sequence number = 00, Payload = (00)(00)(FF)(FF)</p> <p>&lt; FDC2/TDS6 : Association Response 1 &gt;            Pre-amble/Sync = Pattern P, Attribute = 01,            Sequence number = 01, Payload = (00)(00)(FF)(FF)</p> <p>&lt; FDC2/TDS3 : Association Request 1 &gt;            Pre-amble/Sync = Pattern P, Attribute = 00,            Sequence number = 00, Payload = (00)(00)(FF)(FF)</p> <p>&lt; FDC2/TDS7 : Association Response 1 &gt;            Pre-amble/Sync = Pattern P, Attribute = 01,            Sequence number = 01, Payload = (00)(00)(FF)(FF)</p> <p>&lt; FDC2/TDS4 : Association Request 1 &gt;            Pre-amble/Sync = Pattern P, Attribute = 00,            Sequence number = 00, Payload = (00)(00)(FF)(FF)</p> <p>&lt; FDC2/TDS8 : Association Response 1 &gt;            Pre-amble/Sync = Pattern P, Attribute = 01,            Sequence number = 01, Payload = (00)(00)(FF)(FF)</p> <p>(Test Box sends Association Request 1 or Association Response 1 on TDSs except TDS1 and TDS5 on FDC2. TDS1 : Used FDC1, talker uses TDS1, listener uses TDS5, Broadcast)</p>	<p>1 →</p>	<p>&lt; FDC2 : LBT &gt;            DUT should be able to detect the vacant TDS5 on FDC2 and receive Association Request 1.</p>
	<p>2 ←</p>	<p>&lt; FDC2/TDS5 : Association Response 1 &gt;            Pre-amble/Sync = Pattern P, Attribute = 00,            Sequence number = 01, Payload = (00)(00)(FF)(FF)</p>
<p>&lt; FDC2/TDS1 : Association Request 2 &gt;            Pre-amble/Sync = Pattern P, Attribute = 01,</p>	<p>3 →</p>	<p>DUT should be able to receive Association Request 1.</p>

Test box with reference plate-electrode assembly	Step number and direction	Device under test (DUT)
<p>Sequence number = 10, Payload = (00)(00)(FF)(FF)</p> <p>&lt; FDC2/TDS2 : Association Request 1 &gt;</p> <p>Pre-amble/Sync = Pattern P, Attribute = 00,</p> <p>Sequence number = 00, Payload = (00)(00)(FF)(FF)</p> <p>&lt; FDC2/TDS6 : Association Response 1 &gt;</p> <p>Pre-amble/Sync = Pattern P, Attribute = 01,</p> <p>Sequence number = 01, Payload = (00)(00)(FF)(FF)</p> <p>&lt; FDC2/TDS3 : Association Request 1 &gt;</p> <p>Pre-amble/Sync = Pattern P, Attribute = 00,</p> <p>Sequence number = 00, Payload = (00)(00)(FF)(FF)</p> <p>&lt; FDC2/TDS7 : Association Response 1 &gt;</p> <p>Pre-amble/Sync = Pattern P, Attribute = 01,</p> <p>Sequence number = 01, Payload = (00)(00)(FF)(FF)</p> <p>&lt; FDC2/TDS4 : Association Request 1 &gt;</p> <p>Pre-amble/Sync = Pattern P, Attribute = 00,</p> <p>Sequence number = 00, Payload = (00)(00)(FF)(FF)</p> <p>&lt; FDC2/TDS8 : Association Response 1 &gt;</p> <p>Pre-amble/Sync = Pattern P, Attribute = 01,</p> <p>Sequence number = 01, Payload = (00)(00)(FF)(FF)</p> <p>(Test Box sends Association Response 1 on FDC2/TDS5 from step 1)</p>		
	<p>4</p> <p>←</p>	<p>&lt; FDC2/TDS5 : Association Response 2 &gt;</p> <p>Pre-amble/Sync = Pattern P, Attribute = 01,</p> <p>Sequence number = 11, Payload = (00)(02)(00)(FE)</p> <p>DUT goes to the next step after detecting the silence of P-PDU on FDC2/TDS1.</p>
<p>&lt; FDC0/TDS1 : Broadcast &gt;</p> <p>Pre-amble/Sync = Pattern P, Attribute = 10,</p> <p>Sequence number = 00, Payload = (0A)(00)(55)(AA)</p> <p>— Check iteration count function</p>	<p>5</p> <p>→</p>	<p>DUT should be able to receive the P-DU segment on FDC0/TDS1 for iteration count.</p>

Test box with reference plate-electrode assembly	Step number and direction	Device under test (DUT)
<p>(Test Box sends the first P-DU segment iteration count times)</p> <p>&lt; FDC0/TDS2 : Broadcast &gt; Pre-amble/Sync = Pattern P, Attribute = 00, Sequence number = 00, Payload = (00)(00)(FF)(FF)</p> <p>&lt; FDC0/TDS3 : Broadcast &gt; Pre-amble/Sync = Pattern P, Attribute = 00, Sequence number = 00, Payload = (00)(00)(FF)(FF)</p> <p>&lt; FDC0/TDS4 : Broadcast &gt; Pre-amble/Sync = Pattern P, Attribute = 00, Sequence number = 00, Payload = (00)(00)(FF)(FF)</p> <p>&lt; FDC0/TDS5 : Broadcast &gt; Pre-amble/Sync = Pattern P, Attribute = 00, Sequence number = 00, Payload = (00)(00)(FF)(FF)</p> <p>&lt; FDC0/TDS6 : Broadcast &gt; Pre-amble/Sync = Pattern P, Attribute = 00, Sequence number = 00, Payload = (00)(00)(FF)(FF)</p> <p>&lt; FDC0/TDS7 : Broadcast &gt; Pre-amble/Sync = Pattern P, Attribute = 00, Sequence number = 00, Payload = (00)(00)(FF)(FF)</p> <p>&lt; FDC0/TDS8 : Broadcast &gt; Pre-amble/Sync = Pattern P, Attribute = 00, Sequence number = 00, Payload = (00)(00)(FF)(FF)</p>		
<p>&lt; FDC0/TDS1 : Broadcast &gt; Pre-amble/Sync = Pattern P, Attribute = 11, Sequence number = 01, Payload = (00)(FF)(C3)(E7)</p> <p>— Check iteration count function</p> <p>(Test Box sends the between P-DU segment iteration count times)</p> <p>&lt; FDC0/TDS2 : Broadcast &gt; Pre-amble/Sync = Pattern P, Attribute = 00,</p>	<p>6 →</p>	<p>DUT should be able to receive the P-DU segment on FDC0/TDS1 for iteration count.</p>

Test box with reference plate-electrode assembly	Step number and direction	Device under test (DUT)
<p>Sequence number = 00, Payload = (00)(00)(FF)(FF)</p> <p>&lt; FDC0/TDS3 : Broadcast &gt;</p> <p>Pre-amble/Sync = Pattern P, Attribute = 00,</p> <p>Sequence number = 00, Payload = (00)(00)(FF)(FF)</p> <p>&lt; FDC0/TDS4 : Broadcast &gt;</p> <p>Pre-amble/Sync = Pattern P, Attribute = 00,</p> <p>Sequence number = 00, Payload = (00)(00)(FF)(FF)</p> <p>&lt; FDC0/TDS5 : Broadcast &gt;</p> <p>Pre-amble/Sync = Pattern P, Attribute = 00,</p> <p>Sequence number = 00, Payload = (00)(00)(FF)(FF)</p> <p>&lt; FDC0/TDS6 : Broadcast &gt;</p> <p>Pre-amble/Sync = Pattern P, Attribute = 00,</p> <p>Sequence number = 00, Payload = (00)(00)(FF)(FF)</p> <p>&lt; FDC0/TDS7 : Broadcast &gt;</p> <p>Pre-amble/Sync = Pattern P, Attribute = 00,</p> <p>Sequence number = 00, Payload = (00)(00)(FF)(FF)</p> <p>&lt; FDC0/TDS8 : Broadcast &gt;</p> <p>Pre-amble/Sync = Pattern P, Attribute = 00,</p> <p>Sequence number = 00, Payload = (00)(00)(FF)(FF)</p>		
<p>&lt; FDC0/TDS1 Full duplex &gt;</p> <p>Pre-amble/Sync = Pattern P, Attribute = 01,</p> <p>Sequence number = 10, Payload = (96)(42)(B0)(4A)</p> <p>— Check iteration count function</p> <p>(Test Box sends the last P-DU segment iteration count times)</p> <p>&lt; FDC0/TDS2 : Broadcast &gt;</p> <p>Pre-amble/Sync = Pattern P, Attribute = 00,</p> <p>Sequence number = 00, Payload = (00)(00)(FF)(FF)</p> <p>&lt; FDC0/TDS3 : Broadcast &gt;</p> <p>Pre-amble/Sync = Pattern P, Attribute = 00,</p>	<p>7</p> <p>→</p>	<p>DUT should be able to receive the P-DU segment on FDC0/TDS1 for iteration count.</p>

Test box with reference plate-electrode assembly	Step number and direction	Device under test (DUT)
<p>Sequence number = 00, Payload = (00)(00)(FF)(FF)</p> <p>&lt; FDC0/TDS4 : Broadcast &gt;</p> <p>Pre-amble/Sync = Pattern P, Attribute = 00,</p> <p>Sequence number = 00, Payload = (00)(00)(FF)(FF)</p> <p>&lt; FDC0/TDS5 : Broadcast &gt;</p> <p>Pre-amble/Sync = Pattern P, Attribute = 00,</p> <p>Sequence number = 00, Payload = (00)(00)(FF)(FF)</p> <p>&lt; FDC0/TDS6 : Broadcast &gt;</p> <p>Pre-amble/Sync = Pattern P, Attribute = 00,</p> <p>Sequence number = 00, Payload = (00)(00)(FF)(FF)</p> <p>&lt; FDC0/TDS7 : Broadcast &gt;</p> <p>Pre-amble/Sync = Pattern P, Attribute = 00,</p> <p>Sequence number = 00, Payload = (00)(00)(FF)(FF)</p> <p>&lt; FDC0/TDS8 : Broadcast &gt;</p> <p>Pre-amble/Sync = Pattern P, Attribute = 00,</p> <p>Sequence number = 00, Payload = (00)(00)(FF)(FF)</p>		

**Table A.4 — Test scenario 3**

Test box with reference plate-electrode assembly	Step number and direction	Device under test (DUT)
<p>&lt; FDC1/TDS1 : Full duplex &gt;            Pre-amble/Sync = Pattern P, Attribute = 10,            Sequence number = 00, Payload = (0A)(00)(55)(AA)</p> <p>&lt; FDC1/TDS2 : Full duplex &gt;            Pre-amble/Sync = Pattern P, Attribute = 00,            Sequence number = 00, Payload = (00)(00)(FF)(FF)</p> <p>&lt; FDC1/TDS6 : Full duplex &gt;            Pre-amble/Sync = Pattern P, Attribute = 00,            Sequence number = 01, Payload = (00)(00)(FF)(FF)</p> <p>&lt; FDC1/TDS3 : Full duplex &gt;            Pre-amble/Sync = Pattern P, Attribute = 00,            Sequence number = 00, Payload = (00)(00)(FF)(FF)</p> <p>&lt; FDC1/TDS7 : Full duplex &gt;            Pre-amble/Sync = Pattern P, Attribute = 00,            Sequence number = 01, Payload = (00)(00)(FF)(FF)</p> <p>&lt; FDC1/TDS4 : Full duplex &gt;            Pre-amble/Sync = Pattern P, Attribute = 00,            Sequence number = 00, Payload = (00)(00)(FF)(FF)</p> <p>&lt; FDC1/TDS8 : Full duplex &gt;            Pre-amble/Sync = Pattern P, Attribute = 00,            Sequence number = 01, Payload = (00)(00)(FF)(FF)</p> <p>(Test Box sends the first P-DU segment on TDS1 except on FDC0)</p>	<p>1 →</p>	<p>Supposing that DUT knows TDS5 as its time-slot.            DUT should be able to receive the P-DU segment on FDC0/TDS1.</p>
	<p>2 ←</p>	<p>&lt; FDC1/TDS5 : Full duplex &gt;            Pre-amble/Sync = Pattern P, Attribute = 00,            Sequence number = 01, Payload = (0A)(00)(55)(AA)            (DUT send back the payload)</p>

Test box with reference plate-electrode assembly	Step number and direction	Device under test (DUT)
<p>&lt; FDC1/TDS1 : Full duplex &gt;            Pre-amble/Sync = Pattern P, Attribute = 11,            Sequence number = 10, Payload = (00)(FF)(C3)(E7)</p> <p>&lt; FDC1/TDS2 : Full duplex &gt;            Pre-amble/Sync = Pattern P, Attribute = 00,            Sequence number = 00, Payload = (00)(00)(FF)(FF)</p> <p>&lt; FDC1/TDS6 : Full duplex &gt;            Pre-amble/Sync = Pattern P, Attribute = 00,            Sequence number = 01, Payload = (00)(00)(FF)(FF)</p> <p>&lt; FDC1/TDS3 : Full duplex &gt;            Pre-amble/Sync = Pattern P, Attribute = 00,            Sequence number = 00, Payload = (00)(00)(FF)(FF)</p> <p>&lt; FDC1/TDS7 : Full duplex &gt;            Pre-amble/Sync = Pattern P, Attribute = 00,            Sequence number = 01, Payload = (00)(00)(FF)(FF)</p> <p>&lt; FDC1/TDS4 : Full duplex &gt;            Pre-amble/Sync = Pattern P, Attribute = 00,            Sequence number = 00, Payload = (00)(00)(FF)(FF)</p> <p>&lt; FDC1/TDS8 : Full duplex &gt;            Pre-amble/Sync = Pattern P, Attribute = 00,            Sequence number = 01, Payload = (00)(00)(FF)(FF)</p> <p>(Test Box sends Full duplex P-PDU on TDS5 on FDC2 from step 4)</p>	<p>3 →</p>	<p>DUT should be able to receive the P-DU segment on FDC0/TDS1.</p>
	<p>4 ←</p>	<p>&lt; FDC1/TDS5 : Full duplex &gt;            Pre-amble/Sync = Pattern P, Attribute = 11,            Sequence number = 11, Payload = (00)(FF)(C3)(E7)            (DUT send back the payload)</p>
<p>&lt; FDC1/TDS1 : Full duplex &gt;            Pre-amble/Sync = Pattern P, Attribute = 01,            Sequence number = 00, Payload = (96)(42)(B0)(4A)</p>	<p>5 →</p>	<p>DUT should be able to receive the P-DU segment on FDC0/TDS1.</p>



Test box with reference plate-electrode assembly	Step number and direction	Device under test (DUT)
<p>&lt; FDC1/TDS2 : Full duplex &gt;            Pre-amble/Sync = Pattern P, Attribute = 00,            Sequence number = 00, Payload = (00)(00)(FF)(FF)</p> <p>&lt; FDC1/TDS6 : Full duplex &gt;            Pre-amble/Sync = Pattern P, Attribute = 00,            Sequence number = 01, Payload = (00)(00)(FF)(FF)</p> <p>&lt; FDC1/TDS3 : Full duplex &gt;            Pre-amble/Sync = Pattern P, Attribute = 00,            Sequence number = 00, Payload = (00)(00)(FF)(FF)</p> <p>&lt; FDC1/TDS7 : Full duplex &gt;            Pre-amble/Sync = Pattern P, Attribute = 00,            Sequence number = 01, Payload = (00)(00)(FF)(FF)</p> <p>&lt; FDC1/TDS4 : Full duplex &gt;            Pre-amble/Sync = Pattern P, Attribute = 00,            Sequence number = 00, Payload = (00)(00)(FF)(FF)</p> <p>&lt; FDC1/TDS8 : Full duplex &gt;            Pre-amble/Sync = Pattern P, Attribute = 00,            Sequence number = 01, Payload = (00)(00)(FF)(FF)</p> <p>(Test Box sends Full duplex P-PDU on TDS5 on FDC2 from step 4)</p>		
	6 ←	<p>&lt; FDC1/TDS5 : Full duplex &gt;            Pre-amble/Sync = Pattern P, Attribute = 01,            Sequence number = 01, Payload = (96)(42)(B0)(4A)            (DUT send back the payload)</p>

**Table A.5 — Test scenario 4**

Test box with reference plate-electrode assembly	Step number and direction	Device under test (DUT)
<p>&lt; FDC1/TDS1 : Broadcast &gt;            Pre-amble/Sync = Pattern P, Attribute = 10,            Sequence number = 00, Payload = (0A)(00)(55)(AA)            — Check iteration count function            (Test Box sends the first P-DU segment iteration count times)</p>	<p>1 →</p>	<p>(Test Box sends same P-PDUs and DUT checks to receive the P-PDU from Test Box with iteration count)</p>
<p>&lt; FDC1/TDS1 : Broadcast &gt;            Pre-amble/Sync = Pattern P, Attribute = 11,            Sequence number = 01, Payload = (00)(FF)(C3)(E7)            — Check iteration count function            (Test Box sends the between P-DU segment iteration count times)</p>	<p>2 →</p>	<p>(Test Box sends same P-PDUs and DUT checks to receive the P-PDU from Test Box with iteration count)</p>
<p>&lt; FDC1/TDS1 : Broadcast &gt;            Pre-amble/Sync = Pattern P, Attribute = 01,            Sequence number = 10, Payload = (96)(42)(B0)(4A)            — Check iteration count function            (Test Box sends the last P-DU segment iteration count times)</p>	<p>3 →</p>	<p>(Test Box sends same P-PDUs and DUT checks to receive the P-PDU from Test Box with iteration count)</p>

Table A.6 — Test scenario 5

Test box with reference plate-electrode assembly	Step number and direction	Device under test (DUT)
<p>&lt; FDC2/TDS1 : Association Request 1 &gt;            Pre-amble/Sync = Pattern P, Attribute = 00,            Sequence number = 00, Payload = (00)(00)(FF)(FF)</p> <p>&lt; FDC2/TDS5 : Association Response 1 &gt;            Pre-amble/Sync = Pattern P, Attribute = 01,            Sequence number = 01, Payload = (00)(00)(FF)(FF)</p> <p>&lt; FDC2/TDS2 : Association Request 1 &gt;            Pre-amble/Sync = Pattern P, Attribute = 00,            Sequence number = 00, Payload = (00)(00)(FF)(FF)</p> <p>&lt; FDC2/TDS6 : Association Response 1 &gt;            Pre-amble/Sync = Pattern P, Attribute = 01,            Sequence number = 01, Payload = (00)(00)(FF)(FF)</p> <p>&lt; FDC2/TDS3 : Association Request 1 &gt;            Pre-amble/Sync = Pattern P, Attribute = 00,            Sequence number = 00, Payload = (00)(00)(FF)(FF)</p> <p>&lt; FDC2/TDS7 : Association Response 1 &gt;            Pre-amble/Sync = Pattern P, Attribute = 01,            Sequence number = 01, Payload = (00)(00)(FF)(FF)</p> <p>&lt; FDC2/TDS4 : Association Request 1 &gt;            Pre-amble/Sync = Pattern P, Attribute = 00,            Sequence number = 00, Payload = (00)(00)(FF)(FF)</p> <p>&lt; FDC2/TDS8 : Association Response 1 &gt;            Pre-amble/Sync = Pattern P, Attribute = 01,            Sequence number = 01, Payload = (00)(00)(FF)(FF)</p> <p>(Test Box sends Association Request 1 or Association Response 1 on all TDSs on FDC3)</p>	<p>1 →</p>	<p>&lt; FDC2 : LBT &gt;            DUT should be able to detect all occupied TDSs on FDC2.</p>
<p>&lt; FDC0/TDS1 : Full duplex &gt;            Pre-amble/Sync = Pattern P, Attribute = 00,            Sequence number = 00, Payload = (00)(00)(FF)(FF)</p>	<p>2 →</p>	<p>&lt; FDC0 : LBT &gt;            DUT should be able to detect all occupied TDSs on FDC0.</p>

Test box with reference plate-electrode assembly	Step number and direction	Device under test (DUT)
<p>&lt; FDC0/TDS5 : Full duplex &gt;            Pre-amble/Sync = Pattern P, Attribute = 00,            Sequence number = 01, Payload = (00)(00)(FF)(FF)</p> <p>&lt; FDC0/TDS2 : Full duplex &gt;            Pre-amble/Sync = Pattern P, Attribute = 00,            Sequence number = 00, Payload = (00)(00)(FF)(FF)</p> <p>&lt; FDC0/TDS6 : Full duplex &gt;            Pre-amble/Sync = Pattern P, Attribute = 00,            Sequence number = 01, Payload = (00)(00)(FF)(FF)</p> <p>&lt; FDC0/TDS3 : Full duplex &gt;            Pre-amble/Sync = Pattern P, Attribute = 00,            Sequence number = 00, Payload = (00)(00)(FF)(FF)</p> <p>&lt; FDC0/TDS7 : Full duplex &gt;            Pre-amble/Sync = Pattern P, Attribute = 00,            Sequence number = 01, Payload = (00)(00)(FF)(FF)</p> <p>&lt; FDC0/TDS4 : Full duplex &gt;            Pre-amble/Sync = Pattern P, Attribute = 00,            Sequence number = 00, Payload = (00)(00)(FF)(FF)</p> <p>&lt; FDC0/TDS8 : Full duplex &gt;            Pre-amble/Sync = Pattern P, Attribute = 00,            Sequence number = 01, Payload = (00)(00)(FF)(FF)</p> <p>(Test Box sends Full duplex P-PDUs on all TDSs on FDC0)</p>		
<p>&lt; FDC2/TDS2 : Association Request 1 &gt;            Pre-amble/Sync = Pattern P, Attribute = 00,            Sequence number = 00, Payload = (00)(00)(FF)(FF)</p> <p>&lt; FDC2/TDS6 : Association Response 1 &gt;            Pre-amble/Sync = Pattern P, Attribute = 01,            Sequence number = 01, Payload = (00)(00)(FF)(FF)</p> <p>&lt; FDC2/TDS3 : Association Request 1 &gt;</p>	<p>3 →</p>	<p>&lt; FDC2 : LBT &gt;            DUT should be able to detect the vacant TDS1 and TDS5 on FDC2.</p>

Test box with reference plate-electrode assembly	Step number and direction	Device under test (DUT)
<p>Pre-amble/Sync = Pattern P, Attribute = 00, Sequence number = 00, Payload = (00)(00)(FF)(FF)</p> <p>&lt; FDC2/TDS7 : Association Response 1 &gt;</p> <p>Pre-amble/Sync = Pattern P, Attribute = 01, Sequence number = 01, Payload = (00)(00)(FF)(FF)</p> <p>&lt; FDC2/TDS4 : Association Request 1 &gt;</p> <p>Pre-amble/Sync = Pattern P, Attribute = 00, Sequence number = 00, Payload = (00)(00)(FF)(FF)</p> <p>&lt; FDC2/TDS8 : Association Response 1 &gt;</p> <p>Pre-amble/Sync = Pattern P, Attribute = 01, Sequence number = 01, Payload = (00)(00)(FF)(FF)</p> <p>(Test Box sends Association Request 1 or Association Response 1 on TDSs except TDS1 and TDS5 on FDC2)</p>		
<p>&lt; FDC0/TDS2 : Full duplex &gt;</p> <p>Pre-amble/Sync = Pattern P, Attribute = 00, Sequence number = 00, Payload = (00)(00)(FF)(FF)</p> <p>&lt; FDC0/TDS6 : Full duplex &gt;</p> <p>Pre-amble/Sync = Pattern P, Attribute = 00, Sequence number = 01, Payload = (00)(00)(FF)(FF)</p> <p>&lt; FDC0/TDS3 : Full duplex &gt;</p> <p>Pre-amble/Sync = Pattern P, Attribute = 00, Sequence number = 00, Payload = (00)(00)(FF)(FF)</p> <p>&lt; FDC0/TDS7 : Full duplex &gt;</p> <p>Pre-amble/Sync = Pattern P, Attribute = 00, Sequence number = 01, Payload = (00)(00)(FF)(FF)</p> <p>&lt; FDC0/TDS4 : Full duplex &gt;</p> <p>Pre-amble/Sync = Pattern P, Attribute = 00, Sequence number = 00, Payload = (00)(00)(FF)(FF)</p> <p>&lt; FDC0/TDS8 : Full duplex &gt;</p>	<p>4 →</p>	<p>&lt; FDC0 : LBT &gt;</p> <p>DUT should be able to detect the vacant TDS1 and TDS5 on FDC0.</p>

Test box with reference plate-electrode assembly	Step number and direction	Device under test (DUT)
Pre-amble/Sync = Pattern P, Attribute = 00, Sequence number = 01, Payload = (00)(00)(FF)(FF) (Test Box sends Full duplex P-PDUs on TDSs except TDS1 and TDS5 on FDC0)		
	5 ←	< FDC2/TDS1 : Association Request 1 > Pre-amble/Sync = Pattern P, Attribute = 00, Sequence number = 00, Payload = (20)(00)(E0)(FF) (Used FDC0, talker uses TDS1, listener uses TDS5, Full duplex)
< FDC2/TDS5 : Association Response 1 > Pre-amble/Sync = Pattern P, Attribute = 01, Sequence number = 01, Payload = (00)(00)(FF)(FF) < FDC2/TDS2 : Association Request 1 > Pre-amble/Sync = Pattern P, Attribute = 00, Sequence number = 00, Payload = (00)(00)(FF)(FF) < FDC2/TDS6 : Association Response 1 > Pre-amble/Sync = Pattern P, Attribute = 01, Sequence number = 01, Payload = (00)(00)(FF)(FF) < FDC2/TDS3 : Association Request 1 > Pre-amble/Sync = Pattern P, Attribute = 00, Sequence number = 00, Payload = (00)(00)(FF)(FF) < FDC2/TDS7 : Association Response 1 > Pre-amble/Sync = Pattern P, Attribute = 01, Sequence number = 01, Payload = (00)(00)(FF)(FF) < FDC2/TDS4 : Association Request 1 > Pre-amble/Sync = Pattern P, Attribute = 00, Sequence number = 00, Payload = (00)(00)(FF)(FF) < FDC2/TDS8 : Association Response 1 > Pre-amble/Sync = Pattern P, Attribute = 01, Sequence number = 01, Payload = (00)(00)(FF)(FF)	6 →	DUT should be able to receive Association Response 1.

Test box with reference plate-electrode assembly	Step number and direction	Device under test (DUT)
(Test Box sends Association Response 1 on FDC2/TDS5 from step 4)		
	7 ←	< FDC2/TDS1 : Association Request 2 > Pre-amble/Sync = Pattern P, Attribute = 01, Sequence number = 10, Payload = (00)(00)(FF)(FF)
<p>&lt; FDC2/TDS5 : Association Response 2 &gt; Pre-amble/Sync = Pattern P, Attribute = 00, Sequence number = 11, Payload = (20)(00)(DF)(FF)</p> <p>&lt; FDC2/TDS2 : Association Request 1 &gt; Pre-amble/Sync = Pattern P, Attribute = 00, Sequence number = 00, Payload = (00)(00)(FF)(FF)</p> <p>&lt; FDC2/TDS6 : Association Response 1 &gt; Pre-amble/Sync = Pattern P, Attribute = 01, Sequence number = 01, Payload = (00)(00)(FF)(FF)</p> <p>&lt; FDC2/TDS3 : Association Request 1 &gt; Pre-amble/Sync = Pattern P, Attribute = 00, Sequence number = 00, Payload = (00)(00)(FF)(FF)</p> <p>&lt; FDC2/TDS7 : Association Response 1 &gt; Pre-amble/Sync = Pattern P, Attribute = 01, Sequence number = 01, Payload = (00)(00)(FF)(FF)</p> <p>&lt; FDC2/TDS4 : Association Request 1 &gt; Pre-amble/Sync = Pattern P, Attribute = 00, Sequence number = 00, Payload = (00)(00)(FF)(FF)</p> <p>&lt; FDC2/TDS8 : Association Response 1 &gt; Pre-amble/Sync = Pattern P, Attribute = 01, Sequence number = 01, Payload = (00)(00)(FF)(FF)</p> <p>(Test Box sends Association Response 2 on FDC2/TDS5 from step 4)</p>	8 →	DUT should be able to receive Association Response 2.

Test box with reference plate-electrode assembly	Step number and direction	Device under test (DUT)
	<p>9</p> <p>←</p>	<p>&lt; FDC0/TDS1 : Full duplex &gt;</p> <p>Pre-amble/Sync = Pattern P, Attribute = 10, Sequence number = 00, Payload = (0A)(00)(55)(AA)</p> <p>(DUT sends the first P-DU segment)</p>
<p>&lt; FDC0/TDS5 : Full duplex &gt;</p> <p>Pre-amble/Sync = Pattern P, Attribute = 10, Sequence number = 01, Payload = (0A)(00)(55)(AA)</p> <p>&lt; FDC0/TDS2 : Full duplex &gt;</p> <p>Pre-amble/Sync = Pattern P, Attribute = 00, Sequence number = 00, Payload = (00)(00)(FF)(FF)</p> <p>&lt; FDC0/TDS6 : Full duplex &gt;</p> <p>Pre-amble/Sync = Pattern P, Attribute = 00, Sequence number = 01, Payload = (00)(00)(FF)(FF)</p> <p>&lt; FDC0/TDS3 : Full duplex &gt;</p> <p>Pre-amble/Sync = Pattern P, Attribute = 00, Sequence number = 00, Payload = (00)(00)(FF)(FF)</p> <p>&lt; FDC0/TDS7 : Full duplex &gt;</p> <p>Pre-amble/Sync = Pattern P, Attribute = 00, Sequence number = 01, Payload = (00)(00)(FF)(FF)</p> <p>&lt; FDC0/TDS4 : Full duplex &gt;</p> <p>Pre-amble/Sync = Pattern P, Attribute = 00, Sequence number = 00, Payload = (00)(00)(FF)(FF)</p> <p>&lt; FDC0/TDS8 : Full duplex &gt;</p> <p>Pre-amble/Sync = Pattern P, Attribute = 00, Sequence number = 01, Payload = (00)(00)(FF)(FF)</p> <p>(Test Box sends Full duplex P-PDUs on TDS5 on FDC2 from step 4)</p>	<p>10</p> <p>→</p>	<p>DUT should be able to receive Full duplex P-DPU on FDC0/TDS5.</p>



Test box with reference plate-electrode assembly	Step number and direction	Device under test (DUT)
	11 ←	< FDC0/TDS1 Full duplex > Pre-amble/Sync = Pattern P, Attribute = 11, Sequence number = 10, Payload = (00)(FF)(C3)(E7) (DUT sends the between P-DU segment)
< FDC0/TDS5 : Full duplex > Pre-amble/Sync = Pattern P, Attribute = 11, Sequence number = 11, Payload = (00)(FF)(C3)(E7) < FDC0/TDS2 : Full duplex > Pre-amble/Sync = Pattern P, Attribute = 00, Sequence number = 00, Payload = (00)(00)(FF)(FF) < FDC0/TDS6 : Full duplex > Pre-amble/Sync = Pattern P, Attribute = 00, Sequence number = 01, Payload = (00)(00)(FF)(FF) < FDC0/TDS3 : Full duplex > Pre-amble/Sync = Pattern P, Attribute = 00, Sequence number = 00, Payload = (00)(00)(FF)(FF) < FDC0/TDS7 : Full duplex > Pre-amble/Sync = Pattern P, Attribute = 00, Sequence number = 01, Payload = (00)(00)(FF)(FF) < FDC0/TDS4 : Full duplex > Pre-amble/Sync = Pattern P, Attribute = 00, Sequence number = 00, Payload = (00)(00)(FF)(FF) < FDC0/TDS8 : Full duplex > Pre-amble/Sync = Pattern P, Attribute = 00, Sequence number = 01, Payload = (00)(00)(FF)(FF) (Test Box sends Full duplex P-PDUs on TDS5 on FDC2 from step 4)	12 →	DUT should be able to receive Full duplex P-DPU on FDC0/TDS5.

Test box with reference plate-electrode assembly	Step number and direction	Device under test (DUT)
	13 ←	< FDC0/TDS1 : Full duplex > Pre-amble/Sync = Pattern P, Attribute = 01, Sequence number = 00, Payload = (96)(42)(B0)(4A) (DUT sends the last P-DU segment)
< FDC0/TDS5 : Full duplex > Pre-amble/Sync = Pattern P, Attribute = 01, Sequence number = 01, Payload = (96)(42)(B0)(4A) < FDC0/TDS2 : Full duplex > Pre-amble/Sync = Pattern P, Attribute = 00, Sequence number = 00, Payload = (00)(00)(FF)(FF) < FDC0/TDS6 : Full duplex > Pre-amble/Sync = Pattern P, Attribute = 00, Sequence number = 01, Payload = (00)(00)(FF)(FF) < FDC0/TDS3 : Full duplex > Pre-amble/Sync = Pattern P, Attribute = 00, Sequence number = 00, Payload = (00)(00)(FF)(FF) < FDC0/TDS7 : Full duplex > Pre-amble/Sync = Pattern P, Attribute = 00, Sequence number = 01, Payload = (00)(00)(FF)(FF) < FDC0/TDS4 : Full duplex > Pre-amble/Sync = Pattern P, Attribute = 00, Sequence number = 00, Payload = (00)(00)(FF)(FF) < FDC0/TDS8 : Full duplex > Pre-amble/Sync = Pattern P, Attribute = 00, Sequence number = 01, Payload = (00)(00)(FF)(FF) (Test Box sends Full duplex P-PDU on TDS5 on FDC2 from step 4)	14 →	DUT should be able to receive Full duplex P-DPU on FDC0/TDS5.

**Table A.7 — Test scenario 6**

Test box with reference plate-electrode assembly	Step number and direction	Device under test (DUT)
<p>&lt; FDC2/TDS1 : Association Request 1 &gt;            Pre-amble/Sync = Pattern P, Attribute = 00,            Sequence number = 00, Payload = (00)(00)(FF)(FF)</p> <p>&lt; FDC2/TDS5 : Association Response 1 &gt;            Pre-amble/Sync = Pattern P, Attribute = 01,            Sequence number = 01, Payload = (00)(00)(FF)(FF)</p> <p>&lt; FDC2/TDS2 : Association Request 1 &gt;            Pre-amble/Sync = Pattern P, Attribute = 00,            Sequence number = 00, Payload = (00)(00)(FF)(FF)</p> <p>&lt; FDC2/TDS6 : Association Response 1 &gt;            Pre-amble/Sync = Pattern P, Attribute = 01,            Sequence number = 01, Payload = (00)(00)(FF)(FF)</p> <p>&lt; FDC2/TDS3 : Association Request 1 &gt;            Pre-amble/Sync = Pattern P, Attribute = 00,            Sequence number = 00, Payload = (00)(00)(FF)(FF)</p> <p>&lt; FDC2/TDS7 : Association Response 1 &gt;            Pre-amble/Sync = Pattern P, Attribute = 01,            Sequence number = 01, Payload = (00)(00)(FF)(FF)</p> <p>&lt; FDC2/TDS4 : Association Request 1 &gt;            Pre-amble/Sync = Pattern P, Attribute = 00,            Sequence number = 00, Payload = (00)(00)(FF)(FF)</p> <p>&lt; FDC2/TDS8 : Association Response 1 &gt;            Pre-amble/Sync = Pattern P, Attribute = 01,            Sequence number = 01, Payload = (00)(00)(FF)(FF)</p> <p>(Test Box sends Association Request 1 or Association Response 1 on all TDSs on FDC2)</p>	<p>1 →</p>	<p>&lt; FDC2 : LBT &gt;            DUT should be able to detect all occupied TDSs on FDC2.</p>

Test box with reference plate-electrode assembly	Step number and direction	Device under test (DUT)
<p>&lt; FDC0/TDS1 : Broadcast &gt;            Pre-amble/Sync = Pattern P, Attribute = 00,            Sequence number = 00, Payload = (00)(00)(FF)(FF)</p> <p>&lt; FDC0/TDS2 : Broadcast &gt;            Pre-amble/Sync = Pattern P, Attribute = 00,            Sequence number = 00, Payload = (00)(00)(FF)(FF)</p> <p>&lt; FDC0/TDS3 : Broadcast &gt;            Pre-amble/Sync = Pattern P, Attribute = 00,            Sequence number = 00, Payload = (00)(00)(FF)(FF)</p> <p>&lt; FDC0/TDS4 : Broadcast &gt;            Pre-amble/Sync = Pattern P, Attribute = 00,            Sequence number = 00, Payload = (00)(00)(FF)(FF)</p> <p>&lt; FDC0/TDS5 : Broadcast &gt;            Pre-amble/Sync = Pattern P, Attribute = 00,            Sequence number = 01, Payload = (00)(00)(FF)(FF)</p> <p>&lt; FDC0/TDS6 : Broadcast &gt;            Pre-amble/Sync = Pattern P, Attribute = 00,            Sequence number = 01, Payload = (00)(00)(FF)(FF)</p> <p>&lt; FDC0/TDS7 : Broadcast &gt;            Pre-amble/Sync = Pattern P, Attribute = 00,            Sequence number = 01, Payload = (00)(00)(FF)(FF)</p> <p>&lt; FDC0/TDS8 : Broadcast &gt;            Pre-amble/Sync = Pattern P, Attribute = 00,            Sequence number = 01, Payload = (00)(00)(FF)(FF)</p> <p>(Test Box sends : Broadcast P-PDUs on all TDSs on FDC0)</p>	<p>2 →</p>	<p>&lt; FDC0 : LBT &gt;            DUT should be able to detect all occupied TDSs on FDC0.</p>
<p>&lt; FDC2/TDS2 : Association Request 1 &gt;            Pre-amble/Sync = Pattern P, Attribute = 00,            Sequence number = 00, Payload = (00)(00)(FF)(FF)</p> <p>&lt; FDC2/TDS6 : Association Response 1 &gt;</p>	<p>3 →</p>	<p>&lt; FDC2 : LBT &gt;            DUT should be able to detect the vacant TDS1 and TDS5 on FDC2.</p>

Test box with reference plate-electrode assembly	Step number and direction	Device under test (DUT)
<p>Pre-amble/Sync = Pattern P, Attribute = 01, Sequence number = 01, Payload = (00)(00)(FF)(FF) &lt; FDC2/TDS3 : Association Request 1 &gt; Pre-amble/Sync = Pattern P, Attribute = 00, Sequence number = 00, Payload = (00)(00)(FF)(FF) &lt; FDC2/TDS7 : Association Response 1 &gt; Pre-amble/Sync = Pattern P, Attribute = 01, Sequence number = 01, Payload = (00)(00)(FF)(FF) &lt; FDC2/TDS4 : Association Request 1 &gt; Pre-amble/Sync = Pattern P, Attribute = 00, Sequence number = 00, Payload = (00)(00)(FF)(FF) &lt; FDC2/TDS8 : Association Response 1 &gt; Pre-amble/Sync = Pattern P, Attribute = 01, Sequence number = 01, Payload = (00)(00)(FF)(FF) (Test Box sends Association Request 1 or Association Response 1 on TDSs except TDS1 and TDS5 on FDC2)</p>		
<p>&lt; FDC0/TDS2 : Broadcast &gt; Pre-amble/Sync = Pattern P, Attribute = 00, Sequence number = 00, Payload = (00)(00)(FF)(FF) &lt; FDC0/TDS3 : Broadcast &gt; Pre-amble/Sync = Pattern P, Attribute = 00, Sequence number = 00, Payload = (00)(00)(FF)(FF) &lt; FDC0/TDS4 : Broadcast &gt; Pre-amble/Sync = Pattern P, Attribute = 00, Sequence number = 00, Payload = (00)(00)(FF)(FF) &lt; FDC0/TDS5 : Broadcast &gt; Pre-amble/Sync = Pattern P, Attribute = 00, Sequence number = 01, Payload = (00)(00)(FF)(FF) &lt; FDC0/TDS6 : Broadcast &gt;</p>	<p>4 →</p>	<p>&lt; FDC0 : LBT &gt; DUT should be able to detect the vacant TDS1 on FDC0.</p>

Test box with reference plate-electrode assembly	Step number and direction	Device under test (DUT)
<p>Pre-amble/Sync = Pattern P, Attribute = 00, Sequence number = 01, Payload = (00)(00)(FF)(FF) &lt; FDC0/TDS7 : Broadcast &gt;</p> <p>Pre-amble/Sync = Pattern P, Attribute = 00, Sequence number = 01, Payload = (00)(00)(FF)(FF) &lt; FDC0/TDS8 : Broadcast &gt;</p> <p>Pre-amble/Sync = Pattern P, Attribute = 00, Sequence number = 01, Payload = (00)(00)(FF)(FF)</p> <p>(Test Box sends : Broadcast P-PDU except TDS1 on FDC0)</p>		
	<p>5 ←</p>	<p>&lt; FDC2/TDS1 : Association Request 1 &gt; Pre-amble/Sync = Pattern P, Attribute = 00, Sequence number = 00, Payload = (00)(02)(FF)(FD)  (Used FDC0, talker uses TDS1, listener uses TDS5, Full duplex)</p>
<p>&lt; FDC2/TDS5 : Association Response 1 &gt; Pre-amble/Sync = Pattern P, Attribute = 01, Sequence number = 01, Payload = (00)(00)(FF)(FF) &lt; FDC2/TDS2 : Association Request 1 &gt; Pre-amble/Sync = Pattern P, Attribute = 00, Sequence number = 00, Payload = (00)(00)(FF)(FF) &lt; FDC2/TDS6 : Association Response 1 &gt; Pre-amble/Sync = Pattern P, Attribute = 01, Sequence number = 01, Payload = (00)(00)(FF)(FF) &lt; FDC2/TDS3 : Association Request 1 &gt; Pre-amble/Sync = Pattern P, Attribute = 00, Sequence number = 00, Payload = (00)(00)(FF)(FF) &lt; FDC2/TDS7 : Association Response 1 &gt; Pre-amble/Sync = Pattern P, Attribute = 01, Sequence number = 01, Payload = (00)(00)(FF)(FF)</p>	<p>6 →</p>	<p>DUT should be able to receive Association Response 1.</p>

Test box with reference plate-electrode assembly	Step number and direction	Device under test (DUT)
<p>&lt; FDC2/TDS4 : Association Request 1 &gt;            Pre-amble/Sync = Pattern P, Attribute = 00,            Sequence number = 00, Payload = (00)(00)(FF)(FF)</p> <p>&lt; FDC2/TDS8 : Association Response 1 &gt;            Pre-amble/Sync = Pattern P, Attribute = 01,            Sequence number = 01, Payload = (00)(00)(FF)(FF)</p> <p>(Test Box sends Association Response 1 on FDC2/TDS5 from step 4)</p>		
	7 ←	<p>&lt; FDC2/TDS1 : Association Request 2 &gt;            Pre-amble/Sync = Pattern P, Attribute = 01,            Sequence number = 10, Payload = (00)(00)(FF)(FF)</p>
<p>&lt; FDC2/TDS5 : Association Response 2 &gt;            Pre-amble/Sync = Pattern P, Attribute = 00,            Sequence number = 11, Payload = (00)(02)(FF)(FD)</p> <p>&lt; FDC2/TDS2 : Association Request 1 &gt;            Pre-amble/Sync = Pattern P, Attribute = 00,            Sequence number = 00, Payload = (00)(00)(FF)(FF)</p> <p>&lt; FDC2/TDS6 : Association Response 1 &gt;            Pre-amble/Sync = Pattern P, Attribute = 01,            Sequence number = 01, Payload = (00)(00)(FF)(FF)</p> <p>&lt; FDC2/TDS3 : Association Request 1 &gt;            Pre-amble/Sync = Pattern P, Attribute = 00,            Sequence number = 00, Payload = (00)(00)(FF)(FF)</p> <p>&lt; FDC2/TDS7 : Association Response 1 &gt;            Pre-amble/Sync = Pattern P, Attribute = 01,            Sequence number = 01, Payload = (00)(00)(FF)(FF)</p> <p>&lt; FDC2/TDS4 : Association Request 1 &gt;            Pre-amble/Sync = Pattern P, Attribute = 00,            Sequence number = 00, Payload = (00)(00)(FF)(FF)</p> <p>&lt; FDC2/TDS8 : Association Response 1 &gt;</p>	8 →	<p>DUT should be able to receive Association Response 2.</p>

Test box with reference plate-electrode assembly	Step number and direction	Device under test (DUT)
Pre-amble/Sync = Pattern P, Attribute = 01, Sequence number = 01, Payload = (00)(00)(FF)(FF) (Test Box sends Association Response 2 on FDC2/TDS5 from step 4)		
(Test Box sends same P-PDUs and checks to receive the P-PDU from DUT with iteration count)	9 ←	< FDC0/TDS1 : Broadcast > Pre-amble/Sync = Pattern P, Attribute = 10, Sequence number = 00, Payload = (0A)(00)(55)(AA) — Check iteration count function (DUT sends the first P-DU segment iteration count times)
(Test Box sends same P-PDUs and checks to receive the P-PDU from DUT with iteration count)	10 ←	< FDC0/TDS1 : Broadcast > Pre-amble/Sync = Pattern P, Attribute = 11, Sequence number = 01, Payload = (00)(FF)(C3)(E7) — Check iteration count function (DUT sends the between P-DU segment iteration count times)
(Test Box sends same P-PDUs and checks to receive the P-PDU from DUT with iteration count)	11 ←	< FDC0/TDS1 : Broadcast > Pre-amble/Sync = Pattern P, Attribute = 01, Sequence number = 10, Payload = (96)(42)(B0)(4A) — Check iteration count function (DUT sends the last P-DU segment iteration count times)



Table A.8 — Test scenario 7

Test box with reference plate-electrode assembly	Step number and direction	Device under test (DUT)
<p>&lt; FDC1/TDS2 : Full duplex &gt;            Pre-amble/Sync = Pattern P, Attribute = 00,            Sequence number = 00, Payload = (00)(00)(FF)(FF)</p> <p>&lt; FDC1/TDS6 : Full duplex &gt;            Pre-amble/Sync = Pattern P, Attribute = 00,            Sequence number = 01, Payload = (00)(00)(FF)(FF)</p> <p>&lt; FDC1/TDS3 : Full duplex &gt;            Pre-amble/Sync = Pattern P, Attribute = 00,            Sequence number = 00, Payload = (00)(00)(FF)(FF)</p> <p>&lt; FDC1/TDS7 : Full duplex &gt;            Pre-amble/Sync = Pattern P, Attribute = 00,            Sequence number = 01, Payload = (00)(00)(FF)(FF)</p> <p>&lt; FDC1/TDS4 : Full duplex &gt;            Pre-amble/Sync = Pattern P, Attribute = 00,            Sequence number = 00, Payload = (00)(00)(FF)(FF)</p> <p>&lt; FDC1/TDS8 : Full duplex &gt;            Pre-amble/Sync = Pattern P, Attribute = 00,            Sequence number = 01, Payload = (00)(00)(FF)(FF)</p> <p>(Test Box sends Full duplex P-PDUs on TDSs except TDS1 and TDS5 on FDC0)</p>	<p>1 →</p>	
	<p>2 ←</p>	<p>&lt; FDC1/TDS1 : Full duplex &gt;            Pre-amble/Sync = Pattern P, Attribute = 10,            Sequence number = 00, Payload = (0A)(00)(55)(AA)            (DUT sends the first P-DU segment)</p>
<p>&lt; FDC1/TDS5 : Full duplex &gt;            Pre-amble/Sync = Pattern P, Attribute = 10,            Sequence number = 01, Payload = (0A)(00)(55)(AA)</p> <p>&lt; FDC1/TDS2 : Full duplex &gt;            Pre-amble/Sync = Pattern P, Attribute = 00,</p>	<p>3 →</p>	<p>DUT should be able to receive Full duplex P-DPU on FDC1/TDS5.</p>

Test box with reference plate-electrode assembly	Step number and direction	Device under test (DUT)
<p>Sequence number = 00, Payload = (00)(00)(FF)(FF)</p> <p>&lt; FDC1/TDS6 : Full duplex &gt;</p> <p>Pre-amble/Sync = Pattern P, Attribute = 00,</p> <p>Sequence number = 01, Payload = (00)(00)(FF)(FF)</p> <p>&lt; FDC1/TDS3 : Full duplex &gt;</p> <p>Pre-amble/Sync = Pattern P, Attribute = 00,</p> <p>Sequence number = 00, Payload = (00)(00)(FF)(FF)</p> <p>&lt; FDC1/TDS7 : Full duplex &gt;</p> <p>Pre-amble/Sync = Pattern P, Attribute = 00,</p> <p>Sequence number = 01, Payload = (00)(00)(FF)(FF)</p> <p>&lt; FDC1/TDS4 : Full duplex &gt;</p> <p>Pre-amble/Sync = Pattern P, Attribute = 00,</p> <p>Sequence number = 00, Payload = (00)(00)(FF)(FF)</p> <p>&lt; FDC1/TDS8 : Full duplex &gt;</p> <p>Pre-amble/Sync = Pattern P, Attribute = 00,</p> <p>Sequence number = 01, Payload = (00)(00)(FF)(FF)</p> <p>(Test Box sends Full duplex P-PDU on TDS5 on FDC2 from step 4)</p>		
	<p>4</p> <p>←</p>	<p>&lt; FDC1/TDS1 Full duplex &gt;</p> <p>Pre-amble/Sync = Pattern P, Attribute = 11,</p> <p>Sequence number = 10, Payload = (00)(FF)(C3)(E7)</p> <p>(DUT sends the between P-DU segment)</p>
<p>&lt; FDC1/TDS5 : Full duplex &gt;</p> <p>Pre-amble/Sync = Pattern P, Attribute = 11,</p> <p>Sequence number = 11, Payload = (00)(FF)(C3)(E7)</p> <p>&lt; FDC1/TDS2 : Full duplex &gt;</p> <p>Pre-amble/Sync = Pattern P, Attribute = 00,</p> <p>Sequence number = 00, Payload = (00)(00)(FF)(FF)</p> <p>&lt; FDC1/TDS6 : Full duplex &gt;</p> <p>Pre-amble/Sync = Pattern P, Attribute = 00,</p>	<p>5</p> <p>→</p>	<p>DUT should be able to receive Full duplex P-DPU on FDC1/TDS5.</p>

Test box with reference plate-electrode assembly	Step number and direction	Device under test (DUT)
<p>Sequence number = 01, Payload = (00)(00)(FF)(FF)</p> <p>&lt; FDC1/TDS3 : Full duplex &gt;</p> <p>Pre-amble/Sync = Pattern P, Attribute = 00,</p> <p>Sequence number = 00, Payload = (00)(00)(FF)(FF)</p> <p>&lt; FDC1/TDS7 : Full duplex &gt;</p> <p>Pre-amble/Sync = Pattern P, Attribute = 00,</p> <p>Sequence number = 01, Payload = (00)(00)(FF)(FF)</p> <p>&lt; FDC1/TDS4 : Full duplex &gt;</p> <p>Pre-amble/Sync = Pattern P, Attribute = 00,</p> <p>Sequence number = 00, Payload = (00)(00)(FF)(FF)</p> <p>&lt; FDC1/TDS8 : Full duplex &gt;</p> <p>Pre-amble/Sync = Pattern P, Attribute = 00,</p> <p>Sequence number = 01, Payload = (00)(00)(FF)(FF)</p> <p>(Test Box sends Full duplex P-PDU on TDS5 on FDC2 from step 4)</p>		
	<p>6</p> <p>←</p>	<p>&lt; FDC1/TDS1 : Full duplex &gt;</p> <p>Pre-amble/Sync = Pattern P, Attribute = 01,</p> <p>Sequence number = 00, Payload = (96)(42)(B0)(4A)</p> <p>(DUT sends the last P-DU segment)</p>
<p>&lt; FDC1/TDS5 : Full duplex &gt;</p> <p>Pre-amble/Sync = Pattern P, Attribute = 01,</p> <p>Sequence number = 01, Payload = (96)(42)(B0)(4A)</p> <p>&lt; FDC1/TDS2 : Full duplex &gt;</p> <p>Pre-amble/Sync = Pattern P, Attribute = 00,</p> <p>Sequence number = 00, Payload = (00)(00)(FF)(FF)</p> <p>&lt; FDC1/TDS6 : Full duplex &gt;</p> <p>Pre-amble/Sync = Pattern P, Attribute = 00,</p> <p>Sequence number = 01, Payload = (00)(00)(FF)(FF)</p> <p>&lt; FDC1/TDS3 : Full duplex &gt;</p> <p>Pre-amble/Sync = Pattern P, Attribute = 00,</p>	<p>7</p> <p>→</p>	<p>DUT should be able to receive Full duplex P-DPU on FDC1/TDS5.</p>

Test box with reference plate-electrode assembly	Step number and direction	Device under test (DUT)
<p>Sequence number = 00, Payload = (00)(00)(FF)(FF)</p> <p>&lt; FDC1/TDS7 : Full duplex &gt;</p> <p>Pre-amble/Sync = Pattern P, Attribute = 00,</p> <p>Sequence number = 01, Payload = (00)(00)(FF)(FF)</p> <p>&lt; FDC1/TDS4 : Full duplex &gt;</p> <p>Pre-amble/Sync = Pattern P, Attribute = 00,</p> <p>Sequence number = 00, Payload = (00)(00)(FF)(FF)</p> <p>&lt; FDC1/TDS8 : Full duplex &gt;</p> <p>Pre-amble/Sync = Pattern P, Attribute = 00,</p> <p>Sequence number = 01, Payload = (00)(00)(FF)(FF)</p> <p>(Test Box sends Full duplex P-PDU on TDS5 on FDC2 from step 4)</p>		

**Table A.9 — Test scenario 8**

Test box with reference plate-electrode assembly	Step number and direction	Device under test (DUT)
(DUT sends same P-PDUs and Test Box checks to receive the P-PDU from DUT with iteration count)	1 ←	<p>&lt; FDC1/TDS1 : Broadcast &gt;</p> <p>Pre-amble/Sync = Pattern P, Attribute = 10, Sequence number = 00, Payload = (0A)(00)(55)(AA)</p> <p>— Check iteration count function</p> <p>(DUT sends the first P-DU segment iteration count times)</p>
(DUT sends same P-PDUs and Test Box checks to receive the P-PDU from DUT with iteration count)	2 ←	<p>&lt; FDC1/TDS1 : Broadcast &gt;</p> <p>Pre-amble/Sync = Pattern P, Attribute = 11, Sequence number = 01, Payload = (00)(FF)(C3)(E7)</p> <p>— Check iteration count function</p> <p>(DUT sends the between P-DU segment iteration count times)</p>
(DUT sends same P-PDUs and Test Box checks to receive the P-PDU from DUT with iteration count)	3 ←	<p>&lt; FDC1/TDS1 : Broadcast &gt;</p> <p>Pre-amble/Sync = Pattern P, Attribute = 01, Sequence number = 10, Payload = (96)(42)(B0)(4A)</p> <p>— Check iteration count function</p> <p>(DUT sends the last P-DU segment iteration count times)</p>



## **Annex B** **(informative)**

### **Guidance for implementation of this document**

This document has enough flexibility to adapt to various industrial applications by choosing FDC2 for P-PDUs of association procedure and other FDCs for null and data P-PDUs. ISO/IEC TR 22512<sup>[1]</sup> shows an implementation of this document for small size and low power devices. This implementation enables the choice of one FDC for all P-PDUs by utilizing state machines on both a talker and a listener where the state, combined with attribution settings defined in Table 2, provides 3-bit-entropy to distinguish the six types of P-PDUs. This implementation needs to support the selected FDC only and reduces hardware size and cost.





## Bibliography (if any)

- [1] ISO/IEC/TR 22512, *Information technology — Telecommunications and information exchange between systems — Guidelines for the implementation of ISO/IEC 17982:2012*

