

# Standard ECMA-423

1<sup>st</sup> Edition / June 2023

## **Holographic Data Storage Disk (HDSD) – Capacity: 1 Tbyte per disk**

# Standard



**COPYRIGHT PROTECTED DOCUMENT**

## Contents

Page

|               |  |           |
|---------------|--|-----------|
| <b>1</b>      | <b>Scope .....</b>   | <b>1</b>  |
| <b>2</b>      | <b>Conformance.....</b>  | <b>1</b>  |
| <b>2.1</b>    | <b>Holographic disk.....</b>   | <b>1</b>  |
| <b>2.2</b>    | <b>Recoding system .....</b>   | <b>1</b>  |
| <b>2.3</b>    | <b>Reading system .....</b>  | <b>1</b>  |
| <b>3</b>      | <b>Normative references .....</b>  | <b>1</b>  |
| <b>4</b>      | <b>Terms and definitions.....</b>  | <b>2</b>  |
| <b>5</b>      | <b>Abbreviated terms .....</b>   | <b>4</b>  |
| <b>6</b>      | <b>Conventions and notation .....</b>  | <b>4</b>  |
| <b>7</b>      | <b>General description of hologram disk and its data recording and reading method .....</b>                  | <b>5</b>  |
| <b>8</b>      | <b>General requirement.....</b>  | <b>5</b>  |
| <b>8.1</b>    | <b>General.....</b>  | <b>5</b>  |
| <b>8.2</b>    | <b>Environment .....</b>   | <b>5</b>  |
| <b>8.2.1</b>  | <b>General.....</b>  | <b>5</b>  |
| <b>8.2.2</b>  | <b>Operating environment .....</b>   | <b>5</b>  |
| <b>8.2.3</b>  | <b>Storage environment.....</b>  | <b>6</b>  |
| <b>8.2.4</b>  | <b>Transportation.....</b>   | <b>6</b>  |
| <b>8.2.5</b>  | <b>Temperature shock.....</b>  | <b>6</b>  |
| <b>8.3</b>    | <b>Safety requirement .....</b>  | <b>6</b>  |
| <b>8.4</b>    | <b>Flammability .....</b>  | <b>6</b>  |
| <b>9</b>      | <b>Reference drive .....</b>   | <b>7</b>  |
| <b>9.1</b>    | <b>General.....</b>  | <b>7</b>  |
| <b>9.2</b>    | <b>Optical system .....</b>  | <b>7</b>  |
| <b>9.3</b>    | <b>Hologram recording and reading channel .....</b>  | <b>9</b>  |
| <b>9.3.1</b>  | <b>General.....</b>  | <b>9</b>  |
| <b>9.3.2</b>  | <b>Signal beam.....</b>  | <b>9</b>  |
| <b>9.3.3</b>  | <b>Reference beam and reading beam .....</b>   | <b>9</b>  |
| <b>9.3.4</b>  | <b>Objective lens.....</b>   | <b>10</b> |
| <b>9.3.5</b>  | <b>Digital Mirror Device (DMD) .....</b>   | <b>10</b> |
| <b>9.3.6</b>  | <b>Hologram reading channel .....</b>  | <b>11</b> |
| <b>9.4</b>    | <b>Tracking and focusing signal detection channel .....</b>  | <b>11</b> |
| <b>9.4.1</b>  | <b>General.....</b>  | <b>11</b> |
| <b>9.4.2</b>  | <b>Tracking, focusing signal and address and SDI data .....</b>  | <b>11</b> |
| <b>9.4.3</b>  | <b>Tracking and focusing beam .....</b>  | <b>11</b> |
| <b>9.5</b>    | <b>Conditions for measuring the operational signals.....</b>   | <b>12</b> |
| <b>9.5.1</b>  | <b>Axial and radial deviation of tracking and focusing beam .....</b>  | <b>12</b> |
| <b>9.5.2</b>  | <b>Relative positions of the signal beam and the tracking and focusing beams during data recording .....</b> | <b>12</b> |
| <b>9.5.3</b>  | <b>Relative positions of the reading beam and the tracking and focusing beams during data reading .....</b>  | <b>12</b> |
| <b>9.6</b>    | <b>Pre-cure and post-cure.....</b>   | <b>12</b> |
| <b>10</b>     | <b>Dimension, mechanical, optical and physical characteristics of disk.....</b>                              | <b>13</b> |
| <b>10.1</b>   | <b>General.....</b>  | <b>13</b> |
| <b>10.2</b>   | <b>General configuration of the disk .....</b>   | <b>13</b> |
| <b>10.2.1</b> | <b>Configuration of the disk .....</b>   | <b>13</b> |
| <b>10.2.2</b> | <b>Track arrangement on a disk.....</b>  | <b>13</b> |
| <b>10.3</b>   | <b>Reference axis and reference plane of the disk .....</b>  | <b>14</b> |

|        |  |    |
|--------|--|----|
| 10.4   | Dimensions of the disk.....                    | 15 |
| 10.5   | Clamping zone.....                             | 15 |
| 10.6   | Mechanical characteristics .....               | 16 |
| 10.6.1 | Material.....                                  | 16 |
| 10.6.2 | Mass .....                                     | 16 |
| 10.6.3 | Axial deflection.....                          | 16 |
| 10.6.4 | Radial runout .....                            | 16 |
| 10.6.5 | Angular deviation .....                        | 16 |
| 10.7   | Optical characteristics.....                   | 16 |
| 10.7.1 | Substrate.....                                 | 16 |
| 10.7.2 | Reflective layer .....                         | 17 |
| 10.7.3 | Recording layer .....                          | 17 |
| 11     | Interface between cartridge and drive .....    | 17 |
| 11.1   | General .....                                  | 17 |
| 11.2   | Clamping method .....                          | 17 |
| 11.3   | Tapered cone for disk clamping.....            | 17 |
| 11.4   | Clamping force .....                           | 17 |
| 12     | Track format .....                             | 17 |
| 12.1   | General.....                                   | 17 |
| 12.2   | Sector format .....                            | 18 |
| 12.2.1 | Sector .....                                   | 18 |
| 12.2.2 | Sector layout .....                            | 18 |
| 12.2.3 | Header .....                                   | 18 |
| 12.2.4 | Sync field .....                               | 22 |
| 12.2.5 | Timing data mark field .....                   | 22 |
| 12.2.6 | Land field .....                               | 22 |
| 12.3   | Specific Disk Information (SDI).....           | 22 |
| 12.3.1 | General .....                                  | 22 |
| 12.3.2 | SDI bytes encoding.....                        | 22 |
| 12.4   | Channel bits radial alignment.....             | 23 |
| 13     | Data information format .....                  | 23 |
| 13.1   | General.....                                   | 23 |
| 13.2   | Data page holograms layout.....                | 23 |
| 13.2.1 | Hologram layout format.....                    | 23 |
| 13.2.2 | Data page holograms layout within tracks.....  | 24 |
| 13.2.3 | Radial data page hologram pitch .....          | 24 |
| 13.2.4 | Tangential data page hologram pitch .....      | 24 |
| 13.3   | Data page encoding .....                       | 24 |
| 13.3.1 | Encoding process .....                         | 24 |
| 13.3.2 | Page header .....                              | 26 |
| 13.3.3 | Page footer.....                               | 26 |
| 13.3.4 | Page number .....                              | 26 |
| 13.4   | ECC.....                                       | 27 |
| 13.4.1 | General .....                                  | 27 |
| 13.4.2 | Inter-Page ECC .....                           | 27 |
| 13.4.3 | Intra-Page ECC .....                           | 27 |
| 13.4.4 | Interleaving .....                             | 27 |
| 13.5   | Data to image conversion .....                 | 27 |
| 13.5.1 | General .....                                  | 27 |
| 13.5.2 | Recording page format.....                     | 27 |
| 13.5.3 | Symbol .....                                   | 28 |
| 13.5.4 | Sync pattern .....                             | 29 |
| 13.5.5 | Subpage and page sync pattern.....             | 29 |
| 13.5.6 | User data capacity of one page .....           | 30 |
| 14     | Formatted zone .....                           | 30 |
| 14.1   | General .....                                  | 30 |
| 14.2   | Structure and usage of the formatted zone..... | 30 |

|         |  |    |
|---------|--|----|
| 14.2.1  | General.....   | 30 |
| 14.2.2  | Zone 0 .....   | 30 |
| 14.2.3  | Zones 1 - User data zone .....   | 30 |
| 14.2.4  | Zone 2 - Lead-out zone.....  | 31 |
| 15      | Finalizing of disk.....  | 31 |
| 16      | Test condition for the signals from the tracking and focusing signal detection channel .....       | 31 |
| 16.1    | General.....   | 31 |
| 16.2    | Environment .....  | 31 |
| 16.3    | Test drive .....   | 31 |
| 16.3.1  | General.....   | 31 |
| 16.3.2  | Optics and mechanics.....  | 31 |
| 16.3.3  | Tracking requirements .....  | 31 |
| 16.4    | Signals from 4 split photodetector .....   | 32 |
| 17      | Requirement of the signals from tracking & focusing signal detection channel.....                  | 33 |
| 17.1    | General.....   | 33 |
| 17.2    | Reflectivity .....   | 33 |
| 17.3    | Normalized Push Pull signal.....   | 33 |
| 17.4    | Modulation .....   | 33 |
| 17.5    | Resolution .....   | 33 |
| 17.6    | 5T top signal fluctuation .....  | 33 |
| 17.7    | Jitter .....   | 34 |
| 17.8    | Phase depth.....   | 34 |
| 18      | Data recording test condition and recording characteristics requirement .....                      | 34 |
| 18.1    | General.....   | 34 |
| 18.2    | Environment .....  | 34 |
| 18.3    | Test drive .....   | 34 |
| 18.3.1  | General.....   | 34 |
| 18.3.2  | Optics and mechanics.....  | 34 |
| 18.3.3  | Data recording pulses energy .....   | 34 |
| 18.3.4  | Data reading pulses energy .....   | 34 |
| 18.3.5  | Tracking requirements .....  | 34 |
| 18.3.6  | Relative position of the focus of the data recording beam and the tracking and focusing beam.....  | 35 |
| 18.4    | Recording conditions .....   | 35 |
| 18.4.1  | Recording pulse energy .....   | 35 |
| 18.4.2  | Recording pulse energy determination .....   | 35 |
| 18.5    | Recording characteristics requirement.....   | 35 |
| 19      | Recorded user data reading test conditions and requirement .....                                   | 35 |
| 19.1    | General.....   | 35 |
| 19.2    | Environment .....  | 35 |
| 19.3    | Test drive .....   | 35 |
| 19.3.1  | General.....   | 35 |
| 19.3.2  | Optics and mechanics.....  | 35 |
| 19.3.3  | Data reading pulses energy .....   | 36 |
| 19.3.4  | Tracking requirements .....  | 36 |
| 19.3.5  | Relative positioning of the focus of the data reading beam and the tracking and focusing beam..... | 36 |
| 19.4    | Data page quality minimum requirement .....  | 36 |
| 20      | Data interchange requirements.....   | 36 |
| 20.1    | General.....   | 36 |
| 20.2    | Tracking .....   | 36 |
| 20.3    | User-written data.....   | 36 |
| 20.4    | User-read data.....  | 36 |
| Annex A | (informative) Pre-cure, post-cure method .....   | 37 |
| Annex B | (informative) Influence of birefringence measurement .....   | 39 |

|  |           |
|--|-----------|
| <b>Annex C (informative) Case for holographic data storage disk.....</b> | <b>41</b> |
| <b>C.1 Environmental conditions .....</b>                                | <b>41</b> |
| <b>C.2 Temperature shock .....</b>                                       | <b>41</b> |
| <b>Annex D (normative) Specific Disk Information .....</b>               | <b>43</b> |
| <b>Annex E (normative) Disk multiplex recording method .....</b>         | <b>45</b> |
| <b>Annex F (informative) Sync detection and resampling .....</b>         | <b>47</b> |
| <b>Annex G (informative) Inter-Page ECC .....</b>                        | <b>49</b> |
| <b>Annex H (informative) Intra-Page ECC .....</b>                        | <b>51</b> |
| <b>Annex I (informative) User capacity in one disk.....</b>              | <b>53</b> |
| <b>Annex J (normative) Finalizing data.....</b>                          | <b>55</b> |

## Introduction

In recent years, the generation and use of large volumes of data has expanded due to the sophistication of industries dealing with large-scale data bases associated with deep learning, video data from smartphone cameras and VR, etc., and the exchange of data over the Internet in connection with faster communication speeds.

With this growing data usage, the market for digital data storage is rapidly expanding, including large-scale industrial data centers for IoT, Big data, and cloud services, as well as cloud storage for personal use and personally managed storage. The market for data backup and archiving is also expanding.

Under these circumstances, malicious viruses have encrypted system memory in companies, hospitals, government offices, and individuals, rendering PCs and other devices unusable, resulting in business downtime and significant damage to recovery efforts. In addition, if the backup memory used is rewritable memory, that backup memory is also at risk of being encrypted. In this sense, the backup memory is desired to be physically write-once type and large-capacity.

The 120 mm size optical disk was available as a write-once type of media, and the increase in capacity was succeeded by CDs, DVDs, and BDs. However, even after the passage of the last decade or so, there has been no proposal to increase the capacity of optical disks after BD, and it is believed that the capacity increase using the conventional bit-by-bit method has reached its limit.

Under such circumstances, the holographic recording method was considered as one of the technologies to increase the capacity of optical disks, and in 2007, a 120 mm size holographic versatile disk (HVD) with a capacity of 200 GB was developed and established as an Ecma standard. This HVD has a method of forming holograms by interfering the signal beam and reference beam, which pass along the same optical axis of the objective lens, in a narrow area on the disk where both beams are focused. In contrast, a new hologram recording method that allows the interference area to expand in the direction of the recording layer thickness of the disk has been developed. This enables more efficient use of hologram recording materials, resulting in a significant increase in capacity.

This standard specifies the physical, optical and mechanical characteristics, embossed track and user data format, and recording and reading characteristics on a holographic data storage disk (HDSD) to enable data exchange between disks with a capacity of 1 Terabyte.

Compliance with this Standard may involve the use of a patent. Ecma International takes no position concerning the evidence, validity and scope of this patent right.

The holder of this patent right has assured Ecma International that he/she is willing to negotiate licences either free of charge or under reasonable and non-discriminatory terms and conditions with applicants throughout the world. In this respect, the statement of the holder of this patent right is registered with Ecma International. Information may be obtained from: <https://www.ecma-international.org/policies/ecma-list-of-patent-statements/>.

Attention is drawn to the possibility that some of the elements of this document may be the subject of patent rights other than those identified above. Ecma International shall not be held responsible for identifying any or all such patent rights.

This Ecma Standard was developed by Technical Committee 31 and was adopted by the General Assembly of June 2023.

## COPYRIGHT NOTICE

© 2023 Ecma International

*This document may be copied, published and distributed to others, and certain derivative works of it may be prepared, copied, published, and distributed, in whole or in part, provided that the above copyright notice and this Copyright License and Disclaimer are included on all such copies and derivative works. The only derivative works that are permissible under this Copyright License and Disclaimer are:*

- (i) works which incorporate all or portion of this document for the purpose of providing commentary or explanation (such as an annotated version of the document),*
- (ii) works which incorporate all or portion of this document for the purpose of incorporating features that provide accessibility,*
- (iii) translations of this document into languages other than English and into different formats and*
- (iv) works by making use of this specification in standard conformant products by implementing (e.g., by copy and paste wholly or partly) the functionality therein.*

*However, the content of this document itself may not be modified in any way, including by removing the copyright notice or references to Ecma International, except as required to translate it into languages other than English or into a different format.*

*The official version of an Ecma International document is the English language version on the Ecma International website. In the event of discrepancies between a translated version and the official version, the official version shall govern.*

*The limited permissions granted above are perpetual and will not be revoked by Ecma International or its successors or assigns.*

*This document and the information contained herein is provided on an "AS IS" basis and ECMA INTERNATIONAL DISCLAIMS ALL WARRANTIES, EXPRESS OR IMPLIED, INCLUDING BUT NOT LIMITED TO ANY WARRANTY THAT THE USE OF THE INFORMATION HEREIN WILL NOT INFRINGE ANY OWNERSHIP RIGHTS OR ANY IMPLIED WARRANTIES OF MERCHANTABILITY OR FITNESS FOR A PARTICULAR PURPOSE.*



# Holographic Data Storage Disk (HDSD) – Capacity: 1 Tbyte per disk

## 1 Scope

This Standard specifies the physical, optical and mechanical characteristics of a Holographic Data Storage Disk (HDSD) that employs holographic recording to enable data interchange between disks.

The 120 mm diameter holographic disk has a nominal capacity of 1 Tbyte.

This Standard specifies

- the conformance of recording disk, testing and the reference drive;
- the environments in which the disks are to be operated and stored;
- the mechanical, physical and dimensional characteristics of the disk;
- the format of embossed track information and user data information to be recorded on a disk;
- the holographic recording characteristics of the disk to enable data processing systems to record and read data on or from the disk;
- the minimum quality of user-recorded data on the disk, enabling data processing systems to read data from the disk.

## 2 Conformance

### 2.1 Holographic disk

A holographic disk shall be in conformance with this document if it meets all mandatory requirements specified in this Standard.

### 2.2 Recoding system

A hologram data recording system that produces HDSDs shall be in conformance with this document if it meets the mandatory requirements according to 2.1.

### 2.3 Reading system

A hologram data reading system that reads HDSDs shall be in conformance with this document if it is able to properly read the data recorded on the hologram disk according to 2.1.

## 3 Normative references

The following documents are referred to in the text in such a way that some or all of their content constitutes requirements of this document. For dated references, only the edition cited applies. For undated references, the latest edition of the referenced document (including any amendments) applies.

ECMA-287, *Safety of electronic equipment*, <https://www.ecma-international.org/publications-and-standards/standards/ecma-287/>

ECMA-328, *Detection and measurement of chemical emissions from electronic equipment*, <https://www.ecma-international.org/publications-and-standards/standards/ecma-328/>

## 4 Terms and definitions

For the purposes of this document, the following terms and definitions apply

### 4.1

#### **clamping zone**

annular part of the disk within which the clamping force is applied by the clamping device

### 4.2

#### **data page**

two-dimensional representation of digital bits data

### 4.3

#### **data page hologram**

hologram storing *data page* (4.2)

### 4.4

#### **data reading energy**

optical energy, incident at the entrance surface of the disk, of the hologram reading beam

### 4.5

#### **data recording energy**

optical energy, incident at the entrance surface of the disk for hologram recording

### 4.6

#### **entrance surface**

surface of the disk onto which the optical beams first incident

### 4.7

#### **Error Correction Code (ECC)**

mathematical computation yielding check bytes used for the detection and correction of errors in data

### 4.8

#### **finalizing**

operation after which no further recording is allowed

### 4.9

#### **fixing**

operation for deactivating the holographic recording material using of an illumination so that it is no longer sensitive to light

### 4.10

#### **holographic disk**

disk that records and holds information in the form of holograms in the recording layer

### 4.11

#### **holographic recording**

one of the optical data recording techniques that records interference fringes of signal beam modulated by digital page data and reference beams arranged in two dimensions on a disk as a hologram

### 4.12

#### **packet**

group of bytes and/or bits processed together during data encoding and/or decoding

### 4.13

#### **peristrophic multiplexing recoding**

method of multiplex recording different page data by changing the direction of the grating vector of interference fringes generated by the interference of signal beam and reference beam

**4.14****pit**

embossed mark on the land during the manufacture of the disk substrate

**4.15****pixel**

smallest independent element of a *data page* (4.2)

NOTE An "On-pixel" is an illuminated pixel and an "Off-pixel" is a non-illuminated pixel.

**4.16****reading beam**

beam used to reproduce the image stored in the recorded hologram

**4.17****recording layer**

layer of a disk that records data as holograms consisting of multiple layers of different materials or composite materials

**4.18****Reed-Solomon code (RS)**

error detection and correction codes

**4.19****reference beam**

beam that interferes with the signal beam on the hologram disk to form a hologram on the disk

**4.20****reference drive**

drive with well-defined properties used to test conformance to the standard of the record and read parameters of the disk

**4.21****reference axis**

axis passing through the centre of the centre hole of the disk and normal to the reference plane

**4.22****reference plane**

plane defined by a perfectly flat annular surface of the disk

**4.23****shift multiplexing recording**

method of multiplex recording by shifting the recording position of the holograms little by little in the tangential direction and radial direction of the track

**4.24****signal beam**

beam for hologram recording modulated by data input to DMD

**4.25****Specific Disk Information (SDI)**

manufacturing information recorded on the disk

**4.26****spindle**

part of the disk drive that contacts the disk

#### 4.27

##### **subpage**

subdivision of *data page* (4.2)

#### 4.28

##### **substrate**

transparent layer of the disk provided for the mechanical support of the recording layer

#### 4.29

##### **symbol**

encoding data unit of *data page* (4.2)

#### 4.30

##### **sync pattern**

pattern of data pixels used for synchronization of *data page* (4.2)

#### 4.31

##### **track**

pre-pit row with embedded information including address, SDI, hologram data recording/reading position, land field, etc.

#### 4.32

##### **tracking and focusing beam**

beam used to read the tracking and focusing error signal, addressing and *SDI* (4.25) data

#### 4.33

##### **track pitch**

distance between adjacent track centrelines, measured in a radial direction

## 5 Abbreviated terms

|      |                                 |
|------|---------------------------------|
| AOM  | Acoustic Optical Modulator      |
| CMOS | Complementary MOS sensor        |
| DBS  | Dichroic Beam Splitter          |
| DMD  | Digital Mirror Device           |
| ECDL | External Cavity Diode Laser     |
| LDPC | Low Density Parity Check (code) |
| LSB  | Least Significant Byte          |
| Lsb  | least significant bit           |
| MSB  | Most Significant Byte           |
| Msb  | most significant bit            |
| PBS  | Polarizing Beam Splitter        |

## 6 Conventions and notation

A measured value is rounded off to the least significant digit of the corresponding specified value. For instance, it implies that a specified value of 1,26 with a positive tolerance of + 0,01 and a negative tolerance of - 0,02 allows a range of measured values from 1,235 to 1,275.

Numbers in decimal notations are represented by the digits 0 to 9.

Numbers in hexadecimal notation are represented by the hexadecimal digits 0 to 9 and A to F in parentheses.

The setting of bits is denoted by ZERO and ONE.

Numbers in binary notations and bit patterns are represented by strings of digits 0 and 1, with the most significant bit shown to the left.

Negative values of numbers in binary notation are given as Two's complement.

In each field the data is recorded so that the most significant byte (MSB), identified as Byte 0, is recorded first and the least significant byte (LSB) last. In a field of  $8n$  bits, bit  $b_{(8n-1)}$  shall be the most significant bit (msb) and bit  $b_0$  the least significant bit (lsb). Bit  $b_{(8n-1)}$  is recorded first.

A binary digit which can be set indifferently to ZERO or to ONE is represented by "x".

## 7 General description of hologram disk and its data recording and reading method

The holographic disk covered by this standard consists of a recording layer, a track for positioning at data recording and reading, a reflective layer, and a substrate arranged above and below to physically protect these layers (see Figure 6).

Two-dimensional digital data is recorded as a hologram with refractive index change (holographic fringe) in the volume of the recording layer of the disk by the interference between a signal beam modulated in two dimensions by a digital mirror device (DMD) and a spherical reference beam. DMD is a device used to modulate the intensity of a light beam according to a spatially two-dimensional pattern. Such recording is continuously performed with the shift-multiplex recording [1] and peristrophic multiplexing recording [2]. Details of these hologram recording methods are given in 13.2 and Annex E.

The recorded holograms are read by a spherical reference beam as data reading beam using the diffraction effect from the holograms, and the data reading beam enters a two-dimensional optical sensor complementary MOS (CMOS) image sensor through a transparent substrate from the recording layer, and is detected and reproduced by the sensor.

In order to guide the hologram recording signal beam and the reference and reading beam to a predetermined position on the disk, a tracking and focusing control mechanism is provided to read the address data recorded as pits on the track and perform tracking and focusing control.

## 8 General requirement

### 8.1 General

This clause describes the environmental conditions during hologram recording, reading and disk storage.

### 8.2 Environment

#### 8.2.1 General

The operating, storage, transportation and temperature shock environment has the following properties.

#### 8.2.2 Operating environment

The operating environment shall be the environment where air immediately surrounding the holographic disk mounted on the drive has the following properties.

Temperature 30°C to 40°C

Atmospheric pressure 60 kPa to 106 kPa

|                   |                                   |
|-------------------|-----------------------------------|
| Relative humidity | 20 % to 80 %                      |
| Absolute humidity | 25 g/m <sup>3</sup> max           |
| Ambient light     | 0,007 lx; (1 nW/cm <sup>2</sup> ) |
| Air cleanliness   | office environment                |

No condensation on the holographic disk occurs. If a holographic disk has been exposed during storage and/or transportation to a condition outside the above values, before use the disk shall be conditioned in the operating environment for a time at least equal to the period during which it has been out of the operating environment, up to a maximum of 24 h.

### 8.2.3 Storage environment

Holographic disk cartridges containing holographic disk shall not be stored in an environment outside the range allowed for storage. The storage environment is defined as an environment where the air immediately surrounding the holographic disk cartridge has the following properties.

|                      |                                  |
|----------------------|----------------------------------|
| Temperature          | 16°C to 32 °C                    |
| Atmospheric pressure | 60 kPa to 106 kPa                |
| Relative humidity    | 20 % to 40 %                     |
| Absolute humidity    | 25 g/m <sup>3</sup> max.         |
| Ambient light        | 925 lx (135 µW/cm <sup>2</sup> ) |
| Air cleanliness      | office environment               |

No condensation on the holographic disk occurs.

NOTE Disk is packaged in the cartridge (see Clause 11 and Annex C).

### 8.2.4 Transportation

It is desirable that transportation is carried out in an environment similar to the storage environment.

### 8.2.5 Temperature shock

The holographic disk shall withstand a temperature shock of up to 10 °C when inserted into, or removed from the drive.

## 8.3 Safety requirement

The disk shall satisfy the safety requirements of Standards ECMA-287 and ECMA-328, when used in the intended manner or in any foreseeable use in an information processing system.

## 8.4 Flammability

The cartridge and its components shall be made from materials that comply with the flammability class for HB materials, or better, as specified in Standard ECMA-287.

## 9 Reference drive

### 9.1 General

The reference drive shall be the drive used to test the record and read parameters of disks conforming to this standard. This clause provides an overview of the configuration and operation of the reference drive, as well as an overview of the key components used in this drive and their specifications.

### 9.2 Optical system

The optical system of the reference drive consists of a hologram recording and reading channel used for measuring the record and read parameters shown in Figure 1, and a tracking and focusing signal detection channel shown in Figure 2.

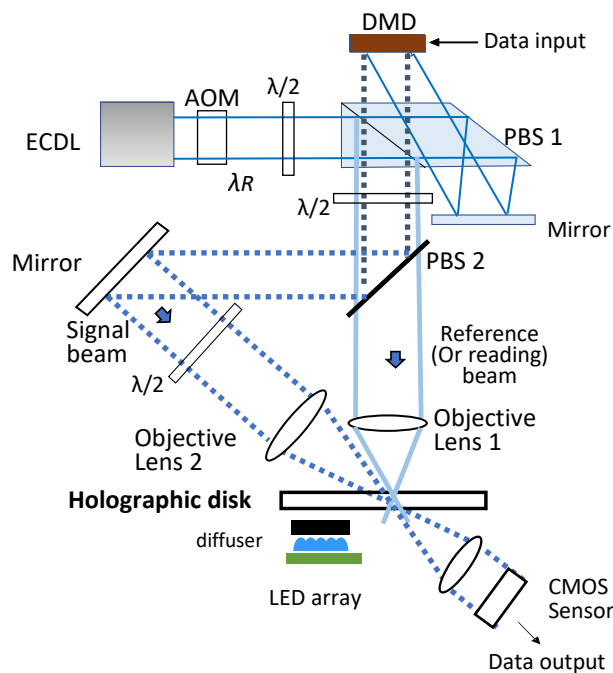

**Figure 1 – The configuration of reference drive for recording and reading channel**

The hologram recording and reading channel optical system mainly consists of a wavelength tuneable external cavity diode laser (ECDL), acoustic optical modulator (AOM), polarizing beam splitter (PBS), digital mirror device (DMD), CMOS image sensor and photosensitive LED array. The polarizing beam splitter (PBS1) separates the signal and reference beam. The signal beam is modulated by DMD. The recording and reading time are modulated by AOM. As shown, the signal beam and the reference beam pass through the same optical axis until just before PBS2. The both beam path is separated by the PBS2. The reference beam passes through PBS2, and focuses on the disk via objective lens1. On the other hand, the signal beam is reflected by PBS2 and focused on the disk by objective lens 2. Reference beam's wave front is spherical on the medium. Both beams interfere in the holographic disk and the data page is recorded as hologram. The hologram multiplexing recording is carried out. The recorded hologram is read out by using a spherical reference beam, and the data recorded as two-dimensional data on the data page is reproduced by a CMOS image sensor installed on the back side of the media. The optical system shall be such that the detected light reflected from the entrance surface of the disk is minimized so as not to influence the accuracy of the measurements. In addition, LED array is installed for pre-curing to activate the media before recording hologram data and for post-cure for fixing the recorded holograms.

The tracking and focusing signal detection channel optical system shown in Figure 2 consists of a red laser diode (RLD) for the tracking, focusing and addressing, a dichroic beam splitter (DBS), a collimated lens, and a 4 split photodetector. The red laser beam from the RLD, i.e., tracking and focusing beam, is illuminated onto the hologram disk via optics such as PBS, DBS, etc. as shown in Figure 2. The laser beam reflected by the disk

enters the photo detector through an optical path similar to the incident optical path. The DBS has a reflectance of at least 99 % for the RLD wavelength  $\lambda_r$  and a transmittance of at least 98 % for the recording and reading wavelength  $\lambda_r$ .

Using the signal detected by the 4 split photodetector, tracking error, focus error, and address and SDI signals are detected. Details of these signals above are described in 16.4.

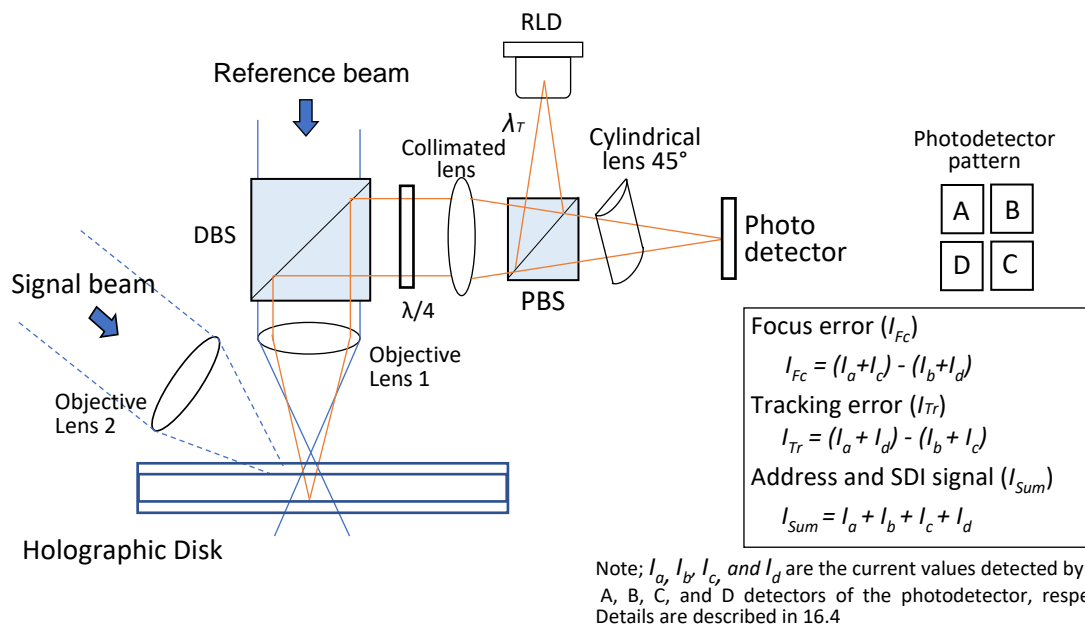

**Figure 2 – The configuration of tracking and focusing signal detection channel optical system**

The configuration of total optical system is shown in Figure 3. The optical axis of the reference beam, reading beam and the optical axis of the signal beam shall cross each other at the axial centre of the recording layer. The tracking and focusing beam shall also pass on the same optical axis as the reference beam and reading beam.

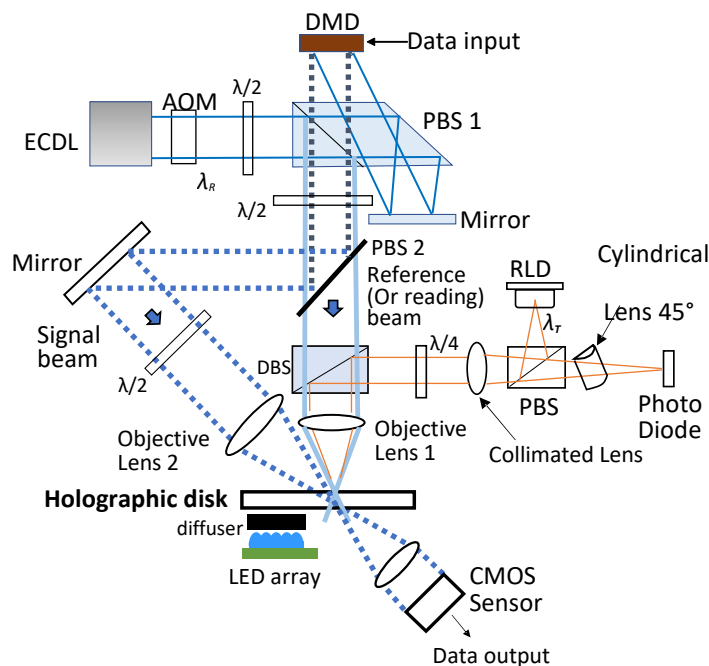

**Figure 3 – Total optical system**



### 9.3 Hologram recording and reading channel

#### 9.3.1 General

The hologram recording channel (shown in Figure 1) shall be used to record the hologram of the data page image generated by the DMD. The hologram reading channel (shown in Figure 1) shall be used to read the hologram of the data page image reproduced from the medium. The reproduced signal is detected by CMOS image sensor.

#### 9.3.2 Signal beam

The signal beam is the pulsed laser beam used for data recording and shall have the following characteristics at the surface of the disk.

|  |   |
|--|---|
| Wavelength ( $\lambda_R$ )   | 405 nm $\pm$ 0,1 nm   |
| Polarization   | S-polarization  |
| Light intensity at the rim of the pupil of the objective lens  | $\geq$ 55 % of the maximum intensity level, in radial and tangential directions |
| Wave front aberration from an ideal spherical wave front after passing through an ideal stack of disk layers | 0,012 $\lambda$ rms max.  |
| Coherent length  | $\geq$ 100 mm   |
| Laser pulse width  | < 10 $\mu$ s at half maximum  |
| Laser pulse energy   | 0,5 $\mu$ J   |
| Incident angle   | 45 degrees to reference axis A  |

#### 9.3.3 Reference beam and reading beam

The reference and reading beams are pulsed laser beams, with the reference beam used for data recording and the reading beam used for hologram data reading and shall have the following characteristics at the surface of the disk.

|  |  |
|--|--|
| Wavelength ( $\lambda_R$ )   | 405 nm $\pm$ 0,1 nm  |
| Polarization   | S-polarization   |
| Light intensity at the rim of the pupil of the objective lens  | $\geq$ 55% of the maximum intensity level, in radial and tangential directions |
| Wave front aberration from an ideal spherical wave front after passing through an ideal stack of disk layers | 0,012 $\lambda$ rms max.   |
| Coherent length  | $\geq$ 100 mm  |
| Laser pulse width  | < 10 $\mu$ s at half maximum   |
| Laser pulse energy   | 0,5 $\mu$ J  |
| Incident angle   | 0 degree to reference axis A   |

### 9.3.4 Objective lens

Objective Lens 1 and Objective Lens 2 shown in Figure 1 and Figure 3 are used to focus the reference beam and signal beam on the disk, respectively, and to interfere with each other's beams on the disk.

Objective lens 1 shall have the following characteristics.

Focal length 30 mm  $\pm$  0,2 mm

Numerical aperture 0,3  $\pm$  0,01

Objective lens 2 shall have the following characteristics

Focal length 30 mm  $\pm$  0,2 mm

Numerical aperture 0,3  $\pm$  0,01

### 9.3.5 Digital Mirror Device (DMD)

A DMD modulates the signal beam to record image data (data page), which represents a data pattern, onto the recording layer in the form of a hologram. A hologram is formed by a fringe pattern created by the interference between the spherical reference beam and the signal beam modulated by the DMD.

The DMD shall have the following characteristics (shown in Figure 4).

DMD usage area 1 520 pixels x 1 520 pixels at the centre part of DMD

Pixel pitch 7,56  $\mu$ m  $\pm$  0,02  $\mu$ m for both horizontal (tangential) and vertical (radial) direction

Fill factor 85,2 %  $\pm$  0,1 %

Modulation ratio more than 500 at on/off pixels produced by the DMD

The DMD size can be any size as long as the required DMD usage area is provided. In Figure 4, the DMD size is shown as 2 650 pixels x 1 600 pixels.

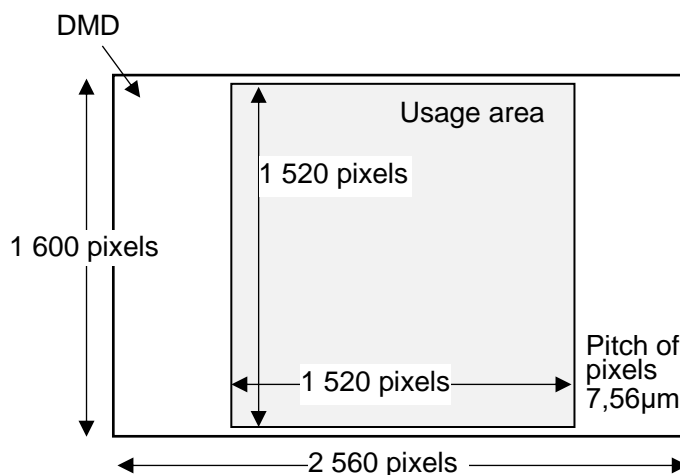

**Figure 4 – DMD shape and usage area (data page area)**

### 9.3.6 Hologram reading channel

The hologram reading channel reconstitutes the image from the recorded hologram and read out the recorded data. The CMOS image sensor is used to detect data pattern recorded as a hologram on the recording layer.

The CMOS image sensor shall have the following characteristics (shown in Figure 5).

|                        |   |
|------------------------|---|
| Hologram detected area | 3 040 pixels×3 040 pixels at centre area of CMOS image sensor           |
| Pixel pitch            | 4,5 µm for both horizontal (tangential) and vertical (radial) direction |

The signal generated by each pixel of sensor shall be linearly related to the energy received by this pixel during readout. The size of sensor can be any size as long as the required sensor usage area is provided. In Figure 5, the CMOS image sensor size is shown as 5 120 pixels × 4 096 pixels.

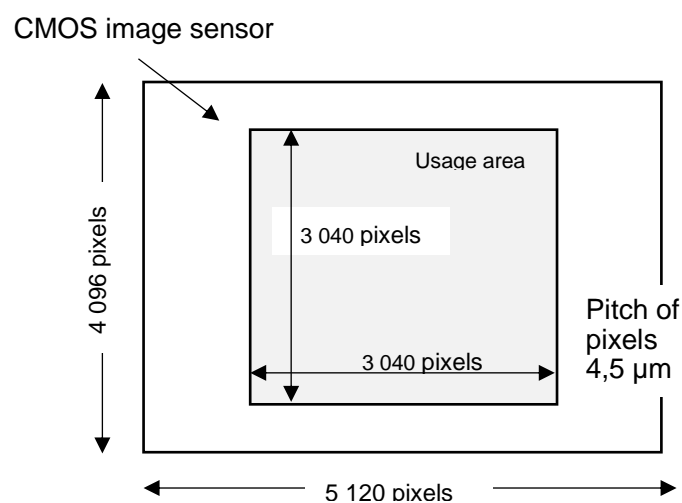

Figure 5 – CMOS image sensor shape and usage area

## 9.4 Tracking and focusing signal detection channel

### 9.4.1 General

The tracking and focusing signal detection channel shown in Figure 2 shall be used to generate tracking and focusing error signal for accurate control of the recording and playback position of holograms and read address and SDI data.

### 9.4.2 Tracking, focusing signal and address and SDI data

The radial tracking and focusing error signals and the address and SDI data can be obtained as a result of the appropriate combination calculations shown in Figure 2 for the output signals of the 4 split photodetectors, the division of which runs parallel to the image of the tracks on the detector. The address and SDI data shall be derived from the reading of the data embossed in tracks as pre-pits in advance shown in Figure 7.

### 9.4.3 Tracking and focusing beam

The laser beam used for tracking and focusing signal detection channel shall have the following characteristics at the surface of the disk.

|                            |                                |
|----------------------------|--------------------------------|
| Wavelength ( $\lambda_T$ ) | 650 nm (max +10nm, min. - 5nm) |
|----------------------------|--------------------------------|

|   |  |
|---|--|
| Polarization  | S-polarization   |
| Focal length of objective lens  | 30 mm $\pm$ 0,2 mm   |
| Numerical aperture  | 0,3 $\pm$ 0,01   |
| Light intensity at the rim of the pupil of the objective lens   | $\geq$ 40 % of the maximum intensity level in the radial direction, and<br><br>$\geq$ 40 % in the tangential direction |
| Wave front aberration from an ideal spherical wave front after passing through an ideal stack of disk | 0,033 $\lambda$ rms max.   |
| Relative Intensity Noise (RIN)  | -126 dB/Hz max.  |
| Tracking and focusing beam power  | 0,5 mW $\pm$ 0,2 mW  |

## 9.5 Conditions for measuring the operational signals

### 9.5.1 Axial and radial deviation of tracking and focusing beam

During the measurement of the tracking and focusing error signal, the tracking and focusing beam shall have an axial deviation  $e_{max}$  (axial) not more than 0,23  $\mu$ m from the embossed pits on reflective layer.

The tracking and focusing beam shall have a radial deviation  $e_{max}$  (radial) of not more than 0,022  $\mu$ m from the centre of the track.

### 9.5.2 Relative positions of the signal beam and the tracking and focusing beams during data recording

During data recording, the relative positioning of the centres of the focus of the signal beam and the tracking and focusing beam shall be such that their axial misalignment shall be less than  $\pm$  1,0  $\mu$ m. The focal point of the signal beam is the point where the optical axes of the signal and reference beams have crossed. The misalignment of signal and reference beams shall be less than  $\pm$  1,0  $\mu$ m in both radial and axial directions.

### 9.5.3 Relative positions of the reading beam and the tracking and focusing beams during data reading

During data reading, the relative positioning of the centres of the focus of the reading beam and the tracking and focusing beam shall be such that their axial misalignment shall be within  $\pm$  1,0  $\mu$ m, and their radial misalignment shall be less than  $\pm$  1,0  $\mu$ m and tangential misalignment shall be less than  $\pm$  0,1  $\mu$ m.

## 9.6 Pre-cure and post-cure

Pre-cure for activating the material of recording layer of the disk shall be carried out just before the data recording and post-cure for fixing shall be done after completion of multiplexed recording shown in Annex A. Both processes are carried out at the data recording zone. For Lead-in zone and Lead-out zone are also pre-cured and post-cured by the same LED energy with the User Data Zone. Details on these zone formats are described in Clause 14.

NOTE Pre-cure and post-cure shall be done not only on the reference drive but on the any HDSD drives.

## 10 Dimension, mechanical, optical and physical characteristics of disk

### 10.1 General

The configuration, mechanical and optical characteristics of the disk medium on which the holograms are recorded are specified in Clause 10.

### 10.2 General configuration of the disk

#### 10.2.1 Configuration of the disk

The disk shall consist of a circular substrate with a hole in the centre, bearing a stack of layers incorporating the holographic recording layer shown in Figure 6. The lower substrate has track for recording and reading positioning in which address and SDI data are pre-recorded as embossed pits. The reflective layer constituted by dichroic thin film exists on the lower substrate. This layer reflects the Tracking and focusing beam and passes through the signal and reference beam.

The disk has the following characteristics.

|                              |        |
|------------------------------|--------|
| Disk diameter                | 120 mm |
| Disk thickness               | 2,7 mm |
| Substrate thickness          | 0,6 mm |
| Thickness of recording layer | 1,5 mm |

The centring of the disk on the drive spindle is performed on the edge of the centre hole of the substrate. Clamping is performed in the Clamping Zone. The clamping zone is an annular part of the disk within which the clamping force is applied by the clamping device.

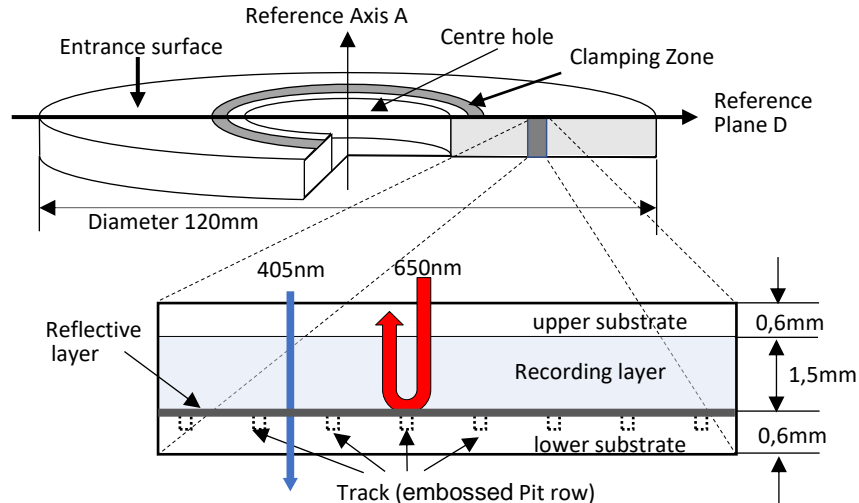

Figure 6 – Configuration of the disk

#### 10.2.2 Track arrangement on a disk

A track is formed by a row of embossed pits with data pits and land fields recorded in concentric circles around the entire disk shown in Figure 7.

Track shall have the following characteristic as shown in Figure 8.

|                       |   |
|-----------------------|---|
| Track arrangement     | concentric tracks   |
| Track location        | from radius 20,0 mm at innermost track to radius 59,0 mm at outermost track |
| Track pitch           | 100 $\mu\text{m} \pm 1,0 \mu\text{m}$                                       |
| Total number of track | 391 tracks  |

These tracks are divided into a Lead-in zone, a test zone, a user zone for recording and playing back holographic data, and a Lead-out zone, in order from the inner to the outer area of the disk., as shown in 14.1. The disk rotates at a constant linear velocity of 5,69 mm/s. The rotating speed of the disk is 2,72 rpm at the innermost track with a radius of 20 mm and 0,91 rpm at the outermost track with a radius of 59,0 mm. The direction of rotation of the disk is counter-clockwise when viewed from the objective lens.

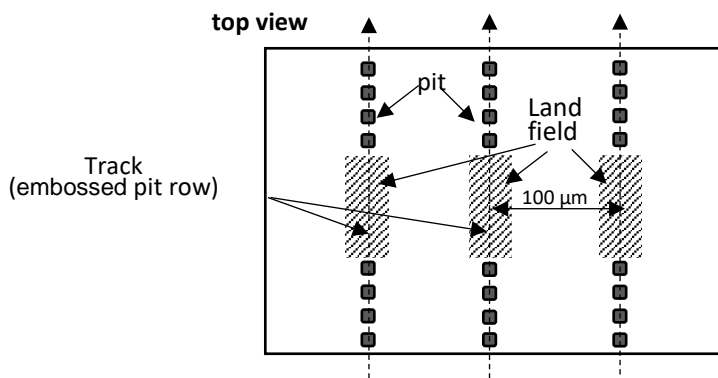

**Figure 7 – Configuration of the track**

Each track is divided into n sectors, the details for each sector are described in Clause 12.

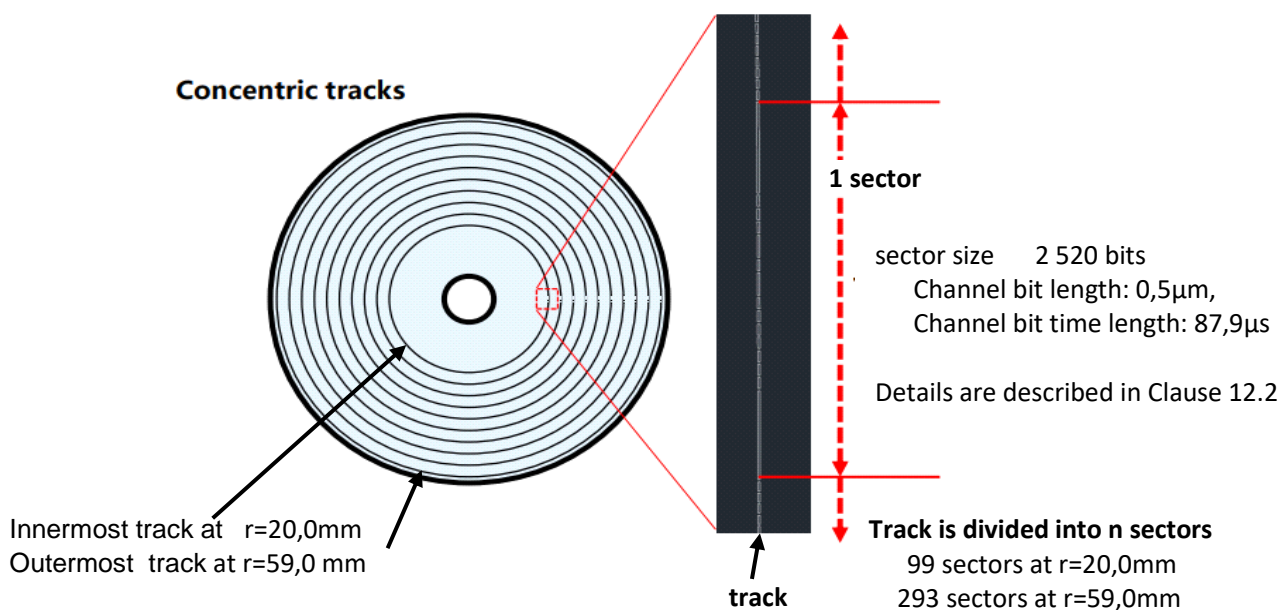

**Figure 8 – Schematic diagram of track arrangement on a disk**

### 10.3 Reference axis and reference plane of the disk

Reference plane D is defined by the perfectly flat annular surface. The clamping zone of the disk is formed on the Reference plane D.

Reference axis A of the disk passes through the centre of the centre hole of the disk, and is normal to reference plane D.

## 10.4 Dimensions of the disk

The dimensions of the disk shall be measured in the operating environment.

The outer diameter of the disk,  $D_1$  shall be

$$D_1 = 120 \text{ mm} \pm 0,30 \text{ mm}$$

The centre hole,  $D_2$  shall have a diameter of

$$D_2 = 15,00 \text{ mm} + 0,10 \text{ mm}, - 0,00 \text{ mm}$$

There shall be no burr on the edge of the centre hole.

The edge of the centre hole shall be rounded off or chamfered. The rounding radius shall be 0,1 mm max. The chamfer extends over a height of 0,1 mm max.

The total thickness of the disk,  $D_5$  shall be 2,5 mm min. and 2,9 mm max.

$D_5$  is a combination of two  $0,6 \text{ mm} \pm 0,05 \text{ mm}$  thickness upper and lower substrates and a  $1,5 \text{ mm} \pm 0,1 \text{ mm}$  thickness recording layer, as shown in Figure 6. The dimension of the thickness of the disk  $D_5$  shall be referred to the reference plane D, as shown in Figure 9.

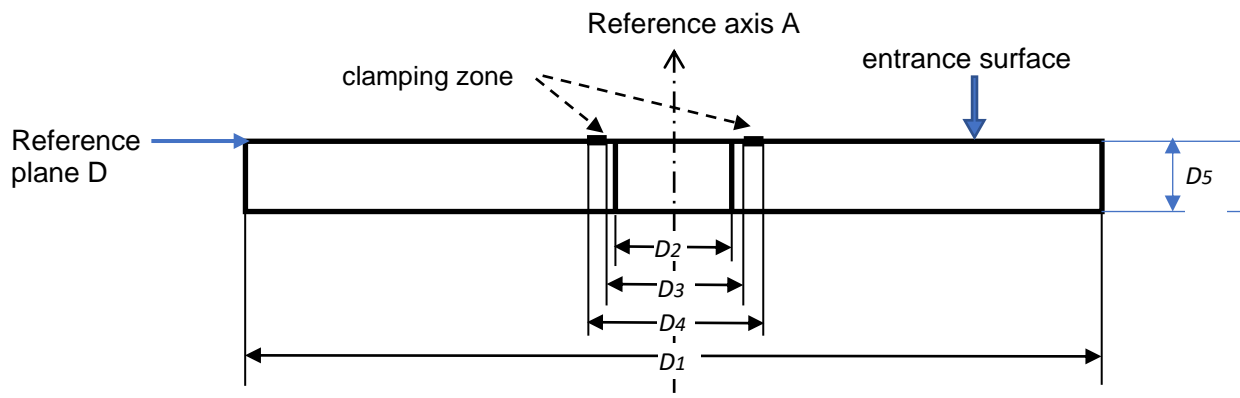

Figure 9 – Dimensions of the disk

## 10.5 Clamping zone

The clamping zone is the area on the entrance surface of the disk where the clamping mechanism of the drive grips the disk and shall be defined by  $D_3$  and  $D_4$  (see Figure 9).

The clamping zone from the outer diameter ( $D_3$ ) to the inner diameter ( $D_4$ ) of the clamping zone is excluded from the total thickness requirement as shown in Figure 9. However, there shall be no projection from the Reference plane D in the direction of the optical system of more than 0,2 mm in this zone.

The inner diameter of the clamping zone  $D_3$  is

$$D_3 = 24 \text{ mm} \pm 0.1 \text{ mm}$$

The outer diameter of the clamping zone  $D_4$  is

$$D_4 = 30 \text{ mm} \pm 0.1 \text{ mm}$$

## 10.6 Mechanical characteristics

### 10.6.1 Material

The disk shall be made from any suitable materials such that it meets the requirements of this Standard.

### 10.6.2 Mass

The mass of the disk is not exceeded 120 g.

### 10.6.3 Axial deflection

The axial deflection of the disk is measured under operating environment as the axial misalignment of the tracks. It comprises the tolerances on the thicknesses of the crossed layers, on their indexes of refraction, and the deviation of the entrance surface from the Reference plane D. The deviation of any point of the track from its nominal position, in a direction normal to the Reference plane D, shall not exceed  $\pm 0,1$  mm in the track for rotational frequencies of the disk. The deviation shall be measured by the optical system defined in Figure 2.

### 10.6.4 Radial runout

The radial runout of the tracks is measured under operating environment as seen by the Reference drive's optics. It includes the distance between the axis of rotation of the spindle and Reference axis A, the tolerances on the dimensions between Reference axis A and the location of the track, and effects of non-uniformities in the index of refraction of the stack of layers.

The radial runout is the difference between the maximum and the minimum distance of any track from the axis of rotation, measured along a rigid radial line over one track. The radial runout shall not exceed 100  $\mu\text{m}$ .

### 10.6.5 Angular deviation

Angular deviation in the operating environment is defined as the relationship between the incident beam of 1 mm diameter perpendicular to the reference plane D and the reflected beam, which shall not exceed  $0,80^\circ$  in the radial direction and  $0,30^\circ$  in the tangential direction, in the track.

## 10.7 Optical characteristics

### 10.7.1 Substrate

The thickness of the substrate is  $0,6 \text{ mm} \pm 0,05 \text{ mm}$ . Within the Formatted Zone shown in Clause 14, to the signal beam and reference beam, the refractive index of the substrate shall be in the range of 1,49 to 1,6, and the difference in refractive index between the recording layer and the substrate ( $\Delta n_{rs}$ ) shall be  $\Delta n_{rs} < 0,1$ . The anti-reflection coating on both side is needed. The reflectance of all beams entering the substrate shall be lower than 3 % on both sides, and the transmittance shall be higher than 90 % for signal, reference and tracking and focusing beams.

The change in the polarization ratio of the reference beam and the signal beam, occurred by birefringence in the substrate, shall be suppressed so that the interference intensity at the time of recording is 30 % or less reduction.

The S-polarization ratio  $R$  shall be:

$$R = P_S / (P_S + P_P)$$

Where  $P_S$  is S-polarized beam intensity,  $P_P$  is P-polarized beam intensity.

The interference intensity  $P_{in}$  shall be:

$$P_{in} = \sqrt{R(\text{signal})} \times \sqrt{R(\text{reference})} > 0,7$$



The method of measuring the polarization ratio is shown in Annex B.

### 10.7.2 Reflective layer

The reflectance of reflective layer within the formatted zone as described in Clause 14 shall be at least 99 % at wavelength  $\lambda_T$ . The transmittance of the signal and reference beam within the formatted zone shall be at least 98 % at wavelength  $\lambda_R$ .

### 10.7.3 Recording layer

The recording layer is generally a photosensitive material at wavelength  $\lambda_R$  for signal beam and spherical reference beam (recording beam) and non-sensitive for the wavelength  $\lambda_T$  for tracking and focusing beams. Holograms are recorded as a change in refractive index or transmittance. Typical materials are photopolymerizable monomers with photo initiators.

## 11 Interface between cartridge and drive

### 11.1 General

This standard does not specify disk cartridges, but items 11.1 through 11.3 below shall be appropriately achieved. The case conforming to this standard meets the requirements shown in Annex C.

### 11.2 Clamping method

When the cartridge is inserted into the drive, the shutter of the Cartridge is opened and the drive spindle engages the disk. The disk is held against the spindle by an axial clamping force. The radial positioning of the disk is provided by the centring of the axis of the spindle in the centre hole of the disk. A turntable of the spindle supports the disk in its Clamping zone, determining the axial position of the disk in the Cartridge.

### 11.3 Tapered cone for disk clamping

The device used for centring the disk for test measurements shall be a cone.

### 11.4 Clamping force

The clamping force exerted by the spindle shall be less than  $2,0 \text{ N} \pm 0,2 \text{ N}$ .

## 12 Track format

### 12.1 General

This clause describes the track format in which address information, SDI data, etc. are embedded in the form of pre-pit to position holographic data for recording and reading.

One channel bit shall be set  $0,5 \mu\text{m}$  length (bit time length  $87,9 \mu\text{s}$ ). There are 249 480 channel bits embedded in the innermost track with a radius of  $20,0 \text{ mm}$  and 738 360 channel bits embedded in the outermost track with a radius of  $59,0 \text{ mm}$ . Each track shall be divided into  $n$  sectors.

NOTE The physical specifications of the embossed pit shall be set to meet the tracking and focusing signal requirements given in Clause 17. The minimum pit length is  $1 \mu\text{m}$  since it is NRZI encoded.

## 12.2 Sector format

### 12.2.1 Sector

Each sector shall be 2 520 channel bits of data length. i.e., the innermost track with a radius of 20,0 mm is divided into 99 sectors, and the outermost track with a radius of 59,0 mm is divided into 293 sectors.

### 12.2.2 Sector layout

One sector shall be divided into four fields; such as Header field; 184 channel bits, which indicates the address of the disk, Sync field; 40 channel bits, SDI/timing data mark field, which records SDI information or timing information for recording and reading out holographic data; 2 290 channel bits, and Land field; 6 channel bits as shown in Table 1.

SDI data shown in Annex D is embedded in the form of pre-pit in the SDI / timing data mark field in the Lead-in Zone.

Tracks in Formatted Zones other than the Lead-in zone described in Clause 14 have hologram recording and read-out timing data marks embedded in the SDI/timing data mark fields.

**Table 1 – Sector layout**

| Sector                 |        |      |                              |  | total Channel bits = 2 520 |
|------------------------|--------|------|------------------------------|--|----------------------------|
| field                  | Header | Sync | SDI / timing data mark field |  | land                       |
| Number of Channel bits | 184    | 40   | 2 290                        |  | 6                          |

### 12.2.3 Header

The Header shall consist of four fields; such as Address mark field; 48 channel bits, Address data field; 64 channel bits, ECC field; 32 channel bits, and reserve field; 40 channel bits shown in Table 2.

**Table 2 – Header layout**

| Header                 |              |              |     |                | total Channel bits = 184 |
|------------------------|--------------|--------------|-----|----------------|--------------------------|
| field                  | Address Mark | Address data | ECC | Reserved field |                          |
| Number of Channel bits | 48           | 64           | 32  | 40             |                          |

#### 12.2.3.1 Address Mark

The Address Mark shall consist of a pattern that does not occur elsewhere in the sector. It shall have length of 48 Channel bits with the pattern shown in Figure 10.

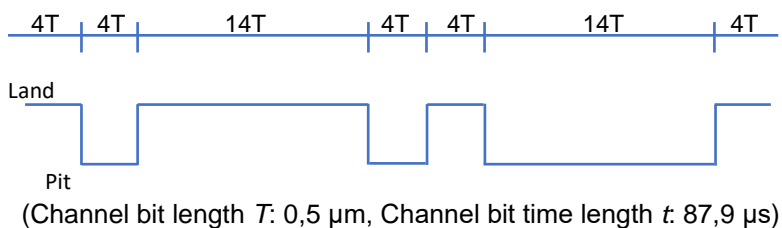

**Figure 10 – Address Mark pattern**

### 12.2.3.2 Address data

The Address data format shall be described in Table 3. The track address of the first track at innermost radius is 0. The track addresses located at radius larger than Track 0 are incremented by 1 for each track.

**Table 3 – Address data**

| Address data           |                | total Channel bits = 64 |                 |                 |
|------------------------|----------------|-------------------------|-----------------|-----------------|
| field                  | Track number H | Track number L          | Sector number H | Sector number L |
| Number of Channel bits | 16             | 16                      | 16              | 16              |

The higher 16 bits, Track Number H, of Track Number data bits are generated as shown in Figure 11.

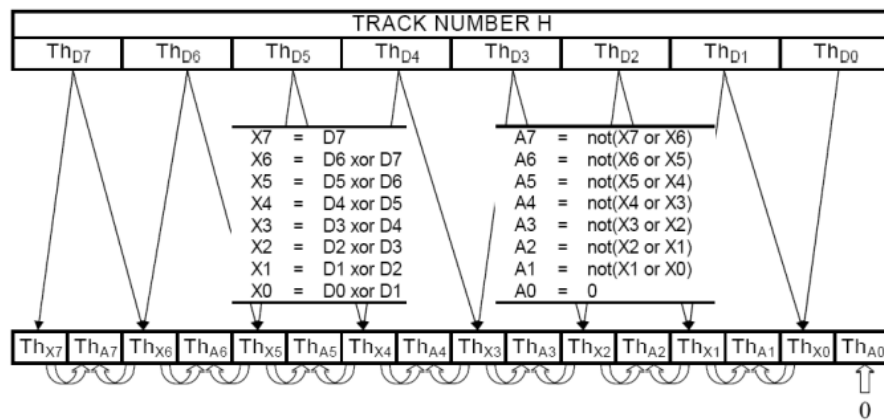

**Figure 11 – Track Number H**

The lower 16 bits, Track Number L, of Track Number data bits are generated as shown in Figure 12.

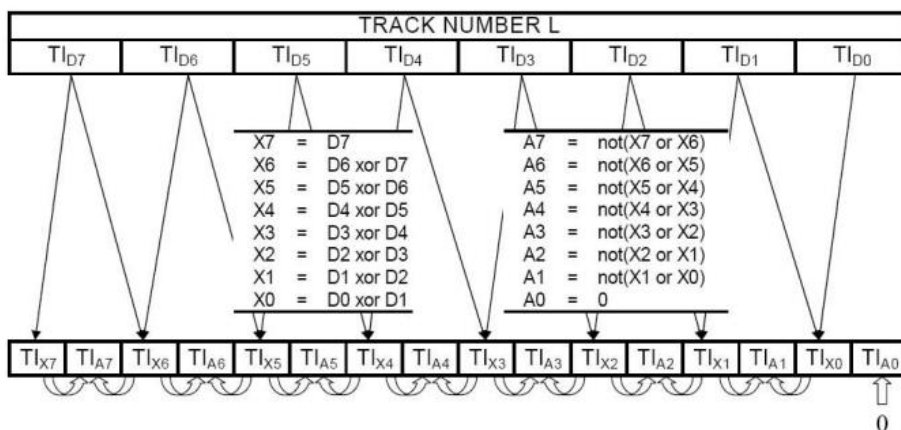

**Figure 12 – Track Number L**

The higher 16 bits, Sector Number H, of Sector Number data bits are generated as shown in Figure 13.

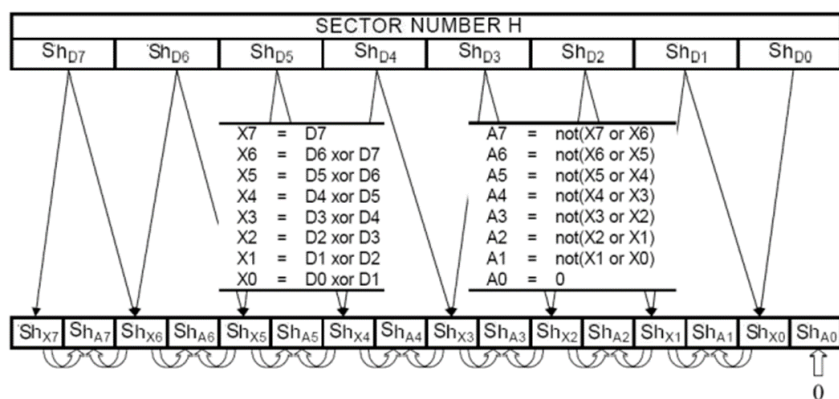

Figure 13 – Sector Number H

The lower 16 bits, Sector Number L, of Sector Number data bits are generated as shown in Figure 14.

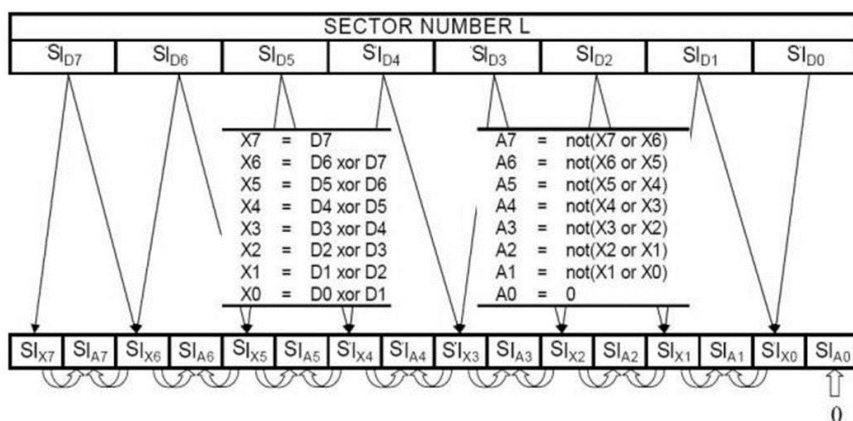

Figure 14 – Sector Number L

### 12.2.3.3 ECC

The ECC data format shall be described in Table 4.

Table 4 – ECC data format

| ECC                    |                       |                       |                        |                        | total Channel bits = 32 |  |  |  |
|------------------------|-----------------------|-----------------------|------------------------|------------------------|-------------------------|--|--|--|
| field                  | Track number H<br>ECC | Track number L<br>ECC | Sector number H<br>ECC | Sector number L<br>ECC |                         |  |  |  |
| Number of Channel bits | 8                     | 8                     | 8                      | 8                      |                         |  |  |  |

The higher digits of ECC data bits are generated as shown in Figure 15.

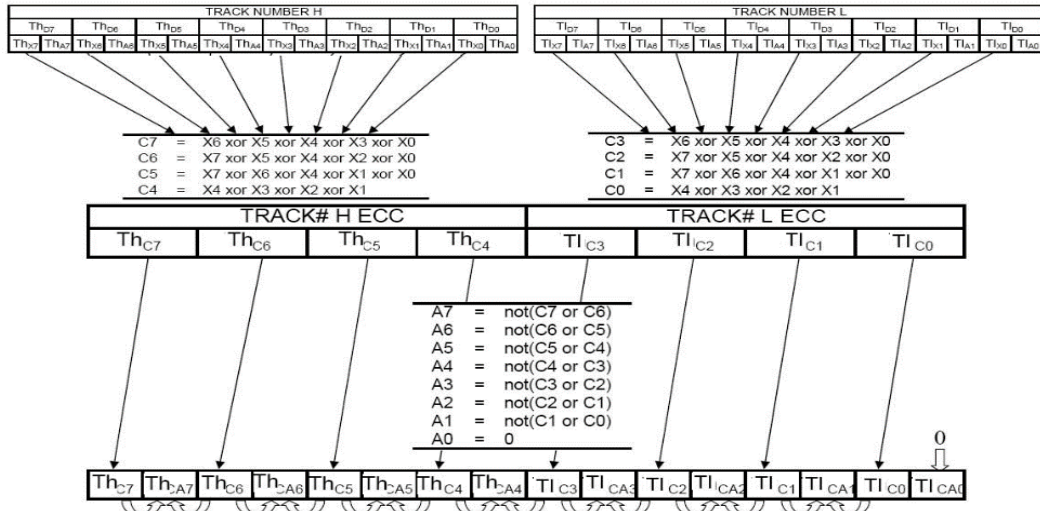

Figure 15 – Higher digits of ECC data

The lower digits of ECC data bits are generated as shown in Figure 16.

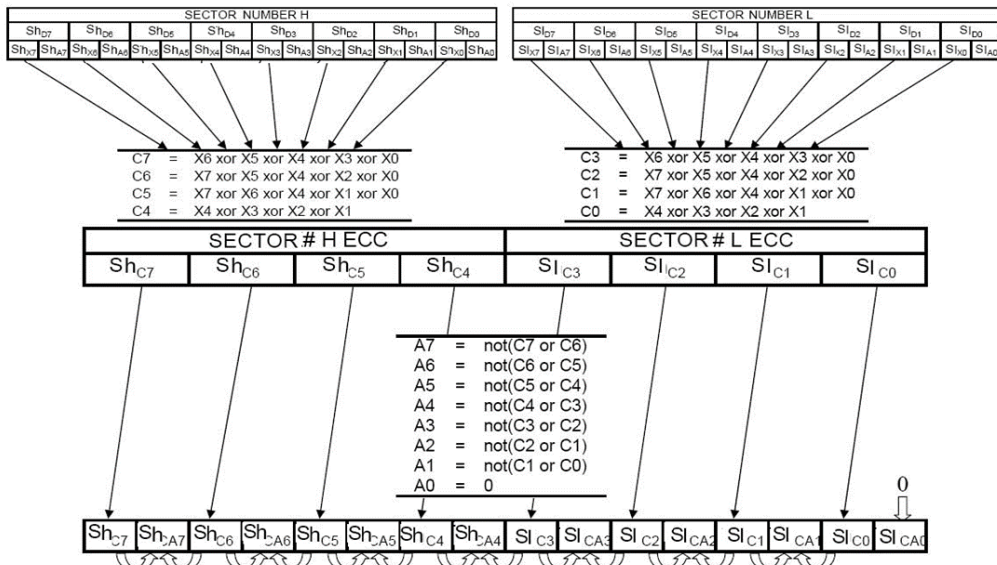

Figure 16 – Lower digits of ECC data

### 12.2.3.4 Reserved field

The reserved field shall be set to 0 of 40 Channel bits length.

### 12.2.4 Sync field

This field shall have a 40 channel bits length and consists of a 3T/16T/16T/5T land/pit pattern, as shown in Figure 17.

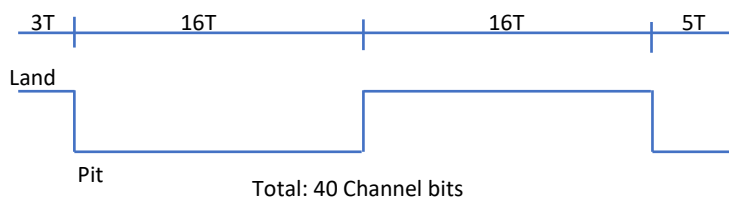

Figure 17 – Sync pattern

### 12.2.5 Timing data mark field

This field shall have a 2 290 channel bits length and consists of a 5T pit pattern, as shown in Figure 18.

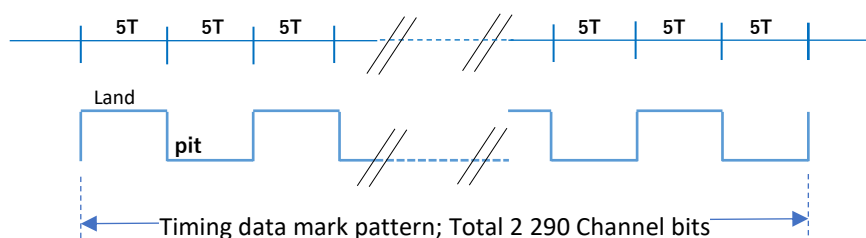

Figure 18 – Timing data mark pattern

### 12.2.6 Land field

Each Sector shall finish with a Land field with a length of 6 Channel bits.

## 12.3 Specific Disk Information (SDI)

### 12.3.1 General

The Specific Disk Information (SDI) shall be recorded in the SDI / timing data mark field of the Lead-in zone, as shown in Annex D.

### 12.3.2 SDI bytes encoding

The encoding of the SDI bytes shall be processed as shown in Figure 19. The encoded bits shall be represented by pits of the tracks.

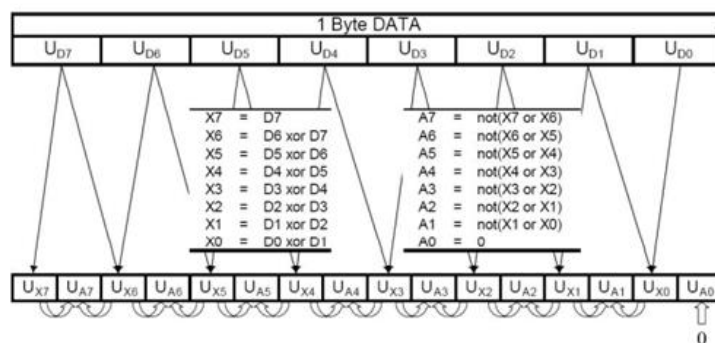

Figure 19 – SDI bytes encoding

## 12.4 Channel bits radial alignment

The misalignment  $\delta$  of the Channel bits of adjacent tracks shall be less than  $\pm 50$  nm, as defined in Figure 20.

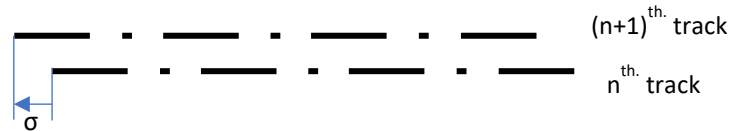

Figure 20 – Channel bits radial alignment

## 13 Data information format

### 13.1 General

The data information shall be stored in the form of holograms in the recording layer.

Each hologram contains a data page of information.

### 13.2 Data page holograms layout

#### 13.2.1 Hologram layout format

All hologram layout format characteristics shall be specified in reference to the track, as access to the information in the holographic recording layer is defined through the addressing features of the track. The hologram track address shall be in particular designated by the corresponding addressing data pits in the track.

Data page hologram layout is shown in Figure 21. Holograms are recorded by shift-multiplex recording[1], using interference of a signal beam and a spherical reference beam, moving in the track and radial directions. In addition, peristrophic multiplexing recording [2] is also performed using six different grating vectors. The overall data recording method is shown in Annex E.

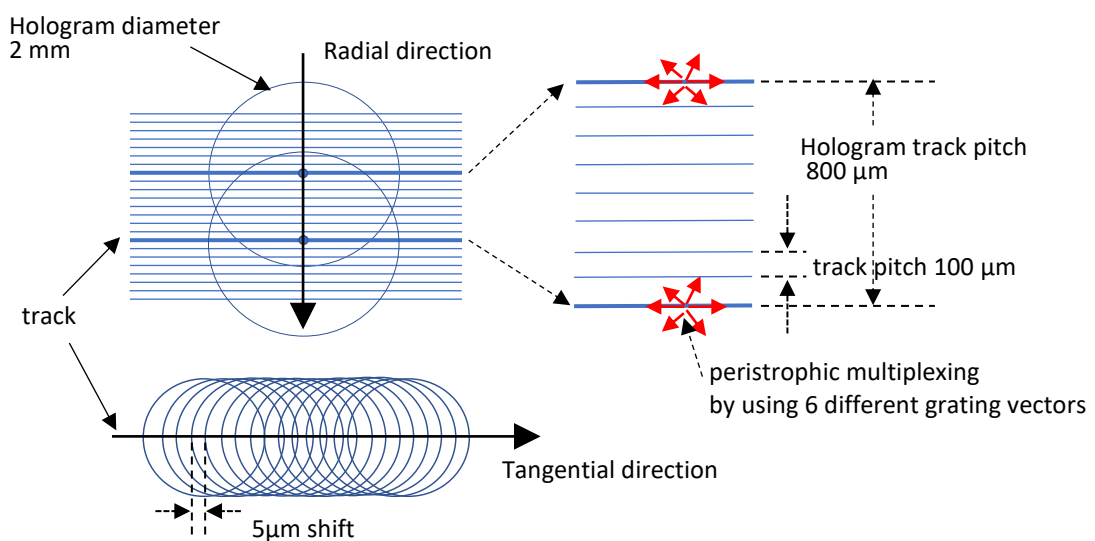

Figure 21 – Data page hologram layout

### 13.2.2 Data page holograms layout within tracks

This hologram recording is done by tangential shift-multiplex recording using one of six different grating vectors over the entire circumference of any one track. By repeating the recording six times, each time with a different grating vector, a six-multiplexed hologram is arranged as shown in Figure 21. After hologram recording is completed over the entire circumference of one track, the beam for recording is shifted in the radial direction and recording is performed in the same manner as above. This radial shift recording process is performed over the entire disk.

### 13.2.3 Radial data page hologram pitch

The radial data page hologram pitch shall be 8 track pitches.

### 13.2.4 Tangential data page hologram pitch

Holograms shall be recorded at a pitch of 5  $\mu\text{m}$  in the tangential direction of the disk, which corresponds to a hologram being recorded at every 10T position in the timing data mark field in a sector pre-recorded on a track, as shown in Figure 22. The first hologram position in the track shall synchronize with the transition timing from the sync pattern to the timing data mark pattern in the sector shown in Figure 22.

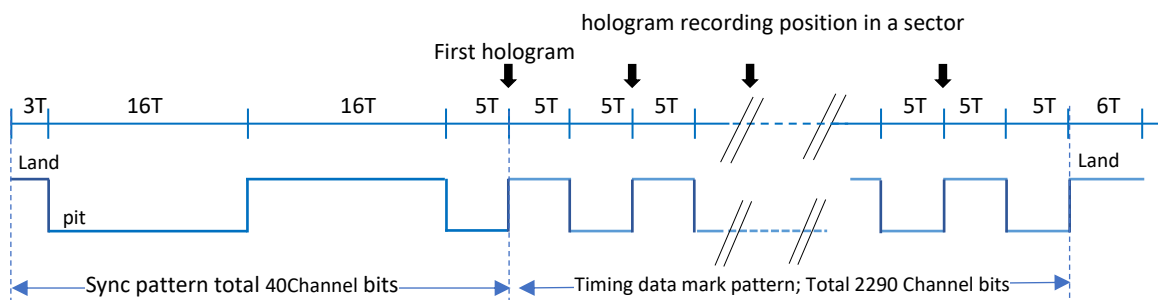

Figure 22 – First hologram recording position

## 13.3 Data page encoding

### 13.3.1 Encoding process

The 18 179 976 bytes of user data, consisting of 188 packets of 96 702 bytes, shall be processed as shown in Figure 23 to generate the contents of the hologram data page.

Each packet of 96 702 bytes is added a 28-byte header (see 13.2.2) and a 16-byte footer (see 13.2.3). These data are then encoded with inter page ECC (see 13.3.1). The inter-page ECC-processed data is followed by the addition of a 4-bit page number (see 13.4) and then encoded with intra-page ECC (see 13.3.2).



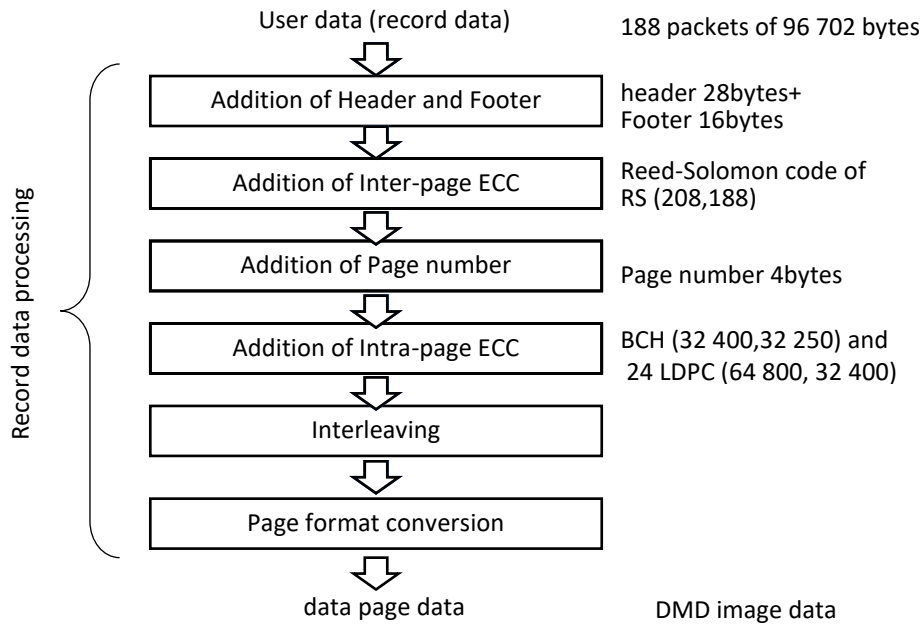
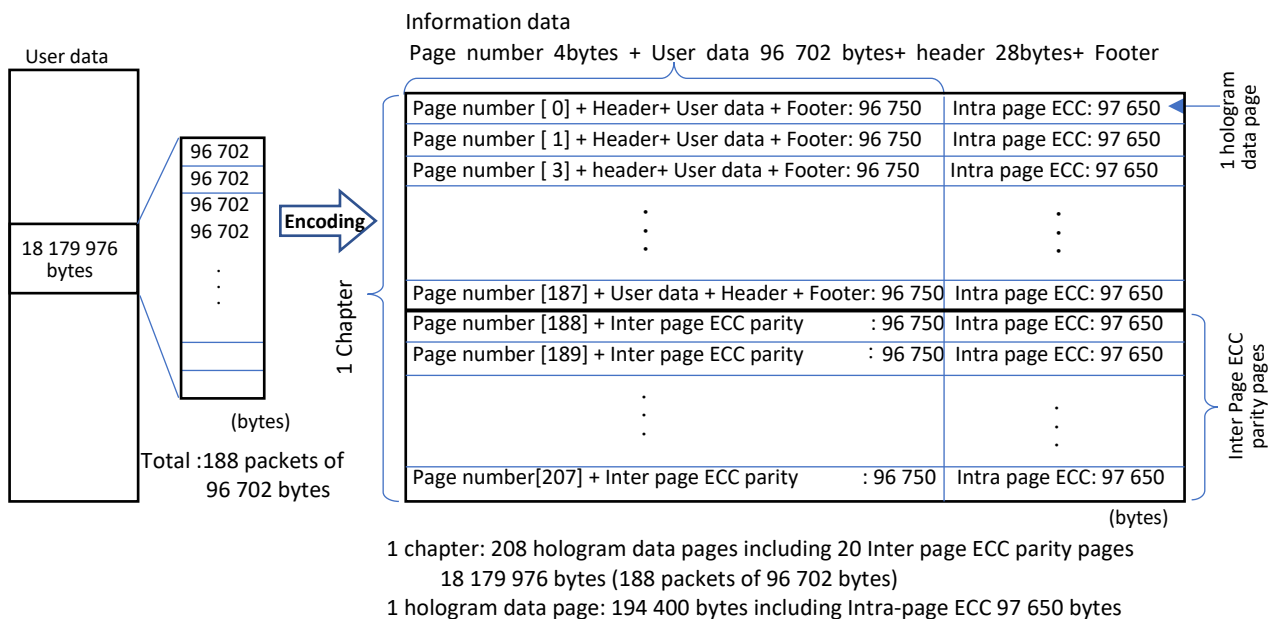

**Figure 23 – Record data encoding process**

Furthermore, after these encoding processes, interleaving shall be performed to deal with errors that may occur in the reproduced holograms due to media or sensor defects, and page format conversion is further processed to generate data page data (DMD image data) that is finally recorded on the disk as holograms.

Figure 24 shows the data format created by the encoding process of these series of user data as a chapter format. In this figure, one line of information data and intra-page ECC data are combined to form one hologram data page.

The 188 packets of user data are added with 20 packets of error correcting codes by the inter-page ECC process, resulting in a total of 208 packets.

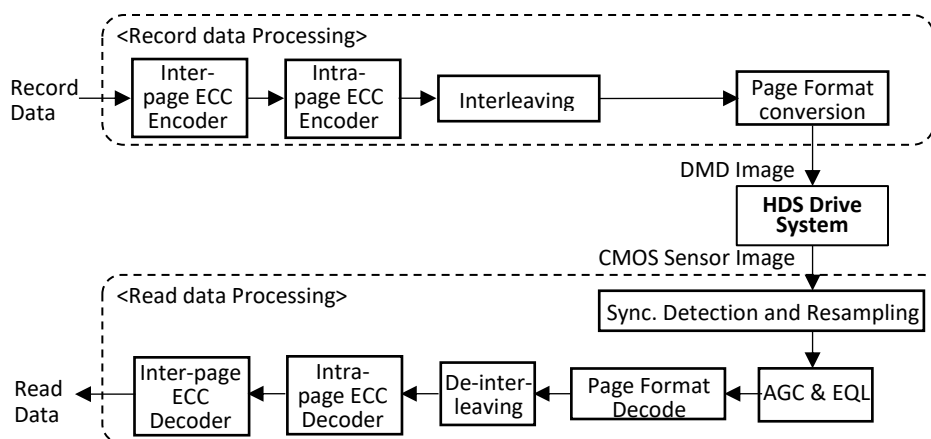

**Figure 24 – Chapter format**

Figure 25 shows the record signal processing and read signal processing after the inter page ECC.

In the recorded signal processing, the input data is encoded with BCH code and LDPC code and then interleaved. Furthermore, it is converted into a recording page format through page format conversion and recorded on a medium as a hologram.

At the time of reproduction, the recording page format is decoded after sync detection and resampling (see Annex F), automatic gain control (AGC), equalization (EQL) [3], and then deinterleaved. Finally, the LDPC code and BCH code are decoded, and the recorded data is extracted.



**Figure 25 – Record data processing and read data processing**

There is a possibility that the size of the data to be recorded is halfway, and data of only 0s continue on one page. In this case, the error correction capability of LDPC is degraded.

Therefore, as the pre-processing of recording data, the exclusive OR of the data to be recorded for one page and the repetition data of 0 and 1 is calculated and error correction coding is performed. After error correction during reproduction, the original recorded data is obtained by similarly calculating the exclusive OR with repeated data of 0 and 1 as the post-processing.

This process is intended to prevent consecutive 0s or 1s, and corresponds to a simplified version of a process called scrambling intended to randomize data.

### 13.3.2 Page header

Page header shall be 28 bytes added to each 96 702 user bytes packet (see Figure 24). These bytes are set to 0.

### 13.3.3 Page footer

Page footer shall be 16 bytes added to each 96 702 user bytes packet (see Figure 24). These bytes are set to 0.

### 13.3.4 Page number

Consecutive 4-byte page numbers shall be assigned to each of the 208 hologram data page packets.

Page numbers are incremented by one for each following page. The 208 packets of user data in the 2nd chapter are assigned page numbers from 208 to 417, the 208 packets of user data in the 3rd chapter are assigned page numbers from 418 to 625, and so on. The page numbers shall be incremented by 208 for each next chapter.

In addition, page number 0 (zero) is assigned to the data page data that is first recorded as hologram in the first track (r=22 mm) of the User data zone.

Figure 24 shows the assignment of page numbers from 0 to 207 to the 208 packets in the first chapter.

## 13.4 ECC

### 13.4.1 General

The ECC (Error Correction Code) byte is used by the error detection and correction system to correct erroneous data in the data page [4][5].

### 13.4.2 Inter-Page ECC

The 96 746 bytes of 188 user data packets constituted of Header + User data + Footer shall be processed by a Reed-Solomon code of RS (208,188), as described in Annex G, to generate 20 packets of 96 750 Inter-Page ECC bytes, as shown in Figure 24 which includes page number.

### 13.4.3 Intra-Page ECC

The 96 750 bytes of each of the above 208 packets shall be processed using BCH (32 400,32 250) and 24 LDPC (64 800, 32 400) to generate 97 650 Intra-Page ECC bytes that are added to each of these 96 750 bytes, as shown on Figure 24. Intra-Page ECC is described in Annex H [9].

### 13.4.4 Interleaving

Signals in certain areas of a page may be intensively degraded due to media or sensor defects or non-uniformity of the optical system. Even if the average error rate of the page is within the correctable range, if errors are concentrated in a part, the error correction capability may be exceeded, so interleaving is performed within the page to disperse the errors and make them correctable.

Interleaving shall be performed when the recording page is generated, and after the error correction coded data is arranged in order in the page, the order is rearranged using a random number. In deinterleave, the order is restored using the same random number as interleave before correcting the error in the read signal.

NOTE The random number should be determined by referring to [6]. the user must be informed of the Random number. Matlab function "randintrlv" and "randdeintrlv" are used to generate interleave table with initial state=4 831.

## 13.5 Data to image conversion

### 13.5.1 General

This clause describes the recording page format for data to image conversion on DMD.

This format does not use channel coding such as sparse code, but it is necessary to properly arrange each bit of user data in the page.

### 13.5.2 Recording page format

The 1 520 pixels x 1 520 pixels in the centre of the DMD described in Figure 4 is used to create the data page. Since optical systems such as lenses are designed based on a circular shape, it is desirable for the recording format to be as close to a circular shape as possible. Therefore, as shown in Figure 26, the top, bottom, left, and right corners are discarded as triangles, and an octagonal data page layout is set.

This data page shall be created by the following items: a symbol consisting of 4 pixels x 4 pixels (see 13.5.2), a sync pattern consisting of 16 pixels x 16 pixels (4 symbols x 4 symbols) (see 13.5.3), and a subpage consisting of 10 symbol x 10 symbols (see 13.5.4) with the sync pattern in the centre of the subpage.

As shown in Figure 26, the subpages are laid out in an octagon on the DMD.

In this data page format, 1 444 subpages are available for 1 520 pixels x 1 520 pixels. Since the triangles in the four corners are unused, if the discard width is 11 subpages, the unused portion of each triangle is 66 subpages.(Discarded subpage is 264 in total). In addition, to specify the page orientation of the hologram, the top left subpage is used as a Page sync where no data is recorded except sync pattern.

Then, the total number of usable subpages is 1 179 for data recording.

1 Hologram data page data (see Figure 25) and Sync patterns are raster-scan arranged in symbol units from the upper left corner to the lower right corner of the DMD usage area, with data page data with attribute number 20 and Sync patterns corresponding to each attribute number in sequence. In addition, each data is placed in symbols one byte at a time from top to bottom.

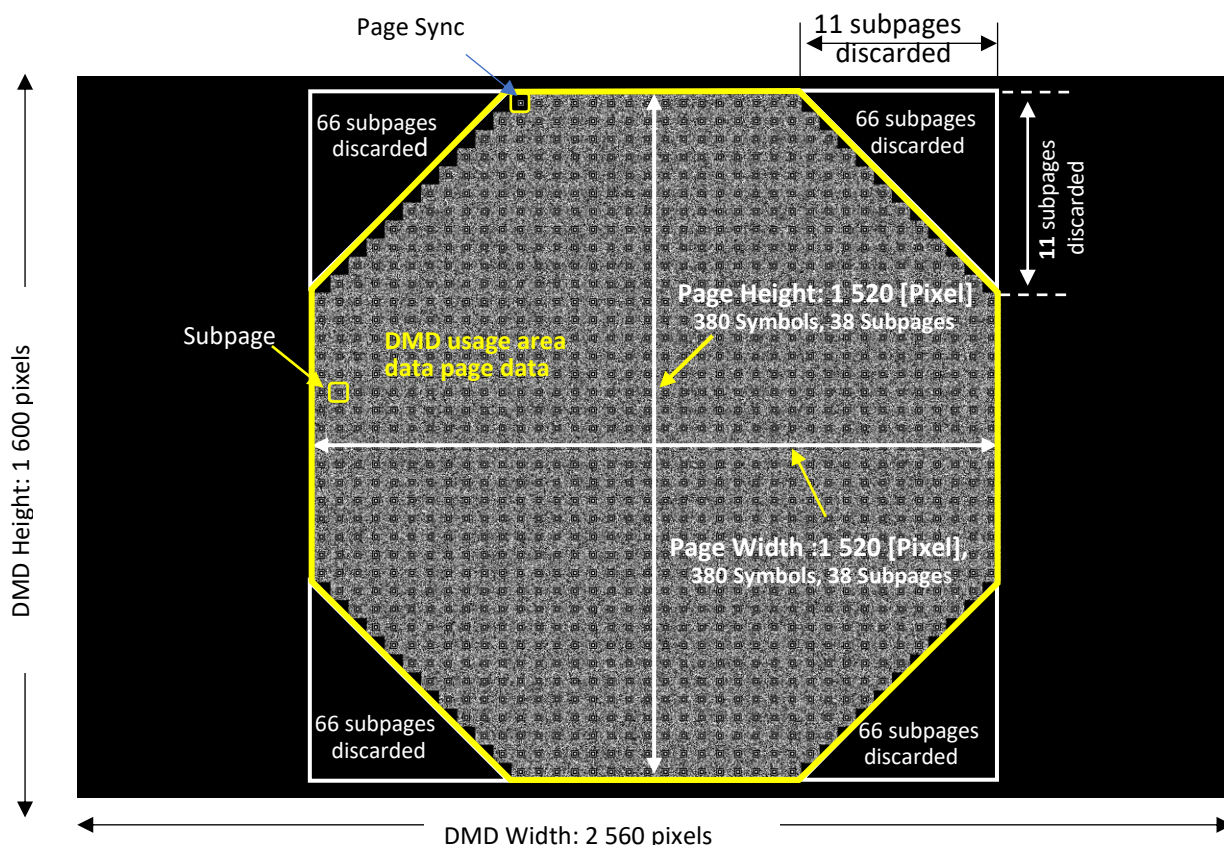

Figure 26 – Recording Page Format

### 13.5.3 Symbol

One symbol shall be made with 4 pixels x 4 pixels.

The 8 bits that make up one byte are configured into 4 pixels x 2 pixels, and the two pieces of one byte shall be arranged vertically to form one symbol of two bytes, as shown in Figure 27.

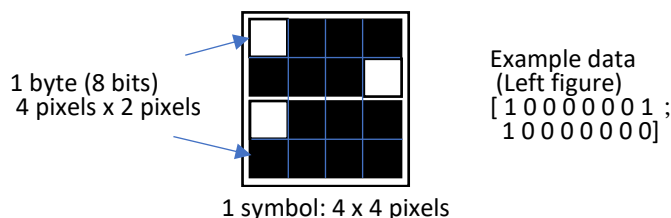

Figure 27 – Symbol Format

Each symbol shall be assigned a specific attribute number, such as attribute number 0, where no data is in place and all are "0"; attribute numbers 1 to 16 are symbols in which the 16 different sync patterns shown in 13.5.3 are assigned, attribute number 20 (any number other than 0 to 16) is the symbol under which the data page data is arranged.

### 13.5.4 Sync pattern

Since the recorded and or reproduced read signal page has noise, distortion, and misalignment, it is necessary to find a known sync pattern and resampling it to match each pixel recorded with each pixel of the read signal page.

In this format, 16 symbols shall be arranged in a 4x4 shape as shown in Figure 28(a) to form a total 256-pixel sync pattern. White is ON "1" and black is OFF "0". As shown in Figure 28(b), each symbol is given a different synchronization pattern with different 1-16 attribute numbers.

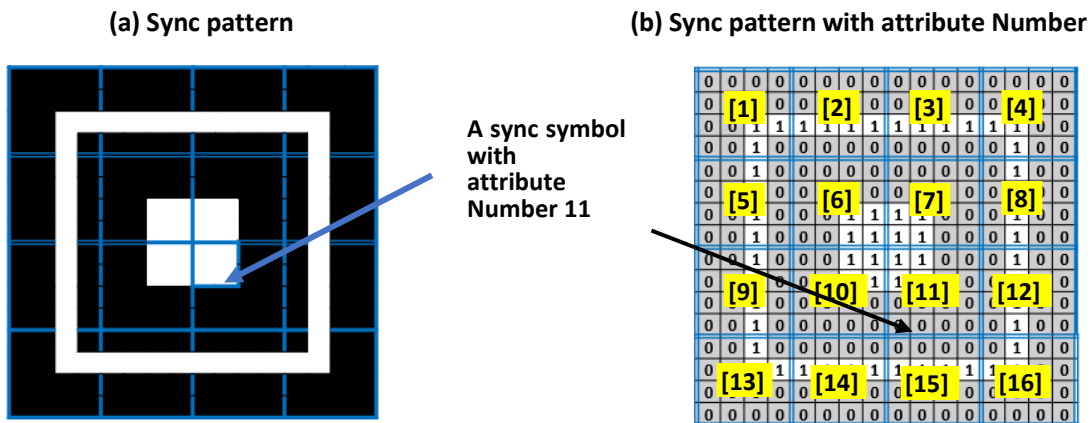

Figure 28 – Sync Pattern

### 13.5.5 Subpage and page sync pattern

The subpage shall be formed by 10 symbols x 10 symbols as shown in Figure 29(a). In the centre of the subpage consisting of this total of 100 symbols, a sync pattern with attribute numbers 1-16 shall be placed, and 84 symbols with attribute number 20 shall be placed around the sync pattern.

As shown in Figure 26, the page sync shall be placed in the upper left corner of the data page formed in an octagonal shape on the DMD. As shown in Figure 29(b), the page sync is a subpage consisting of a total of 100 symbols, with sync patterns with attribute numbers 1 to 16 placed in the centre, and 84 symbols with attribute number 0 placed around the sync patterns.

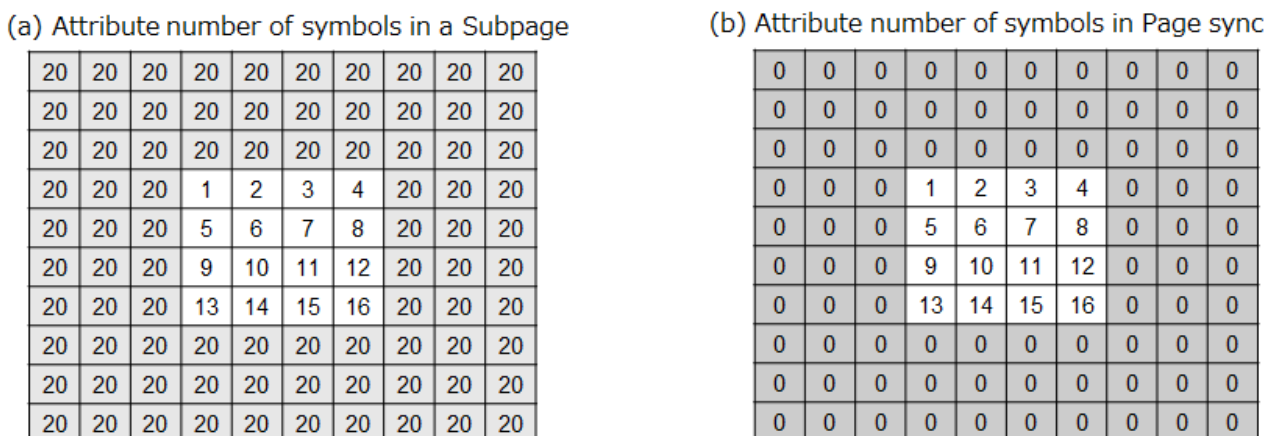

Figure 29 – Subpage and Page sync pattern

### 13.5.6 User data capacity of one page

As shown in 13.5.4, one subpage can record 84 symbols of data, so one page on the DMD can record 99 036 symbols (84 symbols per subpage x 1 179 subpage). Therefore, 198 072 bytes (1 584 576 bits) can be recorded in one page.

User data capacity in one disk is shown in Annex I.

## 14 Formatted zone

### 14.1 General

The Formatted zone contains all information on the disk relevant for data interchange. Using the track information recorded on the disk (information embedded as pits in advance in each track shown in Clause 12), the disk is divided into Lead-in zone, Test zone, User Data zone, and Lead-out zone from the inner to outer area of the disk.

### 14.2 Structure and usage of the formatted zone

#### 14.2.1 General

The Formatted zone shall be structured and used as shown in Table 5.

**Table 5 – Formatted zone**

| Zone numbers | Zone name      | usage                | Track address (Decimal) | Track radius (mm) | Number of tracks | Number of hologram tracks |
|--------------|----------------|----------------------|-------------------------|-------------------|------------------|---------------------------|
| 0            | Lead-in zone   | SDI                  | 0 to 3                  | 20 to 20,3        | 4                | 0                         |
|              | Test zone      | record and read test | 4 to 12                 | 20,4 to 21,2      | 9                | 2                         |
| 1            | User data zone | data record and read | 20 to 380               | 22 to 58,0        | 360              | 45                        |
| 2            | Lead-out zone  | Finalizing           | 381 to 390              | 58,1 to 59.0      | 10               | 1                         |

#### 14.2.2 Zone 0

The Zone 0 shall be divided in 2 Sub-zones, such as Lead-in zone and Test zone.

##### 14.2.2.1 Lead-in zone

The Lead-in zone shall be used for reading of SDI data shown in Annex D that is embedded in the Track in the form of pre-pit. The Lead-in zone is comprised of four tracks in the innermost area of the disk.

##### 14.2.2.2 Test zone

The Test zone shall be used for recording and reading tests prior to recording hologram data in the User data zone. The Test zone comprises 9 tracks.

#### 14.2.3 Zones 1 - User data zone

Zone 1 shall be used as the User data zone where user hologram data is recorded and read out.

The User data zone comprises 360 tracks.

The first user hologram data on the disk shall be recorded centred on Track 20.

#### **14.2.4 Zone 2 - Lead-out zone**

The Lead-out zone shall be used to record finalizing data. The Lead-out zone comprise 10 tracks.

### **15 Finalizing of disk**

Finalizing is the process of recording specific data designated by the user as hologram data, which indicates the completion of data recording to the disk in the Lead-out zone.

After finalizing, no further recording shall be permitted.

**NOTE** Since there are many spaces to record many holograms on one track in the Lead-out Zone, it is possible to record not only specific data for finalization, but also data that the user will refer to when archiving the data recorded on this disk, such as disk identification number, data name, data size, etc.

An example of user data recording format to be recorded together with finalization data is shown in Annex J.

### **16 Test condition for the signals from the tracking and focusing signal detection channel**

#### **16.1 General**

Tracking error  $I_{Tr}$ , focusing signal  $I_{Fc}$ , and address and SDI signal  $I_{sum}$  are obtained from a 4 split photodetector in the tracking and focusing signal detection channel of reference drive as shown in Figure 2. This clause provides the conditions for measuring the various test items considered in Clause 17 using the various signals obtained from the photodetectors.

#### **16.2 Environment**

All signals specified in Clause 9 shall be within their specified ranges in any environment in the range of allowed operating environments defined in 8.2.

#### **16.3 Test drive**

##### **16.3.1 General**

All signals specified shall be measured in the indicated channel of the reference drive specified in Clause 9. The drive has the following characteristics for the purpose of these tests.

##### **16.3.2 Optics and mechanics**

The drive shall have a tracking and focusing signal detection Channel, with the implementation as given in Figure 2. The tracking and focusing beam shall have the properties defined in 9.4.2. The disk rotates as specified in 10.2.

##### **16.3.3 Tracking requirements**

During the measurement of the signals, the focus of the tracking and focusing beam shall follow the pit track with the requirements of axial and radial deviation of tracking and focusing beam defined in 9.5.1.

## 16.4 Signals from 4 split photodetector

Figure 30 shows the current signals  $I_{sum}$ ,  $I_{SI}$ ,  $I_{Tr}$  and  $I_{Sh}$ , which are derived and processed from the outputs of the 4 split photodetector of the reference drive shown in Figure 2, and their current values are related to the light power incident on the detectors.

These current signals shall be the followings.

The sum signal  $I_{sum}$  from the 4 split photodetector is

$$I_{sum} = I_a + I_b + I_c + I_d$$

The track crossing signal  $I_{SI}$  is the low frequency signal of  $I_{sum}$  detected when the tracking and focusing beam crosses the track with the focus control system on.

The tracking error signal  $I_{Tr}$  is a low bandwidth subtraction signal.

$$I_{Tr} = (I_a + I_d) - (I_b + I_c)$$

Also, the  $I_{Sh}$  is the full bandwidth signal of  $I_{sum}$  read from the track with both tracking and focus control systems on.

The Figure 30(a) shows the  $I_{SI}$  and  $I_{Tr}$  signal from the SDI/ timing data mark field with focusing control on, and Figure 30(b) shows the  $I_{Sh}$  from track such as Address mark, Address data+ECC, Reserved field, Sync and timing data mark with the both focusing and tracking control on.

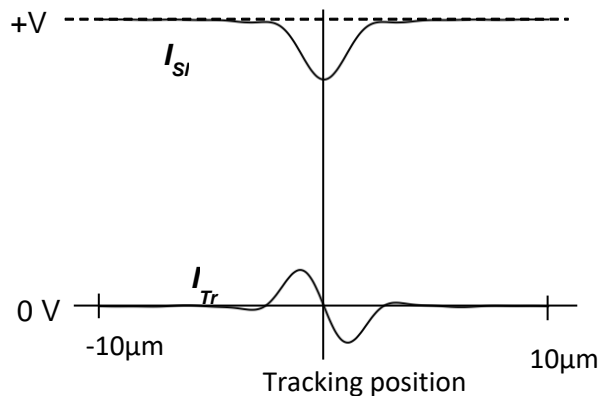

(a) Current signal  $I_{SI}$  and  $I_{Tr}$  from the SDI and timing data mark field

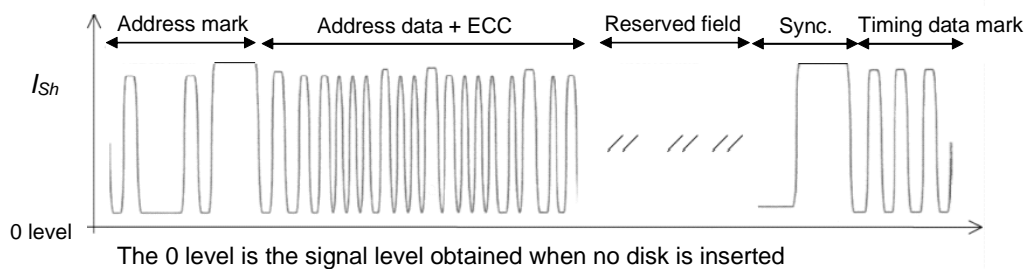

(b) Current signal  $I_{Sh}$  signal from Track

**Figure 30 – Current signal  $I_{sum}$  and  $I_{Tr}$  processed from the 4 split photodetector**



## 17 Requirement of the signals from tracking & focusing signal detection channel

### 17.1 General

This clause describes the requirement for the signals shown in Clause 16 , which are obtained from the tracking and focusing signal detection channel.

### 17.2 Reflectivity

The reflectivity is defined as the ratio of the upper level of signal  $I_{sum}$  obtained from a 5T land to the signal  $I_{sum}$  obtained from a totally reflecting disk. The reflectivity shall not be less than 18 %.

### 17.3 Normalized Push Pull signal

The push-pull signal is the sinusoidal difference signal  $I_{Tr}$  in the Radial tracking and focusing signal detection channel when the focus of the optical beam crosses the tracks. This signal can be used as error signal for radial tracking. The normalized peak-to-peak value of the push-pull signal  $I_{Tr}$  shall meet the following requirement in the Formatted Zone.

$$0,4 \leq \frac{(I_{Tr})_{PP}}{(I_{S'})_{av}} \leq 0,8$$

### 17.4 Modulation

The modulation of signal  $I_{sum}$  is the ratio of its average peak-to-peak value to its average top value.

$$\text{Modulation} = \frac{(I_{S'})_{PP}}{(I_{S'})_{top}}$$

The modulation shall not be less than 0,3 for the tracking data 5T marks.

### 17.5 Resolution

The resolution is the ratio of the average peak-to-peak value  $I_{2T}$  of the signal obtained from the shortest pit length 2T pits and 2T lands to the average peak-to-peak value of the signal  $I_{5T}$  obtained from pit length 5T pits from the Timing data mark field.

$I_{2T}$  is the shortest pit length in the address data or ECC data.

$$\text{Resolution} = \frac{I_{2T PP av}}{I_{5T PP av}}$$

The resolution  $I_{2T} / I_{5T}$  shall not be less than 0,5 for the address data or 2T pits in ECC field and 5T pits in the timing data mark field.

### 17.6 5T top signal fluctuation

The  $I_{5T top}$  is the upper envelope of the signal obtained from 5T pits pattern. The ratio of the peak-to-peak variation  $(I_{5T top})_{PP}$  and the maximum value  $(I_{5T top})_{max}$  is called the 5Ttop fluctuation.

$$5Ttop \text{ fluctuation} = \frac{(I_{5T top})_{PP}}{(I_{5T top})_{max}}$$

The 5T top fluctuation shall be less than 10 % on a disk revolution.

## 17.7 Jitter

Jitter is the standard deviation (sigma) of the time variation of the digitized data. The jitter of the 5T pits and lands, measured as a percentage of the nominal pits and lands durations, shall be less than 8 %.

## 17.8 Phase depth

The phase depth of pits shall be less than 90°

$$\text{Phase depth} = \frac{n \times d}{\lambda_T} \times 360^\circ$$

where  $n$  is the index of refraction of the cover layer,  $d$  is the pit depth, and  $\lambda_T$  is the wavelength of the tracking and focusing beam.

# 18 Data recording test condition and recording characteristics requirement

## 18.1 General

This clause describes test condition and requirements for evaluating data recording characteristics.

## 18.2 Environment

The requirement of media testing shall be obtained in any environment in the range of allowed operating environments defined in 8.2.

## 18.3 Test drive

### 18.3.1 General

The record tests shall be measured in the hologram recording and reading channel of the reference drive. The drive shall have the following characteristics for the purpose of these tests.

### 18.3.2 Optics and mechanics

T hologram recording and reading channel and a tracking and focusing signal detection channel as given in 9.2. The disk shall rotate as specified in 10.2.

### 18.3.3 Data recording pules energy

The data recording pules energies of recording beam shall be as specified in the SDI (see Annex D).

### 18.3.4 Data reading pules energy

The data reading pules energy shall be as specified in the SDI (see Annex D).

### 18.3.5 Tracking requirements

During the measurement of the signals, the focus of the tacking and focusing beam shall follow the pit track with the requirements defined in 9.5.1.

### **18.3.6 Relative position of the focus of the data recoding beam and the tracking and focusing beam**

The relative positions of the focus of the recoding beam (signal beam and reference beam) and tracking beam during data recording are defined in 9.5.2.

## **18.4 Recording conditions**

### **18.4.1 Recording pulse energy**

Hologram data pages are recorded on the disk by recoding pulses energy at the test rotational frequency. The measurement of recording pulses energy shall be done in pulsed operation by averaging. The averaging method of measuring the laser power will minimize the accumulation of pulse width and pulse amplitude tolerances.

### **18.4.2 Recording pulse energy determination**

The reference drive shall read the recording pulse energy level parameter embedded in the track format as SDI data specified by the manufacturer at the time of disk manufacturing, and generate hologram recording data that complies with the requirements of Clause 19.

## **18.5 Recording characteristics requirement**

The recording characteristics shall have the performance to be able to properly record and read out data under the conditions compliant with Clause 9, and the record data page shall not contain errors in bytes that cannot be corrected by the error correction circuit when reading out page data.

Recorded data shall not be damaged by repeated reading of the hologram page. Disk shall be tested against damage from reading energy. No error shall appear after ECC decoding after 1 million readouts.

## **19 Recorded user data reading test conditions and requirement**

### **19.1 General**

Clause 19 defines the measurement conditions for testing the conformance of user data on the disk to this standard and the minimum data quality required for data exchange.

NOTE Recorded user data shall be voluntary and may be recorded by any drive in any environment.

### **19.2 Environment**

The quality of recorded user data shall be verified in any environment in the range of allowed operating environments defined in 8.2.

### **19.3 Test drive**

#### **19.3.1 General**

The quality of recorded user data shall be measured by the reference drive specified in Section 9.

The drive shall have the following characteristics for the purpose of these tests.

#### **19.3.2 Optics and mechanics**

The reference drive shall have hologram recording and reading channel and a tracking and focusing signal detection channel as given in 9.2. The disk rotates as specified in 10.2.

### **19.3.3 Data reading pulses energy**

The data reading pulses energy shall be as specified in the SDI specified in Annex D.

### **19.3.4 Tracking requirements**

During the measurement of the signals, the focus of the tracking and focusing beam shall follow the pit track with the requirements defined in 9.5.1.

### **19.3.5 Relative positioning of the focus of the data reading beam and the tracking and focusing beam**

The relative positions of the focus of the reading beam and tracking beam during data reading are defined in 9.5.3.

## **19.4 Data page quality minimum requirement**

A byte error detected by ECC system occurs when one or more bits in a byte have a wrong setting. The hologram regeneration power energy on the CMOS image sensor surface shall be set to be greater than 5 pJ in order to keep the raw error rate, including random and burst errors, below 10 %.

## **20 Data interchange requirements**

### **20.1 General**

A disk offered for interchange of data shall comply with the following requirements.

### **20.2 Tracking**

The focus of the optical beam shall not jump tracks unintentionally.

### **20.3 User-written data**

Data for interchange shall be written anywhere within the User data zone.

### **20.4 User-read data**

Any recorded data in a data page shall not contain any byte errors after error correction during read out.

## Annex A (informative)

### Pre-cure, post-cure method

The pre-cure and post-cure process of an area of the disk is done by illumination of LED shown in Figure A.1, the wavelength of which is  $405\text{ nm} \pm 1\text{ nm}$ . The scheme shown in this figure is an example. Pre-cure and post-cure are performed on the entire disk surface by multiple LEDs. A plurality of LEDs is arranged in proportion to the radius on the inner and outer circumferences. The illumination energy is maximum 1 Jule for pre-curing and maximum 3 Jule for post-curing. Pre-cure is carried out just before the data recording and post-cure is done after completion of multiplexed recording. Both processes are carried out at the all Formatted Zone excluding Lead-in zone.

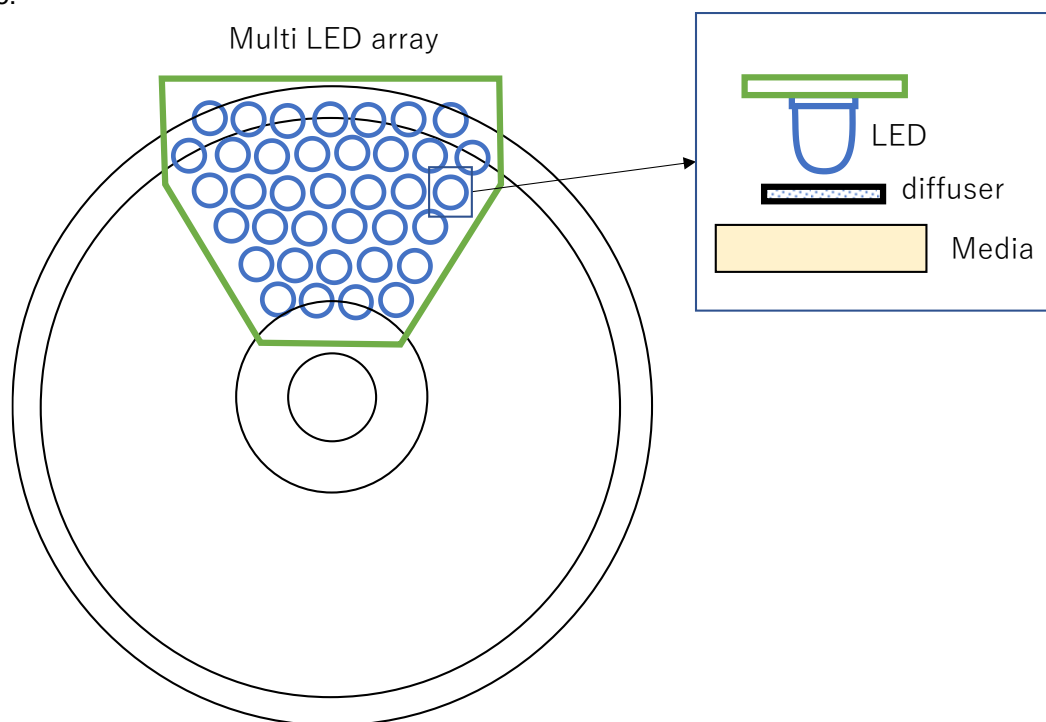

Figure A.1 – Pre-cure and post-cure method



## Annex B (informative)

### Influence of birefringence measurement

Measuring device setup (shown in Figure B.1)

- A collimated linearly polarized laser beam with a wavelength of 405 nm and beam diameter of 2 mm  $\phi$  (polarization ratio of 10:1 or more) is placed on the entrance side of the test sample disk. A polarizing beam splitter PBS (extinguishing ratio of about 50:1) and two photodetectors PD1 and PD2 are placed behind the test sample disk. The PBS is arranged so that the output  $I_p$  of PD1 is the minimum and the output  $I_s$  of PD2 is the maximum with respect to the incident S polarization when there is no test sample.
- In the test sample disk, the direction parallel to the S polarization is arranged as X axis. The direction parallel to the P polarization is arranged as Y axis, and the direction along the optical axis of the laser beam is arranged as the Z axis. The test sample disk can be moved all over the XY plane and allows the rotation  $\theta_x$  around the X axis and rotation  $\theta_z$  around the Z axis.

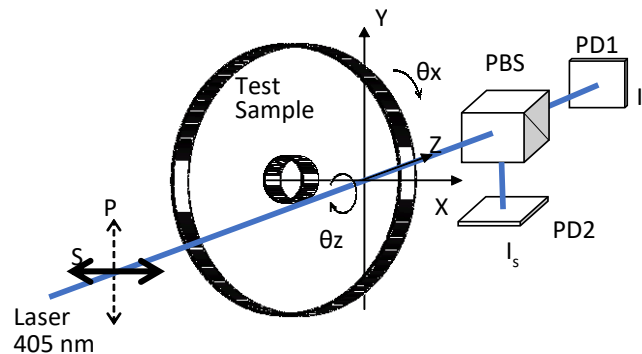

**Figure B.1 – Measuring device setup**

Measuring method (shown in Figure B.2)

- The polarization ratio  $R(\theta_x, \theta_z)$  is measured by the following procedure.
  - 1) Set the test sample disk in the XY plane.
  - 2) In the rotation  $\theta_x$  around the X axis, measure the output  $I_p$  and  $I_s$  of the photodetectors PD1 and PD2 while changing the rotation  $\theta_z$  around Z axis from 0 degree to 180 degree.
  - 3) Obtain the polarization ratio  $R(\theta_x, \theta_z)$  is
 
$$R(\theta_x, \theta_z) = I_s / (I_s + I_p).$$
  - 4) Let  $R(\theta_x, \theta_z)$ , which is the minimum for all  $\theta_z$ , be  $R_{min}(\theta_x)$ .

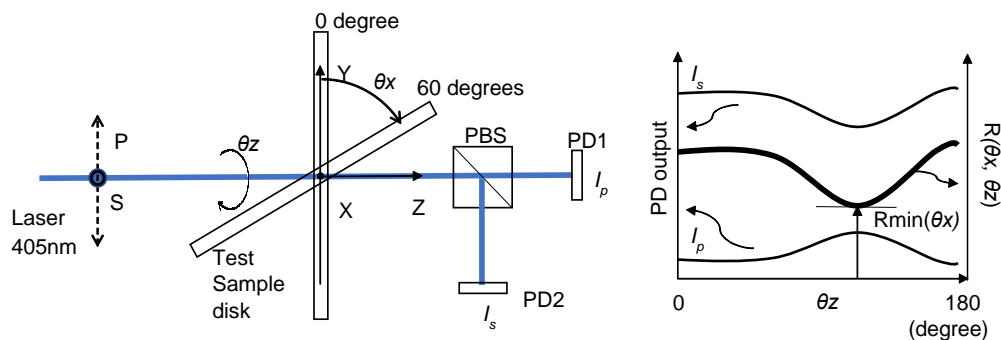

**Figure B.2 – Measuring method**





## Annex C (informative)

### Case for holographic data storage disk

The case is a protective enclosure for a disk. On both sides of the case have access windows covered by shutters. Through the access windows, the drive spindle clamps the disk through the centre hole, and the optics for recording and reading holograms access the disk. This window is automatically shuttered open by the drive when the case is inserted into the drive, and the window is automatically shuttered closed when the case is removed from the drive.

#### C.1 Environmental conditions

##### (1) Operating environment

|                         |   |
|-------------------------|---|
| Temperature             | 30°C to 40°C                                |
| Atmospheric pressure    | 60 kPa <sub>a</sub> to 106 kPa <sub>a</sub> |
| Relative humidity       | 20 % to 80 %                                |
| Absolute humidity       | 25 g/m <sup>3</sup> max                     |
| Ambient light           |   |
| shutter close           | 925 lx, (135 μW/cm <sup>2</sup> )           |
| shutter open (in drive) | 0,007 lx, (1 nW/cm <sup>2</sup> )           |
| Air cleanliness         | office environment                          |

##### (2) Storage environment

|                               |                                  |
|-------------------------------|----------------------------------|
| Temperature                   | 16°C to 32 °C                    |
| Atmospheric pressure          | 60 kPa to 106 kPa                |
| Relative humidity             | 20 % to 40 %                     |
| Absolute humidity             | 25 g/m <sup>3</sup> max.         |
| Ambient light (shutter close) | 925 lx (135 μW/cm <sup>2</sup> ) |
| Air cleanliness               | Office environment               |

#### C.2 Temperature shock

The case shall withstand a temperature shock of up to 10°C when inserted into, or removed from the drive. No condensation on the case occurs.



## Annex D (normative)

### Specific Disk Information

Disk Specific Information (SDI) is information that is pre-recorded in the form of pits on the four tracks of the innermost Lead-in zone of a disk by the disk manufacturer, which are the optimum data recording conditions such as recording and reading laser wavelength and laser power to the disk, etc., and data requested by the user.

In order for the user to properly record data onto a disk, the drive shall first access the tracks in this Lead-in zone, read the SDI, adjust and set the drive's recording parameters based on the SDI, and start recording the user data.

Table D.1 shows-items that shall be recorded as SDI at least and the format of the arrangement of the SDI data on the track.

Although this table specifies the data size of each item and its recording position, these are determined upon consultation between the user and the disk manufacturer, along with any additional items, sizes, etc., based on the user's requirements.

**Table D.1 – SDI information**

| Track number |      | Sector number |      | Data recording start channel bit                                     |              | Items                    |
|--------------|------|---------------|------|--|--------------|--------------------------|
| DEC          | HEX  | DEC           | HEX  | DEC  | HEX          |                          |
| 0            | 0000 | 0             | 0000 | 224  | 00E0         | Disk ID                  |
|              |      |               |      | 352  | 0160         | Record & Read wavelength |
|              |      |               |      | 384  | 0180         | Recording pulses energy  |
|              |      |               |      | 416  | 01A0         | Reading pulse energy     |
|              |      |               |      | 448  | 01C0         | Pre-cure energy          |
|              |      |               |      | 480  | 01E0         | Post-cure energy         |
|              |      |               |      | 512 to 2,290   | 0200 to 08F0 | Reserved                 |
| 1            | 0001 | 0             | 0000 | Repeat of the above item data recording to channel bits 224 to 2,290 |              |                          |
| 2            | 0002 | 0             | 0000 | Repeat of the above item data recording to channel bits 224 to 2,290 |              |                          |
| 3            | 0003 | 0             | 0000 | Repeat of the above item data recording to channel bits 224 to 2,290 |              |                          |



## Annex E (normative)

### Disk multiplex recording method

Holograms are recorded by shift multiple recording[1] and peristrophic multiplexing recording[2] using the recording beam as shown in Figure E.1. Shift-multiplex recording is performed by moving the recording beam with a pitch of  $5\ \mu\text{m}$  in the tangential direction and a pitch of  $800\ \mu\text{m}$  in the radial direction and peristrophic multiple recording is performed by changing the angle of the grating vector of the recording beam in six different ways in each hologram recording track.

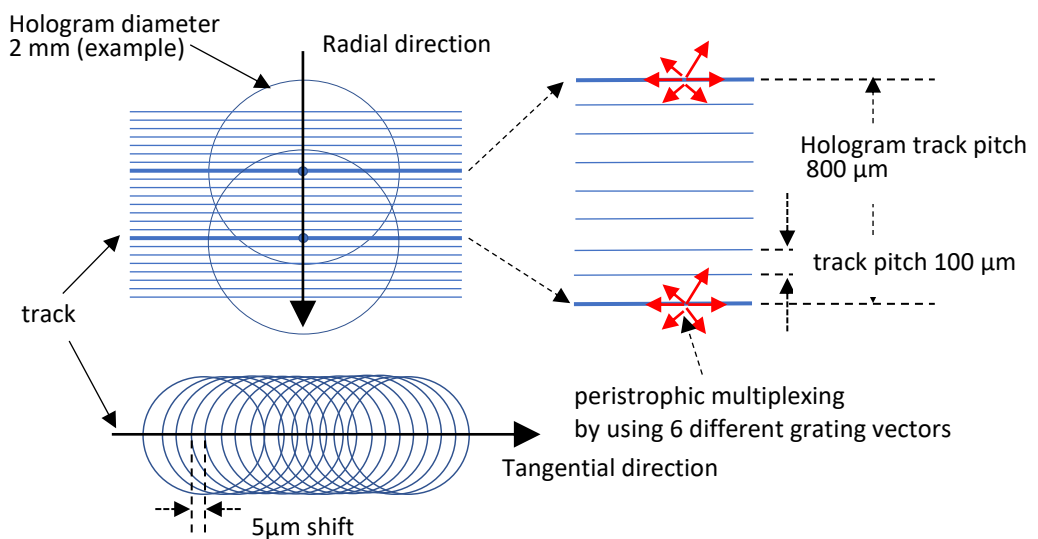

**Figure E.1 – Recording method**

Grating vector (GV) angle is determined by considering shift selectivity in shift-multiplex recording and crosstalk during multiplex recording. The angles of the GV shall be 0, 30, 150, 180, 210, and 330 degrees counter clockwise with the angle in the tangential direction being 0 degree shown in Figure E.2.

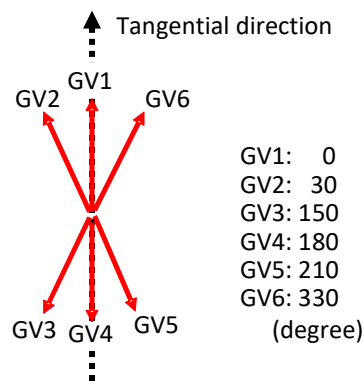

**Figure E.2 – Grating vector**

Figure E.3 shows the position of the grating vector from the innermost circumference to the outermost circumference of the disk. Track number 0 to 12 are Lead-in zone, which include SDI zone and data recording

and reading test zone. Track numbers 4 to 12 are a record and read test zone. Track number 381 to 390 are the Lead-out zone. Track numbers 20 to 380 are user data zone.

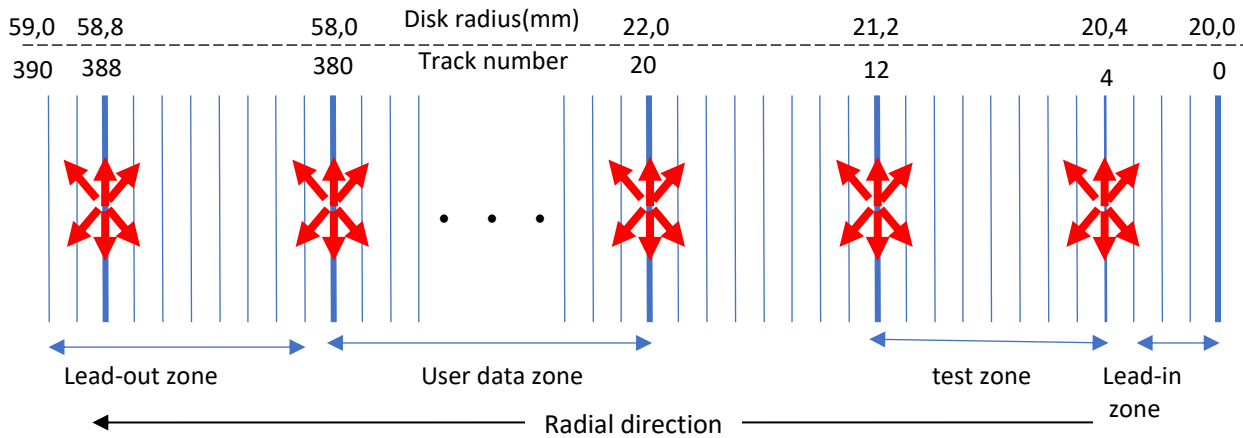

**Figure E.3 – Grating vector position in one disk**

The timing of GV changes during user data recording is determined by the User's recording strategy. As an example, the entire disk is recorded with one of six different GVs (5- $\mu$ m shift-multiplex recording in the tangential direction on one track and 8-track shift recording in the radial direction on the entire disk in sequence), then user data is recorded on the entire disk in the same way using a different GV, and this is repeated six times.

Methods for changing the GV include a moving the position of the recording disk relative to the recording head, rotating the signal optical system around the reference optical system, and so on. An example of the former recording method is shown in Figure E.4.

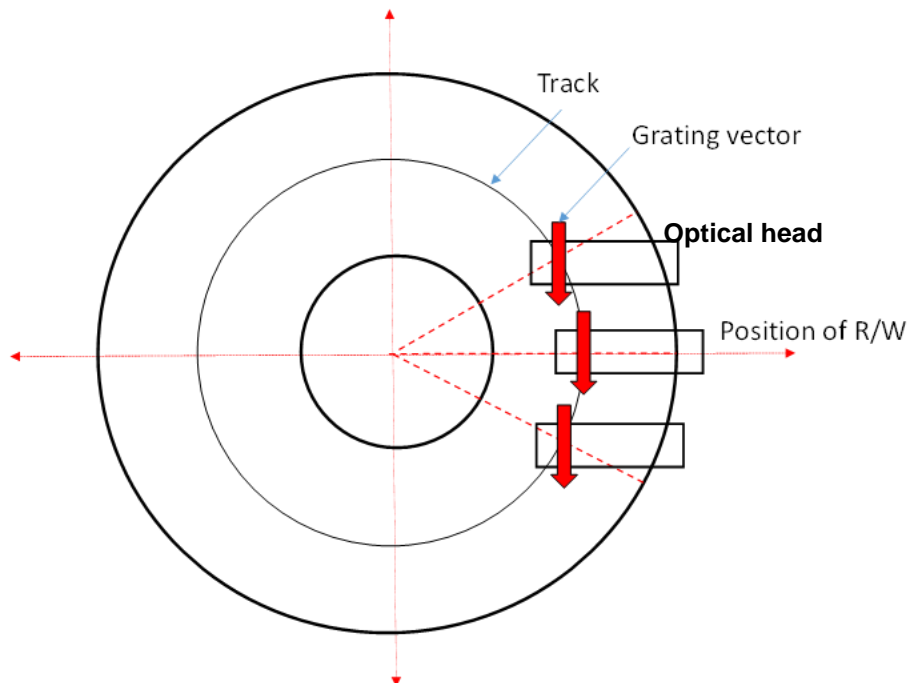

**Figure E.4 – Changing of grating vector method (example)**

## Annex F (informative)

### Sync detection and resampling

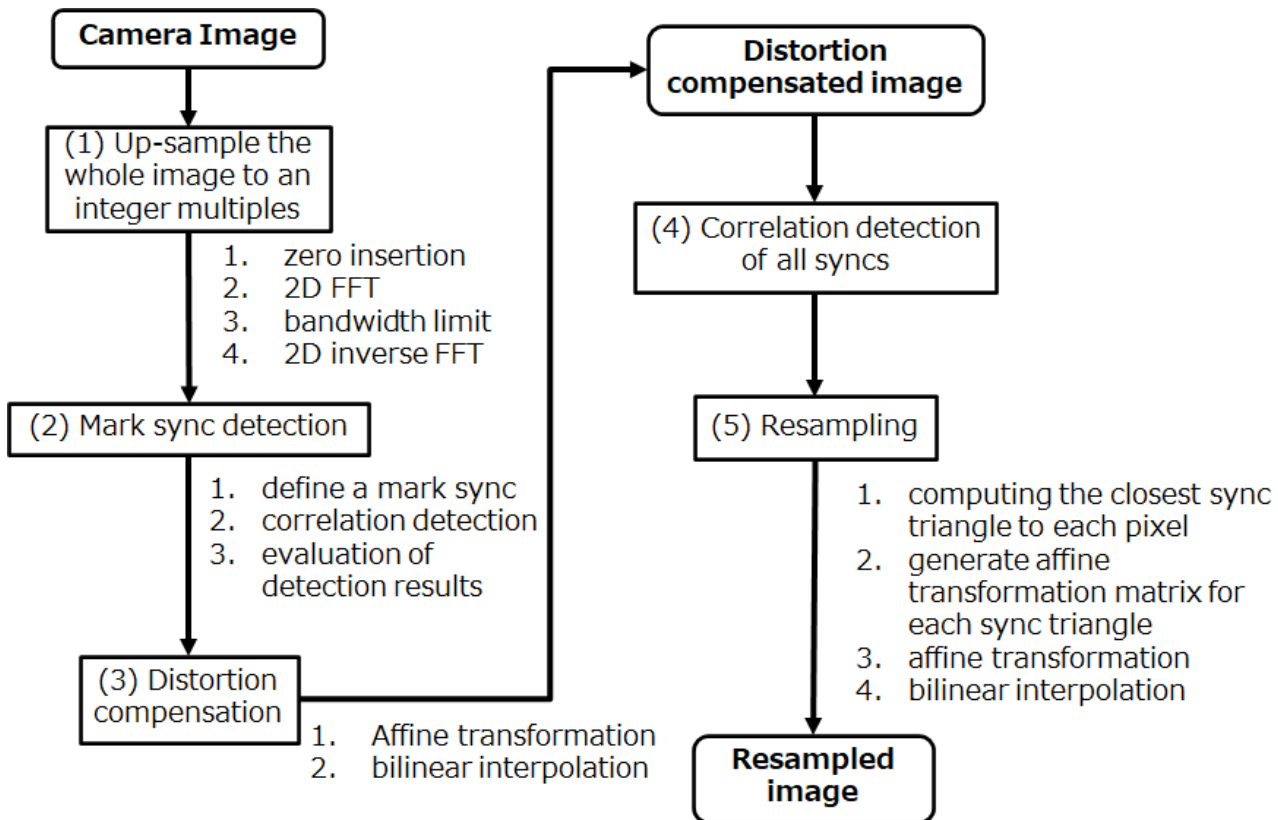

**Figure.F.1 – Sync detection and resampling**

The synchronous detection and resampling procedure shown in Figure F.1 is briefly explained.

**(1) Up-sample the whole image to an integer multiple**

Here, the image acquired by the camera is assumed to be 1.5 x 1.5 oversampled and first up sampled to integer multiples (for example 3 x 3, 6 x 6) to simplify the correlation calculation for sync detection. This is done by the following steps, Zero insertion, 2-dimensional FFT, Bandwidth limitation, and 2-dimensional inverse FFT.

**(2) Mark sync detection**

If all syncs are searched and detected in a wide range, the calculation time becomes very long (the circuit scale becomes large). Therefore, mark syncs are defined in advance at the centre of the diagonal line and intermediate positions on the top, bottom, left, and right, and only these are detected in a wide range.

Extract the neighbourhood of the five-mark syncs in the integer-up sampled camera-acquired image. A correlation between these and a known sync pattern are calculated to detect the position of the mark sync.

In this case too, searching a wide range from the beginning takes a lot of calculation time, so narrow range is searched at first, the correlation peaks found are evaluated, and only the disqualified ones are recalculated by widening the search range.

(3) Distortion compensation

Once the five-mark syncs are successfully detected, the deviation from the original position is checked and the distortion is corrected by a combination of affine transformation and bilinear interpolation.

(4) Correlation detection of all syncs

This distortion-corrected image is used to detect all syncs. As in the case of mark syncs, the neighbourhood of each sync in the camera-acquired image is extracted and correlation detection is performed.

(5) Resampling

After detecting the position of all syncs, resampling is performed.

Since triangles before and after mapping are required for affine transformation, a number of sync triangles composed of three adjacent syncs are created, and the closest sync triangle to each pixel is calculated. The positional relationship between each pixel and each sync is determined by the recording format, so this calculation only needs to be done once at the beginning.

Then, according to the position of each detected sync, calculate the affine transformation matrix for each sync triangle, use it to perform the affine transformation of each pixel position, and calculate the amplitude of each pixel position by bilinear interpolation.

At this point, the resampling is completed, and a reproduced image is obtained that has pixels in one-to-one correspondence with the recorded pixels.



## Annex G (informative)

### Inter-Page ECC

As shown in Figure H.1, 96 746 bytes are recorded with Header + User data + Footer on one hologram page. 188 ( $k=0\sim 187$ ) pages of packets are grouped together and divided into byte units.

Collect 188 packets of  $n^{\text{th}}$  byte ( $n=0\sim 96\,745$ ) of pages, and perform ECC encoding of RS (208,188), a shortened of RS (255,235), to generate 20 parity packets. 96 746 bytes of the  $k^{\text{th}}$  packets ( $k=188\sim 207$ ) of parity are put together to form one parity page, and 20 parity pages are generated.

Since the error correction capability of this inter-page ECC is half of the 20 parity pages, 188 pages containing user data can be corrected even if up to 10 of the 208 pages are missing.

NOTE RS(208,188) of GF(28) is used for Inter Page ECC with Primitive polynomial =  $D^8+D^4+D^3+D^2+1$ .

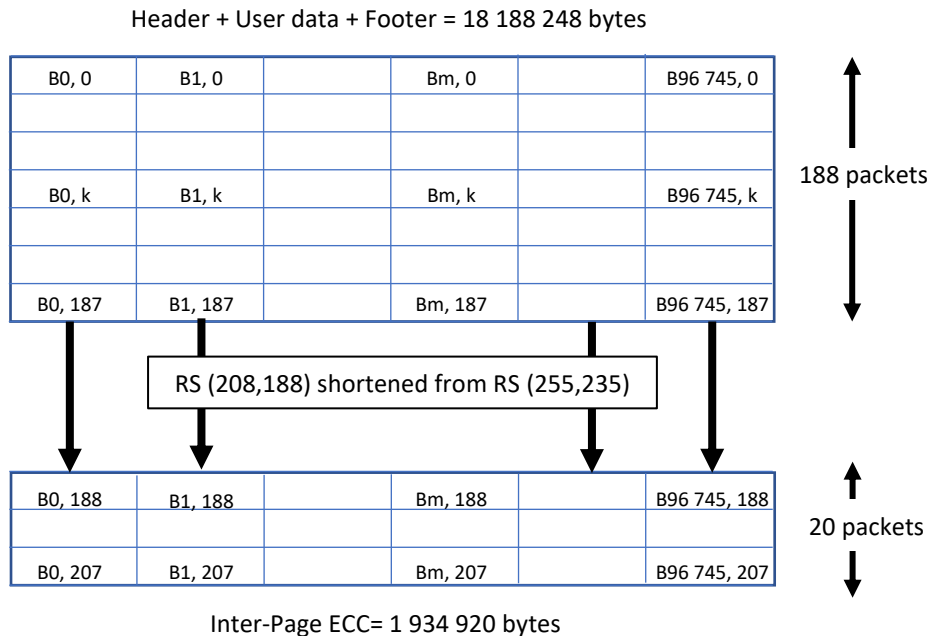

**Figure G.1 – Inter-Page ECC**



## Annex H (informative)

### Intra-Page ECC

As shown in Figure H.1, the information data (Page Number + Header + User data + Footer) recorded on one hologram page is 96 750 bytes. BCH (32 400, 32 250) error corrections is used as the outer code. After encoded as the inner code, 24 LDPC (64 800, 32 400) code words are recorded in one hologram page [9].

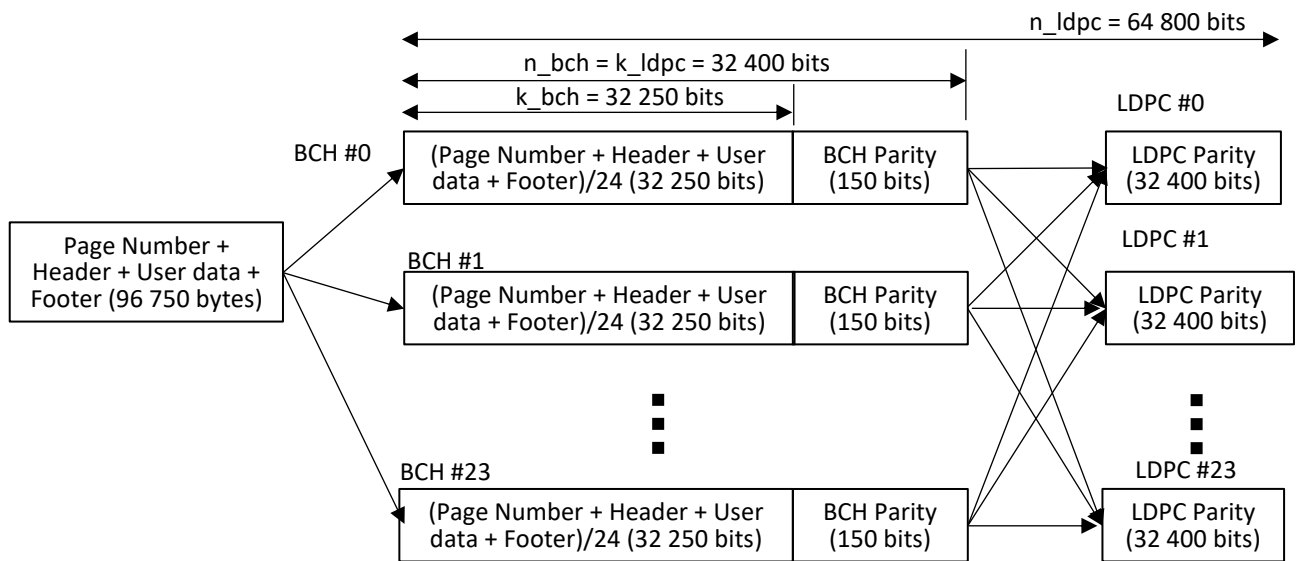

**Figure H.1 – Intra-Page ECC**

BCH (32 400, 32 250) is a shortened code of BCH (32 767, 32 617) with 10 error correction. If errors that cannot be corrected by the LDPC code remain, and 10 or more errors are concentrated in one codeword, the BCH code cannot correct them.

Therefore, as shown in Figure H.2, the concept of product code is applied for error correction coding. Assuming that the number of information bits is 32 250 and the number of code words is 24, the information bits for one page before BCH coding are 774 000 (32 250 x 24) bits. Next, the 774 000 (32 250 x 24) bits are encoded in BCH (32 400, 32 250) to create a two-dimensional array of (32 400, 24).

This two-dimensional array of 777 600 bits is then created as a one-dimensional vector (32 400 x 24,1) in sequence, and reshaped into (24, 32400). Perform LDPC (64 800, 32 400) coding with a codeword length of 64800 bits for each reshaped 32 400 bits to create a 2-dimensional array of (24, 64 800).

By doing so, errors that could not be corrected by the LDPC code are distributed to the 24 BCH code, and the error correction capability of the BCH code can be improved.

NOTE Matlab function "dvbs2ldpc" is used with rate=0.5 to generate Parity check matrix.

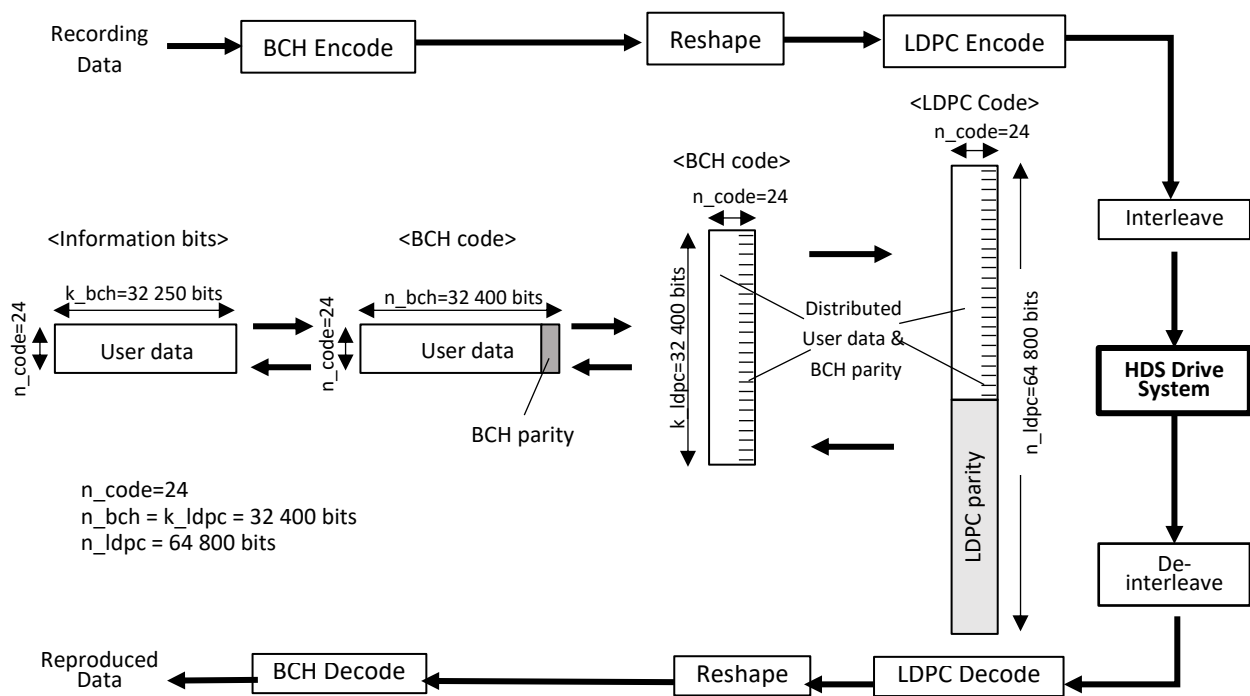

Figure H.2 – Configuration of Intra-Page ECC

## Annex I (informative)

### User capacity in one disk

The hologram recording area for user data is between radius 22.0 mm and 58.0 mm. In this range there is a track every 100  $\mu\text{m}$ , so there are 360 tracks in total.

In this system, the recording is shifted every 800  $\mu\text{m}$ , so the hologram is recorded on 45 of the 360 tracks in total. The number of sectors with holograms recorded on these 45 tracks from 22 mm to 58.0 mm radius is to be calculated 9 154.

As explained in Table1, one sector has 2 290 bits for determining the recording position. Holograms are recorded every 10 bits. Therefore, there is a position where 229 holograms are recorded in one sector. As shown in Figure 21, The 6 multiple holograms are recorded at different angles, so 1 374 holograms (229 sectors x 6 multiplex) are recorded in one sector.

Since there are 9 154 sectors in which holograms for user data are recorded on one disk, 12 577 596 holograms (1 374 holograms x 9 154 sectors) are recorded.

Since the chapter consists of 208 holograms (pages), 60 469 chapters are recorded on one disk.

As shown in Figure 24, One chapter contains 18 179 976 bytes of user data (188 packet of 96 702 bytes), so 1,099 Tbyte is the user capacity of one disk.



## Annex J (normative)

### Finalizing data

Finalizing data is recorded as a hologram on a single track in the Lead-out zone.

Table J.1 shows the format in which finalized data and examples of data desired by the user are recorded on the track.

The finalizing data shall be easily recognizable as end of data recording when the drive reads the data in the Lead-out zone. All data shall be "1".

Finalizing data shall be recorded using GV1, i.e., the angle of 0 degree in the tangential direction.

**Table J.1 – Finalizing data**

| Track number |      | Sector number |      | Data recording start channel bit |      | Items  |
|--------------|------|---------------|------|----------------------------------|------|--|
| DEC          | HEX  | DEC           | HEX  | DEC                              | HEX  |  |
| 388          | 0184 | 0             | 0000 | 224                              | 00E0 | Finalizing Data                                |
| 388          | 0184 | 2             | 0002 | 224                              | 00E0 | Disk ID  |
|              |      |               |      |                                  |      | Record & Read wavelength                       |
|              |      |               |      |                                  |      | Recording pulse energy                         |
|              |      |               |      |                                  |      | Pre-cure energy                                |
|              |      |               |      |                                  |      | Post-cure energy                               |
|              |      |               |      |                                  |      | Tangential shift length                        |
|              |      |               |      |                                  |      | Radial shift length                            |
|              |      |               |      |                                  |      | Signal beam incident angle                     |
|              |      |               |      |                                  |      | Reference beam incident angle                  |
|              |      |               |      |                                  |      | End track of user data                         |
|              |      |               |      |                                  |      | End sector of user data                        |
|              |      |               |      |                                  |      | Temperature                                    |
|              |      | Reserved      |      |                                  |      |  |
| 388          | 0184 | 4             | 0004 | 224                              | 00E0 | Recording of one hologram recorded in 0 sector |
| 388          | 0184 | 6             | 0006 | 224                              | 00E0 | Recording of one hologram recorded in 0 sector |





## Bibliography

- [1] Shuhei Yoshida, Yosuke Takahata, Shuma Horiuchi, Manabu Yamamoto, "Diffraction model of peristrophic multiplexing with spherical reference wave," J. Opt. Soc. Am. A 32 (2), pp. 224-227, doi:10.1364/JOSAA.32.000224 (2015)
- [2] Zenta Ushiyama, Hiroyuki Kurata, Yu Tsukamoto, Shuhei Yoshida, Manabu Yamamoto, "Shift-Peristrophic Multiplexing for High Density Holographic Data Storage," Appl. Sci. 4 (2), pp. 148-157, doi:10.3390/app4020148 (2014)
- [3] Yosuke Takahata, Yo Kondo, Shuhei Yoshida, Manabu Yamamoto, "Signal quality improvement of holographic data storage using adaptive two-dimensional filter," Opt. Rev. 17 (3), pp. 204-209, doi:10.1007/s10043-010-0036-1 (2010)
- [4] Lin, Shu, and Daniel J. Costello, Jr., Error Control Coding: Fundamentals and Applications, Englewood Cliffs, NJ, Prentice-Hall, (1983)
- [5] Wicker, Stephen B., Error Control Systems for Digital Communication and Storage, Upper Saddle River, NJ, Prentice Hall, (1995)
- [6] M. Matsumoto and T. Nishimura, "Mersenne Twister: A 623-dimensionally equidistributed uniform pseudorandom number generator", ACM Trans. on Modeling and Computer Simulation Vol. 8, No. 1, January pp.3-30 (1998)
- [7] ECMA-377 (2007) Information Interchange on Holographic Versatile Disk (HVD) recordable cartridges – Capacity: 200 Gbytes per cartridge, 1<sup>st</sup> edition
- [8] ECMA-375 (2006) Case for 120 mm HVD-ROM disk
- [9] ETSI (EN 302307) (2005 March) Digital Video Broadcasting - Satellite - Second Generation (DVB-S2)

