

# ECMA

EUROPEAN COMPUTER MANUFACTURERS ASSOCIATION

---

## STANDARD ECMA-78

DATA INTERCHANGE ON 130 mm  
FLEXIBLE DISK CARTRIDGES  
USING MFM RECORDING AT 7958 ftprad  
ON 80 TRACKS ON EACH SIDE

2nd Edition – June 1986

Free copies of this document are available from ECMA,  
European Computer Manufacturers Association  
114 Rue du Rhône – 1204 Geneva (Switzerland)

# ECMA

EUROPEAN COMPUTER MANUFACTURERS ASSOCIATION

---

## STANDARD ECMA-78

DATA INTERCHANGE ON 130 mm  
FLEXIBLE DISK CARTRIDGES  
USING MFM RECORDING AT 7958 ftprad  
ON 80 TRACKS ON EACH SIDE

2nd Edition – June 1986

## BRIEF HISTORY

Technical Committee TC19 of ECMA began work on the standardization of flexible disk cartridges in 1974. Several drafts were developed and submitted to ISO/TC97/SC11 as proposals for international standards. As a result ECMA has produced a set of eight standards for different types of flexible disk cartridges :

- ECMA-54 : Data Interchange on 200 mm Flexible Disk Cartridges Using Double Frequency Recording at 13262 ftprad on one Side
- ECMA-59 : Data Interchange on 200 mm Flexible Disk Cartridges Using Two-Frequency Recording at 13262 ftprad on Both Sides
- ECMA-66 : Data Interchange on 130 mm Flexible Disk Cartridges Using Two-Frequency Recording at 7958 ftprad on One Side
- ECMA-69 : Data Interchange on 200 mm Flexible Disk Cartridges Using MFM Recording at 13262 ftprad on Both Sides
- ECMA-70 : Data Interchange on 130 mm Flexible Disk Cartridges Using MFM Recording at 7958 ftprad on Both Sides
- ECMA-78 : Data Interchange on 130 mm Flexible Disk Cartridges Using MFM Recording at 7958 ftprad on 80 Tracks on Each Side
- ECMA-99 : Data Interchange on 130 mm Flexible Disk Cartridges Using MFM Recording at 13262 ftprad on 80 Tracks on Each Side
- ECMA-100 : Data Interchange on 90 mm Flexible Disk Cartridges Using MFM Recording at 7958 ftprad on 80 Tracks on Each Side

Together with two standards specifying labelling and file structure:

- ECMA-91 : Flexible Disk Cartridges - File Structure and Labelling for Information Interchange
- ECMA-107 : Volume and File Structure of Flexible Disk Cartridge for Information Interchange

these standards provide for full data interchange on the specified types of flexible disk cartridges.

This 2nd Edition of Standard ECMA-78 was adopted by the General Assembly of ECMA of June 26, 1986.

## TABLE OF CONTENTS

	<u>Page</u>
SECTION I - GENERAL DESCRIPTION AND DEFINITIONS	
SCOPE AND CONFORMANCE	1
1. GENERAL DESCRIPTION	1
1.1 General Figures	1
1.2 Main Elements	1
1.3 Description	1
1.4 Optional Features	2
1.5 Definitions	2
1.5.1 Flexible Disk	2
1.5.2 Reference Flexible Disk Cartridge	2
1.5.3 Secondary Reference Flexible Disk Cartridge	2
1.5.4 Master Standard Reference Flexible Disk Cartridge	2
1.5.5 Secondary Standard Reference Flexible Disk Cartridge	2
1.5.6 Typical Field (for each side)	2
1.5.7 Reference Field	3
1.5.8 Test Recording Current (for each side)	3
1.5.9 Standard Reference Amplitudes (for each side)	3
1.5.10 Average Signal Amplitude	3
1.5.11 In-Contact	3
1.5.12 Direction of Rotation	3
1.5.13 Formatting	3
1.5.14 Initialization	3
1.5.15 Recording Area	3
SECTION II - MECHANICAL AND PHYSICAL CHARACTERISTICS	
2. GENERAL REQUIREMENTS	4
2.1 Environment and Transportation	4
2.1.1 Testing environment	4
2.1.2 Operating environment	4
2.1.3 Storage environment	4
2.1.4 Transportation	5
2.1.5 Handling	5
2.2 Materials	5
2.2.1 Jacket	5
2.2.2 Liner	5
2.2.3 Disk	5
2.2.4 Envelope	5
3. DIMENSIONAL CHARACTERISTICS	6
3.1 Jacket	6
3.1.1 Form	6
3.1.2 Thickness	6
3.1.3 Central Windows	6

TABLE OF CONTENTS (cont'd)

	<u>Page</u>
3.1.4 Index windows	7
3.1.5 Head windows	7
3.1.6 Reference Edge profile	7
3.1.7 Construction of the jacket	7
3.1.8 Notches	7
3.1.9 Write-enable notch	8
3.2 Liner	8
3.3 Disk	8
3.3.1 Diameter	8
3.3.2 Thickness	8
3.3.3 Index hole	8
3.3.4 Recording area	8
3.3.5 Sides	8
4. PHYSICAL CHARACTERISTICS	9
4.1 Flammability	
4.2 Coefficient of Linear Thermal Expansion of the Disk	9
4.3 Coefficient of Linear Hygroscopic Expansion of the Disk	9
4.4 Opacity	9
4.4.1 Opacity of the Jacket	9
4.4.2 Opacity of the disk	9
4.5 Torque	9
4.5.1 Starting torque	9
4.5.2 Running torque	9
SECTION III - MAGNETIC CHARACTERISTICS OF THE UNRECORDED FLEXIBLE DISK CARTRIDGE	
5. MAGNETIC CHARACTERISTICS	10
5.1 Track Geometry	10
5.1.1 Number of tracks	10
5.1.2 Width of tracks	10
5.1.3 Track location	10
5.1.4 Track number	10
5.1.5 Index	10
5.2 Functional Testing	11
5.2.1 Surface tests	11
5.2.2 Track quality tests	12
5.2.3 Rejection criteria	13
SECTION IV - TRACK FORMAT No 1	
TRACK FORMAT No 1	14
6. GENERAL REQUIREMENTS	14
6.1 Mode of recording	14

TABLE OF CONTENTS (cont'd)

	<u>Page</u>
6.2 Track location tolerance of the recorded flexible disk cartridge	14
6.3 Recording offset angle	14
6.4 Density of recording	14
6.5 Flux Transition Spacing	15
6.5.1 Flux transition spacing for track 00, Side 0	15
6.5.2 Flux transition spacing for all tracks other than track 00, Side 0	15
6.6 Average Signal Amplitude	16
6.7 Byte	16
6.8 Sector	16
6.9 Cylinder	16
6.10 Cylinder number	16
6.11 Data capacity of a track	16
6.12 Hexadecimal notation	16
6.13 Error Detection Characters (EDC)	17
7. TRACK LAYOUT AFTER FIRST FORMATTING FOR TRACK 00, SIDE 0	17
7.1 Index Gap	17
7.2 Sector Identifier	17
7.2.1 Identifier Mark	18
7.2.2 Address Identifier	18
7.3 Identifier Gap	18
7.4 Data Block	18
7.4.1 Data Mark	19
7.4.2 Data Field	19
7.4.3 EDC	19
7.5 Data Block Gap	19
7.6 Track Gap	19
8. TRACK LAYOUT AFTER THE FIRST FORMATTING FOR ALL TRACKS OTHER THAN TRACK 00, SIDE 0	19
8.1 Index Gap	20
8.2 Sector Identifier	20
8.2.1 Identifier Mark	20
8.2.2 Address Identifier	20
8.3 Identifier Gap	21
8.4 Data Block	21
8.4.1 Data Mark	21
8.4.2 Data Field	21
8.4.3 EDC	21
8.5 Data Block Gap	21
8.6 Track Gap	21

TABLE OF CONTENTS (cont'd)

	<u>Page</u>
9. TRACK LAYOUT OF A RECORDED FLEXIBLE DISK FOR DATA INTERCHANGE	22
9.1 Representation of Characters	22
9.2 Good and Bad Cylinder	22
9.3 Requirements for Cylinders	22
9.4 Layout of the Tracks of a Good Cylinder	22
9.4.1 Index Gap	22
9.4.2 Sector Identifier	22
9.5 Layout of the Tracks of a Bad Cylinder	24
9.5.1 Contents of the fields	24
9.5.2 Requirements for tracks	25
 SECTION V - TRACK FORMAT No 2	
TRACK FORMAT No 2	26
10. GENERAL REQUIREMENTS	26
10.1 Mode of Recording	26
10.2 Track Location Tolerance of the Recorded Flexible Disk Cartridge	26
10.3 Recording Offset Angle	26
10.4 Density of Recording	26
10.5 Flux Transition Spacing	26
10.6 Average Signal Amplitude	27
10.7 Byte	27
10.8 Sector	27
10.9 Cylinder	27
10.10 Cylinder Number	27
10.11 Data Capacity of a Track	27
10.12 Hexadecimal Notation	27
10.13 Error Detection Characters (EDC)	28
11. TRACK LAYOUT	28
11.1 Index Gap	28
11.2 Sector Identifier	28
11.2.1 Identifier Mark	28
11.2.2 Address Identifier	29
11.3 Identifier Gap	29
11.4 Data Block	29
11.4.1 Data Mark	30
11.4.2 Data Field	30
11.4.3 EDC	30
11.5 Data Block Gap	30
11.6 Track Gap	30
12. CODED REPRESENTATION OF DATA	30
12.1 Standards	30
12.2 Coding Methods	30



TABLE OF CONTENTS (cont'd)

	<u>Page</u>
APPENDIX A - MEASUREMENT OF THE CARTRIDGE THICKNESS	35
APPENDIX B - MEASUREMENT OF LIGHT TRANSMITTANCE	37
APPENDIX C - METHOD FOR MEASURING THE EFFECTIVE TRACK WIDTH	41
APPENDIX D - PROCEDURE AND EQUIPMENT FOR MEASURING FLUX TRANSITION SPACING	42
APPENDIX E - DATA SEPARATORS FOR DECODING MFM RECORDING	45
APPENDIX F - EDC IMPLEMENTATION	46
APPENDIX G - USE FOR HUB SUPPORT RINGS	47

SECTION I

GENERAL DESCRIPTION AND DEFINITIONS

## SCOPE AND CONFORMANCE

### SCOPE

This Standard ECMA-78 specifies the mechanical, physical and magnetic characteristics of a 130 mm magnetic flexible disk cartridge recorded at 7958 ftprad on 80 tracks on each side to provide physical interchangeability between data processing systems. It also specifies the quality of the recorded signals, the track layout and two track formats. Full data interchange between data processing systems is provided by either :

- Track Format No 1 together with the labelling system specified in Standard ECMA-91, or
- Track Format No 2 together with the volume and file structure specified in Standard ECMA-107.

### CONFORMANCE

A 130 mm flexible disk cartridge recorded on both sides is in conformance with this Standard if it meets all mandatory requirements of Section II, Section III and either Section IV or Section V of this Standard.

## 1. GENERAL DESCRIPTION

### 1.1 General Figures

A typical flexible disk cartridge is represented in Figs. 1 to 3.

Fig. 1, Flexible Disk Cartridge, shows the cartridge seen from above, Side 0 up.

Fig. 2, Section II-II, is a cross-section along line II-II in Fig. 1.

Fig. 3, Protective Envelope with Cartridge, shows a protective envelope with cartridge, Side 1 up.

### 1.2 Main Elements

The main elements of this flexible disk cartridge are :

- the recording disk
- the liner
- the jacket

The cartridge is stored in an envelope.

### 1.3 Description

The jacket shall have a square form. It includes a central window, an index window and a head window in both sides.

The liner is fixed to the inside of the jacket. It comprises two layers of material between which the disk is held. The liner has the same openings as the jacket.

The disk has only a central hole and an index hole.

#### 1.4 Optional Features

The interchange characteristics of the jacket allow for variations in its construction as follows.

- i) The jacket may include flaps (e.g. three flaps as shown in the diagram, or none).
- ii) The jacket may include notches along the Reference Edge.
- iii) The centre of the disk may be reinforced by hub support rings (see Appendix G).

#### 1.5 Definitions

For the purpose of this Standard the following definitions apply :

##### 1.5.1 Flexible Disk

A flexible disk which accepts and retains on the specified side or sides magnetic signals intended for input/output and storage purposes of information data processing and associated systems.

##### 1.5.2 Reference Flexible Disk Cartridge

A flexible disk cartridge arbitrarily selected for a given property for calibrating purposes.

##### 1.5.3 Secondary Reference Flexible Disk Cartridge

A flexible disk cartridge intended for routine calibrating purposes, the performance of which is known and stated in relation to that of the Reference Flexible Disk Cartridge.

##### 1.5.4 Master Standard Reference Flexible Disk Cartridge

A reference flexible disk cartridge selected as the standard for reference fields, signal amplitudes, resolution, peak shift and overwrite. Track 00 and Track 79 on both sides are declared as reference tracks.

###### Note 1:

A Master Standard has been established by the Physikalisch-Technische Bundesanstalt (PTB), Bundesallee 100, D-3300 Braunschweig, Germany.

##### 1.5.5 Secondary Standard Reference Flexible Disk Cartridge

A flexible disk cartridge the performance of which is known and stated in relation to that of the Master Standard Reference Flexible Disk Cartridge.

###### Note 2:

Secondary Standard Reference Flexible Disk Cartridges can be ordered from PTB Lab. 1.41 under Part Number RM 7487 as long as available.

It is intended that these be used for calibrating further cartridges for use in routine calibration.

##### 1.5.6 Typical Field (for each side)

The minimum recording field which, when applied to a flexible disk cartridge, causes a signal output equal to 95 % of the maximum Average Signal Amplitude when taken as a function of the recording field at the specified track and flux transition density of that flexible disk cartridge.

1.5.7 Reference Field

The Reference Field is the typical field of the Master Standard Reference Flexible Disk Cartridge.

1.5.8 Test Recording Current (for each side)

The test Recording Current is the current between 145% and 155% of the current which produces the Reference Field at 125 000 ftps on track 00 on both sides.

1.5.9 Standard Reference Amplitudes (for each side)

The Standard Reference Amplitudes (SRA) are the Average Signal Amplitudes derived from the reference tracks of the Master Standard Reference Flexible Disk Cartridge using the appropriate Test Recording Current.

SRA<sub>1f</sub> is the Average Signal Amplitude from a recording written using 125 000 ftps on track 00.

SRA<sub>2f</sub> is the Average Signal Amplitude from a recording written using 250 000 ftps on track 78.

1.5.10 Average Signal Amplitude

The Average Signal Amplitude for a track is the arithmetically averaged value of the output voltages measured peak-to-peak over the whole track.

1.5.11 In-Contact

An operating condition in which the magnetic surface of the disk intended for data storage is in physical contact with the magnetic heads.

1.5.12 Direction of Rotation

The direction of rotation shall be counterclockwise when looking at Side 0.

1.5.13 Formatting

Writing the proper control information establishing the physical cylinders and designating addresses of physical records on the surfaces of the flexible disk.

1.5.14 Initialization

Writing any information initially required to be on the flexible disk cartridge, e.g. the Volume Label, prior to the commencement of general processing or use.

1.5.15 Recording Area

That area of each disk surface with which the head may come in contact.

SECTION II

MECHANICAL AND PHYSICAL CHARACTERISTICS

## 2. GENERAL REQUIREMENTS

### 2.1 Environment and Transportation

#### 2.1.1 Testing environment

Tests and measurements made on the cartridge to check the requirements of this Standard shall be carried out under following conditions :

Temperature : 23 °C ± 2 °C

RH : 40% to 60%

Conditioning before testing : 24 hours minimum

The temperature and the RH shall be measured in the air immediately surrounding the cartridge.

The stray magnetic field at any point on the disk surface, including that resulting from the concentrating effect of the recording head, shall not exceed 4000 A/m.

#### 2.1.2 Operating environment

Cartridges used for data interchange shall be operated under the following conditions :

Temperature : 10 °C to 51,5 °C

RH : 20% to 80%

Wet bulb temperature : less than 29 °C

The temperature and the RH shall be measured in the air immediately surrounding the cartridge. It is recommended that the rate of change of the temperature should not exceed 20 °C per hour.

##### Note 3:

For reliable interchange it is recommended that the temperature and humidity conditions when reading are not at the opposite extremes to the conditions when writing.

There shall be no deposit of moisture on or in the cartridge.

The stray magnetic field at any point on the disk surface, including that resulting from the concentrating effect of the recording head, shall not exceed 4000 A/m.

#### 2.1.3 Storage environment

During storage the cartridges shall be kept within the following conditions :

Temperature : 4 °C to 51,5 °C

RH : 8% to 80%

Each cartridge shall be in an envelope and in an upright position. There shall be no deposit of moisture on or in the cartridge.

The ambient stray magnetic field at any point on the disk surface shall not exceed 4000 A/m.

Note 4:

Cartridges which have been stored at temperatures and humidities outside the operating conditions may exhibit degraded performance characteristics. Such cartridges should be subject to a conditioning period of not less than 24 hours within the operating environment prior to use.

2.1.4 Transportation

Responsibility for ensuring that adequate precautions are taken during transportation shall be with the sender. During transportation the cartridge shall be in its envelope and in a protective package. The latter shall be free from dust or extraneous matter. It shall have a clean interior and construction minimizing the ingress of dust and moisture. It is recommended that a sufficient space exists between cartridge and outer surface of the final container, so that risk of damage due to stray magnetic fields will be negligible.

It is recommended that the following conditions be not exceeded :

Temperature : -40 °C to 51,5 °C

Maximum rate of temperature change : 20 °C per hour

RH : 8% to 90%

There should be no deposit of moisture on or in the cartridge.

2.1.5 Handling

The cartridge shall stay out of its envelope for the shortest time possible. When handling the cartridge the operator shall not touch the exposed magnetic surfaces of the disk and shall avoid exposing the cartridge to direct sunlight, moisture and dust.

2.2 Materials

2.2.1 Jacket

The jacket may be constructed from any suitable material.

2.2.2 Liner

The material of the liner shall be able to retain dust without damage to the disk.

2.2.3 Disk

The disk may be constructed from any suitable material (e.g. bi-axially oriented polyethylene terephthalate) coated on both sides with a strong and flexible layer of magnetic material (e.g.  $\gamma$ -Fe<sub>2</sub>O<sub>3</sub>).

2.2.4 Envelope

The envelope may be manufactured from any suitable material (e.g. paper).



### 3. DIMENSIONAL CHARACTERISTICS

The dimensional characteristics listed in the following clauses are indicated in Figs. 4 to 8.

- Fig. 4 Jacket Dimensions, shows the jacket.
- Fig. 5 Cartridge Thickness, shows a partial cross-section of the jacket.
- Fig. 6 Disk Dimensions, shows the disk.
- Fig. 7 Disk Thickness, shows a cross-section of the disk.
- Fig. 8 Pressure Pad, shows the dimensions.

All dimensions are referred to the Reference Edge of the cartridge (see Fig. 4).

#### 3.1 Jacket

##### 3.1.1 Form

The jacket shall have a square form with angles of  $90^\circ \pm 30'$  and a side length

$$l_1 = 133,3 \text{ mm} \pm 0,4 \text{ mm}$$

##### 3.1.2 Thickness

###### 3.1.2.1 Jacket Wall and Liner

In an area defined by

$$r_1 = 35 \text{ mm}$$

$$r_2 = 50 \text{ mm}$$

and with a probe having a diameter of 15 mm applied against the cartridge with a force of 1 N, the thickness of the jacket wall and liner shall be

$$e_1 = 0,45 \text{ mm} \pm 0,15 \text{ mm}$$

###### 3.1.2.2 Cartridge

The overall thickness of the cartridge shall be (see also 3.1.7) :  $1,2 \text{ mm} < e_2 < 2,1 \text{ mm}$ , when measured according to A.1 and A.2 of Appendix A.

The cartridge shall fall freely through a gauge with a 2,6 mm wide opening having flat, vertical walls and a depth of 150 mm.

##### 3.1.3 Central windows

The central windows shall have a diameter

$$d_1 = 39,7 \text{ mm} \pm 0,2 \text{ mm}$$

The position of their centre is defined by

$$l_2 = 66,65 \text{ mm} \pm 0,30 \text{ mm}$$

3.1.4 Index windows

Location

The centre of the index windows shall be defined by

$$l_3 = 42,10 \text{ mm} \pm 0,25 \text{ mm}$$

$$l_4 = 60,00 \text{ mm} \pm 0,25 \text{ mm}$$

Diameter

The diameter of the index windows shall be defined by

$$d_2 = 6,35 \text{ mm} \pm 0,20 \text{ mm}$$

3.1.5 Head windows

Location

The location of the lowest point of the head windows shall be defined by

$$l_5 = 3,30 \text{ mm} \pm 0,25 \text{ mm}$$

Dimensions

The width of the head windows shall be

$$l_6 = 12,7 \text{ mm} \pm 0,2 \text{ mm}$$

The nominal radius of their ends shall be

$$r_3 = 6,35 \text{ mm}$$

Their length shall be

$$l_7 = 35,00 \text{ mm} \pm 0,25 \text{ mm}$$

3.1.6 Reference Edge profile

Within an area defined by

$$l_8 = 25 \text{ mm}$$

the Reference Edge shall have a convex profile, e.g. be rounded off with one or more radii of 0,3 mm minimum.

3.1.7 Construction of the jacket

If the jacket utilizes flaps, their width shall not exceed

$$l_9 = 12 \text{ mm}$$

The total thickness  $e_2$  of the cartridge with flaps shall satisfy the conditions of 3.1.2.

3.1.8 Notches

Two notches may be provided along the Reference Edge. If provided, they have to be entirely contained within areas defined by :

$$l_{10} = 48 \text{ mm min.}$$

$$l_{11} = 58 \text{ mm max.}$$

$$l_{12} = 75 \text{ mm min.}$$

$$l_{13} = 85,5 \text{ mm max.}$$

$$l_{14} = 2,0 \text{ mm max.}$$

### 3.1.9 Write-enable notch

The position and size of the write-enable notch shall be defined by :

$$l_{19} = 96,7 \text{ mm} \pm 0,2 \text{ mm}$$

$$l_{20} = 6,35 \text{ mm} \pm 0,13 \text{ mm}$$

$$l_{21} = 3,8 \text{ mm} \pm 0,2 \text{ mm}$$

Writing is inhibited by covering the notch with a material of sufficient stiffness and/or opacity.

### 3.2 Liner

The liner shall always cover the recording area (3.3.4). However, no part of the liner shall protrude by more than 0,5 mm into the openings of the jacket.

### 3.3 Disk

#### 3.3.1 Diameter

The external diameter of the disk shall be :

$$d_3 = 130,2 \text{ mm} \pm 0,2 \text{ mm}$$

The inner diameter of the disk shall be :

$$d_4 = 28,57 \text{ mm} \pm 0,025 \text{ mm}$$

#### 3.3.2 Thickness

The thickness of the disk shall be :

$$e_3 = 0,080 \text{ mm} \pm 0,010 \text{ mm}$$

not including hub support rings, if fitted.

#### 3.3.3 Index hole

##### Location

The location of the index hole shall be defined by :

$$r_4 = 25,4 \text{ mm} \pm 0,1 \text{ mm}$$

##### Diameter

The diameter of the index hole shall be :

$$d_5 = 2,54 \text{ mm} \pm 0,10 \text{ mm}$$

#### 3.3.4 Recording area

The recording area shall be defined on both sides by :

$$r_5 = 31,3 \text{ mm max.}$$

$$r_6 = 62,5 \text{ mm min.}$$

#### 3.3.5 Sides

For convenience of description the two sides are defined as Side 0 and Side 1; they are shown in Figs. 1-4 and Fig. 8.

#### 4. PHYSICAL CHARACTERISTICS

##### 4.1 Flammability

Disk, jacket and/or liner components which ignite from a match flame and when so ignited continue to burn in a still carbon dioxide atmosphere shall not be used.

##### 4.2 Coefficient of Linear Thermal Expansion of the Disk

The coefficient of thermal expansion of the disk shall be :

$$(17 \pm 8) \cdot 10^{-6} \text{ per } ^\circ\text{C}$$

##### 4.3 Coefficient of Linear Hygroscopic Expansion of the Disk

The coefficient of hygroscopic expansion of the disk shall be:

$$(0 \text{ to } 15) \cdot 10^{-6} \text{ per } \% \text{ RH}$$

##### 4.4 Opacity

###### 4.4.1 Opacity of the jacket

The jacket shall have a light transmittance of less than 1% when measured according to Appendix B.

###### 4.4.2 Opacity of the disk

The disk shall have a light transmittance of less than 1% when measured according to Appendix B.

##### 4.5 Torque

###### 4.5.1 Starting torque

The starting torque, without heads and pads loaded to the cartridge, shall not exceed 0,01 N.m.

###### 4.5.2 Running torque

When the disk cartridge is tested at a rotational speed of 300 rpm  $\pm$  6 rpm, with a pressure pad of 280 mm<sup>2</sup>  $\pm$  10 mm<sup>2</sup> surface applied with a force of 0,70 N  $\pm$  0,05 N and located parallel to the head windows as defined in Fig. 8 by :

$$l_{15} = 45 \text{ mm}$$

$$l_{16} = 55 \text{ mm}$$

$$l_{17} = 7 \text{ mm}$$

$$l_{18} = 35 \text{ mm}$$

the torque necessary to rotate the disk shall be between 0,01 N.m and 0,03 N.m.

ch

e:

1%

SECTION III

f

ed

MAGNETIC CHARACTERISTICS  
OF THE UNRECORDED FLEXIBLE DISK CARTRIDGE

## 5. MAGNETIC CHARACTERISTICS

### 5.1 Track Geometry

#### 5.1.1 Number of tracks

There shall be 80 discrete concentric tracks on each side of the disk in the recording area (3.3.4) for data interchange.

#### 5.1.2 Width of tracks

The recorded track width on the disk surface shall be :

$$0,155 \text{ mm} \pm 0,015 \text{ mm}$$

The area between the tracks shall be erased. The method of measuring effective track width is given in Appendix C.

#### 5.1.3 Track location

##### 5.1.3.1 Nominal locations

The nominal radius of the centrelines of all tracks shall be calculated by using the formula :

$$R_n = x - \frac{n}{96} \cdot 25,4 \text{ mm}$$

where : n is the track number : n = 00 to 79

x = 57,150 mm for Side 0

x = 55,033 mm for Side 1.

Therefore, each track on Side 1 is offset inwards by eight track positions from the track on Side 0 having the same track number.

##### 5.1.3.2 Track location tolerance

The centrelines of the recorded tracks shall be within  $\pm 0,025$  mm of the nominal positions, when measured in the testing environment (2.1.1).

#### 5.1.4 Track number

The track number shall be a two-digit decimal number (00 to 79) for each side which identifies the tracks consecutively, starting at the outermost track (00).

#### 5.1.5 Index

The index signal is used only for timing purposes during formatting. The index is the point which determines the beginning and the end of the track. At the instant of having detected the leading edge of the index hole, the index is under the write/read gap.

## 5.2 Functional Testing

For the purpose of the following tests the same drive unit shall be used for writing and reading operations both for the disk under test and for the Secondary Standard Reference Flexible Disk Cartridge.

The in-contact operating condition shall be used.

### 5.2.1 Surface tests

The magnetic properties of both data surfaces are defined by the testing requirements given below.

#### 5.2.1.1 Test conditions

The disk shall be tested at 300 rpm  $\pm$  6 rpm. The test frequencies used shall be :

1f = 125 000 ftps  $\pm$  125 ftps

2f = 250 000 ftps  $\pm$  250 ftps

The frequency(ies) to be used is specified for each test.

#### 5.2.1.2 Typical Field

The Typical Field of the disk under test shall be within  $\pm$  20% of the Reference Field. It shall be measured using 1f on track 00 on each side.

#### 5.2.1.3 Average Signal Amplitude

When the disk under test has been recorded with the Test Recording Current, then read back and compared with the Secondary Standard Reference Flexible Disk Cartridge recorded under the same conditions, and on the same system, the Average Signal Amplitude shall be :

Side 0, track 00, using 1f : less than 130% of  $SRA_{1f}$   
for Side 0

Side 0, track 78, using 2f : more than 80% of  $SRA_{2f}$   
for Side 0

Side 1, track 00, using 1f : less than 130% of  $SRA_{1f}$   
for Side 1

Side 1, track 78, using 2f : more than 80% of  $SRA_{2f}$   
for Side 1

These measurements are performed on tracks 78 because their positions correspond to the certified areas of RM 7487.

#### 5.2.1.4 Resolution

For each side record on track 78, using the test recording current for that Side, the ratio

$$\frac{\text{Average Signal Amplitude Using } 2f}{\text{Average Signal Amplitude Using } 1f}$$

shall be greater than 90% of the same ratios for the corresponding sides of the Master Standard Reference Flexible Disk Cartridge.

5.2.1.5 Overwrite

On track 00 of each side, after recording with the Test Recording Current, first using 1f and then overwriting with 2f for one revolution, the ratio :

Residual Average Signal Amplitude at 1f after overwrite using 2f  
Average Signal Amplitude after first recording using 1f

shall be less than 100% of the value of the same ratio for the Master Standard Reference Flexible Disk Cartridge. This test shall be performed on both sides, and a frequency-selective voltmeter shall be used.

5.2.1.6 Modulation

The modulation shall be :

$$\frac{\text{Maximum mean} - \text{Minimum mean}}{\text{Maximum mean} + \text{Minimum mean}} \cdot 100\%$$

The maximum mean shall be the average value of the amplitude modulated output voltage in that part of the track with the maximum amplitudes, and the minimum mean shall be that in the respective part with the minimum amplitudes. Output voltage shall be measured peak-to-peak, averaging shall be done over about 2000 consecutive flux transitions.

On both sides, on track 00 using 1f and on track 79 using 2f, modulation shall be less than 10%.

5.2.2 Track quality tests

These tests shall apply to all usable tracks at the defined positions on each side. The Test Recording Current shall be used.

5.2.2.1 Missing pulse

Write a track at 2f with the appropriate Test Recording Current. Any playback signal, when measured base-to-peak, which is less than 40% of half the arithmetically averaged value of the output voltages measured peak-to-peak over the preceding 2000 consecutive flux transitions, shall be a missing pulse.

5.2.2.2 Extra pulse

Write a track at 2f with the appropriate Test Recording Current, erase for five revolutions with a constant direct current equivalent to the quiescent value of the Test Recording Current. Any playback signal which, when measured base-to-peak, including the statistical noise and the residual signal of the disk, exceeds 20% of half the Average Signal Amplitude at 2f of the track under test, shall be an extra pulse.



5.2.3 Rejection criteria

5.2.3.1 Defective track

A track on which one or more missing and/or extra pulses are detected in the same position(s) on consecutive passes shall be a defective track. The applicable number of consecutive passes shall be a matter for agreement between purchaser and supplier.

5.2.3.2 Requirements for tracks

As initially received from the medium supplier, the cartridge shall have no defective tracks.

5.2.3.3 Rejected cartridge

A cartridge which does not meet the requirements of 5.2.3.2 shall be rejected.

SECTION IV

TRACK FORMAT No 1

TRACK FORMAT NO.1

6. GENERAL REQUIREMENTS

6.1 Mode of recording

6.1.1 Track 00, Side 0

The mode of recording shall be Two-Frequency where the start of every bit cell is a clock flux transition. A ONE is represented by a data flux transition between two clock flux transitions.

Exceptions to this are defined in 6.12.

6.1.2 All tracks other than track 00, Side 0

The mode of recording shall be Modified Frequency Modulation (MFM) for which the conditions are :

- i) a flux transition shall be written at the centre of each bit cell containing a ONE.
- ii) a flux transition shall be written at each cell boundary between consecutive bit cells containing ZEROS.

Exceptions to this are defined in 6.12.

6.2 Track location tolerance of the recorded flexible disk cartridge

The centrelines of the recorded tracks shall be within  $\pm 0,0425$  mm of the nominal positions.

6.3 Recording offset angle

At the instant of writing or reading a magnetic transition, the transition shall have an angle  $\alpha = 0^0' \pm 18'$  with the radius.

Note 5 :

As tracks may be written and overwritten at extremes of the tolerances given in 6.2 and 6.3, a band of old information may be left at one edge of the newly written data and would constitute unwanted noise when reading. It is, therefore, necessary to trim the edges of the tracks by erasure after writing.

6.4 Density of recording

6.4.1 The nominal density of recording shall be 7958 flux transitions per radian. The nominal bit cell length for track 00, Side 0 is 251,3 microradians, and for all the other tracks it is 125,7 microradians.

6.4.2 The long-term average bit cell length shall be the average bit cell length measured over a sector. It shall be within  $\pm 3,5\%$  of the nominal bit cell length.

6.4.3 The short-term average bit cell length, referred to a particular bit cell, shall be the average of the lengths of the preceding eight bit cells. It shall be within  $\pm 8\%$  of the long-term average bit cell length.

## 6.5 Flux Transition Spacing

The instantaneous spacing between flux transitions may be influenced by the writing and reading processes, the bit sequence recorded (pulse crowding effects), and other factors. The locations of the transitions are defined as the locations of the peaks in the signal when reading. Tests should be carried out using a peak-sensing amplifier.

### 6.5.1 Flux transition spacing for track 00, Side 0

- 6.5.1.1 The spacing between two clock flux transitions surrounding a data flux transition or between two data flux transitions surrounding a clock flux transition shall be between 90% and 140% of the nominal bit cell length.
- 6.5.1.2 The spacing between two clock flux transitions not surrounding a data flux transition or between two data flux transitions surrounding a missing clock flux transition shall be between 60% and 110% of the nominal bit cell length.
- 6.5.1.3 The spacing between a data flux transition and the preceding clock flux transition (when not missing) or between a clock flux transition and the preceding data flux transition (when not missing) shall be between 45% and 70% of the nominal bit cell length.

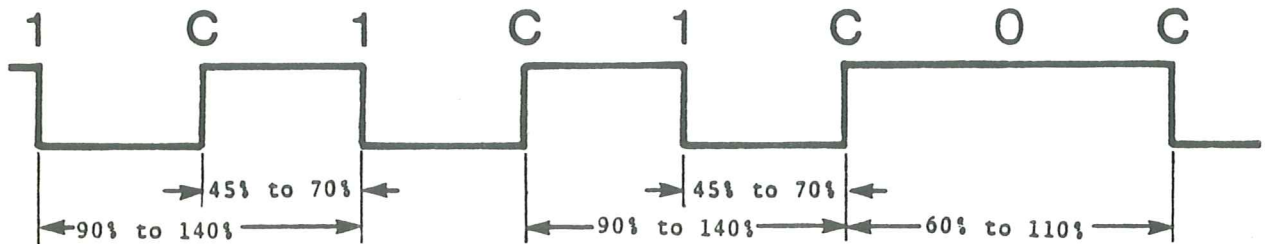

### 6.5.2 Flux transition spacing for all tracks other than track 00, Side 0

- 6.5.2.1 The spacing between the flux transitions in a sequence of ONES shall be between 80% and 120% of the short-term average bit cell length.
- 6.5.2.2 The spacing between the flux transition for a ONE and that between two ZEROS preceding or following it shall be between 130% and 165% of the short-term average bit cell length.
- 6.5.2.3 The spacing between the two ONE flux transitions surrounding a ZERO bit cell shall lie between 185% and 225% of the short-term average bit cell.

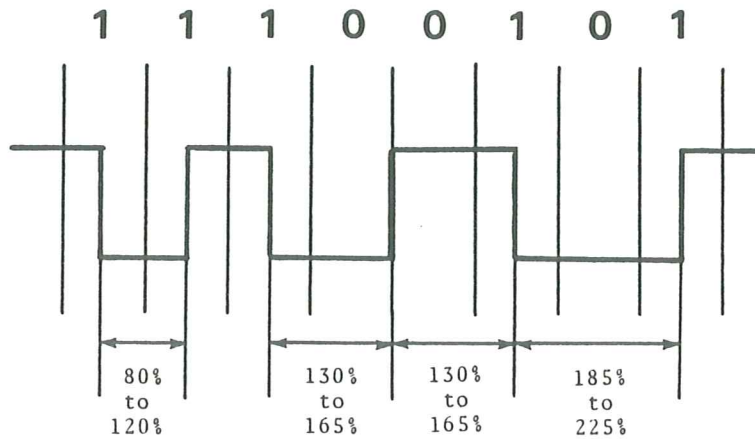

6.6 Average Signal Amplitude

For each side the Average Signal Amplitude on any non-defective track (5.2.3.1) of the interchanged flexible disk cartridge shall be less than 160% of  $SRA_{1f}$  and more than 40% of  $SRA_{2f}$ .

6.7 Byte

A byte is a group of eight bit-positions, identified  $B_1$  to  $B_8$ , with  $B_8$  most significant and recorded first.

The bit in each position is a ZERO or a ONE.

6.8 Sector

All tracks are divided into 16 sectors.

6.9 Cylinder

A pair of tracks, one on each side, having the same track number.

6.10 Cylinder number

The cylinder number shall be a two-digit number identical with the track number of the tracks of the cylinder.

6.11 Data capacity of a track

The data capacity of track 00, Side 0 shall be 2048 bytes. The data capacity of all tracks other than track 00, Side 0 shall be 4096 bytes.

6.12 Hexadecimal notation

Hexadecimal notation is used hereafter to denote a number of bytes :

(00) for ( $B_8$  to  $B_1$ ) = 00000000

(01) for ( $B_8$  to  $B_1$ ) = 00000001

(FF) for ( $B_8$  to  $B_1$ ) = 11111111

(FE)\* for ( $B_8$  to  $B_1$ ) = 11111110

where the clock transitions of  $B_6$ ,  $B_5$  and  $B_4$  are missing.

(FB)\* for (B<sub>8</sub> to B<sub>1</sub>) = 11111011

where the clock transitions of B<sub>6</sub>, B<sub>5</sub> and B<sub>4</sub> are missing.

(F8)\* for (B<sub>8</sub> to B<sub>1</sub>) = 11111000

where the clock transitions of B<sub>6</sub>, B<sub>5</sub> and B<sub>4</sub> are missing.

(4E) for (B<sub>8</sub> to B<sub>1</sub>) = 01001110

(FE) for (B<sub>8</sub> to B<sub>1</sub>) = 11111110

(FB) for (B<sub>8</sub> to B<sub>1</sub>) = 11111011

(F8) for (B<sub>8</sub> to B<sub>1</sub>) = 11111000

(A1)\* for (B<sub>8</sub> to B<sub>1</sub>) = 10100001

where the boundary transition between B<sub>3</sub> and B<sub>4</sub> is missing.

### 6.13 Error Detection Characters (EDC)

The two EDC-bytes are hardware generated by shifting serially the relevant bits, specified later for each part of the track through a 16-bit shift register described by :

$$X^{16} + X^{12} + X^5 + 1$$

(See also Appendix F).

## 7. TRACK LAYOUT AFTER FIRST FORMATTING FOR TRACK 00, SIDE 0

After first formatting there shall be 16 usable sectors on the track. The layout of the track shall be as shown below.

During formatting the rotational speed of the disk, averaged index to index, shall be 300 rpm ± 6 rpm.

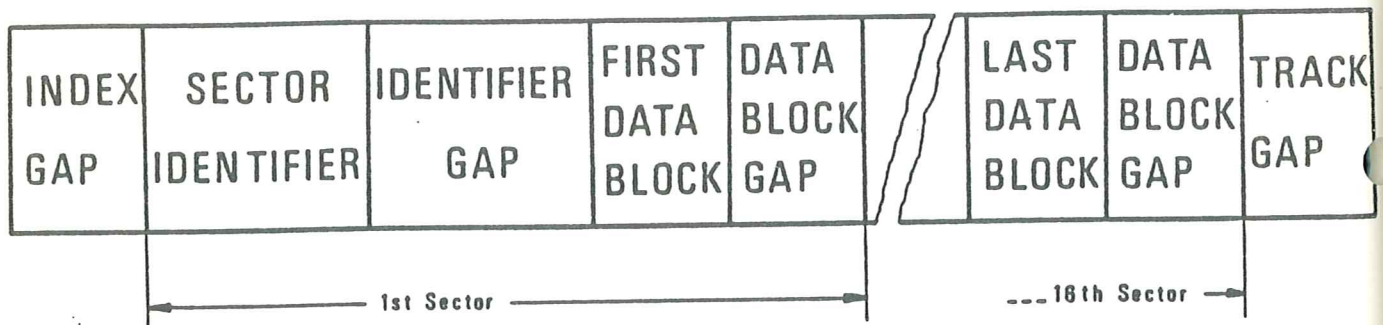

### 7.1 Index Gap

At nominal density this field shall comprise 16 (FF)-bytes. Writing the Index Gap is started when the Index hole is detected. Any of the first 8 bytes may be ill-defined due to subsequent overwriting.

### 7.2 Sector Identifier

This field shall be as follows :

SECTOR IDENTIFIER						
IDENTIFIER MARK		ADDRESS IDENTIFIER				
6 Bytes (00)	1 Byte (FE)*	TRACK ADDRESS		S	1 Byte (00)	EDC
		C 1 Byte (00)	Side 1 Byte (00)	1 Byte		1 Byte

7.2.1 Identifier Mark

This field shall comprise 7 bytes :

- 6 (00)-bytes
- 1 (FE)\*-byte

7.2.2 Address Identifier

This field shall comprise 6 bytes.

7.2.2.1 Track Address

This field shall comprise 2 bytes:

Cylinder Address (C)

This field shall specify in binary notation the cylinder address. It shall be (00) for all sectors.

Side Number (Side)

This field shall specify the side of the disk.

It shall be (00) for all sectors.

7.2.2.2 Sector Number (S)

The 3rd byte shall specify in binary notation the sector number from 01 for the 1st sector to 16 for the last sector. The 16 sectors shall be numbered in the natural order: 1, 2, 3, ..., 15, 16.

7.2.2.3 4th Byte

The 4th byte shall always be a (00)-byte.

7.2.2.4 EDC

These two bytes shall be generated as defined in 6.1.13 using the bytes of the Sector Identifier starting with the (FE)\*-byte (7.2.1) of the Identifier Mark and ending with the 4th byte (7.2.2.3) of the Address Identifier.

7.3 Identifier Gap

This field shall comprise 11 initially recorded (FF)-bytes.

7.4 Data Block

This field shall be as follows:

DATA BLOCK			
DATA MARK		DATA FIELD	EDC
6 Bytes (00)	1 Byte (FB)*	128 Bytes	2 Bytes

7.4.1 Data Mark

This field shall comprise:

- 6 (00)-bytes
- 1 (FB)\*-byte.

7.4.2 Data Field

This field shall comprise 128 bytes. No requirements are implied beyond the correct EDC for the content of this field (see also 9.4.2.4.2).

7.4.3 EDC

These two bytes shall be generated as defined in 6.1.13 using the bytes of the Data Block starting with the 7th byte of the Data Mark (7.4.1) and ending with the last byte of the Data Field (7.4.2).

7.5 Data Block Gap

This field shall comprise 27 initially recorded (FF)-bytes. It is recorded after each Data Block and it precedes the following Sector Identifier. After the last Data Block it precedes the Track Gap.

7.6 Track Gap

This field shall follow the Data Block Gap of the 16th sector. (FF)-bytes are written until the Index hole is detected, unless it has been detected during writing of the last Data Block Gap, in which case there shall be no Track Gap.

8. TRACK LAYOUT AFTER THE FIRST FORMATTING FOR ALL TRACKS OTHER THAN TRACK 00, SIDE 0

After the first formatting there shall be 16 usable sectors on each track. The layout of each track shall be as shown below.

During formatting the rotational speed of the disk, averaged index to index, shall be 300 rpm  $\pm$  6 rpm.

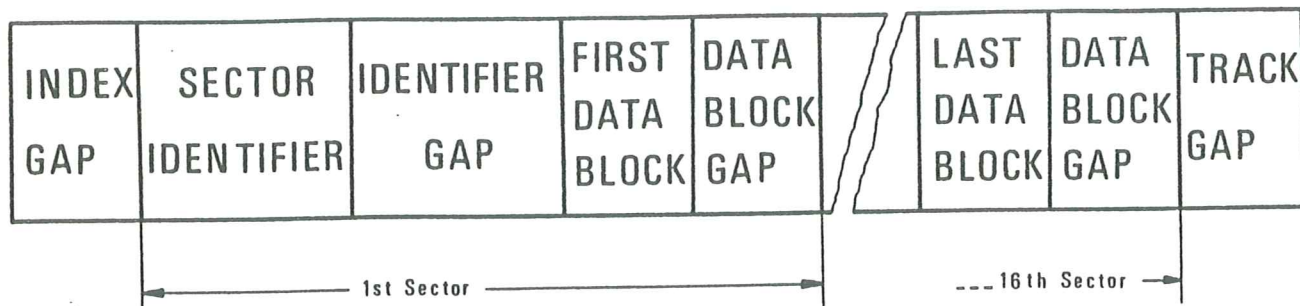



8.1 Index Gap

At nominal density this field shall comprise 32 (4E)-bytes. Writing the Index Gap is started when the Index hole is detected. Any of the first 16 bytes may be ill-defined due to subsequent overwriting.

8.2 Sector Identifier

This field shall be defined as follows:

SECTOR IDENTIFIER							
IDENTIFIER MARK			ADDRESS IDENTIFIER				
12 Bytes (00)	3 Bytes (A1)*	1 Byte (FE)	TRACK ADDRESS		S	1 Byte (01)	EDC
			C 1 Byte	Side 1 Byte (00) or (01)	1 Byte		2 Bytes

8.2.1 Identifier Mark

This field shall comprise 16 bytes:

- 12 (00)-bytes
- 3 (A1)\*-bytes
- 1 (FE)-byte

8.2.2 Address Identifier

This field shall comprise 6 bytes.

8.2.2.1 Track Address

This field shall comprise 2 bytes:

Cylinder Address (C)

This byte shall specify in binary notation the cylinder address from 00 for the outermost cylinder to 77 for the innermost cylinder.

Side Number (Side)

This byte shall specify the side of the disk. On Side 0 it shall be (00) on all tracks. On Side 1 it shall be (01) on all tracks.

8.2.2.2 Sector Number (S)

This byte shall specify in binary notation the sector number from 01 for the 1st sector to 16 for the last sector. The sectors shall be numbered in the natural order: 1, 2, 3, ..., 15, 16.

8.2.2.3 4th Byte

This byte shall always be a (01)-byte.

8.2.2.4 EDC

These two bytes shall be generated as defined in 6.1.13 using the bytes of the Sector Identifier starting with the first (A1)\*-byte (8.2.1) of the Identifier Mark and ending with the 4th byte (8.2.2.3) of the Address Identifier.

8.3 Identifier Gap

This field shall comprise 22 initially recorded (4E)-bytes.

8.4 Data Block

This field shall be as follows:

DATA BLOCK				
DATA MARK			DATA FIELD	EDC
12 Bytes (00)	3 Bytes (A1)*	1 Byte (FB)	256 Bytes	2 Bytes

8.4.1 Data Mark

This field shall comprise:

- 12 (00)-bytes
- 3 (A1)\*-bytes
- 1 (FB)-byte

8.4.2 Data Field

This field shall comprise 256 bytes.

No requirements are implied beyond the correct EDC for the content of this field (see also 9.4.2.4.2).

8.4.3 EDC

These two bytes shall be generated as defined in 6.1.13 using the bytes of the Data Block starting with the first (A1)\*-byte of the Data Mark (8.4.1) and ending with the last byte of the Data Field (8.4.2).

8.5 Data Block Gap

This field shall comprise 54 initially recorded (4E)-bytes. It is recorded after each Data Block and it precedes the following Sector Identifier. After the last Data Block it precedes the Track Gap.

8.6 Track Gap

This field shall follow the Data Block Gap of the last sector. (4E)-bytes are written until the Index hole is detected, unless it has been detected during writing of the last Data Block Gap, in which case there shall be no Track Gap.

## 9. TRACK LAYOUT OF A RECORDED FLEXIBLE DISK FOR DATA INTERCHANGE

### 9.1 Representation of Characters

Characters shall be represented by means of the 7-Bit Coded Character Set (Standard ECMA-6) and, were required, by its 7-bit or 8-bit extensions (Standard ECMA-35) or by means of the 8-bit Coded Character Set (Standard ECMA-43).

Each 7-bit coded character shall be recorded in bit-positions  $B_7$  to  $B_1$  of a byte; bit-position  $B_8$  shall be recorded with bit ZERO.

The relationship shall be as follows:

Bits of the 7-bit combination	0	$b_7$	$b_6$	$b_5$	$b_4$	$b_3$	$b_2$	$b_1$
Bit-positions in the byte	$B_8$	$B_7$	$B_6$	$B_5$	$B_4$	$B_3$	$B_2$	$B_1$

Each 8-bit coded character shall be recorded in bit-position  $B_8$  to  $B_1$  of a byte.

The relationship shall be as follows:

Bits of the 8-bit combination	$b_8$	$b_7$	$b_6$	$b_5$	$b_4$	$b_3$	$b_2$	$b_1$
Bit-positions in the byte	$B_8$	$B_7$	$B_6$	$B_5$	$B_4$	$B_3$	$B_2$	$B_1$

### 9.2 Good and Bad Cylinder

A good cylinder is a cylinder which has both tracks formatted according to 9.4.

A bad cylinder is a cylinder which has both tracks formatted according to 9.5.

### 9.3 Requirements for Cylinders

Cylinder 00 shall be a good cylinder and shall have no defective sectors on Side 0. There shall be at least 77 good cylinders between cylinder 01 and cylinder 79.

### 9.4 Layout of the Tracks of a Good Cylinder

References to sub-clauses of 6.2 are for track 00, Side 0. References to sub-clauses of 6.3 are for all other tracks.

#### 9.4.1 Index Gap

Description: see 7.1 and 8.1.

#### 9.4.2 Sector Identifier

##### 9.4.2.1 Identifier Mark

Description: see 7.2.1 and 8.2.1.

##### 9.4.2.2 Address Identifier

Description: see 7.2.2 and 8.2.2.

9.4.2.2.1 Track Address

This field shall comprise 2 bytes:

Cylinder Address (C)

This field shall specify in binary notation the cylinder address from 00 for the outermost cylinder to 77 for the innermost cylinder.

A unique cylinder number is associated with each cylinder (see 6.10). Two of these cylinders are intended for use only when there are one or two defective cylinders. Each good cylinder possesses a unique cylinder address; a defective cylinder does not possess a cylinder address. Cylinder addresses are assigned consecutively to the good cylinders in the ascending sequence of cylinder numbers.

Side Number (Side)

Description: see 7.2.2.1 and 8.2.2.1.

9.4.2.2.2 Sector Number (S)

Description: see 7.2.2.2 and 8.2.2.2.

9.4.2.2.3 4th Byte

Description: see 7.2.2.3 and 8.2.2.3.

9.4.2.2.4 EDC

Description: see 7.2.2.4 and 8.2.2.4.

9.4.2.3 Identifier Gap

Description: see 7.3 and 8.3. These bytes may have become corrupted due to the overwriting process.

9.4.2.4 Data Block

9.4.2.4.1 Data Mark

For track 00, Side 0, this field shall comprise:

6 (00)-bytes  
1 byte

The 7th byte shall be either:

(FB)\* indicating that the data is valid and that the whole Data Field can be read, or

(F8)\* indicating that the first byte of the Data Field shall be interpreted according to Standard ECMA-91, 130 mm Flexible Disk Cartridge Labelling and File Structure for Information Interchange.

For all other tracks this field shall comprise:

12 (00)-bytes  
3 (A1)\*-bytes  
1 byte

The 16th byte shall be either:

SECTION V

TRACK FORMAT No 2

(FB) indicating that the data is valid and that the whole Data Field can be read, or

(F8) indicating that the first byte of the Data Field shall be interpreted according to Standard ECMA-91, 130 mm Flexible Disk Cartridge Labelling and File Structure for Information Interchange.

#### 9.4.2.4.2 Data Field

This field shall comprise 128 bytes or 256 bytes as specified in sections 7.4.2 or 8.4.2.

If it comprises less than the requisite number of data bytes, the remaining positions shall be filled with (00)-bytes.

Data Fields in cylinder 00 are reserved for operating system use, including labelling.

#### 9.4.2.4.3 EDC

Description: see 7.4.3 and 8.4.3.

If the last byte of the Data Mark is (F8)\* or (F8) and the 1st character of the Data Field is CAPITAL LETTER F, the EDC may or may not be correct, as the sector contains a defective area; if the 1st character is CAPITAL LETTER D, then the EDC shall be correct.

On track 00, Side 0, only CAPITAL LETTER D is allowed.

#### 9.4.2.5 Data Block Gap

This field is recorded after each Data Block and it precedes the following Sector Identifier. After the last Data Block is preceded the Track Gap.

It comprises initially 27 (FF)-bytes (7.5) or 54 (4E)-bytes (8.5). These bytes may have become ill-defined due to overwriting process.

#### 9.4.2.6 Track Gap

Description: see 7.6 and 8.6.

### 9.5 Layout of the Tracks of a Bad Cylinder

#### 9.5.1 Contents of the fields

The fields of the tracks of a bad cylinder should have the following contents.

##### 9.5.1.1 Index Gap

Description: see 7.1 and 8.1.

##### 9.5.1.2 Sector Identifier

This field should comprise an Identifier Mark and an Address Identifier.

9.5.1.2.1 Identifier Mark

This field should comprise 16 bytes:

12 (00)-bytes  
3 (A1)\*-bytes  
1 (FE)-byte

9.5.1.2.2 Address Identifier

This field should comprise 6 bytes:

4 (FF)-bytes  
2 EDC-bytes

These two EDC-bytes shall be generated as defined in 6.1.14 using the bytes of the Sector Identifier starting with the first (A1)\*-byte (9.5.1.2.1) of the Identifier Mark and ending with the above 4 (FF)-bytes.

9.5.1.3 Other Fields

The contents of the remaining fields are not specified and may be ill-defined.

9.5.2 Requirements for tracks

Each track of a bad cylinder shall have at least one of its Sector Identifiers with the content specified in 9.5.1.2. If this condition is not satisfied the cartridge shall be rejected.

## TRACK FORMAT No 2

### 10. GENERAL REQUIREMENTS

#### 10.1 Mode of Recording

The mode of recording shall be Modified Frequency Modulation (MFM) for which the conditions are:

- a flux transition shall be written at the centre of each bit cell containing a ONE,
- a flux transition shall be written at each cell boundary between consecutive bit cells containing ZEROS.

Exceptions to this are defined in 10.12.

#### 10.2 Track Location Tolerance of the Recorded Flexible Disk Cartridge

The centrelines of the recorded tracks shall be within  $\pm 0,0425$  mm of the nominal position.

#### 10.3 Recording Offset Angle

At the instant of writing or reading a magnetic transition, the transition may have an angle  $\alpha = 0^\circ \pm 18'$  with the radius.

##### Note 6:

As tracks may be written and overwritten at extremes of the tolerances given in 10.2 and 10.3, a band of old information may be left at one edge of the newly written data and would constitute unwanted noise when reading. It is therefore necessary to trim the edges of the tracks by erasure after writing.

#### 10.4 Density of Recording

- 10.4.1 The nominal density of recording shall be 7958 ftprad. The resulting nominal bit cell length is 125,7 microradians.
- 10.4.2 The long-term average bit cell length shall be the average bit cell length measured over a sector. It shall be within  $\pm 3,5\%$  of the nominal bit cell length.
- 10.4.3 The short-term average bit cell length, referred to a particular bit cell, shall be the average of the lengths of the preceding eight bit cells. It shall be within  $\pm 8\%$  of the long-term average bit cell length.

#### 10.5 Flux Transition Spacing

The instantaneous spacing between flux transitions may be influenced by the reading and writing process, the bit sequence (pulse crowding effects) and other factors. The locations of the transitions are defined as the locations of the peaks in the signal when reading. Tests should be carried out using a peak-sensing amplifier (see Appendices D and E).

- 10.5.1 The spacing between the flux transitions of a sequence of ONES shall be between 80% and 120% of the short-term average bit cell length.
- 10.5.2 The spacing between the flux transition for a ONE and that between two ZEROS preceding or following it shall be between 130% and 165% of the short-term average bit cell length.



10.5.3 The spacing between the flux transitions of two ONES surrounding a ZERO shall lie between 185% and 225% of the short-term average bit cell length.

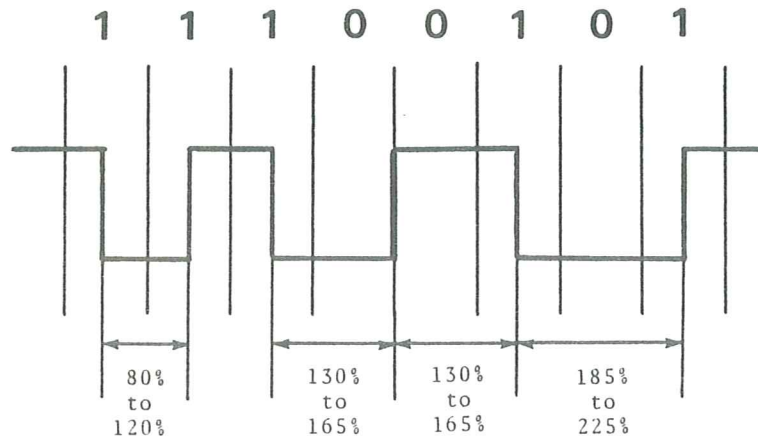

10.6 Average Signal Amplitude

For each side the Average Signal Amplitude on any track of the interchanged flexible disk cartridge shall be less than 160% of  $SRA_{1f}$  and more than 40% of  $SRA_{2f}$ .

10.7 Byte

A byte is a group of eight bit-positions, identified by  $B_1$  to  $B_8$ . The bit in each position is a ZERO or a ONE.

10.8 Sector

All tracks are divided into 9 sectors of 512 bytes.

10.9 Cylinder

A pair of tracks, one on each side, having the same track number.

10.10 Cylinder Number

The cylinder number shall be a two-digit number identical with the track number of the tracks of the cylinder.

10.11 Data Capacity of a Track

The data capacity of a Track shall be 4608 bytes.

10.12 Hexadecimal Notation

Hexadecimal notation shall be used hereafter to denote the following bytes:

(00)	for	( $B_8$ to $B_1$ )	=	00000000
(01)	for	( $B_8$ to $B_1$ )	=	00000001
(02)	for	( $B_8$ to $B_1$ )	=	00000010
(4E)	for	( $B_8$ to $B_1$ )	=	01001110
(FE)	for	( $B_8$ to $B_1$ )	=	11111110
(FB)	for	( $B_8$ to $B_1$ )	=	11111011
(A1)*	for	( $B_8$ to $B_1$ )	=	10100001

In byte (A1)\* the boundary transition between  $B_3$  and  $B_4$  is missing.

10.13 Error Detection Characters (EDC)

The two EDC bytes are hardware-generated by shifting serially the relevant bits, specified later for each part of the track, through a 16-bit shift register described by the generator polynomial:

$$X^{16} + X^{12} + X^5 + 1$$

(See also Appendix F).

11. TRACK LAYOUT

After formatting, there shall be 9 sectors on each track. During formatting the rotational speed of the disk, averaged index to index, shall be 300 rpm ± 6 rpm.

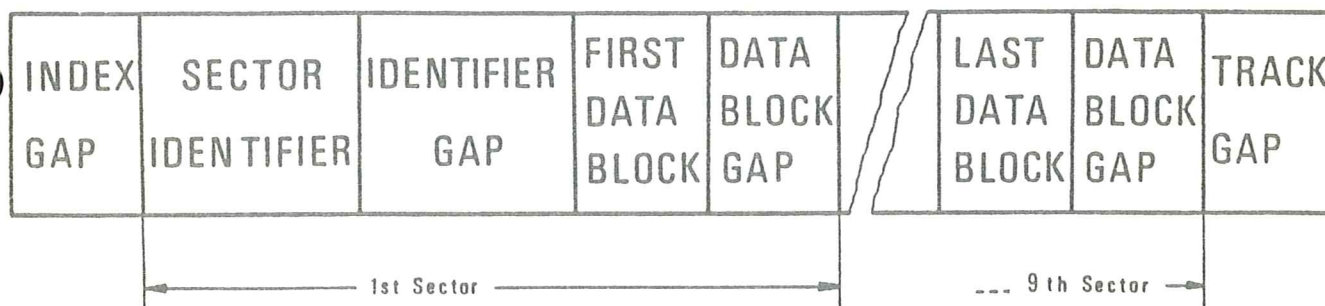

11.1 Index Gap

At nominal density, this field shall comprise at least 32 and at most 146 bytes of unspecified content (except that there shall be no (A1)\*-bytes). Writing the Index Gap is started when the Index is detected. Any of the first 16 bytes may have become ill-defined due to overwriting.

11.2 Sector Identifier

The layout of this field shall be as follows:

SECTOR IDENTIFIER							
IDENTIFIER MARK			ADDRESS IDENTIFIER				
12 Bytes (00)	3 Bytes (A1)*	1 Byte (FE)	TRACK ADDRESS		S	1 Byte (02)	EDC
			1 Byte (00)	Side 1 Byte (00) or (01)	1 Byte		1 Byte

11.2.1 Identifier Mark

This field shall comprise 16 bytes:

- 12 (00)-bytes
- 3 (A1)\*-bytes
- 1 (FE)-byte

### 11.2.2 Address Identifier

This field shall comprise 6 bytes.

#### 11.2.2.1 Track Address

This field shall comprise 2 bytes:

##### i) Cylinder Number (C)

This field shall specify in binary notation the cylinder number from 00 for the outmost cylinder to 79 for the innermost cylinder.

##### ii) Side Number (Side)

This field shall specify the side of the disk. On Side 0, it shall be (00) on all tracks. On Side 1 it shall be (01) on all tracks.

#### 11.2.2.2 Sector Number (S)

The 3rd byte shall specify in binary notation the sector number from 01 for the 1st sector to 09 for the last sector.

The sectors may be recorded in any order of their sector numbers.

#### 11.2.2.3 4th Byte

The 4th byte shall always be a (02)-byte.

#### 11.2.2.4 EDC

These two bytes shall be generated as defined in 10.13 using the bytes of the Sector Identifier starting with the first (A1)\*-byte (see 11.2.1) of the Identifier Mark and ending with the 4th byte (see 11.2.2.3) of the Address Identifier.

If the EDC is incorrect, then the sector is defective. The relevant standard for file structure and labelling specifies the handling of defective sectors.

### 11.3 Identifier Gap

This field shall comprise 22 initially recorded (4E)-bytes. These bytes may have become ill-defined due to overwriting.

### 11.4 Data Block

The layout of this field shall be as follows:

DATA BLOCK				
DATA MARK			DATA FIELD	EDC
12 Bytes (00)	3 Bytes (A1) <sup>SP</sup>	1 Byte (FB)	512 Bytes	2 Bytes

#### 11.4.1 Data Mark

This field shall comprise:

- 12 (00)-bytes
- 3 (A1)\*-bytes
- 1 (FB)-byte.

#### 11.4.2 Data Field

This field shall comprise 512 bytes.

If it comprises less than the requisite number of data bytes, the remaining positions shall be filled with (00)-bytes.

#### 11.4.3 EDC

These two bytes shall be generated as defined in 10.13 using the bytes of the Data Block starting with the first (A1)\*-byte of the Data Mark and ending with the last byte of the Data Field.

If the EDC is incorrect, then the sector is defective. The relevant standard for the file structure and labelling specifies the handling of defective sectors.

#### 11.5 Data Block Gap

This field shall comprise 80 initially recorded (4E)-bytes. These bytes may have become ill-defined due to overwriting. The Data Block Gap is recorded after each Data Block and it precedes the following Sector Identifier. After the last Data Block, it precedes the Track Gap.

#### 11.6 Track Gap

This field shall follow the Data Block Gap of the last sector. (4E)-bytes are written until the Index is detected, unless it has been detected during the writing of the last Data Block Gap, in which case there shall be no Track Gap.

### 12. CODED REPRESENTATION OF DATA

#### 12.1 Standards

The contents of the data field shall be recorded and interpreted according to the relevant international standards for the coding of information.

#### 12.2 Coding Methods

12.2.1 When the coding method requires it, the data field shall be regarded as an ordered sequence of 8-bit bytes.

Within each byte the bit positions shall be identified by  $B_8$  to  $B_1$ . The high-order bit shall be recorded in position  $B_1$ . The sequence of recording shall be high-order bit first.

When the data is encoded according to an 8-bit code, the binary weights of the bit positions shall be:

Bit Position	$B_8$	$B_7$	$B_6$	$B_5$	$B_4$	$B_3$	$B_2$	$B_1$
Binary Weights	128	64	32	16	8	4	2	1

When the data is encoded according to a 7-bit code, bit position  $B_8$  shall contain bit ZERO, and the data shall be encoded in bit position  $B_7$  to  $B_1$ , using the same binary weights as shown above.

- 12.2.2 When the coding method requires it, the data field shall be regarded as an ordered sequence of bit positions, each containing a bit.

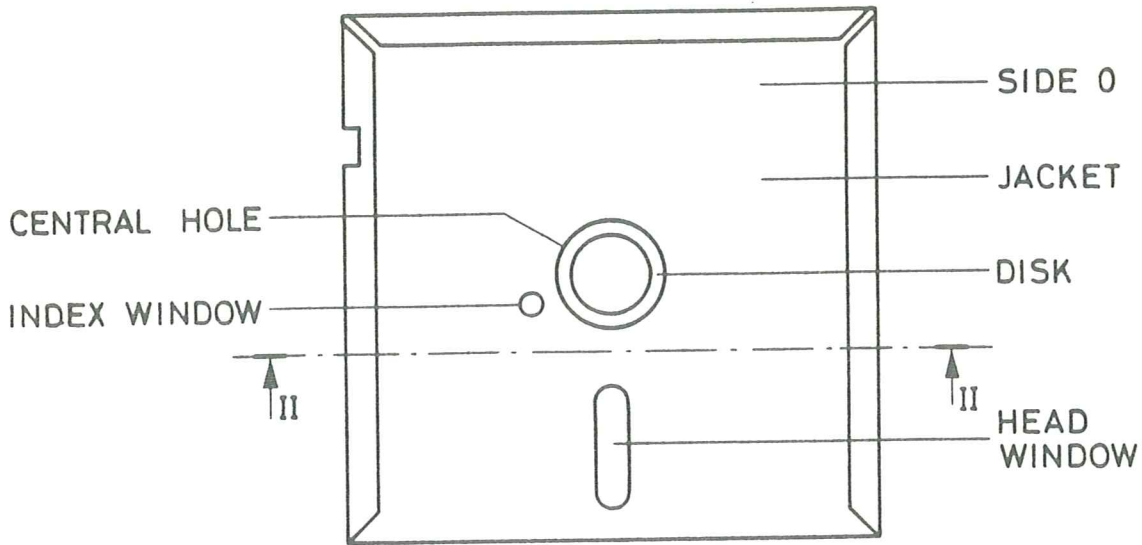

FIG. 1

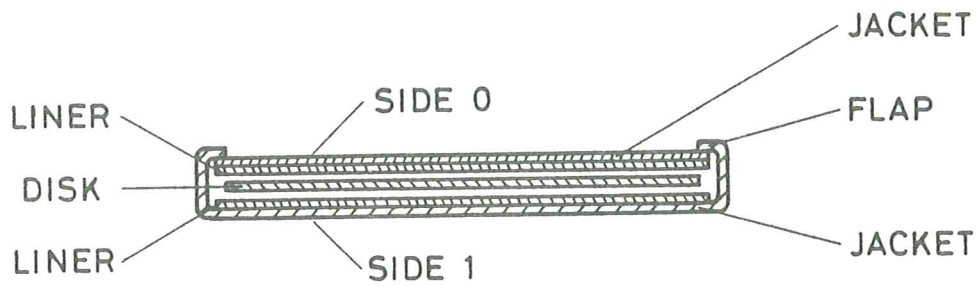

FIG. 2

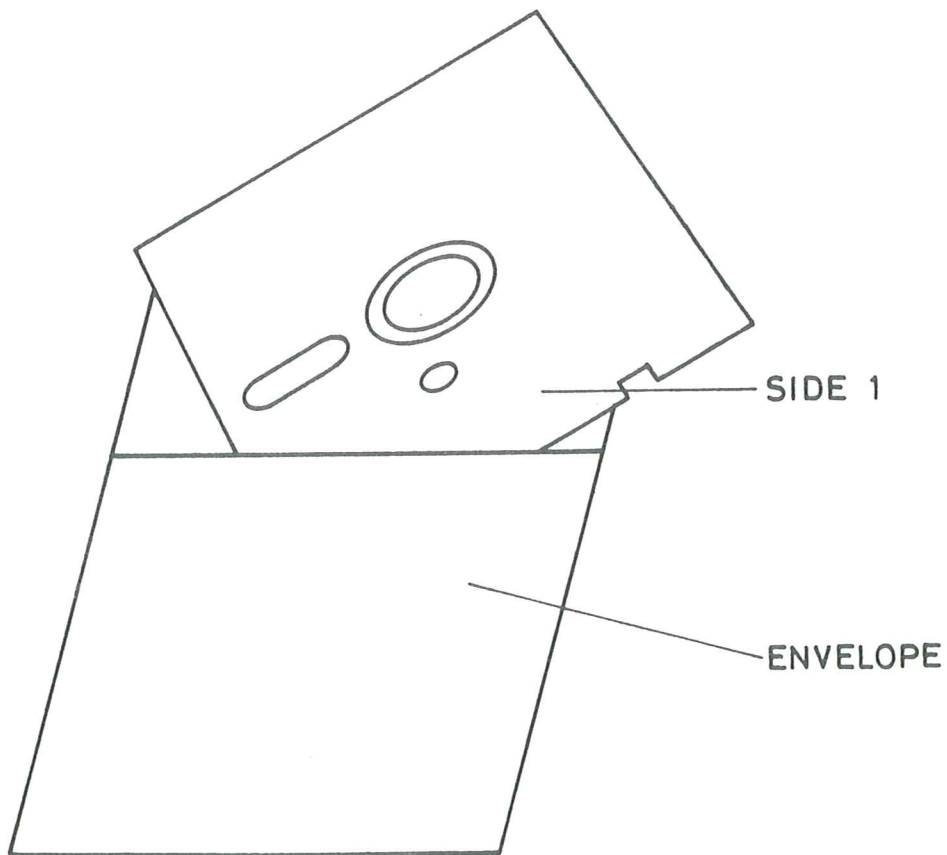

FIG. 3

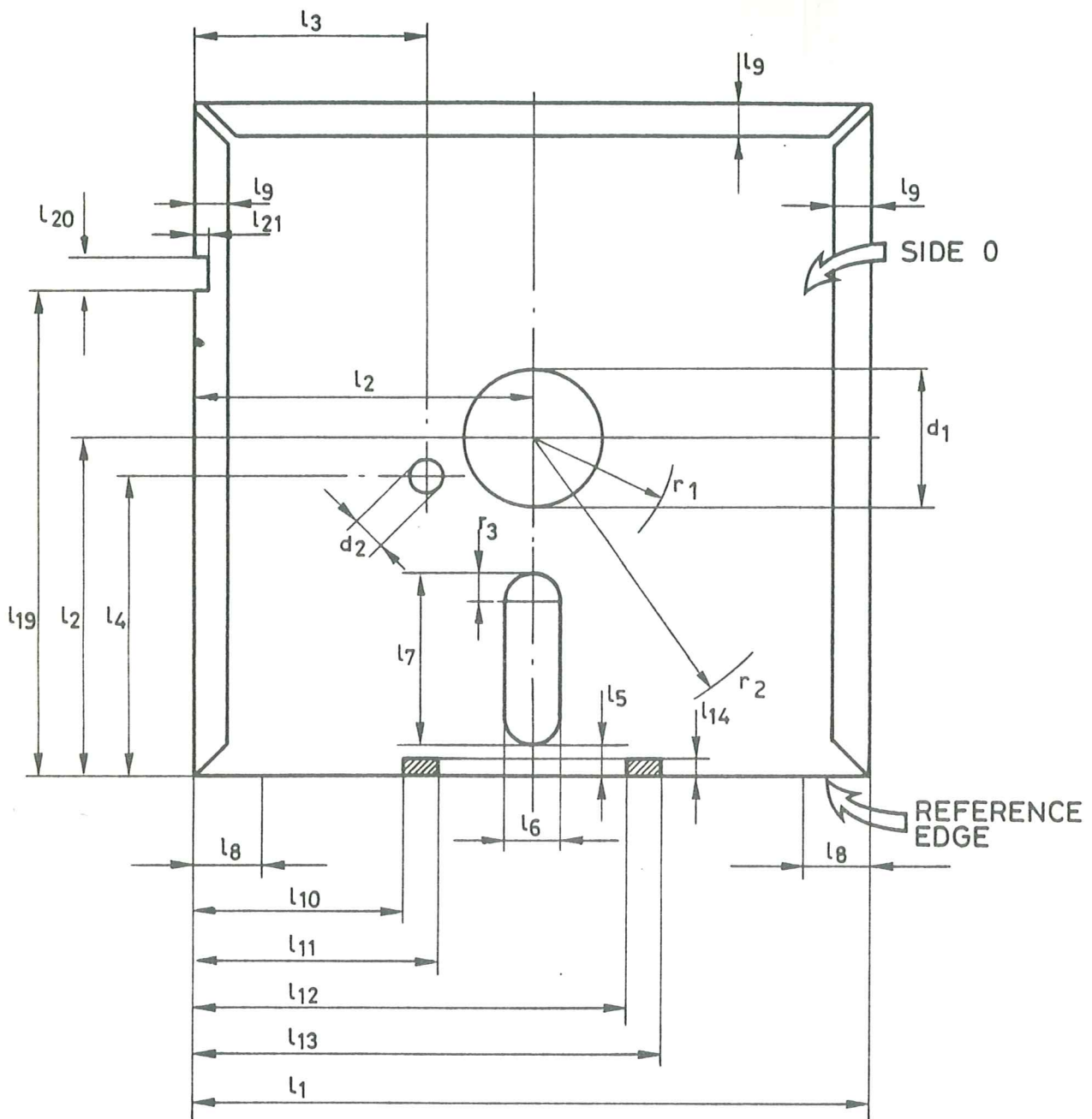

FIG. 4

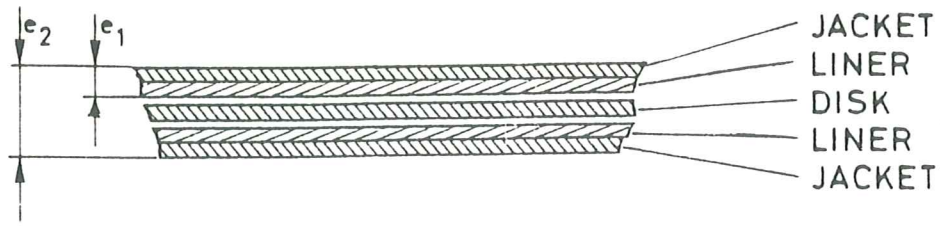

FIG. 5

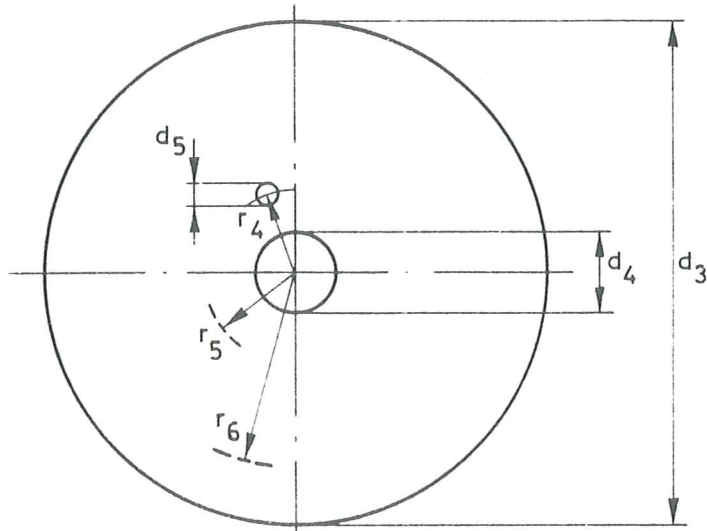

FIG. 6

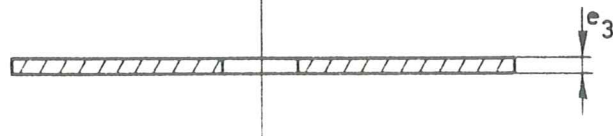

FIG. 7

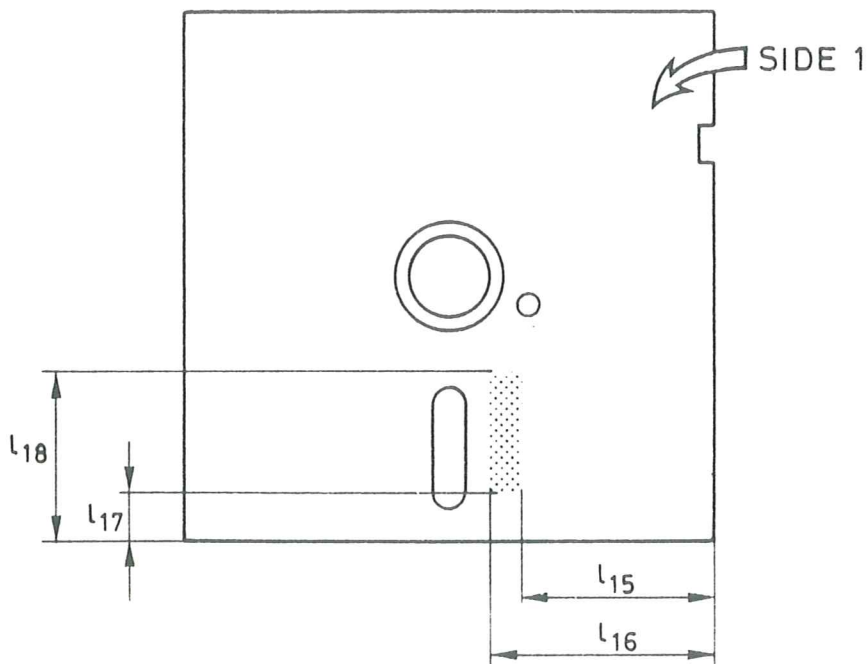

FIG. 8



APPENDIX A

MEASUREMENT OF THE CARTRIDGE THICKNESS

A.1 MAXIMUM THICKNESS

This value shall be measured for all edges using the gauge of Fig. 1. The cartridge must be capable of entering the gauge for at least 15 mm when a force of 1 N max is applied on the opposite edge.

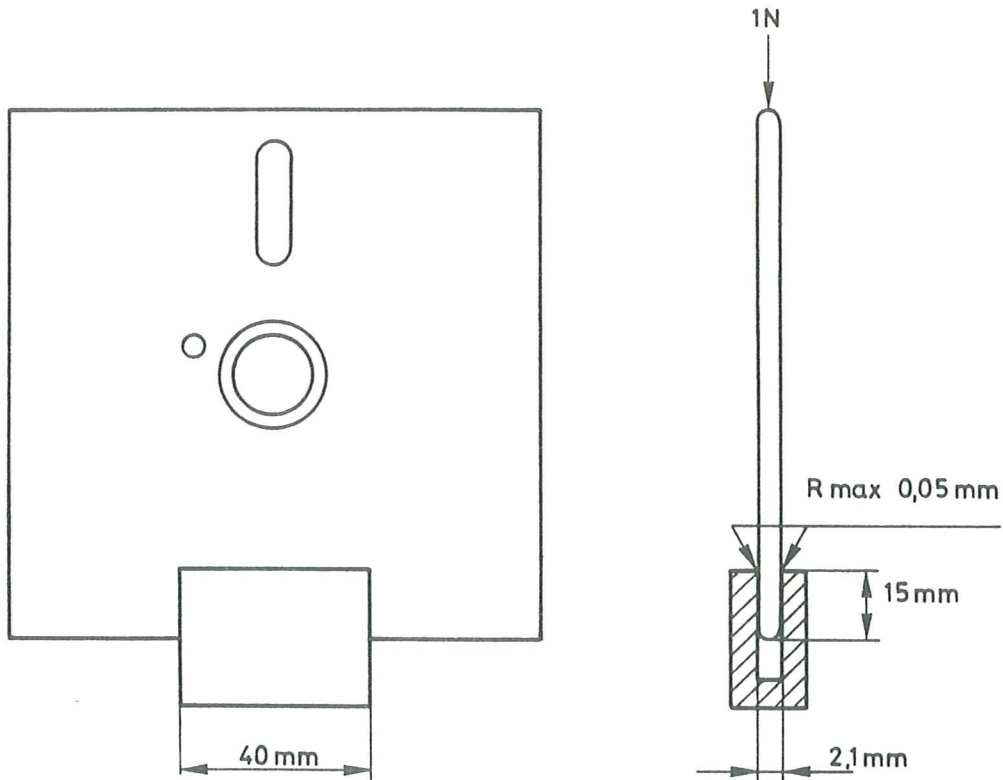
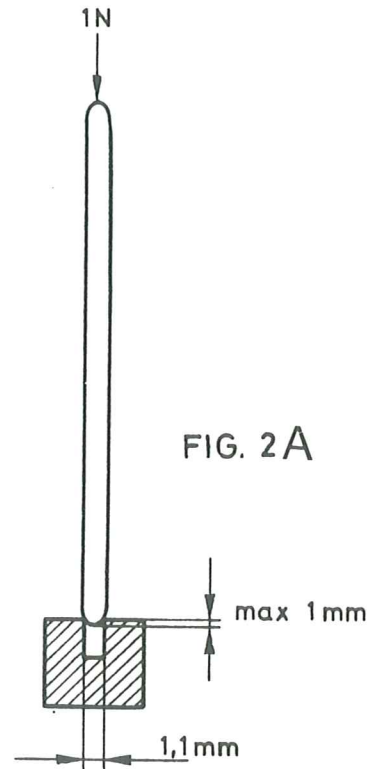

FIG. 1A

A.2 MINIMUM THICKNESS

This value shall be measured for all edges using the gauge of Fig. 2 of 40 mm. When submitted to a force of 1 N the cartridge shall enter the slot by less than 1 mm.



A.3 THICKNESS OF THE FLAPS (IF ANY)

This thickness shall be measured with the stylus of Fig. 3. The cartridge is placed on a horizontal surface with flaps opposite to the bottom surface.

The stylus is put on the flap, its axis being perpendicular to the cartridge edge. The stylus is loaded with a force of 1 N. The total thickness is measured with a dial gauge. The stylus is then moved radially to the nearest internal zone of the cartridge and the thickness is measured again. The difference between the two values measured is the contribution of the flap to the total thickness of the cartridge.

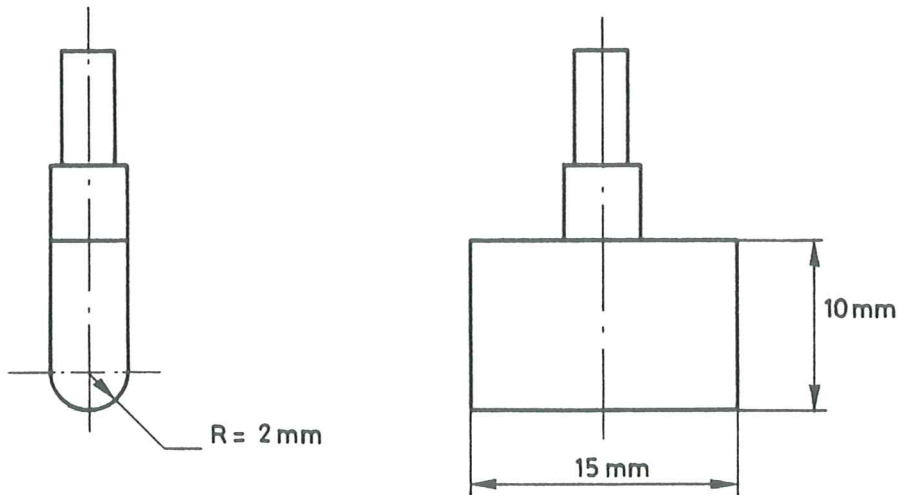

APPENDIX B

MEASUREMENT OF LIGHT TRANSMITTANCE

B.1 INTRODUCTION

The following description outlines the general principle of the measuring equipment and the measuring method to be applied when measuring the radiation (light) transmittance of the jacket and of the magnetic disk.

For the purpose of this document "light transmittance" is defined by convention as the relationship between the reading obtained when no sample is present. The transmittance value is expressed as the percentage ratio of the two readings. The essential elements of the measuring equipment are:

- the radiation source
- the photo diode
- the optical path
- the measuring circuitry.

B.2 DESCRIPTION OF THE MEASURING EQUIPMENT

B.2.1 Radiation Source

An infra red light-emitting diode (LED) with the following parameters shall be used:

Wavelength at peak emission	$\lambda_{\text{peak}} = 940 \text{ nm} \pm 10 \text{ nm}$
Half-power band width	$b = \pm 25 \text{ nm}$

Note B.1:

Earlier standards for unrecorded flexible disk cartridges required the use of an LED with a nominal wavelength of 900 nm, which is no longer available.

B.2.2 Radiation Receiver

A flat silicon photo diode shall be used as the radiation receiver. It shall be operated in the short circuit mode. The active area of the diode shall be equal to, or at the most 20% larger than, the open area of the aperture. This condition guarantees a linear dependency of the short circuit diode current on the light intensity.

B.2.3 Optical Path (Fig. 1 B)

The optical axis of the set up shall be perpendicular to the disk.

The distance from the emitting surface of the LED to the disk shall be:

$$L_1 = \frac{d_{\text{max}}}{2 \text{ tg } \alpha}$$

$d_{\max}$  is the maximum diameter of the index hole.

$\alpha$  is the angle where the relative intensity of the LED is equal to, or greater than, 95% of the maximum intensity in the optical axis.

The aperture shall have a thickness of 1,2 mm to 1,4 mm and a diameter given by:

$$D = (2 L_2 \operatorname{tg} \alpha) \text{ mm}$$

$$L_2 = (L_1 + 1,5) \text{ mm}$$

Its surfaces shall be matt black. The whole device should be enclosed within a light-tight casing.

#### B.2.4 Measuring Circuitry

Fig. 2 shows the recommended circuitry with the following components:

- E : regulated power supply with variable output voltage
- R : current-limiting resistor
- LED : light-emitting diode
- $D_i$  : Si photo diode
- A : operational amplifier
- $R_{f0}, R_{f1}$  : feedback resistors
- S : gain switch
- V : voltmeter

The forward current of the LED and consequently its radiation power can be varied by means of the power supply E.  $D_i$  is working in the short circuit mode. The output voltage of the operational amplifier is given by:

$$V_0 = I_k \cdot R_f$$

and is therefore a linear function of the light intensity.  $I_k$  is the short circuit current of  $D_i$ .

$R_{f0}$  and  $R_{f1}$  shall be low-temperature drift resistors with an accuracy of 1%. The following ratio applies:

$$\frac{R_{f0}}{R_{f1}} = \frac{1}{50}$$

### B.3 MEASURING METHOD

#### B.3.1 Measurement of the Disk

The measurements shall be taken within an annular band whose boundaries are tangent to the index hole.

- S is set to position 0. With the index hole in front of the photo diode, the voltmeter is set to full-scale reading (100% transmittance) by varying the output voltage of E.

- The disk is rotated until the photo diode is covered by the disk. S is set to position 1. Full deflection of the voltmeter now represents 2% transmittance.

The disk is rotated slowly for one revolution and the readings of the voltmeter are observed.

B.3.2. Measurements of the Jacket

The same procedure applies to the jacket measurement, except that the jacket without a disk must be rotated.

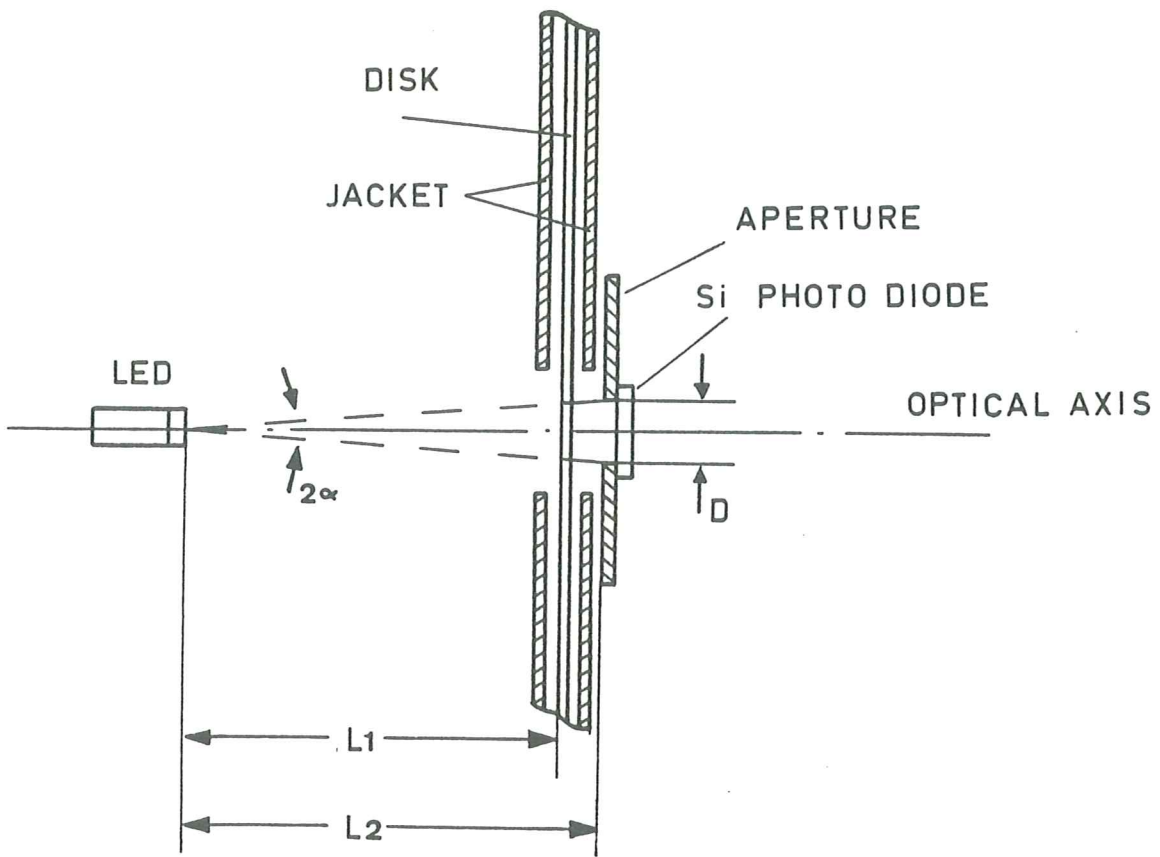

FIG. 1B MEASURING DEVICE

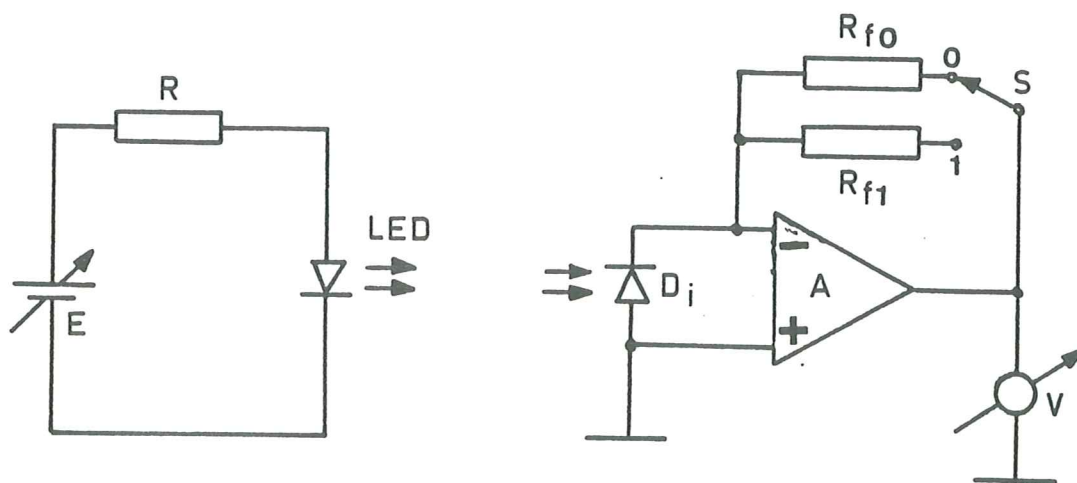

FIG. 2B ELECTRONIC CIRCUITRY

APPENDIX C

METHOD FOR MEASURING THE EFFECTIVE TRACK WIDTH

DC erase a 7-track wide band. Record 250 000 fps frequency patterns in a track centred in the middle of the erased band, with the erase element active. Measure the output voltage.

Move the head radially over the disk in increments not greater than 0,01 mm to the left and to the right until the read back signal has decreased by 75%. Determine the read back signal amplitude for each incremental move and plot its amplitude versus displacement. See figure below for reading the half track width A and B for both sides of displacement provided the gap width of the head used is not smaller than the effective track width. The total effective track width is the sum of A and B.

The test should be repeated to ensure that no thermal or hygroscopic effects have taken place during the measurement.

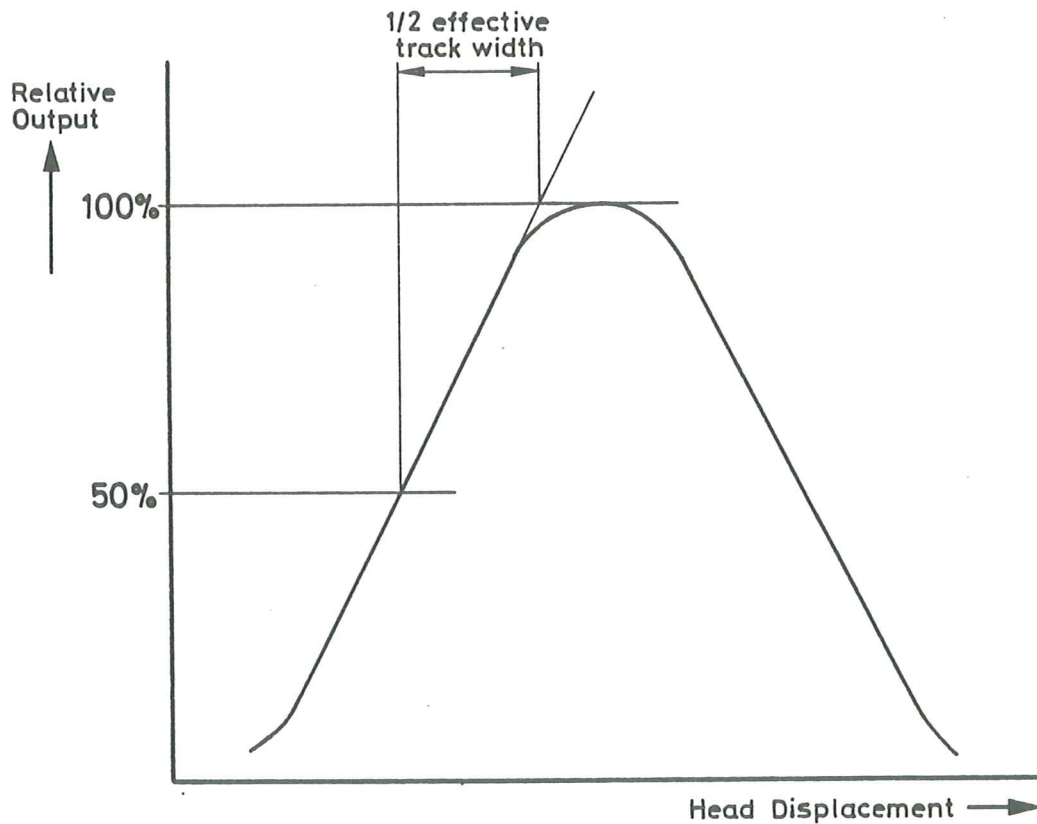

APPENDIX D

PROCEDURE AND EQUIPMENT FOR MEASURING FLUX TRANSITION SPACING

D.1 GENERAL

This Appendix specifies an equipment and a procedure for measuring flux transition spacing on 130 mm flexible disk cartridges using MFM recording at 13262 ftprad on both sides.

D.2 FORMAT

The disk to be measured shall be written by the disk drive for data interchange use.

Testing shall be done on tracks 00 and 79 on both sides.

D.2.1 Track Format No. 1

Track 00, Side 0 shall have the test patterns 00100000 (20) and 11101111 (EF) written repeatedly.

All other test tracks shall have the test patterns 11011011 (DB) and 11011100 (DC) written repeatedly.

D.2.2 Track Format No. 2

The test tracks shall have the test patterns 11011011 (DB) and 11011100 (DC) written repeatedly.

D.3 TEST EQUIPMENT

D.3.1 Disk Drive

The disk drive shall have a rotational speed of 300 rpm  $\pm$  3 rpm, averaged over one revolution. The average angular speed, taken over 64 ms, shall not deviate by more than 0,5% from the speed averaged over one revolution.

D.3.2 Head

D.3.2.1 Resolution

The head shall have an absolute resolution of 55% to 65% at track 78 on both sides, using the Reference Material RM 7487, applying the calibration factor of the Reference Material, and recording with the appropriate Test Recording Current.

The resonant frequency of the head shall be at least 250 000 Hz. The resolution shall not be adjusted by varying the load impedance of the head. The resolution shall be measured at the output of the amplifier defined in D.3.3.1.

D.3.2.2 Offset Angle

The head shall have a gap offset angle of  $0^\circ \pm 6'$  with the disk radius on the testing drive.



D.3.2.3 Contact

Care shall be taken that the heads are in good contact with the medium during the tests.

D.3.3 Read Channel

D.3.3.1 Read Amplifier

The read amplifier shall have a flat response from 1 000 Hz to 187 500 Hz within  $\pm 1$  dB, and amplitude saturation shall not occur.

D.3.3.2 Peak Sensing Amplifier

Peak sensing shall be carried out by a differentiator and limiting amplifier.

D.3.4 Time Interval Measuring Equipment

The time interval counter shall be able to measure a resolution of 4  $\mu$ s to at least 5 ns.

A triggering oscilloscope may be used for this purpose.

D.4 PROCEDURE FOR MEASUREMENT

D.4.1 Flux Transition Spacing Measurement

The transition locations shall be measured by the locations of the peaks in the signal when reading.

The flux transition spacing shall be measured by the pulse timing intervals after the read channel amplifier defined in D.3.3.

D.4.2 Flux Transition Spacing for Track 00, Side 0

Measure time intervals  $t_1$  to  $t_8$  as shown below.

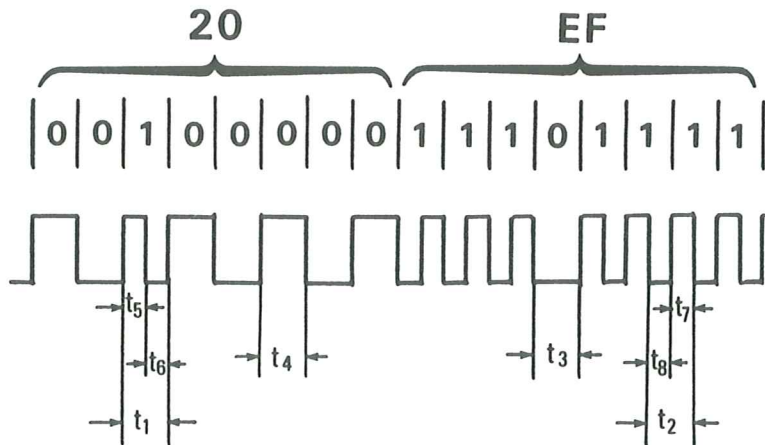

$t_1$  and  $t_2$  correspond to 6.5.1.1

$t_3$  and  $t_4$  correspond to 6.5.1.2

$t_5$ ,  $t_6$ ,  $t_7$  and  $t_8$  correspond to 6.5.1.3

D.4.3 Flux Transition Spacing for All Other Tracks

Measure time intervals  $t_1$  to  $t_5$  as shown below.

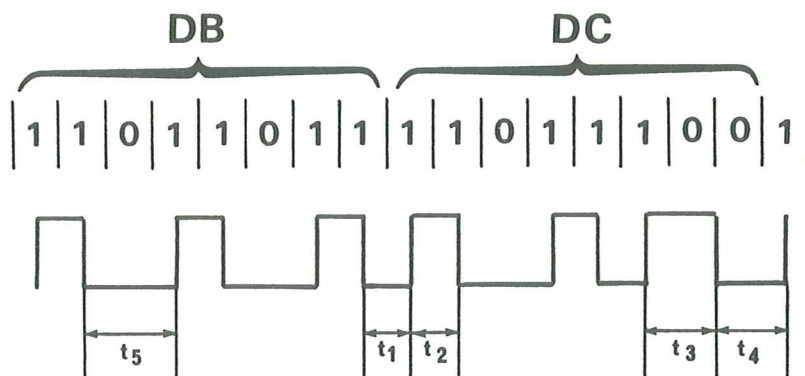

$t_1$  and  $t_2$  correspond to 6.5.2.1 and 10.5.1  
 $t_3$  and  $t_4$  correspond to 6.5.2.2 and 10.5.2  
 $t_5$  corresponds to 6.5.2.3 and 10.5.3.

APPENDIX E

DATA SEPARATORS FOR DECODING MFM RECORDING

E.1 On track 00, Side 0 the two-frequency recording results in nominal flux transition periods of:

t for a ONE cell  
2t for a ZERO cell

where  $t = 4 \text{ us}$

The data separator must be capable of resolving a difference of 4 us. This can be achieved satisfactorily by the use of a digital data separator, or one use using a fixed timer.

E.2 On all other tracks the MFM recording method gives nominal flux transitions spacing of:

t for the patterns 11 or 000  
 $3t/2$  for the patterns 10 or 01  
2t for the pattern 101

The data separator should be capable of resolving a difference on only 2 us. To achieve this with a low error rate the separator cannot operate on a fixed period but should follow changes in the bit cell length.

It is recognized that various techniques may be developed to achieve dynamic data separation; with present technology only an analogue data separator based on a phase-locked oscillator can provide the necessary reliability.

APPENDIX F

EDC IMPLEMENTATION

The figure below shows the feedback connections of a shift register which may be used to generate the EDC bytes.

Prior to the operation, all positions of the shift register are set to ONE. Input data are added (exclusive OR) to the contents of position  $C_{15}$  of the register to form a feedback. This feedback is in its turn added (exclusive OR) to the contents of position  $C_4$  and position  $C_{11}$ .

On shifting, the outputs of the exclusive OR gates are entered respectively into positions  $C_0$ ,  $C_5$  and  $C_{12}$ . After the last data bit has been added, the register is shifted once more as specified above.

The register then contains the EDC bytes.

If further shifting is to take place during the writing of the EDC bytes, the control signal inhibits exclusive OR operations.

To check for errors when reading, the data bits are added into the shift register in exactly the same manner as they were during writing. After the data the EDC bytes are also entered into the shift register as if they were data. After the final shift, the register contents will be all ZERO if the record does not contain errors.

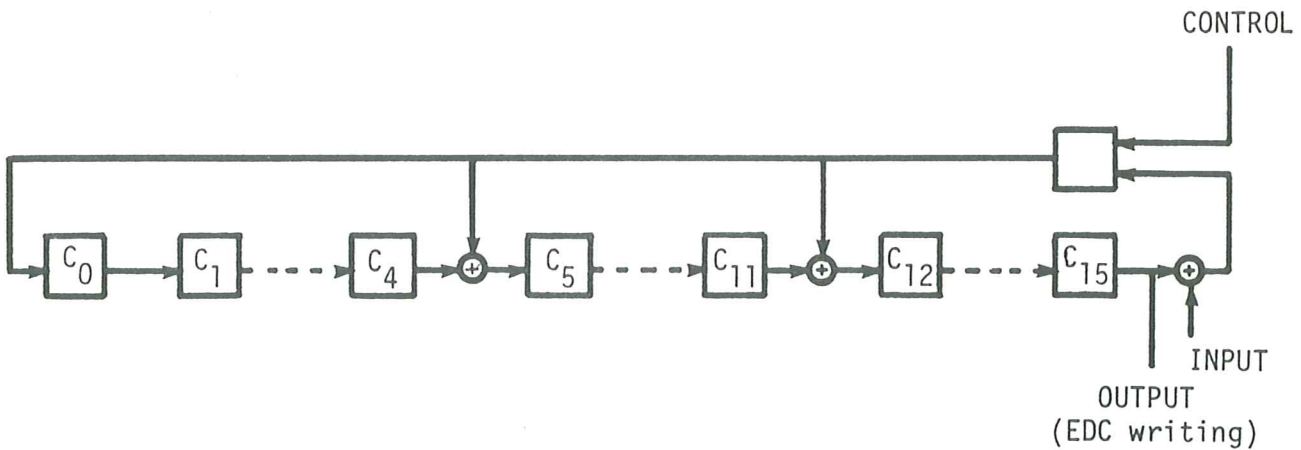

APPENDIX G

USE OF HUB SUPPORT RINGS

It is recognized that hub support rings are in common usage. Their use may improve or impair data interchange, according to the conditions of use.

Whether or not a hub support ring is fitted is a matter for agreement between the purchaser and the supplier. It is recommended that the hub support rings, if supplied, are fitted only by the original manufacturer of the flexible disk cartridge.

