

# ECMA

EUROPEAN COMPUTER MANUFACTURERS ASSOCIATION

---

STANDARD ECMA-95

INFORMATION  
TECHNOLOGY EQUIPMENT  
LIMITS OF INTERFERENCE  
AND  
MEASUREMENT METHODS

March 1985

Free copies of this document are available from ECMA,  
European Computer Manufacturers Association  
114 Rue du Rhône – 1204 Geneva (Switzerland)

# ECMA

EUROPEAN COMPUTER MANUFACTURERS ASSOCIATION

---

STANDARD ECMA-95

INFORMATION  
TECHNOLOGY EQUIPMENT  
LIMITS OF INTERFERENCE  
AND  
MEASUREMENT METHODS

March 1985

## BRIEF HISTORY

Technical Committee TC20 of ECMA was set up in 1972 to explore the conditions necessary to guarantee reciprocal electromagnetic compatibility between information technology equipment and the outside environment.

This Standard ECMA-95 is based on the work conducted in CISPR and on discussions between Industry and Regulatory Authorities. The methods of measurements and limits should ensure compliance with current requirements in various countries and with the corresponding Standard under approval in CISPR.

This Standard ECMA-95 replaces the ECMA Technical Report on the same subject (ECMA TR/12), that was published pending finalization of the work in CISPR.

This Standard ECMA-95 has been approved by the General Assembly of ECMA on December 13, 1984.

## TABLE OF CONTENTS

1. GENERAL	1
1.1 Introduction	2
1.2 Scope	2
1.3 References	3
1.4 Definitions	3
1.4.1 ITE	3
1.4.2 Test unit	3
1.4.3 Host unit	3
1.4.4 Identical modules and ITE	3
2. LIMITS	4
2.1 Limits of Mains Terminal Interference Voltage	5
2.1.1 Class A equipment	5
2.1.2 Class B equipment	5
2.2 Limits of Radiated Interference Field Strength	5
2.2.1 Class A equipment	6
2.2.2 Class B equipment	6
2.3 Interpretation of Limits	6
3. MEASUREMENT	7
3.1 General Measurement Conditions	8
3.1.1 Test site	8
3.1.2 Test unit configuration	8
3.1.3 Ground plane	9
3.2 Measurement of Terminal Voltage	9
3.2.1 Measuring receivers	9
3.2.2 Artificial mains network	9
3.2.3 Ground plane	11
3.3 Measurement of Radiated Interference Field Strength	11
3.3.1 Measuring receivers	11
3.3.2 Aerial	11
3.3.3 Measurement site	12
3.3.4 Measurement in presence of ambient signals	13
APPENDICES	
APPENDIX A: MEASUREMENT OF INTERFERENCE POWER	17
APPENDIX B: INTERFERENCE VOLTAGE ON TELECOMMUNICATION LINES	18

# 1 General

## 1. GENERAL

### 1.1 Introduction

Information technology equipment (ITE), which predominantly generates a multiplicity of periodic, binary pulsed electrical/electronic waveforms which can be unintentionally coupled via the mains cable, signal or other leads or by direct radiation, can constitute a potential source of interference to radio reception.

The limits and test methods contained in this Standard represent the result of exhaustive experiments and discussions between Industry and the Regulatory Authorities. This includes the harmonization of requirements for domestic DPE with those of other domestic appliances.

Having considered the present available technology, ECMA believes that this will provide an acceptable level of interference protection from Information Technology Equipment.

### 1.2 Scope

This Standard ECMA-95 applies to Information Technology Equipment (ITE) as defined in 1.4.1.

ITE is subdivided into two categories denoted Class A equipment and Class B equipment.

#### - Class A Equipment

Class A equipment is information technology equipment which satisfies the Class A interference limits but does not satisfy the Class B limits. In some countries, such equipment may be subject to restrictions on its sale and/or use.

#### NOTE 1

*The limits for Class A equipment are derived for typical commercial establishments for which a 30 m protection distance is used. The Class A limits may be too liberal for domestic establishments and some residential areas.*

#### - Class B Equipment

Class B equipment is information technology equipment which satisfies the Class B interference limits. Such equipment should not be subject to restrictions on its sale and is generally not subject to restrictions on its use.

#### NOTE 2

*The limits for Class B equipment are derived for typical domestic establishments for which a 10 m protection distance is used.*

Procedures are given for the measurement of the levels of spurious signals generated by the ITE and limits are specified for the frequency range 0,15 MHz - 1000 MHz for both Class A and Class B equipment.

### 1.3 References

In the body of this ECMA Standard reference is made to the following CISPR publications:

- CISPR Publication 16, Section One, Two and Five.
- CISPR Publication 16, Amendment no. 1.
- CISPR Recommendation 46/1.

### 1.4 Definitions

For the purpose of this Standard the following definitions apply.

#### 1.4.1 Information Technology Equipment (ITE)

Electrical/electronic units or systems which predominantly generate a multiplicity of periodic binary pulsed electrical/electronic wave forms and are designed to perform functions such as electronic word processing, electronic computation, data transformation, recording, filing, sorting, storage, retrieval and transfer, and reproduction of data and/or images.

#### 1.4.2 Test unit

A representative ITE or functionally interactive group of ITE (i.e. a system) which includes one or more host unit(s) and is used for evaluation purposes.

#### 1.4.3 Host unit

Part of an ITE system or unit that provides the mechanical housing for modules, which may contain radio frequency sources, and may provide power distribution to other ITE. Power distribution may be ac, dc, or both between the host unit(s) and modules or other ITE.

#### 1.4.4 Module

Part of an ITE which provides function and may contain radio frequency sources.

#### 1.4.5 Identical modules and ITE

Modules and ITE produced in quantity and within normal manufacturing tolerances to a given manufacturing specification.



## 2 Limits

## 2. LIMITS

### 2.1 Limits of Mains Terminal Interference Voltage

The test unit shall meet both the average limit and the quasi-peak limit when using, respectively, an average detector receiver and a quasi-peak detector receiver and measured in accordance with the methods described in 3.2. If the average limit is met when using a quasi-peak detector receiver, the test unit shall be deemed to meet both limits and measurement with the average detector receiver is unnecessary. The reading on the measuring receiver shall be observed for at least 15 s at each measurement frequency; the highest readings shall be recorded with the exception of any isolated spike which shall be ignored.

#### 2.1.1 Class A equipment

The limits defined in the table below apply to Class A equipment for mains terminal interference voltage in the frequency range 0,15 MHz to 30 MHz. The lower limit shall apply at the transition frequency.

Frequency Range (MHz)	Limits (dB/uV)	
	Quasi-peak	Average
0,15 to 0,50	79	66
0,50 to 30	73	60

Table 1

#### 2.1.2 Class B equipment

The limits defined in the table below apply to Class B equipment for mains terminal interference voltage in the frequency range 0,15 MHz to 30 MHz. The lower limit shall apply at the transition frequencies.

Frequency Range (MHz)	Limits (dB/uV)	
	Quasi-peak	Average
0,15 to 0,50	66 to 56	56 to 46
0,50 to 5	56	46
5 to 30	60	50

Table 2

#### NOTE 3

*The limit decreases linearly with the logarithm of the frequency in the range 0,15 MHz to 0,50 MHz.*

### 2.2 Limits of Radiated Interference Field Strength

The reading on the measuring receiver shall be observed for at least 15 s at each measurement frequency; the highest readings shall be recorded with the exception of any isolated spike which shall be ignored.

### 2.2.1 Class A equipment

The limits defined in the table below apply to Class A equipment for radiated interference field strength in the frequency range 30 MHz to 1000 MHz at a test distance of 30 m. The lower limit shall apply at the transition frequency.

Frequency Range (MHz)	Quasi-peak Limits (dB(uV/m))
30 to 230	30
230 to 1000	37

Table 3

#### NOTE 4

*If the field strength measurement at 30 m cannot be recorded because of high ambient noise levels or for other reasons, measurement may be made at a closer distance (see 3.3.2.2).*

#### NOTE 5

*Additional provisions may be required for cases where interference occurs.*

### 2.2.2 Class B equipment

The limits defined in the table below apply to Class B equipment for radiated interference field strength in the frequency range 30 MHz to 1000 MHz at a test distance of 10 m. The lower limit shall apply at the transition frequency.

Frequency Range (MHz)	Quasi-peak Limits (dB(uV/m))
30 to 230	30
230 to 1000	37

Table 4

#### NOTE 6

*If the field strength measurement at 10 m cannot be recorded because of high ambient noise levels or for other reasons, measurement may be made at a closer distance (see 3.3.2.2).*

#### NOTE 7

*Additional provisions may be required for cases where interference occurs.*

### 2.3 Interpretation of Limits

The significance of the limits defined in this ECMA Standard shall be such that on a statistical basis at least 80% of the mass produced equipment complies with the limits with at least 80% confidence. Reference is also made to CISPR Recommendation 46/1.

### 3 Measurement

### 3. MEASUREMENT

#### 3.1 General Measurement Conditions

##### 3.1.1 Test site

A test site shall permit emanations from the test unit to be distinguished from ambient noise. The suitability of the site in this respect can be determined by measuring the ambient noise levels with the test unit inoperative and ensuring that the noise levels are at least 6 dB below the specified limit.

It is not necessary to reduce the ambient noise level to 6 dB below the specified limit where both ambient noise and source emanation combined do not exceed the specified limit. The source emanation is then considered to satisfy the specified limit. Where the combined ambient noise and source emanation exceed the specified limit it must be demonstrated that, at any measurement frequency, two conditions be met:

- The ambient noise level is at least 6 dB below the source plus ambient conditions.
- The ambient noise level is at least 4,8 dB below the specified limit.

##### 3.1.2 Test unit configuration

An attempt shall be made to maximize the radiation consistent with the typical applications by varying the configuration of the test sample. Interface cables shall be connected to the available interface ports of the test unit. This includes, but is not limited to, standard interface bus ports provided on computers and peripherals. The effect of varying the position of the cables shall be investigated to find the configuration that produces maximum emission. The configuration shall be precisely noted in the test report.

Interconnecting cables should be of the type and length specified in the individual equipment requirements. If the length can be varied, the length shall be selected to produce maximum emission.

If shielded or special cables are used during the tests to achieve compliance, then a note must be included in the instruction manual advising of the need to use such cables.

Excess lengths of cables shall be bundled at the approximate centre of the cable with the bundles 30 cm to 40 cm in length. If it is impractical to do so because of the cable bulk or stiffness, or because the testing is being done at a user installation, the disposition of the excess cable shall be precisely noted in the test report.

Where there are multiple interface ports all of the same type, connecting a cable to just one of that type of port is sufficient provided it can be shown that the additional cables would not significantly affect the results.

Any set of results must be accompanied by a complete description of the cable and equipment orientation so that results can be repeated. If there are conditions of use, those conditions must be specified and documented; e.g. cable length, cable type, shielding and grounding. These conditions shall be included in the instructions to the user.

One module of each type shall be operative in each ITE evaluated

in a test unit, and for system test units, one of each type of ITE that can be included in the possible system configuration shall be included in the test unit. Following this procedure will permit the results of an evaluation of test units having one of each type of module or ITE to be applied to configurations having more than one of each of those modules or ITE. This is permissible because it has been found that emanations from identical (see 1.4.5) modules or ITE are, in practice, generally not additive.

In the case of test units which functionally interact with other ITE, including any ITE that is dependent on a host unit for its power interface, either the actual interfacing ITE or simulators may be used to provide representative operating conditions provided the effects of the simulator can be isolated or identified. If an ITE is designed to be a host unit to other ITE, such ITE may have to be connected in order that the host unit shall operate under normal conditions.

It is important that any simulator used in lieu of an actual interfacing ITE, properly represent the electrical and in some cases the mechanical characteristics of the interfacing ITE, especially r.f. signals and impedances. Following this procedure will permit the results of measurements of individual ITE to remain valid for system application and integration of the ITE with other similarly tested ITE, including ITE produced and tested by different manufacturers.

### 3.1.3 Ground plane

The test unit's relation to a ground plane shall be equivalent to that occurring in use, i.e. floor standing equipment resides on a ground plane or on an isolating floor (e.g. wood) close to a ground plane, and portable equipment resides on a non-metallic table. The ground plane may be of metal. The power and signal cables shall be oriented to the ground plane in a manner equivalent to actual use.

#### NOTE 8

*Specific ground plane requirements are given in 3.2.3 for terminal voltage measurements and in 3.3.3.2 for field strength measurements.*

## 3.2 Measurement of Terminal Voltage

### 3.2.1 Measuring receivers

Measurements shall be carried out using quasi-peak and average detector receivers described below. Both detectors may be incorporated in a single receiver and measurements carried out by alternately using the quasi-peak detector and the average detector.

Receivers with quasi-peak detectors shall be in accordance with CISPR Publication 16, Section One. Receivers with average detectors shall be in accordance with CISPR Publication 16, Section Five, clause 23.

### 3.2.2 Artificial mains network

An artificial mains network is required to provide a defined impedance at high frequencies across the power feed at the point of measurement of terminal voltage and also to provide isolation of the circuit under test from the ambient radio frequency energy

on the power lines.

A network with a nominal 50 Ohm impedance as defined in CISPR Publication 16, Section Two, sub-clause 8.3.3 shall be used.

Connection of the test unit to the artificial mains network is required and the test unit is located so that the distance between the boundary of the test unit and the closest surface of the artificial mains network is 0,8 m.

Where a mains flexible cord is provided by the manufacturer this shall be 1 m long or if in excess of 1 m the excess cable is folded back and forth as far as possible so as to form a bundle not exceeding 0,4 m in length.

Where a mains cable is specified in the manufacturer's installation instructions, a 1 m length of the type specified shall be connected between the test unit and the artificial mains network.

The test unit shall be arranged and connected with cables terminated in accordance with the manufacturer's instructions.

Earth connections, where required for safety purposes, shall be connected to the reference earth point of the network and where not otherwise provided or specified by the manufacturer shall be 1 m long and run parallel to the mains connection at a distance of not more than 0,1 m from it.

Other earth connection (e.g. for EMC purposes) and either specified or supplied by the manufacturer for connection to the same ultimate terminal as the safety earth connection, shall also be connected to the reference earth of the network.

It may not be possible to measure at some frequencies because of conducted ambient noise which couples from local broadcast service fields. A suitable additional radio frequency filter may be inserted between the artificial mains network and the mains supply, or measurements may be performed in a shielded enclosure. The components forming the additional radio frequency filter should be enclosed in a metallic screen directly connected to the reference earth of the measuring system. The requirements for the impedance of the artificial mains network should be satisfied, at the frequency of the measurement, with the additional radio frequency filter connected.

Where the test unit is a collection of ITE with one or more host units and ITE each having its own power cord, the point of connection for the artificial mains network referred to in 3.2.2 is determined from the following rules:

- Each power cord which is terminated in a mains supply plug of a standard design (IEC 83 for example) shall be tested separately.
- Power cords or terminals which are not specified by the manufacturers to be connected via a host unit shall be tested separately.
- Cords or field wiring terminals of an ITE which are specified by the manufacturer to be connected via a host unit or other power supplying equipment shall be connected to that host unit or other power supplying equipment and the terminals or cord of that host unit or other power supplying equipment are those considered for connection to the artificial mains network and tested.
- Where a special connection is specified the necessary hardware to effect that connection shall be supplied by the manufacturer for the purpose of this test.

### 3.2.3 Ground plane

The test unit, if unearthed and non-floor-standing shall be placed 0,4 m from a reference ground plane consisting of a horizontal or vertical metal surface of at least 2 m by 2 m and shall be kept at least 0,8 m from any other metal surface or other ground plane not being part of the test unit. If the measurement is made in a screened enclosure, the distance of 0,4 m may be referred to one of the walls of the enclosure.

Floor-standing test units are subject to the same provisions with the exception that they shall be placed on a floor, the point(s) of contact being consistent with normal use. The floor may be of metal but must not make metallic contact with the floor supports of the test unit(s). A metal floor may replace the reference ground plane.

The reference ground plane shall extend at least 0,5 m beyond the boundaries of the test unit and have minimum dimensions of 2 m by 2 m.

The reference ground plane shall be connected to the reference earth point of the artificial mains network with a conductor as short as possible.

### 3.3 Measurement of Radiated Interference Field Strength

Measurements of the radiated field shall be made at a distance measured from the boundary of the test unit. The boundary is defined by an imaginary straight line periphery describing a simple geometric configuration encompassing the test unit. All ITE inter-system cables and connecting ITE shall be included within this boundary (see also Figure 2).

The specific measurement distances for Class A and Class B ITE are given in 2.2.

#### 3.3.1 Measuring receivers

Measurements shall be conducted with a quasi-peak detector instrument in the frequency range of 30 MHz to 1000 MHz.

The measuring receiver shall be in accordance with the requirements of CISPR Publication 16, Section One.

#### 3.3.2 Aerial

##### 3.3.2.1 Aerial characteristics

The aerial shall be a balanced dipole. For frequencies of 80 MHz or above, the aerial shall be resonant in length and for frequencies below 80 MHz it shall have a length equal to the 80 MHz resonant length. Further detailed information is given in CISPR Publication 16, Amendment No 1.

##### NOTE 9

*Other aerials may be used, provided the results can be correlated with the balanced dipole aerial with an acceptable degree of accuracy.*

##### 3.3.2.2 Aerial-to-test unit distance

The aerial shall preferably be located at the horizontal distance from the test unit as specified in 2.2.1 and 2.2.2.



NOTE 10

An inverse proportionality factor of 20 db/decade shall be used to normalize the measured data to the specified distance for determining compliance.

3.3.2.3 Aerial-to-ground distance

The maximum distance between the centre of the aerial and ground shall be in accordance with the table below. The aerial shall be adjusted between 1 m and 4 m for maximum indication at each test frequency.

Aerial to test unit horizontal distance	Aerial to ground distance (max.)
3 m to 10 m 10 m to 30 m	1,5 m to 4 m (linear) 4 m

Table 5

3.3.2.4 Aerial-to-test unit azimuth and polarization

Aerial-to-test unit azimuth and polarization (horizontal and vertical) shall also be varied during the measurements to find the maximum field strength readings. For measurement purposes it may be possible to rotate the test unit. When this is not practicable the test unit remains in a fixed position and measurements are made around the test unit.

3.3.3 Measurement site

3.3.3.1 Test site

The test site for ITE shall characteristically be flat, free of overhead wires and nearby reflecting structures, sufficiently large to permit aerial placement at the specified distance and provide adequate separation between aerial, test unit and reflecting structures. One such test site is depicted in Figure 1.

3.3.3.2 Ground plane

Floor-standing test units shall be placed as close as possible to the ground plane of the test site. Portable test units shall be placed on a non-metallic table 0,8 m above the ground plane. A metal ground plane shall be inserted under the test unit on the natural ground plane and it must extend at least 1 m beyond the perimeter of the test unit at one end and at least 1,0 m beyond the measurement aerial and its supporting structure at the other end (see Figure 3). The ground plane shall have no voids or gaps that are a significant part of a wavelength at the highest frequency. The recommended maximum mesh size for screen or extended metal planes is about 30 mm at 1000 MHz.

3.3.3.3 Alternative sites

In some cases it may be necessary to conduct tests at sites that do not have all the characteristics described in 3.3.3.1. Evidence must be obtained that the errors due to such alternative sites shall not invalidate the results obtained. Figure 2 is an example of an alternative site. A ground plane

not satisfying all the requirements of 3.3.3.1 is another example.

#### 3.3.3.4 User installation testing

In some cases measurements of Class A ITE at the user's installation might be necessary. These measurements shall be made preferably at the boundary of the user's premises, or if such boundary is less than 30 m from the test unit, the measurements shall be made at a distance of 30 m from the test unit.

This form of compliance verification is unique to the installation site since the site containment properties affect the measurement. Additional type tested and compliant ITE could be added to the test unit without invalidating the compliance status of the final site in which the test unit was previously tested.

#### 3.3.4 Measurement in presence of ambient signals

In general, the ambient signals should not exceed the limit. Radiated emanations from the test unit at the point of measurement may, however, be impossible to measure at some frequencies due to ambient noise fields generated by local broadcast services, other man-made devices, and natural sources. If the ambient signal field strength is high at the specified distance, the following methods may be used to show compliance of the test unit.

- Perform measurements at close-in distances.
- Adjust the specified limit  $L_1$  at limit distance  $d_1$  to the close-in distance  $d_2$  as follows, where  $L_2$  is the adjusted limit.

$$L_1/L_2 = d_2/d_1$$

( $L_1$  and  $L_2$  are expressed in fundamental units of  $\mu\text{V/m}$ ).

Determine permissible ambient and pass/fail conditions stipulated in 3.1 using  $L_2$  as the new limit for distance  $d_2$ .

- Alternatively, the method referred to in CISPR. Publication 16, Sub-clause 19.2 (h) may be used.

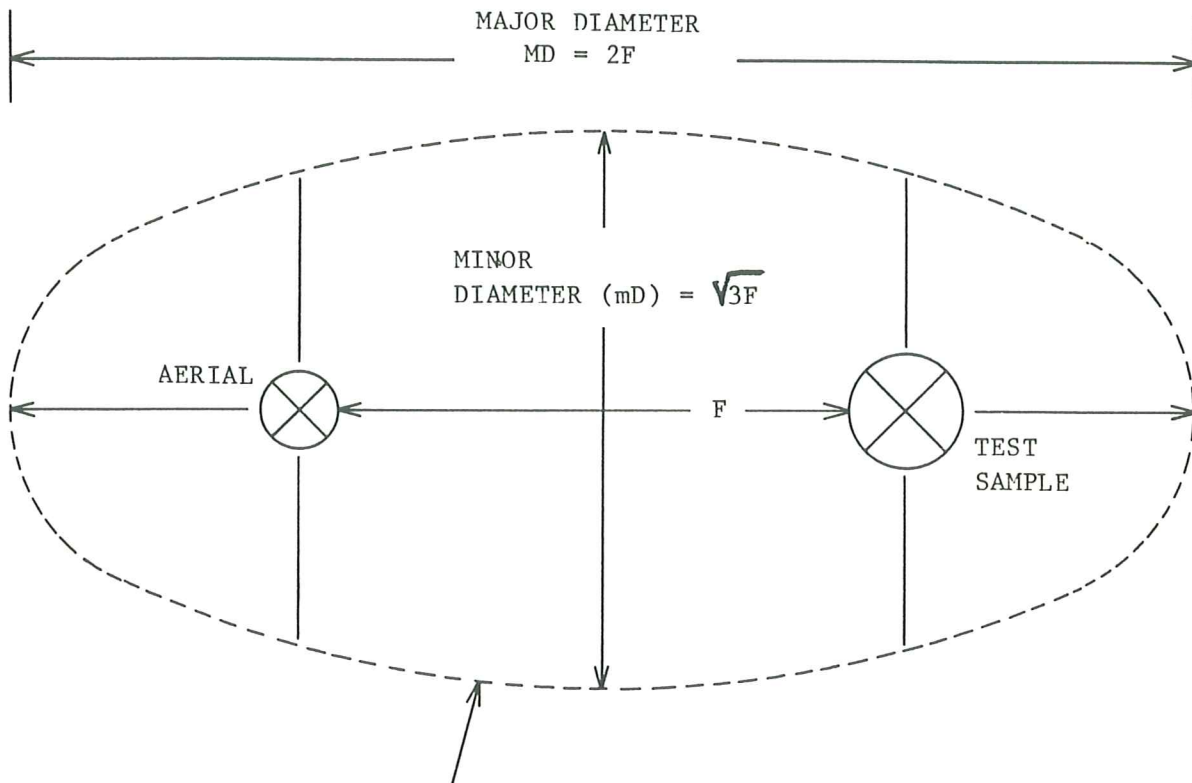

Boundary of area defined by an ellipse. Volume above earth to be free of reflecting objects.

*NOTE: Characteristics of test site further described in 3.1.1. See also 2.2.1 and 2.2.2 for the value or values of F.*

Fig. 1 - Test Site

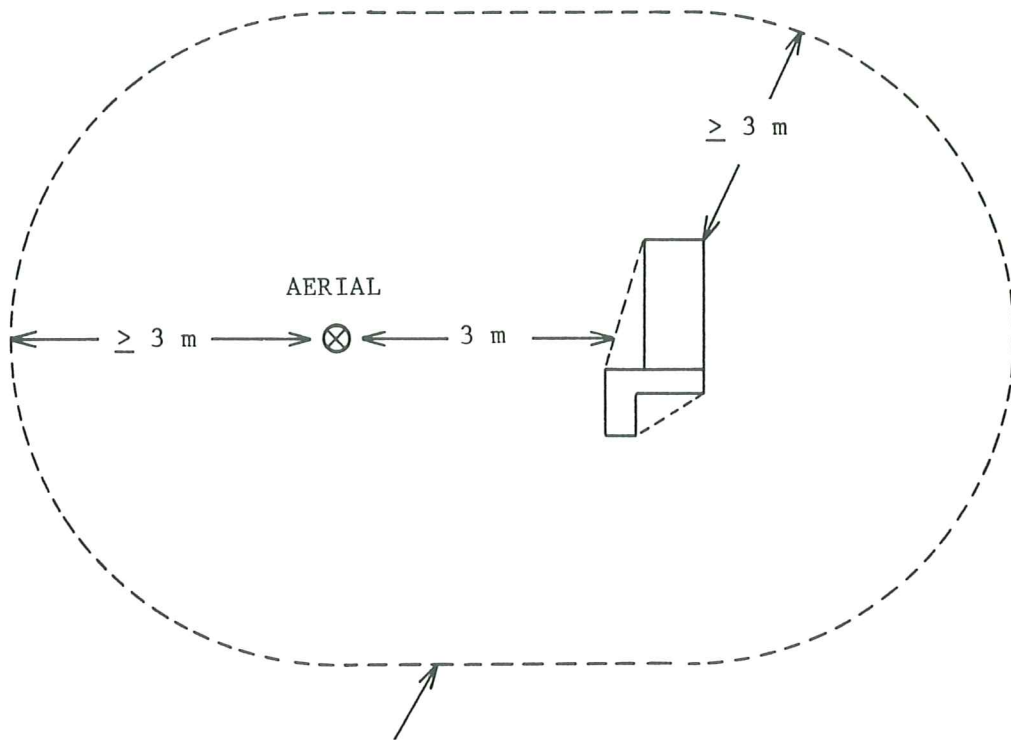

Surrounding boundary. Volume above earth to be free of reflecting objects  $\geq 3$  m above the test sample or aerial, whichever is greater.

*NOTE: See also 3.3.3.3 for applicability of the alternate test site. Also, the peripheral string method is described in 3.3.*

Fig. 2 - Minimum Alternative Measurement Site

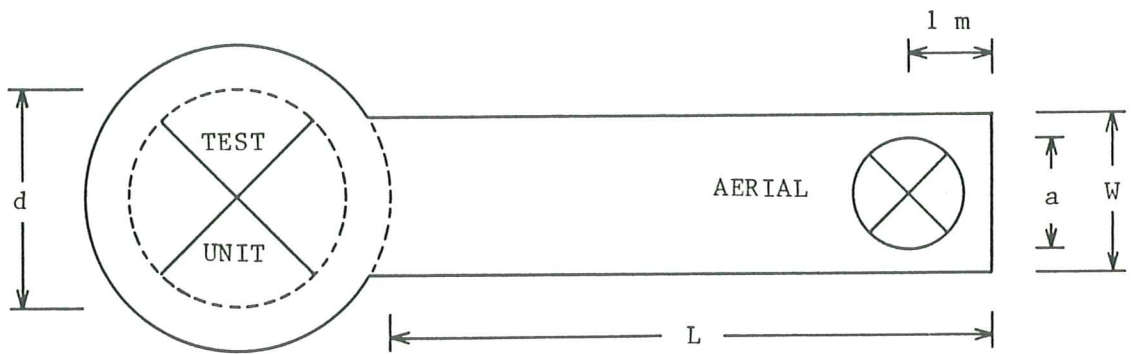

$D = d + 2\text{ m}$ , where  $d$  = maximum test unit dimension

$W = a + 1\text{ m}$ , where  $a$  = maximum aerial dimension

$L = 3\text{ m}$  or  $20\text{ m}$  or  $30\text{ m}$

Fig. 3 - Minimum Size of Metal Ground Plane

APPENDIX A

MEASUREMENT OF INTERFERENCE POWER

Some national authorities believe that, in the case of Class B equipment the measurement of, and limits for interference power is more suitable for regulatory and control purposes than is the measurement of, and limits for field strength of the interference. Therefore, the measurement of interference power for ITE is under consideration.

NOTE

*Those countries which already have provisions for using the absorbing clamp in their national standards may continue to include those provisions while the subject remains under consideration in CISPR Subcommittee B.*

APPENDIX B

INTERFERENCE VOLTAGE ON TELECOMMUNICATION LINES

The limits and measurement methods for interference voltage on Telecommunication lines are under consideration.

