

# ECMA

EUROPEAN COMPUTER MANUFACTURERS ASSOCIATION

---

**PLANNING AND INSTALLATION GUIDE  
FOR CSMA/CD 10 Mbit/s BASEBAND LAN  
COAXIAL CABLE SYSTEMS**

---

**ECMA TR/26**

**Second Edition June 1990**

Free copies of this document are available from ECMA,  
European Computer Manufacturers Association  
114 Rue du Rhône - CH-1204 Geneva (Switzerland)

Phone: +41 22 735 36 34 Fax: +41 22 786 52 31

## BRIEF HISTORY

The first Edition of this guide was written as the standards for 10 Mbit/s CSMA/CD Baseband LANs were emerging from IEEE Project 802. As these standards were progressed to IS status by ISO/IEC JTC1, some changes were incorporated.

Installation practice evolved and some proprietary equipment became commonplace. One ECMA member company, with the consent of ECMA, used TR/26 1st Edition as a basis for an in-house planning and installation guide. This was subsequently offered to ECMA as a basis for a 2nd Edition of TR/26. The published version of TR/26 2nd Edition is the result of review and editing by ECMA TC32-TG10 and the valuable assistance of individual members of ISO/IEC JTC1 SC25.

This Second Edition of Technical Report TR/26 has been approved by the General Assembly of 28th June 1990.

## Table of Contents

	Page
1 GENERAL	1
1.1 Introduction	1
1.2 Scope	1
1.3 References	2
1.4 Definitions and Acronyms	2
1.4.1 AUI Cable	2
1.4.2 Coaxial Cable	2
1.4.3 Coaxial Connector	2
1.4.4 Cable Section	2
1.4.5 Cable Segment	2
1.4.6 DTE Data Terminal Equipment	2
1.4.7 LAN - Local Area Network	2
1.4.8 Link Segment	2
1.4.9 Media Access Unit (MAU)	2
1.4.10 Network Components	2
1.4.11 Repeater	3
1.4.12 Terminators	3
1.4.13 Trunk Cable	3
2. SYSTEM OVERVIEW	3
2.1 Component Descriptions	3
2.1.1 Trunk Cable	3
2.1.2 10BASE5 Trunk Cable	3
2.1.3 10BASE5 Cable Connectors	4
2.1.4 10BASE2 Trunk Cable	5
2.1.5 10BASE2 Cable Connectors	6
2.1.6 Tap Connectors	7
2.1.7 MAUs	8
2.1.8 Transceiver Multiplexer	10
2.1.9 AUI Cable	11
2.1.10 Attachment Unit Interface (AUI) Cables	12
2.1.11 Data Port Kits	13
2.1.12 Repeater Units	15
2.1.13 Terminators	16
2.1.14 Earthing Clip	16
2.2 Network Configuration	17
2.2.1 Design Rules For 10BASE5 Trunk Cable Installations	17
2.2.2 Design Rules For 10BASE2 Trunk Cable Installations	18
2.2.3 Design Rules Applicable To Both Trunk Cable Systems	18
2.2.4 Network Symbols	18
3. PLANNING AND DESIGN	20

3.1	Introduction	20
3.2.	Building Types	20
	3.2.1 Existing Building	20
	3.2.2 New Buildings	21
3.3	The Site Survey	21
	3.3.1 Type of Building	21
	3.3.2 Type of Occupancy	22
	3.3.3 Risers	22
	3.3.4 Cable Routes	22
	3.3.5 Suspended Ceilings	23
	3.3.6 Under Floor Trunking	23
	3.3.7 Under Computer Style Flooring	23
	3.3.8 Wall Trunking	23
	3.3.9 Hazardous Environments	24
	3.3.10 Electrical Noise	24
	3.3.11 Mains Voltage Supplies	24
	3.3.12 Lightning Protection	24
	3.3.13 Site Access and Safety	24
3.4	Plans	25
	3.4.1 Floor Plan	25
	3.4.2 Schematic Layout	25
	3.4.3 Identify DTE Locations	25
	3.4.4 Identify Cable Routes	26
	3.4.5 Identify Locations Of Baseband Components	26
	3.4.6 Calculate The Length Of Trunk Cable	26
	3.4.7 Total The Network Components	26
	3.4.8 Installation Engineer's Works Instructions	26
	3.4.9 Schematic Layout Examples	27
	3.4.10 Labelling of Equipment and Cables	27
	3.4.11 Drawing Office Procedures	27
4.	NETWORK SYSTEM INSTALLATION	27
	4.1 Introduction	27
	4.2 Standards and Specifications	28
	4.3 Trunk Cable Installation Instructions	28
	4.4 Connector Installation	29
	4.4.1 N Series	29
	4.4.2 BNC Series	30
	4.5 Terminator Installation	31
	4.6 Earthing Arrangements	31
	4.7 Tap Connector Installation Instructions	32
	4.7.1 MAU Tap for 10BASE5 Cable	32
	4.7.2 BNC Tap	32
	4.8 MAU Installation	32
	4.8.1 MAUs with Tap Connectors	32

4.8.2	MAUs with BNC Connectors	33
4.9	AUI Drop Cable Installation	33
4.10	Data Port Kits Installation	35
5.	INSTALLATION TEST	35
5.1	Introduction	35
5.2	The Need for Rigorous Testing	36
5.3	Installation Checks	36
5.3.1	Test 1 - Pre-Installation Checks on Trunk Cable Media	36
5.3.2	Test 2 - Post-Installation Checks on Trunk Cable Media	37
5.3.3	Test 3 - Installation Checks on 10BASE5 Piercing Taps	37
5.3.4	Test 4 - Installation Checks on MAU, BNC with connectors	38
5.3.5	Test 5 - Installation Checks on 'T'-Piece Connectors	38
5.4	Acceptance Checks/Tests	39
5.4.1	Trunk Cable	39
5.4.2	MAUs and AUI Cables	39
5.4.3	Repeaters	40
6.	RECONFIGURATION & EXPANSION OF A BASEBAND CABLE NETWORK	40
6.1	Introduction	40
6.2	Baseband Cable Network Expansion	40
6.2.1	Extending the End of a Segment	41
6.2.2	Add A New Segment	42
6.2.3	Insert A Section Of Trunk Cable	43
6.3	Relocation Of An Existing MAU	44
	APPENDIX A - GLOSSARY OF TERMS	45
	APPENDIX B - DIAGRAMS, PLANS AND LABELLING DETAILS	51
	APPENDIX C - INSTALLED CABLE ACCEPTANCE TESTS AND EQUIPMENT	59
	APPENDIX D - COMPONENT CHECK LIST	63

## 1 GENERAL

### 1.1 Introduction

This guide is intended to assist in the planning, design, installation and system testing of 10 Mbit/s coaxial based CSMA/CD Baseband Local Area Networks (LANs), as specified in ISO 8802-3.

Being a bus topology, the main component of a Baseband LAN is the transmission medium. Two types of Trunk Cable will be encountered, one for use with 10BASE5 installations and the other for 10BASE2 networks. This guide explains the rules governing their use.

In addition to the passive Trunk Cable the Network System consists of various elements such as connectors, terminators, AUI cables, MAUs and repeater units. These items, once installed and connected together, constitute the transmission medium that supports the LAN.

Simplicity of installation and flexibility of layout are important characteristics of the approach in providing a high-performance, high-integrity Local Area Network. Equally important is the ease with which a system may be enlarged to cope with expanding needs. A small Network system concentrated on one floor, supporting a small number of users, may be progressively enlarged to a final system servicing an entire multi-storey building, or a community of multiple buildings.

Such a system may also be connected to remote Data Terminal Equipment (DTE) of other systems via communication gateways and external transmission lines, including optical fibre. Clearly, the planning and installation activity will vary greatly depending on the size and complexity of the system.

Successful network operation is the end product of good and thorough planning. The planner will evaluate the restrictions imposed by National Regulatory bodies, the building lease, type of structure, facilities requirements, health and safety regulations, prevailing electrical installation practices, equipment location and quantity, cable performance specifications, floor plan and budget.

### 1.2 Scope

This guide is intended to assist in the planning, design, installation and system testing of 10 Mbit/s coaxial based CSMA/CD Baseband LANs as specified in ISO 8802-3. It covers the following key activities:

- plan and design the cable route according to the distribution of the stations to be connected and the physical constraints of the building;
- install the cable network hardware;
- test the cable network hardware.

The preparation of this 2nd Edition was based on ECMA TR/26 1st Edition and ISO 8802-3. Also recommendations are given for some additional equipment that is currently not covered by ISO 8802-3, but may well be used in combination with it. This additional material may contain some implementation-specific information. The recommendations of this report may usefully be applied beyond the scope of ISO 8802-3.

Bearing in mind that most networks will grow and evolve over a period of time, this should be taken into consideration at the initial design stage.

This guide does not include the installation of the range of baseband interface equipment. Neither is it intended to cover CSMA/CD Broadband Lans or Fibre Optic installations, other than repeater links.

Safety requirements for LANs are covered in Standard ECMA-97.

### **1.3 References**

- ECMA-97      Local Area Networks - Safety Requirements
- ISO 8802-3    Local Area Networks - Part 3: CSMA/CD Access Method and Physical Layer Specifications
- IEC 169-16    N-type connector
- IEC 169-8     BNC connector

### **1.4 Definitions and Acronyms**

For the Purpose of this guide the following definitions and acronyms apply. A complete Glossary of Terms can be found in Appendix A, at the rear of this guide.

#### **1.4.1 AUI Cable**

Attachment Unit Interface Cable, AU Interface, AUI. (DTE-MAU connection cable). The Physical interface between the DTEs Physical Signaling (PLS) sublayer and the MAUs Physical Medium Attachment (PMA) sublayer the AUI carries encoded control and data signals.

#### **1.4.2 Coaxial Cable**

A two-conductor (centre conductor and shield), concentric, constant-impedance transmission line used as the trunk medium in 10BASE2 and 10BASE5 systems.

#### **1.4.3 Coaxial Connector**

The type of connectors attached to each end of a coaxial cable section.

#### **1.4.4 Cable Section**

A continuous length of coaxial cable, fitted with connectors at each end.

#### **1.4.5 Cable Segment**

A length of coaxial cable made up from one or more cable sections and connectors, electrically terminated at each end with its characteristic impedance (50 ohms).

#### **1.4.6 DTE Data Terminal Equipment**

A network addressable node, the source and destination for communications on the network.

#### **1.4.7 LAN - Local Area Network**

A data network optimised for a moderate size geographic area such as a single office building, a warehouse, or a campus. Generally comprises a single communications channel of moderate to high data rate, low delay and low error rate, offering multi-user access.

#### **1.4.8 Link Segment**

A point-to-point cable segment terminated in a repeater at each end. It is not permitted to connect stations to a link segment.

#### **1.4.9 Media Access Unit (MAU)**

The portion of the physical layer that interconnects the trunk cable to the AUI cable and contains the electronics which send, receive and manage the encoded signals impressed on, and recovered from, the trunk cable.

#### **1.4.10 Network Components**

The hardware elements that make up the transmission system of the network (i.e. cables, MAUs, repeaters, connectors).



#### **1.4.11 Repeater**

An electronic device used to extend the length and topology of the network beyond that imposed by a single segment, up to that allowed by the maximum round-trip propagation delay. A Repeater performs the basic functions of restoring the signal amplitude, waveform and timing. Additionally it can automatically isolate faulty segments and reconnect after the fault has been cleared.

#### **1.4.12 Terminators**

A special connector fitted to the ends of cable segments. These connectors contain a resistor between their inner and outer conductors. The value of the resistor matches the characteristic impedance of the cable used, (50 ohms).

#### **1.4.13 Trunk Cable**

The trunk coaxial cable chosen for the system.

## **2. SYSTEM OVERVIEW**

Before planning and designing the physical layout of a Network System, it is necessary to become familiar with the components and configuration specifications. This section provides:

- details of the network components;
- component configuration guidelines and specifications to ensure a properly designed Network System.

### **2.1 Component Descriptions**

The components described in this section do not comprise all that may be encountered and are included for information only. ISO 8802-3 should be consulted for detailed specifications, in particular in cases where the component is described in that standard.

#### **2.1.1 Trunk Cable**

The Trunk Cable is a constant impedance transmission line of circular cross section. It is used to inter-connect MAUs. As previously stated, there are two types that will be used. They are referred to as 10BASE5 and 10BASE2 cables.

#### **2.1.2 10BASE5 Trunk Cable**

This 50-ohm Trunk Cable normally has a bright coloured jacket marked at 2,5 m intervals with black bands. These marks are important as it is at these points, and only these points, that all placement of MAUs should be made, to a tolerance of  $\pm 0,05$  m. It is also recommended that terminations be placed on these marks.

Care must be taken to ensure that the cable materials are compatible with the installation environment. Normal PVC materials should satisfy the majority of situations, however local safety codes may in some cases stipulate that these cables are enclosed in trunking. Low smoke and fume grades of PVC or Teflon covered cables may be required so check this out during the site visit.

10BASE5 PVC Trunk cables often have a yellow outer jacket with a nominal outside diameter of 10,3 mm. 10BASE5 Teflon Trunk coated cables are often orange in colour and have a slightly smaller outside diameter, nominally 9,5 mm.

The maximum length of a trunk cable segment using this medium is restricted to 500 m (1640 ft).

The minimum bending radius of 10BASE5 trunk cable is 254 mm (10").

MAUs may attach to the cable via either a piercing non-destructive tap (see 2.1.6 for details), or by a tap equipped with type N connectors (see 2.1.3 for details).

*NOTE 1*

*Insertion of Type N taps will halt all communications on the cable segment being worked on. Normally, inserting a piercing style tap into a 10BASE5 Trunk Cable will have no adverse effect on network transmissions. However, it is essential that when work of this nature is to be carried out on 'live' systems, it should only be commenced AFTER the full consent of the customer's Network Management has been received.*

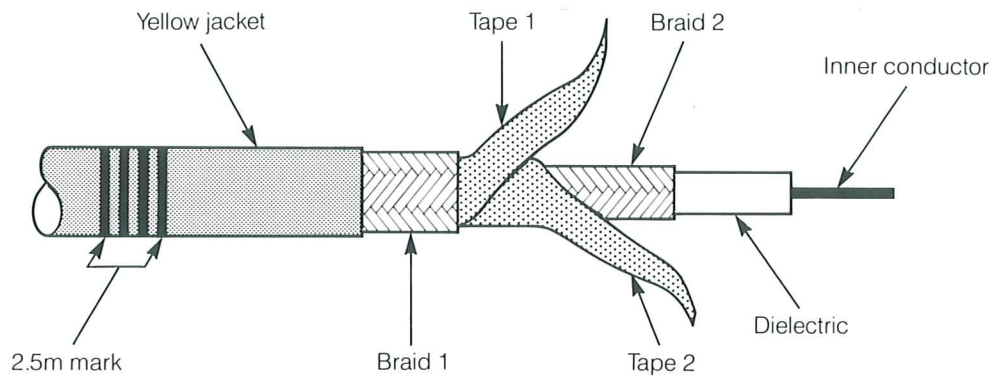

**Figure 1 - 10BASE5 Trunk Cable**

**2.1.3 10BASE5 Cable Connectors**

Coaxial cable connectors are used to join Trunk Cable sections and attach Terminators.

All connectors are 'N' series, 50-ohm constant impedance. As frequencies in the transmitted data are band-limited to approximately 50 MHz, military versions of the connectors are unnecessary, but are acceptable.

**Male Plugs** are fitted at the ends of all Trunk Cables, preferably within  $\pm 0,05$  m of a 2,5 m mark.

**Female-to-Female Barrel Connectors** are used to join Trunk Cable sections.

**Female Terminators** are used for terminating both ends of a Trunk Cable segment.

(See 4.4.1 for installation details)

## 10BASE5 TRUNK CABLE N CONNECTORS

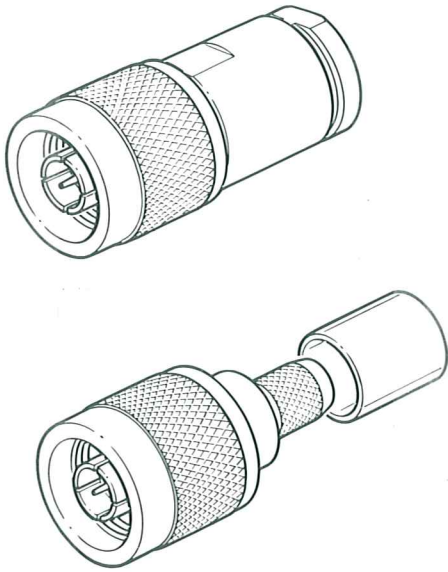

Figure 2 - Male Plug

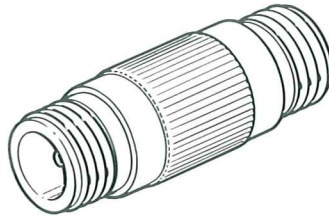

Figure 3 - Female-Female  
Barrel Connector

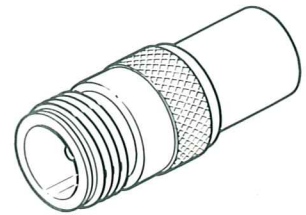

Figure 4 - Female Terminator

### 2.1.4 10BASE2 Trunk Cable

This 50-ohm Trunk Cable normally has a PVC jacket without 2,5 m marks. MAUs may be placed as little as 0,5 m apart, but no less.

The maximum length of a trunk cable segment using this medium is restricted to 185 m. Attenuation at 10 MHz is required to be no more than 8,5 dB for a length of 185 m.

The minimum bending radius of 10BASE2 trunk cable is 50 mm (2").

MAUs are coupled into the cable via BNC 'T' connectors, thus it is necessary in this case to cut the cable and fit connectors to the severed ends. It is recommended that, at the time of cable installation, BNC Female connectors (Barrels) are placed at possible DTE locations.

10BASE2 is normally intended to serve local clusters of DTEs. Should it be necessary to carry out formal installations of 10BASE2 cable, the following must be observed.

#### NOTE 2

*Cutting a 10BASE2 Trunk Cable will bring all transmissions on that segment to a halt, so it is essential that this type of work, when being carried out on 'live' systems, is only executed with the full knowledge and consent of the customer's Network Manager.*

Care must be taken to ensure that the cable materials are compatible with the installation environment. Normal PVC materials should satisfy the majority of situations, however local safety codes may in some cases prohibit this. Low smoke and fume grades of PVC or Teflon may be required so check on this during the site visit.

10BASE2 Trunk PVC cables generally have an outside diameter of 4,9 mm  $\pm$  0,3 mm.

10BASE5 Trunk Teflon coated cables have, generally, an outside diameter of 4,8 mm  $\pm$  0,3 mm.

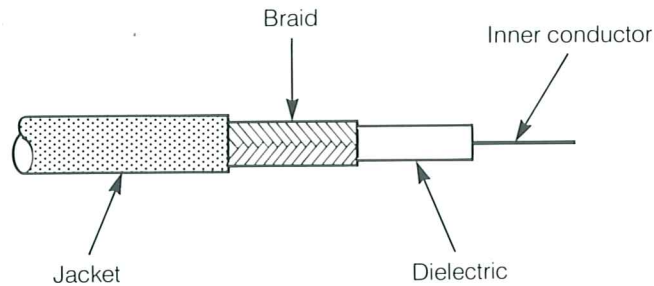

**Figure 5 - 10BASE2 Trunk Cable**

**2.1.5 10BASE2 Cable Connectors**

Coaxial cable connectors in the 50-ohm BNC range are used to join 10BASE2 Trunk Cable sections, attach Terminators and connect to MAU taps.

**Male Plugs** are fitted at the ends of all Trunk Cables.

**Female-Female Barrel Connectors** are used to replace unused 'T'-Pieces or to join Trunk Cable sections and terminators.

**Female-Male-Female 'T'-Piece Connectors** are used to join Trunk Cable sections to some styles of MAUs.

**Male Terminators** are used for terminating both ends of a Trunk Cable segment.

(See 4.4.2 for installation instructions)

Care must be taken to ensure that the connector shell (connected to the trunk cable screen) is insulated from any building metal, or other unintended conductor, using a suitable connector shroud.

The insulation should be used to cover the connector during the installation phase, and must be replaced after any subsequent work which entails its removal.

## 10BASE2 TRUNK CABLE BNC CONNECTORS

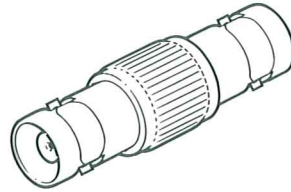

Figure 6 - BNC Female

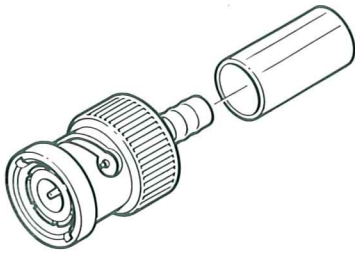

Figure 7 - BNC Male

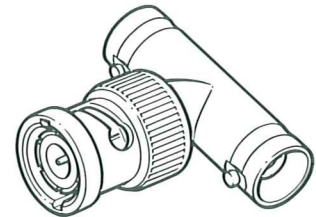

Figure 8 - BNC 'T'-Piece

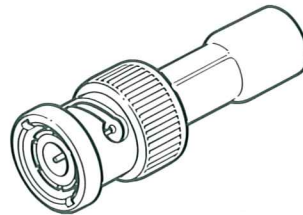

Figure 9 - BNC TERMINATOR

### 2.1.6 Tap Connectors

MAU's may connect to 10BASE5 media via a piercing tap kit, (Figure 10), or a tap equipped with type N connectors. MAUs will connect to 10BASE2 cables via either BNC 'T'-pieces or a BNC Tap, (Figure 11).

Tap assemblies may vary between manufacturers, but guidance is given in ISO 8802-3 that the taps consist of a clamp assembly, a tap body, ground probes, a probe assembly.

Fitted only at the 2,5 m marks on the sheath of 10BASE5 trunk cables, the two halves of the tap should be clamped together, sandwiching but not crushing the cable between them. The clamping action forces the ground probes, fitted in one half of the clamp, to pierce the cable's outer jacket and make durable electrical connections with the outer conducting braids and tapes. A probe is then fitted to the clamp such as to make permanent contact with the central conductor, but isolated from the outer braiding. This may require some material to be removed by manually drilling the cable.

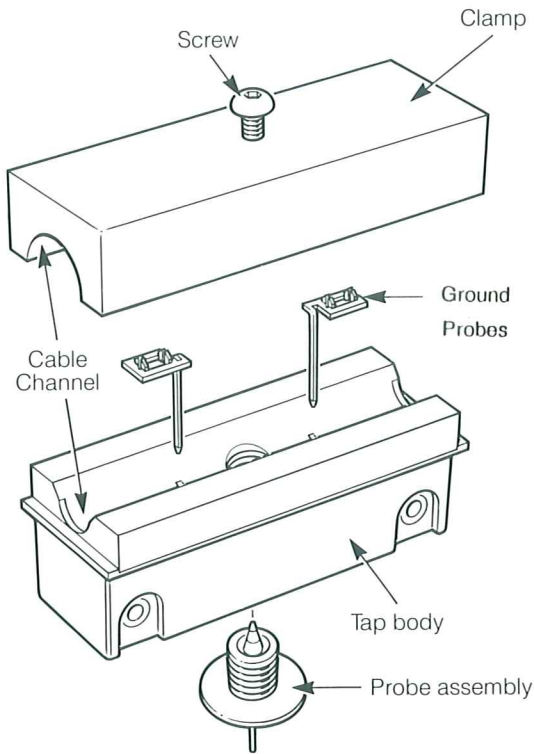

Figure 10 - 10BASE5 Piercing Tap

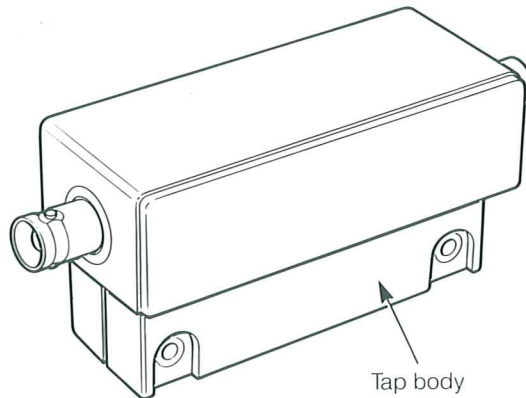

Figure 11 - BNC Tap (10BASE2 Cable)

### 2.1.7 MAUs

Media Access Units (or Transceivers) are the devices that access the Trunk Cable by direct connection. They act, on behalf of the station(s) to which they are attached, as a transmitter and receiver of network information. The method of connection to the trunk media will vary for the type of MAU used and the type of cable in use (see below).

One interface, therefore, is to the trunk media, the other has been agreed by the International Standards Organisation to be a 15 pin D-type plug for connection of the AUI cable. It should be noted that such a connection is optional as some MAUs form integral parts of some DTE devices and therefore require no AUI cable.

The number of MAUs supported on one cable segment is dependent on the type of trunk cable used, and is as follows:

- up to 100 MAUs on 10BASE5 cable segments, spaced at multiples of 2,5 m intervals. The Trunk Cable is physically marked every 2,5 m to assist with the MAU placement;
- up to 30 MAUs on 10BASE2 segments. Minimum spacing of 0,5 m between MAUs.

The following examples of MAUs may be encountered in Baseband networks:

i) Trunk Cable MAU

These units have a built in AUI port and an opening for a cable tap. Trunk cable MAUs may have the SQE test function enabled or disabled depending on application. For example, it is necessary to disable the SQE test for MAUs connected to repeaters.

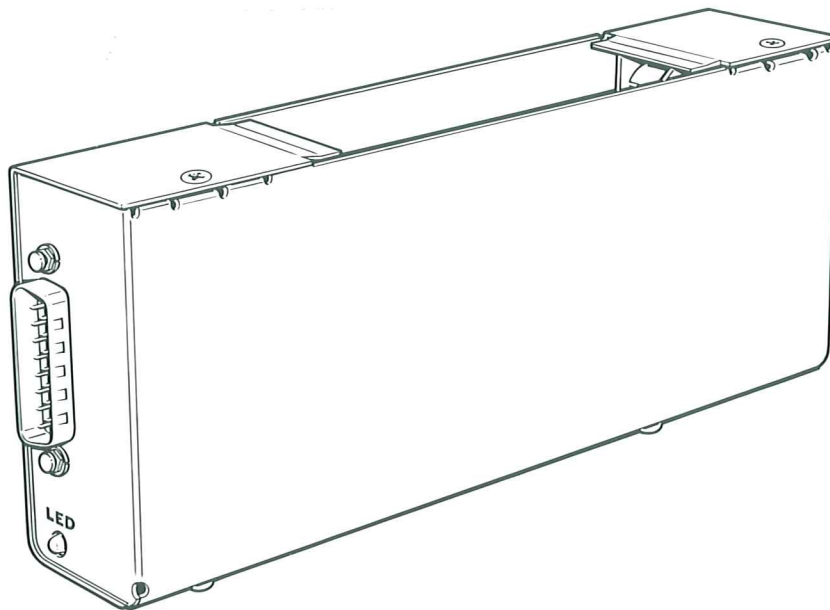

Figure 12 - Typical MAU (not to scale)

ii) On-Board BNC MAU

Some DTE devices incorporate a MAU and offer a 50 ohm bulkhead connector. Connection to a 10BASE2 cable installation is then possible via a BNC "T"-piece inserted in a 10BASE2 trunk cable. **Coaxial drop leads between "T"-pieces and PC DTEs are not allowed.**

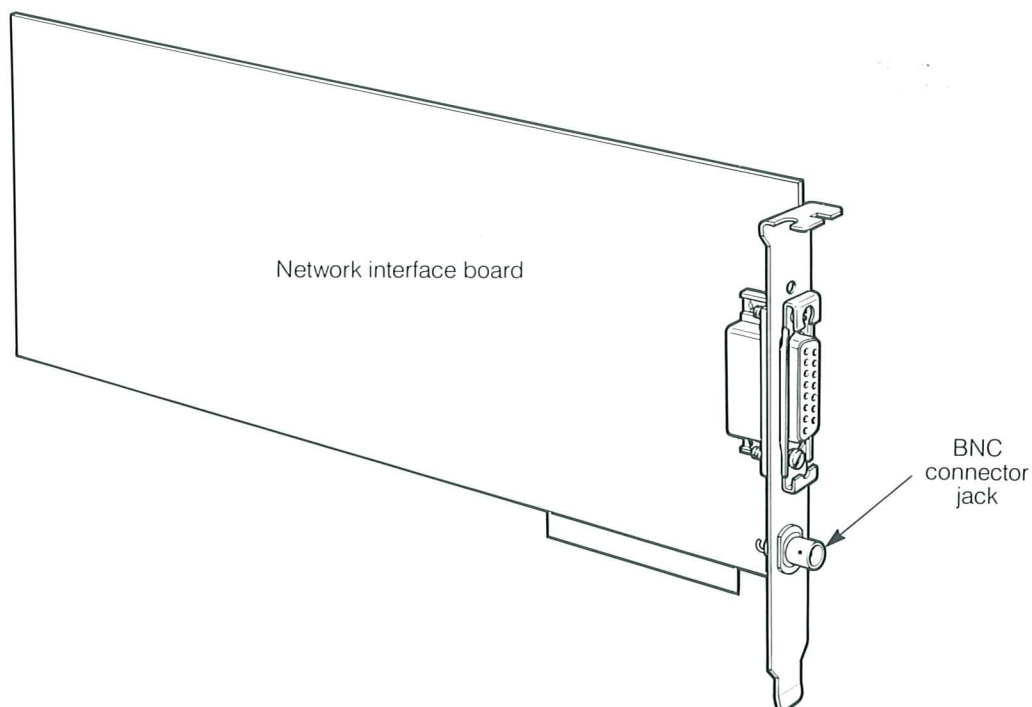

Figure 13 - On-Board BNC MAU

### 2.1.8 Transceiver Multiplexer

Transceiver Multiplexers are not covered by any published standard at the time of writing. Consequently different implementations exist, varying in e.g. the number of DTEs supported, network connection options.

Although Transceiver Multiplexers are beyond the scope of ISO 8802-3, they have been found useful devices in some applications, therefore they are discussed in this section.

A Transceiver Multiplexer, or 'fan-out' unit, a number of ports simulating MAU functions. Some Multiplexers allow for the connection to the network cable via a MAU and associated AUI cable, just as if the Multiplexer were a DTE. DTEs can then connect to the network via the MAU ports on the Multiplexer unit.

If no network connection is made, or if the cable network were to fail, some implementations of a Transceiver Multiplexer may self-configure automatically into a stand-alone mode.

If a greater concentration of MAU ports is required it is possible to cascade Multiplexers, (eg one feeding another eight) giving up to sixty-four ports for one network connection. There are two drawbacks with this method of working, one is that the network MAU and its cable are single points of failure for a large population of users; secondly each multiplexer increases signal jitter (pulse distortion) and impact on the end-to-end delay for AUI cables. The total jitter and end-to-end delay must be constrained within the overall network allowances (refer ISO 8802-3). This imposes **distance penalties** on the cascaded AUI cables (see Figure 14).



It is not possible to increase the range of Trunk Cable to DTE beyond the 50 m (164 ft) maximum using Transceiver Multiplexers (see 2.1.10).

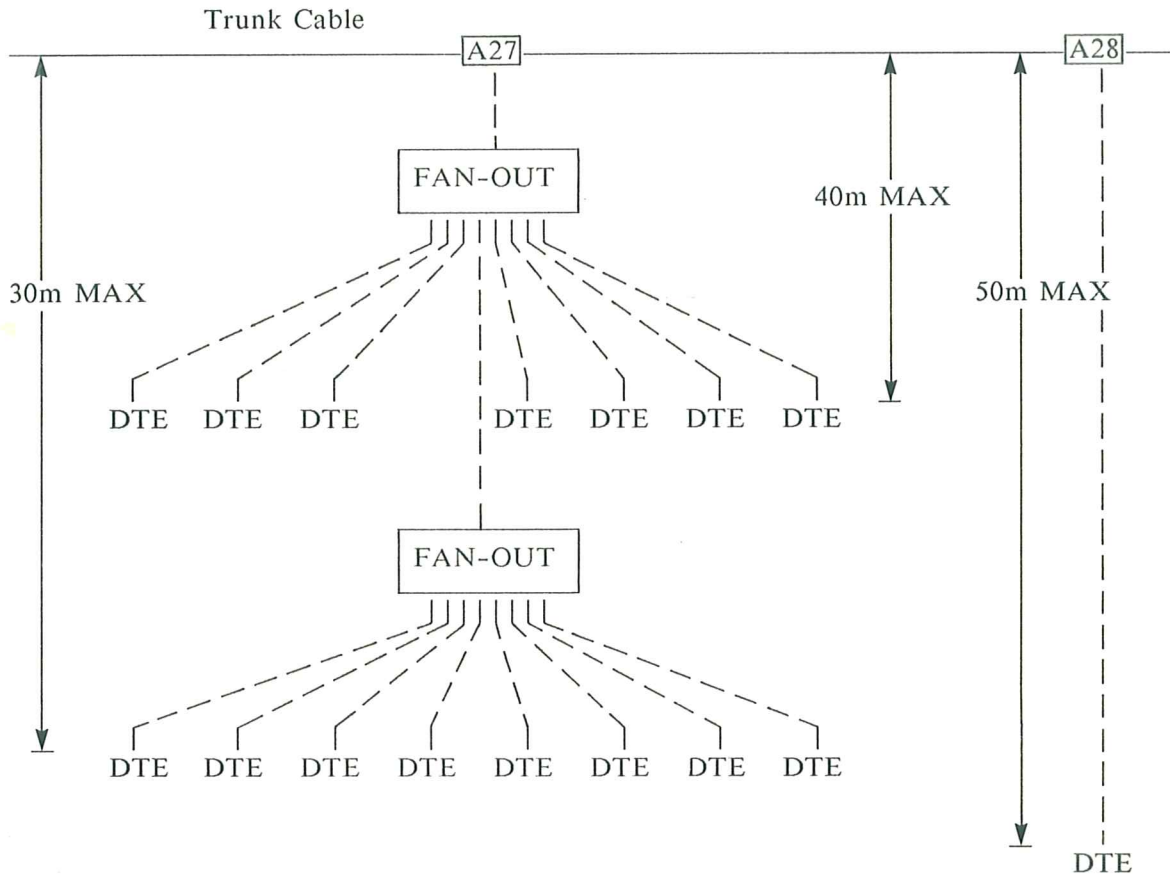

In this example a 10 m penalty has been assumed.

Figure 14 - Example of the Use of Transceiver Multiplexers

### 2.1.9 AUI Cable

The AUI cable, when terminated with a 15 pin D-type plug and socket, connects a MAU to a DTE, thus allowing that DTE access to the network. This composite cable consists of 4 individually shielded twisted pairs, each conductively coupled to Earth Drain Wire(s). These screened pairs are then wrapped with an insulating film which isolates them from a tape and braid outer screen. An insulating jacket of some 10 mm outside diameter (depending on manufacturer) then encompasses and protects all the conductors. An example of the makeup of this cable can be found below in Figure 15.

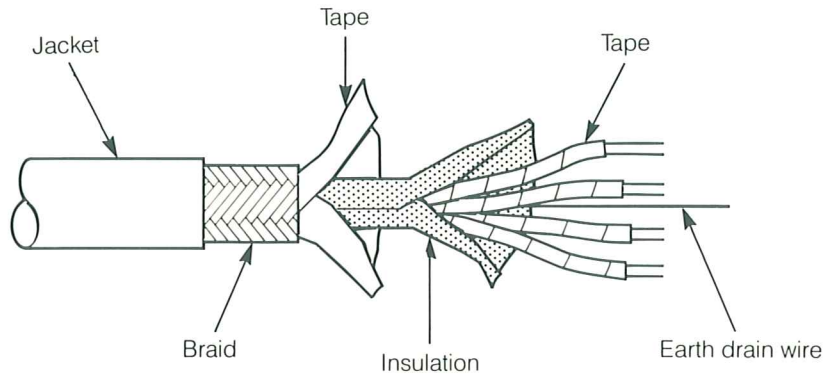

**Figure 15 - Example of an ISO 8802-3 AUI Cable (with Central Earth Drain Wire)**

AUI cables of identical makeup, but of reduced diameter are also available, however these impose length restrictions. These restrictions vary from manufacturer to manufacturer. Only standard AUI cable is covered by ISO 8802-3. However this is more user unfriendly in office locations than some thinner types on the market. Most manufacturers publish a "deviated factor" to cover their cable. Maximum lengths allowed vary between 8 and 30 meters dependant on the manufacturer.

Pin-outs and earthing arrangements for AUI cables can be found in 4.9.

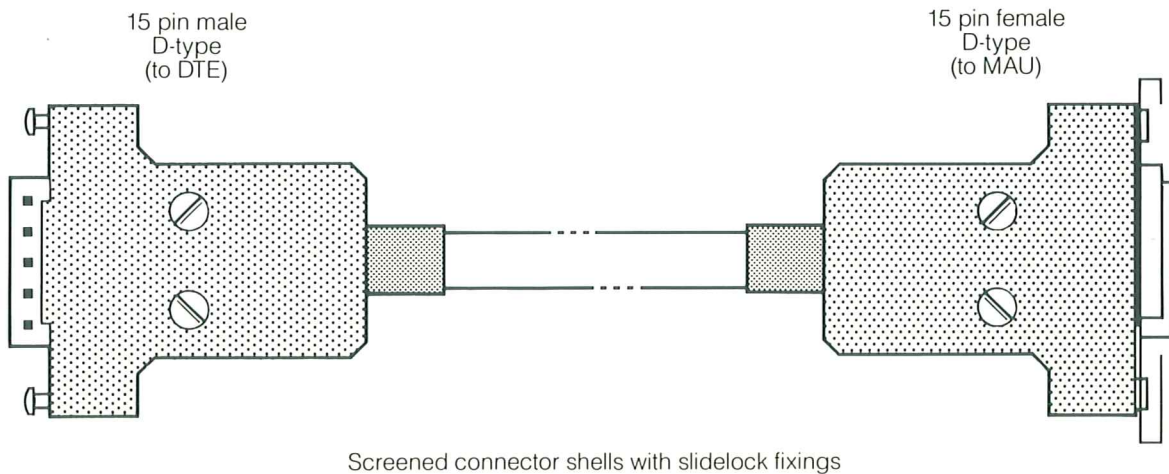

**Figure 16 - An AUI Cable with D-Type Connectors**

**2.1.10 Attachment Unit Interface (AUI) Cables**

The maximum permissible length of standard AUI cable attached to any MAU is 50 m (164 ft).

To perform the role of an AUI Cable, the cables described in 2.1.9 should be terminated with 15 pin D-type connectors at either end (1 male, 1 female). The D-type connector shells must be of the screened type and fitted with slidelock strain relief mechanisms (female connector slide latches, male connector lock posts, see Figure 16) in accordance with ISO 8802-3

In normal usage a single AUI cable should be used to connect a station to a MAU on the Trunk Cable. Theoretically multiple lengths of AUI cable could be chained like extension cords, but each additional connector introduces performance and reliability degradation.

**Chaining of more than two lengths is not recommended.**

If chaining is deemed necessary to meet an unusual layout requirement, or if a mix of thick and thin AUI cables are to be used for Data Port provision, then two lengths may be chained, provided the lengths used conform to the following rule:

$$\frac{\text{Length of cable type A}}{\text{Distance capability of type A}} + \frac{\text{Length of cable type B}}{\text{Distance capability of type B}} < 1$$

Planners please note: The manufacturers recommendations regarding distance capabilities must be consulted. Some equal 8 m, or 15 m, or 20 m. There are bound to be others.

Length of 'A' Cable AUI 1A (metres)	Maximum Length 'B' Thin AUI Cable assuming 8 m max. (metres)
for 50 m	add 0 m
for 43 m	add 1 m
for 37 m	add 2 m
for 31 m	add 3 m
for 25 m	add 4 m
for 18 m	add 5 m
for 12 m	add 6 m
for 6 m	add 7 m
for 0 m	add 8 m

**Table 1 - Example of Permissible Mixes of Thick and Thin AUI Cables**

AUI cables do not require termination when not in use, but dust covers are available if required.

It is very important that 'as built' schematic diagrams and Data Port labels record the length and type of installed AUI cable.

An example of this type of record, using the Network Symbols and Data Port Labels can be seen in Appendix B.

**2.1.11 Data Port Kits**

Although these devices are beyond the scope of the referenced standards, they provide means of pre-cabling a building, or part of building, such that connection points are provided at convenient locations. This can be regarded as future proofing the customers installation, affording him flexibility of movement without the need for expensive recabling work. If using this method of installation, extra care should be taken to ensure that no more than the

maximum number of permissible MAUs are/can be installed in one single segment (see 2.2).

A data port kit can be connected via an AUI cable to either a MAU installed on the Trunk Cable or to a Transceiver Multiplexer, the AUI cable being concealed in, on or behind a wall. The DTE can then connect to the data port kit by means of a second AUI cable.

When planning this type of installation, care must be taken to ensure that the maximum length restriction of 50 m is adhered to (see also Table 1).

Although some different styles of Data Port Kits are available, the form and fit of such devices may not suit the customers requirements. If this is the case the following points should be observed in fabricating alternative kits:

- the Data Port Kit 15-pin 'D'-type connector should be male with lock posts;
- The AUI Cable connector should be housed in a totally effective radiation screen. This can be achieved if the body of the Data Port Kit is fabricated from steel, or the termination is enclosed in a screened connector shell. However, the AUI connector shall be isolated from the steel case to avoid false grounding (see also 4.10).

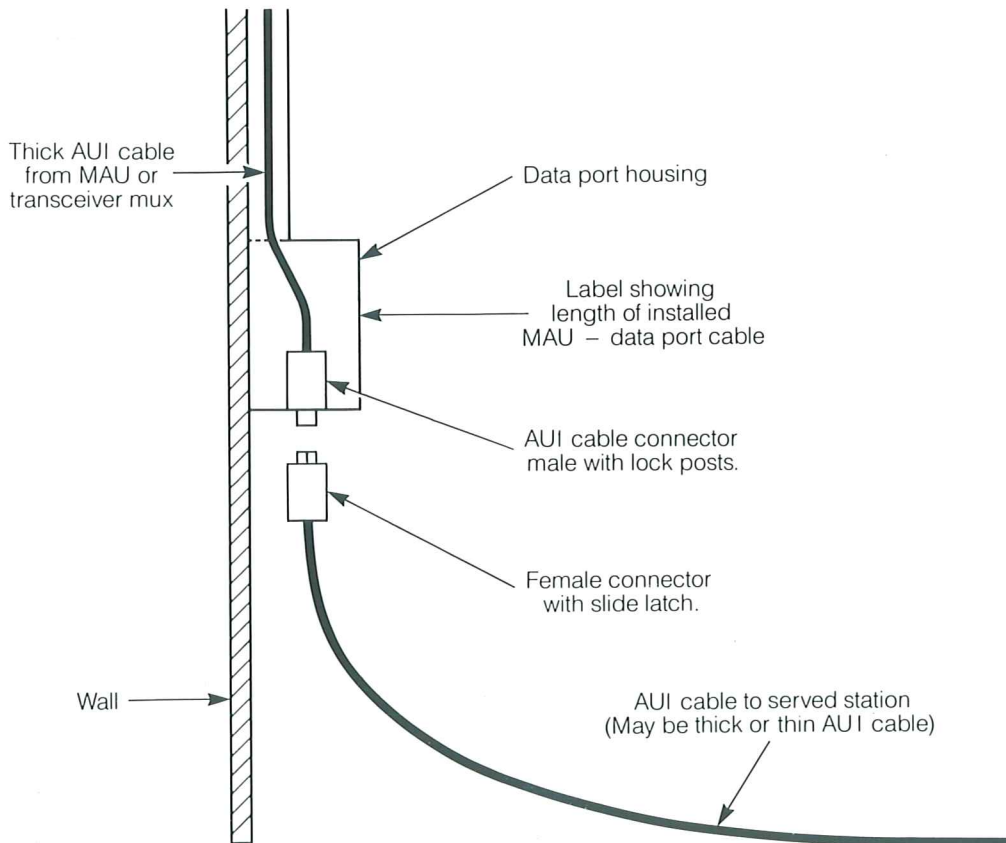

Figure 17 - Typical Data Port Installation

### 2.1.12 Repeater Units

Although there are restrictions on the maximum length of a cable segment dependent on the medium used, (see 2.1.2 and 2.1.4) a number of segments may be linked using Repeaters. The maximum transmission path permitted between any two stations is five segments, four repeater sets (including optional AUIs, two MAUs, and two AUIs). Of the five segments a maximum of three may be coaxial segments, the remainder are link segments.

Repeater Units must not be connected in parallel or else the network will lock up. Therefore, before installing, ensure that the two segments involved are not already connected.

Repeater Units can be used to create branches from a main Network Segment as required. Note that Repeater Units may require access to a mains power supply.

#### 2.1.12.1 Repeater Units connecting Coaxial Segments

Procedure to link two segments using Repeater Units:

- take two MAUs with SQE set to off;
- install the MAUs, one on each of the Trunk Cable segments to be linked;
- connect both MAUs to the Repeater's ports using standard AUI cable;
- connect and power on the repeater units.

No software configuration is normally required although some manufacturers now incorporate management functions with some of these products.

Strict rules govern the maximum number of coaxial Repeater sets that are permitted in any communicating path on the network (see 2.2.3(i)). The longest theoretical separation between any two workstations using Local Repeaters is therefore 3000 m. Note however, that repeaters can be attached via a MAU installed at any 2,5 m point on the trunk cable and need not necessarily be located at the segment ends, unless it is a Link Segment.

Link Segments have no DTEs connected to them, only MAUs at each end.

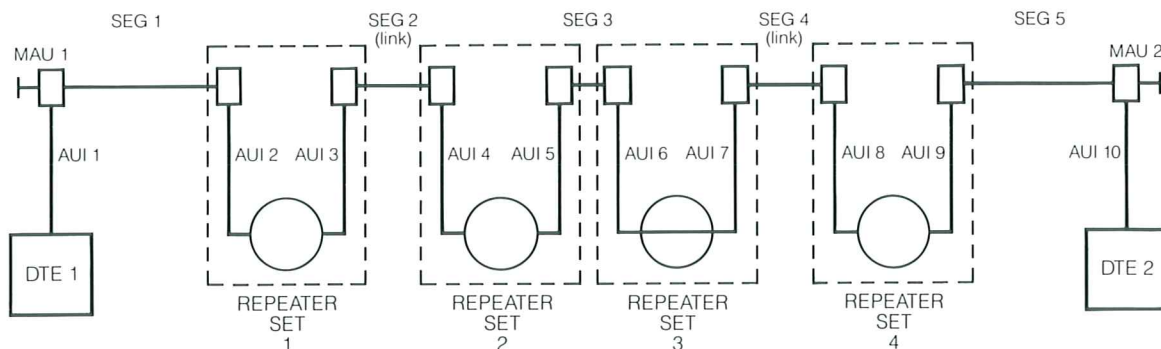

Figure 18 - 10BASE5 Trunk Cable Network Using Coaxial Cable Repeater Units

### 2.1.12.2 Optical Fibre Repeaters and Links

Optical Fibre Repeaters usually have an AUI port and a fibre port. Fibre optical cable forms a link segment. The properties of optical fibre cables make them useful when requiring:

- connecting buildings together externally (protection from lightning);
- passing through areas with a high level of radio frequency emissions;
- security in multi tenant buildings; etc.

Strict rules apply as to the maximum length of transmission media allowed between distant DTEs that are connected together using a mixture of fibre optical and coaxial cables. Figure 19 is a model example of such a length restriction, e.g. up to 1500 m coaxial, 1 km fibre (as for Fiber Optical Inter-Repeater links); 6 x 50 m AUI cable, totalling 2800 m.

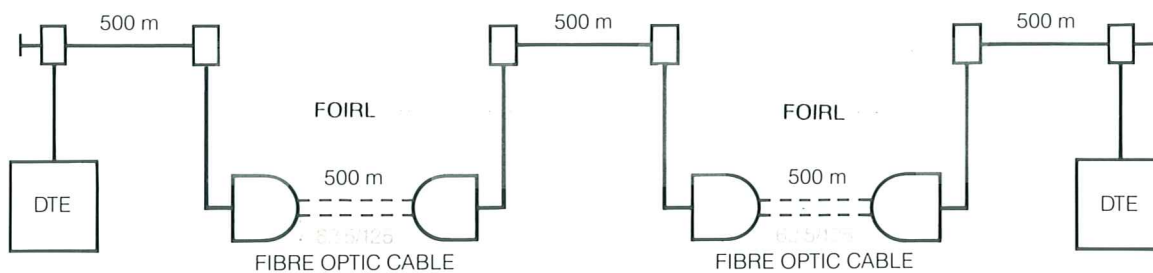

Figure 19 – 10BASE5 Trunk Cable Network Using Fibre Optic Repeater Units

### 2.1.13 Terminators

Terminators must be fitted at each end of a Trunk Cable segment. If they are not present, or are loose, the Network System will malfunction.

#### 10BASE5 System

The terminators in the 10BASE5 system are 50-ohm, 1-watt devices housed within female connectors. Provision may be made for earth attachment at the terminator (see 2.1.14). After they have been installed, ensure that the connector shell and the terminator are insulated.

#### 10BASE2 System

The 10BASE2 style terminators are 50-ohm, 0,5-watt devices with a male connector. The terminator and its associated connector should be insulated using a Connector Shroud.

### 2.1.14 Earthing Clip

The outer screen of each 10BASE5 trunk cable segment should be earthed once only.

An Earthing Clip provides a means of attachment to a barrel connector, or terminator, and should be cabled and connected to the nearest electrical earth distribution point (see also 4.6 Earthing Arrangements). Observe local codes when running earth wires.

Ensure that the connector shell and earth clip are insulated from any inadvertent earths.

*NOTE 3*

*10BASE2 cable segments are not required to be earthed, but it is strongly recommended that they are, and in the same manner as 10BASE5 cables, i.e. only once.*

## 2.2 Network Configuration

The planning rules governing the provision of ISO 8802-3 networks must be obeyed or else the network as built may not function after installation. Some rules depend upon the type of trunk medium to be used. The following paragraphs state these rules for networks without MAC bridges.

Appendix B shows some typical cable network configurations.

### 2.2.1 Design Rules For 10BASE5 Trunk Cable Installations

- i) Cable type = Standard ISO 8802-3 10BASE5 cable.

The following rules are given in order of preference.

Where possible, a coaxial cable segment should be made from one length with no breaks. This approach is usually feasible for shorter than maximum length networks and minimises unwanted reflections from cabling discontinuities.

If the coaxial cable must be cut into sections, as long as cable from the same cable batch and extruder run is used, it may be cut at any 2,5 m point and connectors added. One way of obtaining a coaxial cable length from a single extruder run is to purchase 500 m drums of coaxial cable and cut these into the required lengths. Maintenance lengths should also be from the same batch and obtained at the outset of the installation.

If a single-section segment is impractical, and cutting a known single segment is also impractical, the installation of 10BASE5 cable sections cut to the standard lengths of odd-integer multiple of 23,4 m is strongly recommended. These particular lengths minimize the successive in-step buildup (inphase addition) of reflections from adjacent sections. Recommended odd-integer lengths are : 23,4 m ; 70,2 m ; 117 m ( $\pm 0,5$  m).

- ii) Maximum segment length = 500 m.
- iii) MAUs must be placed on 2,5 m spacing marks ( $\pm 0,05$  m).
- iv) Maximum number of MAUs allowed on one cable segment = 100.
- v) Minimum bending radius = 254 mm (10 inches).
- vi) Piercing or type N style taps should be used.
- vii) 50-ohm 'N' type connectors and terminators are to be used.
- viii) Each cable segment should be earthed once, and once only. All exposed cable conductors must be insulated from inadvertent earth connection. (see 2.1.14).
- ix) A 10BASE5 segment may be connected (via a repeater) to a 10BASE2 segment. However, 10BASE2 segments must not be used to bridge 10BASE5 segments together.
- x) If only two link segments are used in the entire network and they are adjacent, the repeater set joining them is not required.

### 2.2.2 Design Rules For 10BASE2 Trunk Cable Installations

- i) Cable type = RG58 A/U or RG58 C/U.
- ii) Maximum segment length = 185 m (600 ft).
- iii) Minimum spacing between MAUs = 0,5 m (20").
- iv) Maximum number of MAUs allowed on one cable segment = 30.  
Maximum number of BNC T adaptors = 60 (only 30 equipped with MAU).
- v) Minimum bending radius = 50 mm (2 inches).
- vi) 50-ohm BNC connectors and terminators should be used. 'T' adaptors or BNC style taps should be used to connect MAUs.
- vii) 10BASE2 Trunk Cables must not be connected to more than one 10BASE5 segment, i.e. should be at the periphery of the network when in a mixed configuration.
- viii) Any unused BNC T-Piece male connectors must NOT be terminated but left inside a suitable protective boot.

### 2.2.3 Design Rules Applicable To Both Trunk Cable Systems

- i) A maximum of four repeater units are permitted in any communicating DTE-DTE path.
- ii) Maximum number of addressable Nodes on one network ID = 1024.
- iii) Maximum length of thick AUI cable = 50 m (164 ft).
- iv) Maximum length of thin AUI cable dependent on manufacturer, but less than 50 m in all cases (less than 8 m in some cases).
- v) Mixed thickness AUI cables should follow the rule in paragraph 2.1.10.
- vi) Electrical loops in or between trunk cables are not allowed.
- vii) MAUs must be connected directly to the trunk cables. Co-axial drop leads are not permitted on either cable system. Figure 20 refers.

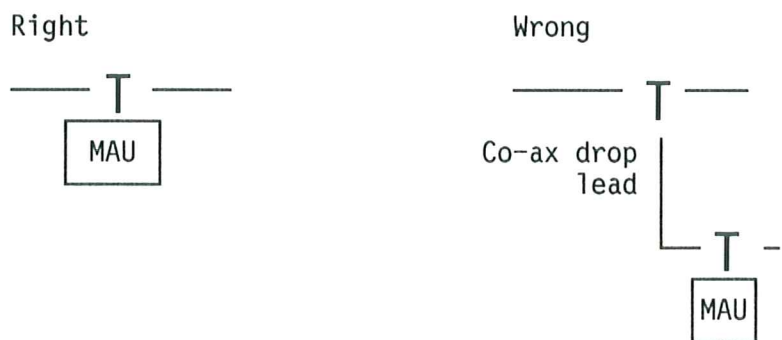

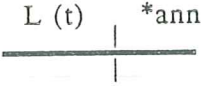



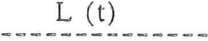





Figure 20 - Trunk Cable to MAU Connection

### 2.2.4 Network Symbols

These symbols are used to represent the network equipment on floor and schematic plans.



SYMBOL	EQUIPMENT
	Trunk Cable length 'L' type 't' (1 = 10BASE5, 2 = 10BASE2)
	Trunk Cable 'a' with Barrel Connector No. 'nn'
	Trunk Cable 'a' with 'T' Connector No. 'nn'
	Terminator (A = Cable Segment Name (A-ZZZ)) (N = Terminator Number (1 or 2))
	Terminator With Earth Strap
	MAU (A = Cable Segment Name, A-ZZZ) (NN = MAU Number, 00-99)
	AUI Cable (Drop Cable) length "L" t = type No. 1 or 2 (1 = thick, 2 = thin)
	Data Port 'DP' No. 'n' (n = 1 to ?) t = type No. 1 or 2 (1 = thick, 2 = thin) length 'L' from MAU
	Server
	DTE
	Repeater set connecting two coaxial segments



Link Cable length 'L', type 'f' (f, or absent = fibre  
c = coaxial cable)



Repeater Unit connecting fibre optic link cables.

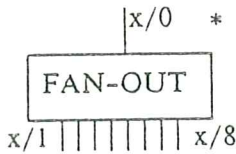

Eight port Transceiver Multiplexer

x = Allocated No.

/0 = Input (LAN access)

/1 to /8 = Outputs

\* = Geographical location of the device (in words)

### 3. PLANNING AND DESIGN

#### 3.1 Introduction

When planning and designing the physical layout of a Baseband Network the following factors should be considered:

- type of building structure;
- type of occupancy of the building;
- local building regulations;
- National Regulatory Body;
- the customer's requirements;
- the network configurations specifications;
- prevailing Health and Safety legislation.

This section addresses these areas and provides:

- general information on common building types, structures, and occupancy to enable the designer/planner to evaluate the building for installation feasibility;
- an outline set of rules for Site Surveys;
- a description of possible methods of equipment connection to enable the designer/planner to select an appropriate method and develop a plan based on this;
- a method of planning a network using customer floor plans, showing all System components and equipment on these plans;
- a procedure for designing a schematic drawing that shows Baseband network configurations.

#### 3.2. Building Types

##### 3.2.1 Existing Building

When a customer occupies only part of a building it may be to his advantage to cable the entire building.

The building owner and other occupants should be consulted regarding this.

Co-operation between parties may be of mutual benefit.

The building owner could regard this facility as an attractive asset for the future, enhancing its market value. For other occupants, it would provide networking capabilities at a much reduced installation cost.

There are some drawbacks to this however, for instance:

- some buildings may be protected from alteration;
- the customer may be required to hold a "carriers" license in order to operate the cable after installation;
- after installation, who will be the Network Administrator?
- who will organise additions and rearrangements?
- who pays for fault location?
- a single cable network in a multi-customer building reduces physical access security, opening the installation to unauthorised use, abuse or vandalism.

Answers to these, and other similar questions, should be sought before entering into any long-term support function.

### **3.2.2 New Buildings**

These provide a unique opportunity for installing a network physical infrastructure. The architect has the opportunity to provide concealed ducting to accommodate the Trunk Cable and the Drop Cables, and to provide data ports as required in every office.

### **3.3 The Site Survey**

No two Baseband installations will be identical, mainly because the buildings equipped with them will be different. To assess the quantities of cable and equipment needed, for all but the simplest network, a full survey of the proposed installation should be carried out.

The installation planner should survey the site thoroughly, with assistance from the authorities responsible for the premises (eg the customer's Site Service Manager). This authority should have intimate knowledge of the existing and proposed power sources, risers, conduits, trunking, cable trays, fire walls etc. Additionally the customer's Site Service Manager is required to provide floor plans of the areas to be cabled and be available for consultation regarding the installation.

During the survey the following factors should be taken into consideration:

- Type of Building;
- Type of Occupancy;
- Risers;
- Cable Routes;
- Suspended Ceilings - Environmental Air Space;
- Cabling Under Floors;
- Maintenance Access;
- Hazardous Environments;
- Mains Supplies;
- Electrical Noise;
- Lightning Protection;
- Site Access and Safety.

#### **3.3.1 Type of Building**

This will be the largest factor affecting the cost of the installation of cable plant, as different buildings will not take the same time to cable.

Modern multi-storey buildings are usually designed with communications in mind. They often have large risers between floors with access to either three compartment trunking set into the floor, or to the void under the building's extensive false floors. Most modern buildings have T bar suspended ceilings that offer possible routing for both trunk and AUI cables.

However, the older style buildings pose a communication planner quite a few problems. For example:

- the small risers, if they exist at all, are often choked with cable plant;
- floors may be solid, containing a few one inch steel conduits used for distributing the buildings telephone network, making them unusable for LANs;
- all previous cable installations may have been secured directly to the walls, there being no trunking or cable trays;
- concealed spline ceilings can give access problems;
- many old buildings still contain large volumes of asbestos.

These types of buildings may require the customer to make a few structural changes to incorporate the network.

### **3.3.2 Type of Occupancy**

This may have an effect on the installation of the cable plant. Outright ownership of the premises will present the fewest restrictions.

A lease may impose a number of restrictions on the customer. Leases may permit only the building owner's personnel to install the cable or require the tenant to submit plans of the intended installation for approval before any work can commence.

### **3.3.3 Risers**

If equipment is to be located on two or more floors, special attention should be given to the method of floor penetration.

If possible use existing risers to pass Trunk Cable between floors. Alternatively, concrete core drilling and the provision of trunking may have to be considered. REMEMBER if fire break material has to be removed to enable cable installation, it must be subsequently replaced. The Site Manager, or local contractor, may provide advice on these matters.

Traditionally network cables are not installed in lift shafts due to their inaccessibility.

If ventilation shafts are a chosen riser route, a number of precautions should be contractually agreed before work commences, namely:

- fireproof trunking MUST be provided by the customer to enclose the cables;
- suitable flooring must be provided in the shaft by customer before installation begins;
- that adequate illumination is provided in the shaft by the customer;
- that operatives within the shaft have a breathable atmosphere.

The cable should be supported with tie wraps every 3-4 m when installed in vertical risers (every 2-3 m in horizontal sections) to prevent stress on both cable and connectors. MAUs located within risers should also be supported. Thought should be given to the siting of the MAUs as they may become 'buried' by other cables subsequently installed.

### **3.3.4 Cable Routes**

Baseband cables must be installed to comply with local codes, aesthetic values, security, cost criteria, and the physical limits of the equipment to be attached.

Before drawing up any plans, the network planner should make a detailed site inspection, to determine the optimum route for the Trunk Cable and the placement of the MAUs, Repeaters and other associated devices, and ensure that mains power is available where required.

It is important that the most accessible route is chosen to allow the system to be easily tested, extended, re-routed or have damaged sections swiftly replaced.

All cables should not be installed in an area where they could be exposed to mechanical damage. This is an obvious precaution but, nevertheless, needs to be highlighted as prolonged down-time on data networks cannot be tolerated.

Some networks will not necessarily be confined to an office environment and should be protected accordingly.

A short route will reduce the installation cost and the chance of physical damage to equipment. Remember though, the route has to be long enough to accommodate all the required number of MAUs.

Where fire wall penetration is required, ensure that the local fire regulations are obeyed, and the position of the penetration should be noted on the floor plan.

### **3.3.5 Suspended Ceilings**

To cause the minimum of disruption within the building it is advisable to route the Trunk Cable in the suspended ceiling in corridors. Where this is not possible other routes should be selected as required. The Trunk Cable should be attached to the ceiling hangers every 2-3m, for support using tie wraps. Support MAUs in the same way, NEVER LEAVE MAUs LAYING ON CEILING TILES, they could cause an accident.

Many structures use the suspended ceiling space for air conditioning return flows. It is advised that PVC cable should be enclosed in a fireproof trunking. In some installations PTFE covered cables may well be acceptable to Fire Officers without the need of trunking so have the Site Services Manager check.

### **3.3.6 Under Floor Trunking**

Where use can be made of built-in conduit or floor trunking, special consideration should be given to ensure that cable will not bend less than its minimum bend radius, and will not be crushed or crimped during installation.

Baseband network cables can occupy the same compartment as other low voltage cables such as data and voice.

It is most unlikely that sufficient room will be found in existing floor traps to house MAUs as they are bulky, especially when the AUI cable is attached.

### **3.3.7 Under Computer Style Flooring**

Where raised floor exist the cables can be laid under the floor. Again consider if the cable will be crushed, crimped, or bent below its minimum bend radius. If MAUs are to be installed below this type of floor, the planner will have to ensure that sufficient clearance exists.

Some false floor voids are 'cable-managed' by the provision of two or three compartment trunking. It will be rare that any use of this can be made by Baseband cable installers as it is not normally possible to house MAUs within the confines of the trunking. Unless it is against some local code, it is acceptable to 'loose-lay' the network cables under such floors, provided that they are secured to the floor support uprights at 2-3 m intervals.

### **3.3.8 Wall Trunking**

Wall trunking needs to be large enough to house both cables and MAUs.

Where trunking routes follow the contours of buildings, slow gusseted bends may be required to allow for the minimum bending radius of the cables.

### **3.3.9 Hazardous Environments**

Optical fibre cables can be used to connect Repeater units. Due to its non-conductivity and other unique properties, fibre cable will enable the installation of the network to be continued through an area with a hazardous environment where normal coax may be unsuitable, such as:

- subject to electrical noise;
- subject to extreme temperatures;
- requiring bend radius less than that applying to coax;
- through structures requiring the minimum of removed material;
- high security paths;
- where unprotected from lightning;
- subject to sudden changes in local earth potential, eg. on power station sites during fault conditions.

### **3.3.10 Electrical Noise**

High power electrical plant produces switching transients and radio frequency emissions that may induce interference on the Trunk Cable. Planners should ascertain the location of any such interfering devices from the Site Services Manager.

A minimum separation of 10m is recommended between the network cables and a source of high energy emissions such as lift relays, electric arc welders, a.c. substations, generators, etc.

Due to the construction of the cable and the error detection/recovery capabilities of the Baseband System, electrical noise will not normally produce data errors in the system, perceptible to the user, provided the 10m separation is observed.

### **3.3.11 Mains Voltage Supplies**

Do not install any of the hardware between areas supplied by more than one medium voltage (ie greater than 450 V rms) mains feeder without certification from the customer that the power transformers have been equipotential bonded in accordance with prevailing electrical regulations. Areas that are not equipotential bonded may be joined via a FOIRL (Fibre Optical Inter-Repeater Link).

### **3.3.12 Lightning Protection**

The building that will house the Network must have sufficient protection to safeguard its contents from lightning. Reassurance on this matter should be sought from the customer, but if in doubt consult a specialist in lightning protection, and advise the customer of the risks he runs should his building be struck.

In this respect, special attention should be given to a network spanning more than one building. In this case the use of FOIRL should be considered.

### **3.3.13 Site Access and Safety**

It is most important to ascertain when installation work can be carried out, e.g. during normal working hours, during the week but after hours or will weekend working be required? This factor will have a major impact on the price of the installation and should not be overlooked on the site visit.

Coupled with this is a question of the safety of installation staff working on the site after normal working time. Assurances should be sought from the customer on this point.

### 3.4 Plans

Once the Site Survey has been completed, and the building structure has been evaluated to determine which type of cable will be used and where (above the ceiling, under the floor etc) the System Plans should be drawn up by the Implementation Manager, as follows:

#### 3.4.1 Floor Plan

Obtain a clean set of floor plan of the area to be cabled from the facilities' manager, architect or other appropriate source. Alternatively, a sketch can be drawn and the appropriate measurements noted.

The floor plan will be used to show the layout of the Trunk Cable between devices and will allow its total length to be calculated. This will help to determine the size and quantity of Trunk Cable to order, as well as the other network components that will be required. Remember to include vertical lengths of cable routes.

#### 3.4.2 Schematic Layout

Examples of Baseband schematics are shown in Appendix B. While a schematic cannot show detailed placement of DTE, MAUs, and Drop Cables, it can give a 'snap-shot' of a network and can help determine the following:

- how many sections of cable are required to make up a given segment of Trunk Cable;
- how much cable is required/used;
- if multiple segments or repeaters exist;
- the number of barrel connectors used;
- the number of floors the LAN serves;
- the amount of stores required for the installation;
- whether expansions to the network are possible.

The schematic is created from information obtained from the floor plan layout. While floor plans should also show the equipment locations and a close approximation of the Trunk Cable within the building, the schematic is useful in summarizing and cross checking the network component order.

#### 3.4.3 Identify DTE Locations

Identify planned and future user devices on the floor plan, for cable layout planning purposes. When planning the positions of the DTE, the following factors should be considered:

- the equipment should be readily accessible to both Users and support personnel and should be sited such that it does not contravene prevailing Health and Safety legislation;
- the type and length of the Drop Cable to be used determines the distance from DTE to the Trunk Cable. In the early planning phase allow 4,5 m for false ceiling installations, and 1,5 m for underfloor installations;
- include the vertical rise when determining the distance from the DTE to the MAU, and make a horizontal allowance for equipment movement for service or repair;
- remember the maximum length of Drop Cable for each MAU should not exceed 50m, and consist of no more than two sections (see 2.1.10);
- the Product Description for a DTE will give power, heat dissipation and space requirements.

The location of MAUs should be correlated using a Time Domain Reflectometer (TDR) map of the Cable System taken when the installation is completed (see Appendix C). Unauthorised MAU installations can then be identified by subsequent TDR mappings.

#### **3.4.4 Identify Cable Routes**

Factors to consider when planning the Trunk Cable sectioning are:

- a 10BASE5 Trunk Cable segment must not exceed 500 m (185 m for 10BASE2);
- the area of network coverage, including the probable location of intersegment repeaters, should be determined;
- it may be more cost effective when covering larger floor areas to use longer AUI Cables and/or Transceiver Multiplexers, rather than to make extra Trunk Cable runs, thus resulting in fewer repeaters being required;
- the signal information carried on the Trunk Cable is very low energy (low voltage and low electrical current). Optimum performance is achieved by ensuring that the cable does not run closer than 10m to any source of high energy emissions, ie lift relays, electric arc welders, a.c. substations etc;
- plan sections of Trunk Cable with connectors/terminators conveniently located in serviceable areas for ease of installation and maintenance;
- avoid locating connectors in risers or in conduits as they may become "buried". If this is not possible, suitable boxes should be installed to house the connectors, thus ensuring ease of access.

#### **3.4.5 Identify Locations Of Baseband Components**

Mark the floor plan with the optimum location of Terminators, Repeater, Connectors, MAUs and AUI Cables and award them unique network identification codes in accordance with the component symbols as shown in 2.2.4. This information should also be recorded on the schematic diagrams. Installation staff require this information when labelling the network.

#### **3.4.6 Calculate The Length Of Trunk Cable**

Using the floor plans, calculate the length of Trunk Cable required to ensure accessibility to the equipment. Allow additional Trunk Cable to route round obstacles and for other contingencies. Remember vertical lengths of cable must be included in all such these calculations.

Where the length of Trunk Cable exceeds the permitted maximum for its type, a repeater will be required to ensure reliable Network performance. Ideally this repeater should be sited such that it splits the route approximately in half, thus allowing the system to grow in either direction. Remember the repeater will require mains power to function.

#### **3.4.7 Total The Network Components**

Using the schematic layouts, the planner can total up the components that will be required for the installation. A useful form to aid this task is to be found in Appendix E, and should be copied for use. The planner should include this information in the Installation Engineer's Works Instructions.

#### **3.4.8 Installation Engineer's Works Instructions**

To enable the Installation Engineer to be able to install the Baseband Network as planned, it is necessary to explain the proposed system to him in great detail. The following information documents must be passed on:

- all floor plans;
- schematic network diagrams;
- blank copies of floor plans for 'as built' information;
- component lists;



- labelling requirements;
- references to relevant recipes;
- specific site information, regarding for example:
  - . permitted working hours;
  - . special safety codes;
  - . preparation work to be undertaken by the customer prior to installation (provision of main power supplies, trunking, holes through walls, etc).

When handing over the network plans, it is essential to visit the site again and walk over the proposed cable routes with the Installation Engineer, to improve understanding.

#### **3.4.9 Schematic Layout Examples**

The schematic diagrams in Appendix B are examples of typical Baseband cable installations. The network symbols in 2.2.4 should be used when producing these diagrams.

As stated in 3.4.2, the schematic is created from information obtained from the floor plan layout. It is not proposed that schematics be drawn to scale.

#### **3.4.10 Labelling of Equipment and Cables**

In order to maintain the installed network, it is essential that all major components (MAUs, transceiver multiplexers, repeaters), cables (trunk and AUI), and access units (data ports etc) are all clearly labelled in strict compliance with the design plans.

All NEW equipment (MAUs, transceiver multiplexers, repeaters), should be marked with the installation date for warranty purposes.

#### **3.4.11 Drawing Office Procedures**

Final copies of the 'as built' floor plans and schematics must be sent to the Network Planner who should amend the master copies accordingly and distribute copies of the final drawings to those people the planner identifies, i.e. to himself, the customer, the engineers responsible for the support of the installation, the network support group.

It is very important that no two Local Area Networks are allocated the same Network ID as future internetworking will depend on all networks having unique numbers for routing information.

### **4. NETWORK SYSTEM INSTALLATION**

#### **4.1 Introduction**

As performance specifications are stringent, the installation, equipment connection and maintenance must only be performed by trained technicians.

This Clause:

- describes the installation procedures for Baseband cable system components;
- gives a procedure for testing and accepting the installed cable system components;
- describes the procedure for connecting User Devices to the Baseband components.

#### *NOTE 4*

*It is not intended to cover the installation of the range of available baseband interface equipment in this document. These procedures will be found in other documents.*

## 4.2 Standards and Specifications

The installation of the Baseband Cable hardware shall conform to ISO 8802-3 and ECMA-97. Deviation from these Standards may cause performance degradation or render the network dangerous. In addition all local codes and regulations should be obeyed where applicable.

Furthermore installation of the Baseband cable systems must be in accordance with the marked floor plan, as agreed with all parties concerned.

The locations of all connectors, Terminators, MAUs and AUI cables must be marked on floor plans during installations. This will produce 'as built' floor plans, which may differ from the original specifications. These plans are to be sent back to the Network Planner after the completion of the installation.

## 4.3 Trunk Cable Installation Instructions

The following points should be observed when installing Baseband Trunk Cable:

- carry out the 'on-drum' continuity test (5.3.1);
- 10BASE5 Trunk Cable must not have less than a minimum bend radius of 254 mm when installed or during installation. (For 10BASE2 installations this reduces to 50 mm);
- trunking and conduit used for 10BASE5 Trunk Cable must have slow gusseted bends of radius 300 mm minimum. (100 mm for 10BASE2);
- at installation care should be taken to ensure that the Trunk Cable is not compressed, crimped, crushed, kinked or stretched during installation;
- the Trunk Cable sheath must not be damaged or cut in any way to expose the metal screen;
- protection should be provided against sharp edges or possible damage caused by work being carried out in the vicinity of the Baseband cable routes during the installation phase;
- Trunk Cable should be separated from radiating energy devices (ie high current switches and r.f. transmissions) by at least 10 m;
- Trunk Cable spanning an open area, are required to be supported at least every 3,0 m. Vertical sections also require to be secured at approximately 3 m intervals;
- MAUs should be supported in a suitable bracket;
- excess Trunk Cable should be coiled (254 mm minimum radius) close to the terminated ends. (100 mm minimum for 10BASE2);
- where possible Trunk Cable must rest directly on a flat supporting surface to minimize the risk of sharp bends or kinks;
- when installing any Trunk Cable in conduit, MAUs, connectors and Terminators must be installed such that they are accessible, possibly by the addition of a suitable housing;
- for Trunk Cable installations above ceiling, access to connections Terminators and MAUs should preferably not require moving more than a single, easily removable section of the ceiling or reaching more than 300 mm from the opening;
- conduct Test No 2 (5.3.2);
- both ends of the cable need to be clearly marked with the segment identifying letter (A-ZZZ). This letter is allocated by the designer and can be found on his plans.

NOTE 5

Sharp bends in the Trunk Cable or continuous movement due to mechanical disturbances may damage the dielectric material, causing the centre conductor to migrate to the outer screen, resulting in discontinuity causing unacceptable reflections and subsequent system failure.

4.4 Connector Installation

Where possible, connectors should be installed within 3 m of the floor, and clearly labelled.

The location of all connectors should be marked on the 'as built' floor plans.

Carry out Installation Test No 2 (5.3.2).

4.4.1 N Series

i) N-Type Plug Connector

Two styles of N-Type male plugs may be encountered when terminating 10BASE5 cable. One has a soldered centre pin and a bolt up back nut, but inherent dangers accompany the use of solder, including; damage to the cable; varying quality of resultant joints; operator injury; fire hazard etc.

The preferred option is of the crimp variety. Not only do these overcome the points above, in that the high quality of termination is repeatable and are not harmful to cable, operator or building, but crimp plugs are cheaper to install.

Below is the cable trimming and fitting information for N-Type Plug Connectors.

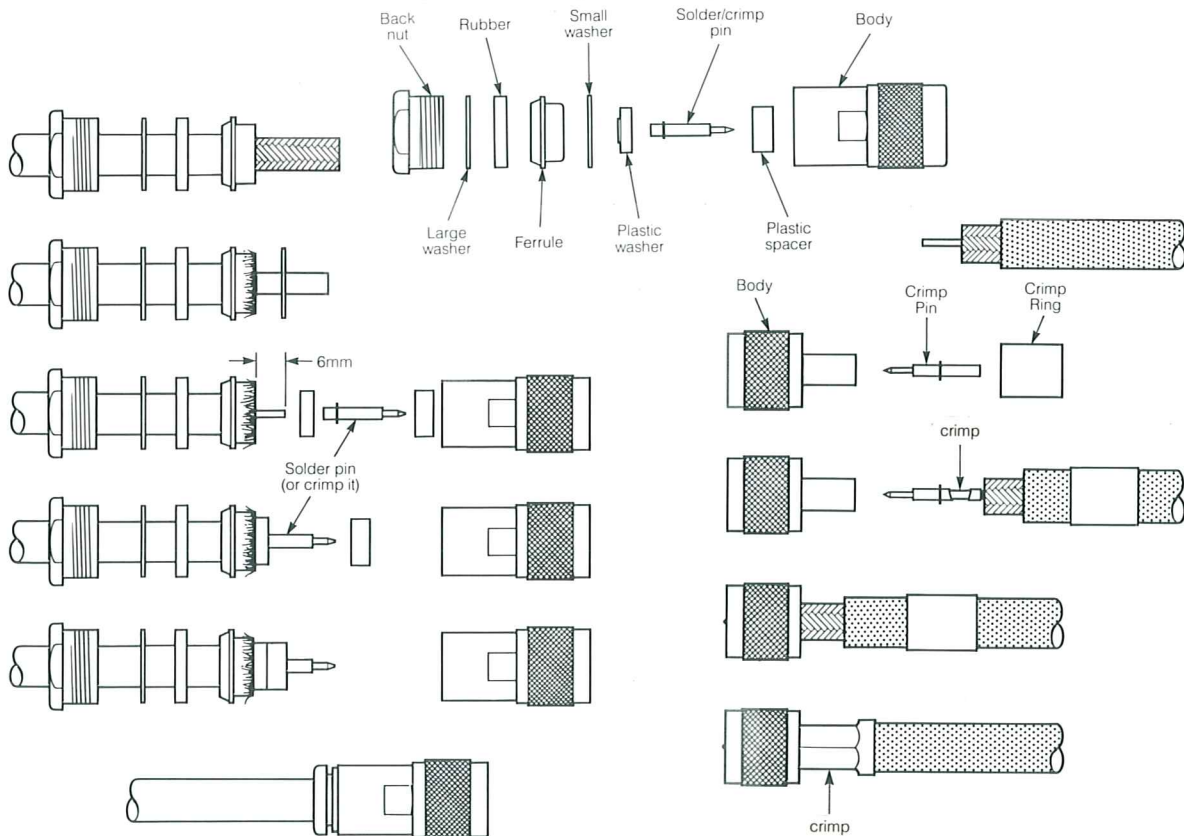

Figure 21 - N-Type Plug Connectors Typical Fitting Instructions

ii) N-Type Barrel Connector

To install an N-Type Female to Female Barrel connector, simply locate the terminated ends of the two cable sections to be joined together and screw the splice home. Use hand pressure only to tighten these connectors.

Insulate barrel and connectors with a suitable insulating boot.

4.4.2 BNC Series

i) BNC Plug Connector

The type of male BNC plugs encountered in 10BASE2 Baseband cable installations are usually of the crimped variety. Below is the cable trimming and fitting information for this connector type.

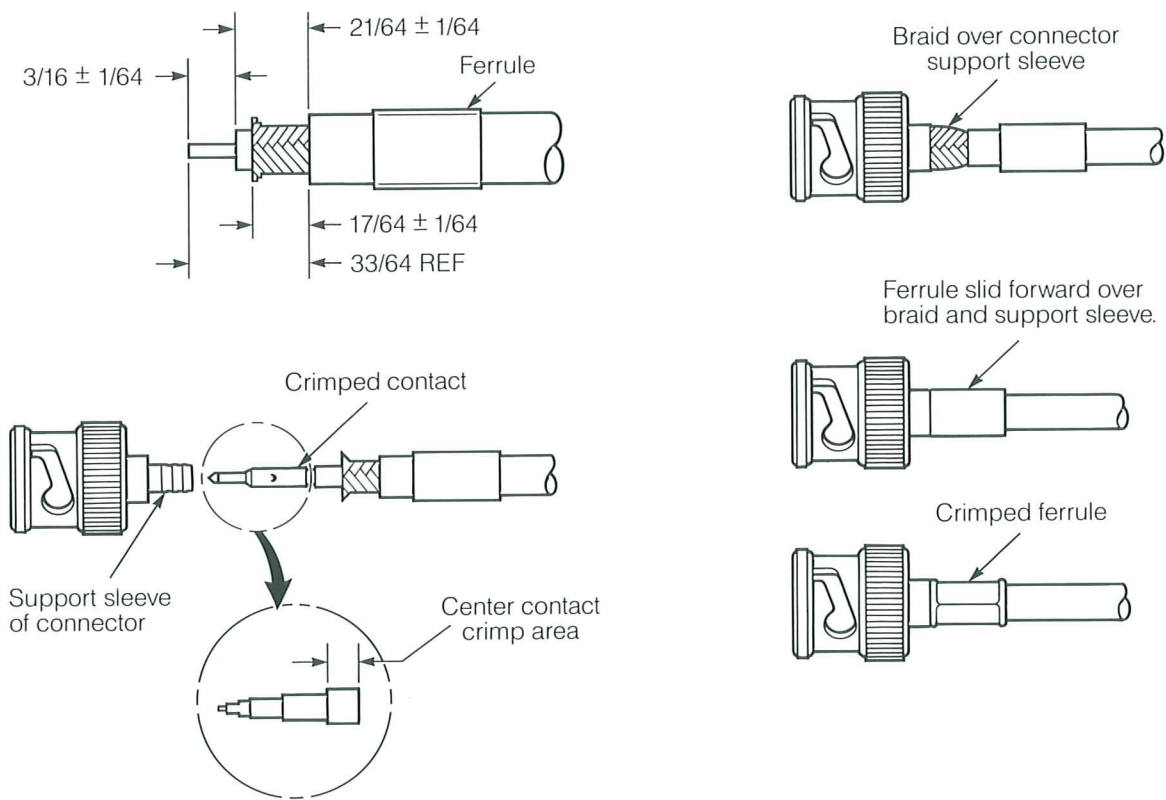

Figure 22 - BNC Plug Connector Typical Fitting Instructions

ii) BNC Barrel Connector

These connectors are used join two 10BASE2 cable sections together. Future MAU placement can be anticipated by their use during the planning stage. This will reduce the 'down time' when these connectors are replaced by either a BNC Tap or a BNC 'T'-pieces when subsequently inserting MAUs.

iii) BNC T-Piece Connector

As stated above, these clip together two sections of 10BASE2 cable and offer a network connection to MAUs equipped with BNC female bulkhead connectors.

It is good practice for unused or "freed" 'T'-pieces to be removed from the cable (provided the unavoidable break in service can be tolerated) and replaced with female-female barrels. If this action is not taken, due to the imminent fitting of a MAU for example, it is quite in order to leave the third (male) connector 'in line' and unterminated provided it is insulated inside a BNC Connector Shroud and its location recorded.

CO-AXIAL DROP LEADS BETWEEN 'T'-PIECES AND MAUs ARE NOT ALLOWED. If it is necessary to divert the trunk cable route in order to serve a new location then follow the relevant procedures in 6.2.

Ensure that the location of all connectors are marked on the 'as built' floor plans.

#### **4.5 Terminator Installation**

##### **'N' Terminator**

To install a type N Terminator, first locate one of the free ends of the cable segment, which should be complete with a male connector and segment identification label.

Sufficient slack should be left at the terminated ends of the segment to allow the ends to be brought within easy reach of floor level to facilitate Time Domain Reflectometer (TDR) testing.

Carry out Installation Test No 2 (5.3.2).

Take a suitable terminator and screw it home using hand pressure only.

Ensure the exact location of the terminator is recorded on the 'as built' floor plans.

If the plans show that this terminator has been elected to be the earthing location for this cable segment then proceed to 4.6.

Insulate the Terminator and Connector with a suitable boot and label the end in accordance with the schematic network diagram.

Repeat this procedure at the other end of the cable segment.

##### **BNC Terminator**

BNC terminations must be fitted, one each end of the segment, on the last T-piece or BNC tap of the segment.

Carry out Installation Test No 2 (5.3.2).

Take and fit a BNC terminator, using hand pressure only.

Ensure the exact location of the terminators are recorded on the 'as built' floor plans.

#### **4.6 Earthing Arrangements**

The outer screen of each 10BASE5 cable segment must be earthed once only.

An Earthing Clip provides a means of attachment to a barrel connector, and should be cabled and connected to the nearest mains electrical earth distribution point in accordance with ECMA-97. Local electrical codes must be observed when installing earths.

The earth offered by the customer should not exceed eight ohms. If in doubt this should be checked and if necessary brought up to the required standard. (The earth on the nearest mains socket is not good enough.)

A suitable insulating shroud should be used to ensure that the connector shell and earth clip are insulated from any casual earths.

Label the cable ends in accordance with the schematic network diagram.

**NOTE** The local earth on equipment is isolated from the Trunk Cable earth at the MAU.

### WARNING

#### Removal of Segment Earth

To avoid the possibility of electrical shock, before removing the earth connection, it is recommended that the voltage on each conductor or exposed screen be measured with respect to local earth potential. If more than 30 V a.c. is detected, a fault exists and must be rectified before proceeding.

#### 4.7 Tap Connector Installation Instructions

##### 4.7.1 MAU Tap for 10BASE5 Cable

###### Assembly Procedure

- 1 Determine tapping location on cable. (remember MAU taps may only be placed at the 2,5 m marks found on the sheath.). Where possible, MAUs should be within 3,0 m of the floor.
- 2 With ground probes inserted into one half of the tap body, locate the cable in the channel of the tap body.
- 3 Connect the other half of the tap and secure the two halves together.
- 4 Using a coring tool, designed to be used with the tap in question, drill through cable to centre conductor.
- 5 Inspect the hole to be sure no particles of shield or other matter remain in the hole, then fit the probe assembly into the tap body.
- 6 Carry out Installation Test No 3 (5.3.3).
- 9 Fit a protective cover over the tap's connector then mark it's location on the 'as built' floor plan.

##### 4.7.2 BNC Tap

Where BNC Tap connectors (see Figure 11) are to be used on 10BASE2 cable installations, they will allow for fast installation of the tap into cables that have been pre-terminated with BNC male plugs. Additionally, they allow 10BASE2 cable systems to connect the same MAUs as 10BASE5 installations, being equipped with both braid and probe connectors. Carry out Installation Test No 4 (5.3.4), at the time of fitting.

Some 10BASE5 MAUs are electrically compatible with both 10BASE5 and 10BASE2 cable systems, some are not. Check the specification of the MAU before using it on either system.

#### 4.8 MAU Installation

##### 4.8.1 MAUs with Tap Connectors

Three types of tap will be encountered in Baseband cable schemes, one is the piercing type described above, another has BNC connectors for use with 10BASE2 cable systems (Figure 11) and the other is similar to the BNC tap but is equipped with N-Type connectors. All three types however, fit into MAUs in the same way.

Having first removed the cover, and carried out Installation Test No 3 (5.3.3), (or Test No 4 (5.3.4)), align the probe and ground probe posts with contacts on the pcb within the MAU, then carefully push both units together. Secure tap body to MAU with the screws and nuts

provided (see Figure 23). Isolation from casual earths has been designed into both tap and MAU, making further insulation unnecessary.

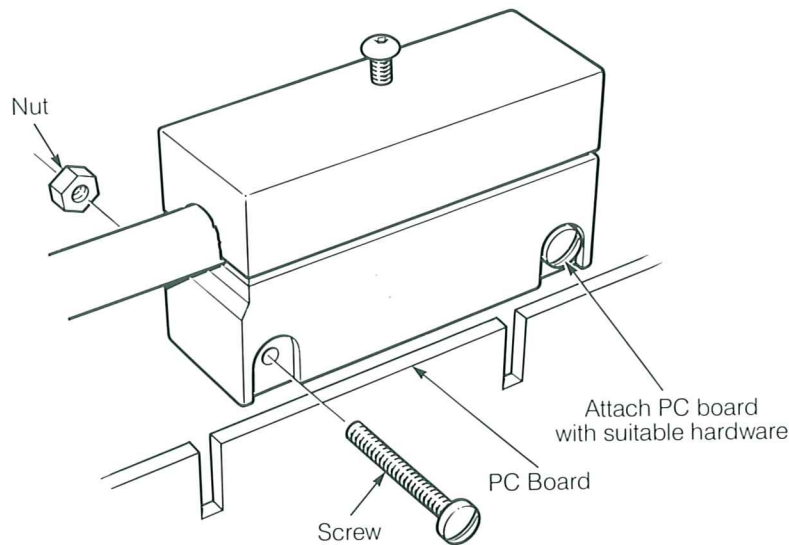

Figure 23 - Fitting MAU Taps

#### 4.8.2 MAUs with BNC Connectors

As stated in 2.7.1(ii), some interface boards incorporate an on-board MAU. These cards do not require Taps as they come complete with an integral female BNC bulkhead connector. To install this type of MAU:

- configure and install the interface board card according to the manufacturers instructions;
- prepare the location as described in 4.4.2 and 6.2 (if necessary). It is important, for the reasons given in 2.1.4 that the Network Manager is aware that this type of work is being carried out;
- insert a BNC T-piece into the male plugs;
- carry out Installation Test No 5 (5.3.5);
- do not use a co-axial drop lead, clip the T-Piece directly onto the interface board card;
- label the cable adjoining the MAU with the code allocated to the MAU/card/node as stipulated on the network schematic drawing;
- ensure that the location of the MAU is marked on the 'as built' floor plans.

Many 10BASE2 MAUs are manufactured as discreet components and are equipped with a female BNC connector.

#### 4.9 AUI Drop Cable Installation

Installation of pre-terminated AUI cables will present the installer with little or no problems (provided the 15 pin D-type connectors will pass through the chosen cable route and precautions against forming links in the cable are taken!). Simply offer up to the MAU the female socket end of the AUI cable. The male plug of the cable will mate with the DTE device.

**WARNING**

**THE DTE DEVICE TO BE CONNECTED SHOULD BE SWITCHED OFF  
BEFORE CONNECTING THE AUI CABLE TO THE MAU,  
OTHERWISE EQUIPMENT MAY BE DAMAGED.**

Secure both ends to their host using the slidelock mechanisms provided.

Pre-made AUI cables are often available in a range of preferred lengths:

Should it be necessary for installation engineers to terminate AUI cables themselves, the pin-out detail they will require will be found in Table 2. Additionally it should be noted that:

- each twisted pair shall remain twisted right up to their termination at the D-type connector;
- both connector shells shall be of the screened type and must be firmly grounded to the outer screen of the ISO 8802-3 cable (see Figure 15 and Figure 24);
- the four individually screened pairs are conductively coupled to one or more earth Drain Wires. These wires must be terminated on Pin 4 of both connectors. Furthermore, Pin 4 shall be coupled to Pin 1 to meet ISO 8802-3. Some implementors also extend the earth to pins 8, 11 and 14 using short loops of flexible, insulated wire (see Figure 24). These earth straps must not be allowed to short circuit to the outer screen. RFI or malfunctions will result if this is not observed;
- both ends of the cable should be clearly marked with a unique identifier and the location/device/port no of the distant end. If these cables are subsequently moved remember to alter the labels to reflect their new locations/devices/port number, etc.

MAU End (Female socket) Pin No		DTE End (Male plug) Pin No
Conductive Shell 1/4 (8/11/14 optional)	Outer Screen Inner Screen	Conductive Shell 1/4 (8/11/14 optional)
2		2
3		3
5		5
6		6
9		9
10		10
12		12
13		13

**Table 2 - AUI Pinout Details**

**NOTE 6**

*The inner screens must be allowed to short circuit to the outer screen.*



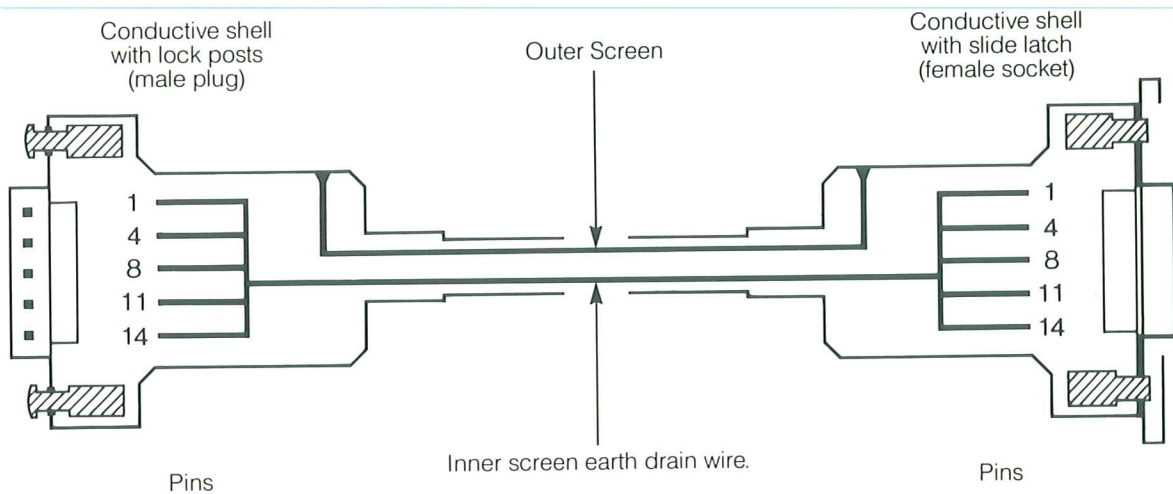

Figure 24 - ISO 8802-3 AUI Cable Shielding

#### 4.10 Data Port Kits Installation

When installing Data Port Kits (see 2.1.11) the following shall be ensured:

- the end of the AUI cable enclosed in the Data Port should be enclosed in a screened connector shell (e.g. steel case);
- the AUI Cable must be securely clamped to prevent it from pulling its connection outside the data port screen.
- that the outer screen at the AUI cable is isolated from steel cased Data Port Kits.

If the above is not observed, the connection will allow ingress and emission of electro magnetic interference and seriously degrade the signals on the AUI Cable cable.

The choice of Data Port design resides ultimately with the customer, after all, it is his building, he should decide how and where these port are presented. It may be necessary to make them up locally or incorporate them into existing service access positions, e.g. floor traps. Guidance should be sought from the customer at the earliest opportunity. Standard Data Port Kits are available and can be provided if the customer has no objection to their use.

All Data Ports must be clearly labelled (see Appendix B for details)

### 5. INSTALLATION TEST

#### 5.1 Introduction

The integrity of the Baseband Cable Network hardware is crucial to the performance and reliability of the System. It is, therefore, of utmost importance that the quality of the installation is ensured and proved by the results of rigorous testing.

The importance of Cable Network cable testing cannot be overstressed.

This section:

- describes why rigorous and exhaustive testing is required;

- details the tests and procedures that are required to ensure that the cable network is continuous and functional.

## 5.2 The Need for Rigorous Testing

The characteristics of a network consisting of a number of joined lengths of Trunk Cable, together with associated cable components shall be as close as possible to those displayed by an equivalent, unbroken length of Trunk Cable.

All joints and terminations in the cable network are points of discontinuity at which signal reflections will take place, thus causing standing waves on the line. Badly formed joints and terminations will cause reflections of an unacceptable level. Standing waves will cause the Data Network to fail, so they are to be avoided.

## 5.3 Installation Checks

This section is intended to assist with the commissioning and maintenance of a Baseband Cable Network, for both 10BASE5 and 10BASE2 cabling systems.

In order to test the cable installation successfully, it is necessary to use a Time Domain Reflectometer (TDR) for the majority of the testing (see Appendix C). The use of a Digital Multi-Functional Meter (DMFM) with an accuracy of 1% is also recommended.

The tests described in this section are:

- |        |  |
|--------|--|
| Test 1 | Pre-Installation Checks on Trunk Cable Media   |
| Test 2 | Post-Installation Checks on Trunk Cable Media  |
| Test 3 | Installation Checks on 10BASE5 Piercing Taps   |
| Test 4 | Installation Checks on BNC and N-Type MAU Taps |
| Test 5 | Installation Checks on 'T'-Piece Connectors    |

### 5.3.1 Test 1 - Pre-Installation Checks on Trunk Cable Media

It is advisable to carry out a continuity test on the cable, prior to installation and before removal from the drum, as follows:

- ensure both ends of the cable on the drum to be installed are accessible;
- strip cable and short together the inner conductor to the outer screening braid at one end of the cable;
- strip cable and measure the resistance between the inner and outer conductors at the other end of the cable, using a DMFM;
- given that:

10BASE5 Trunk Cable has a resistance of 1,0 ohm/100 m

10BASE2 Trunk Cable has a resistance of 5 ohm/100 m

confirm by electrical measurement that the length of the cable corresponds to the manufacturer's stated length (to be found printed on the drum);

- to prove that a true reading has been obtained, remove the short from the cable and measure again. This time an open circuit indication should be found.

NOTE: Anything other than an open circuit will automatically reject the drum of cable under test.

Remember:

Maximum permissible length (cables with connectors):

- 10BASE5 = 500 m (1640 ft) (5 ohm DC loop resistance)

- 10BASE2 = 185 m (407 ft) (10 ohm DC loop resistance)

### 5.3.2 Test 2 - Post-Installation Checks on Trunk Cable Media

After the cable has been installed:

- but before connectors and terminators are installed, Test 1 should be repeated. Similar readings should be obtained as in Test 1, suitably adjusted for the length of cable used;
- install a suitable 50 ohm Connector and Terminator to one end of the cable ('a' end);
- at the 'b' end of the cable, use a DMFM to measure the terminated loop resistance between the screen and centre conductor. This should be 50 ohms plus the unterminated loop resistance as measured at the start of this test;
- if this reading is not obtained, check the termination at the distant end for correct installation (see 4.5);
- having obtained the correct result from the above tests, fit another connector and terminator to the 'b' end;
- remove the terminator from the 'a' end and repeat the last four steps, this time replacing 'a' for 'b' and 'b' for 'a';
- ensure all the terminators are installed, earthed and insulated in accordance with section 4.6 of this guide.

### 5.3.3 Test 3 - Installation Checks on 10BASE5 Piercing Taps

Assuming 10BASE5 Trunk Cable has been installed and satisfactorily tested, assemble the 10BASE5 Piercing-Tap connector as instructed in 4.7.1. The following test of the tap installation should then be carried out before attaching the MAU to the Tap (4.8.1). Using a DMFM measure the resistance between:

- Braid Terminators (correct reading = full short)
- the Probe Assembly and one of the Braid Terminators.

(Assuming a cable length of 500 m, a reading of 26,5 ohm  $\pm$  1,5 ohm should be obtained. A cable length of 100 m should result in a reading of 25,5 ohm  $\pm$  0,5 ohm)

If a short circuit reading is obtained between the ground probes and the centre Probe, then remove the centre Probe Assembly and inspect the bore-hole. It is most likely that some waste screen material remains, which should be cleared out.

If open circuit readings are obtained, check that the Tap Connection has been correctly installed. Such readings could be caused by the following:

- the tap may not have been tightened enough, thus preventing the ground probe terminators from penetrating the cable sheath.

Remedy: check the tightness of tap clamp but do not over tighten as damage to clamping mechanism may result (stripped threads, etc);

- insufficient material removed due to a damaged coring tool, leaving too much cable dielectric, thus preventing the centre Probe Assembly from making contact with the inner conductor.

Remedy: re-bore using an undamaged tool;

- insulation debris blocking the bore hole, again preventing the centre Probe Assembly from making contact with the inner conductor.

Remedy: clear debris from hole;

- Probe Assembly not seated properly.

Remedy: check and re-tighten if required;

- Probe Assembly broken.

Remedy: check and replace if required.

- Cable constructed with too large an outside diameter, causing the probe to stop short at the centre conductor.

Remedy: check outside diameter at cable and replace it if it proves to be out of specification ( $10,3 \text{ mm} \pm 0,3 \text{ mm}$ ).

#### 5.3.4 Test 4 - Installation Checks on MAU, BNC with connectors

It is wise to remember that severing or disconnecting 10BASE2 Trunk cable will cause a working network to fail. Ensure that the customers' Network Manager is aware of and is in agreement with this type of work being carried out before commencing.

Proceed as follows:

- install two BNC male plug connectors at the desired location, as detailed in 4.4.2;
- using a DMFM, measure the loop resistance between the centre conductor and the screen of each BNC male Connector in turn.

(Assuming a cable length of 185 m, readings of  $52,5 \text{ ohm} \pm 3,0 \text{ ohm}$  should be obtained. With a cable length of 100 m a reading of  $51,5 \pm 2,0 \text{ ohm}$  should be obtained);

- following the instructions as detailed in section 4.7.2, install a "pre assembled" MAU Tap. (see also Figure 10);
- before attaching the MAU to the Tap, 4.8.1, use a DMFM and measure the resistance between the grounding probes (the two outer pins). The correct reading is a full short;
- measure between a ground probe and the central 'Probe' pin. Readings of  $26 \text{ ohm} \pm 2,0 \text{ ohm}$  should be obtained for a 185 m maximum length cable.
- If an open, or short circuit reading is obtained, remove the "pre assembled" MAU Tap and check for continuity. If the item is faulty then replace it with another and retest. If the fault persists, re-check the BNC Connectors on the cable.

#### 5.3.5 Test 5 - Installation Checks on 'T'-Piece Connectors

Once again remember that severing or disconnecting 10BASE2 Trunk cable will bring a working network to a halt. Be sure that the customers' Network Manager knows and agrees that this type of work is to be carried out BEFORE commencing.

Proceed as follows:

- install two BNC male plug connectors at the desired location, as detailed in 4.4.2;
- using a DMFM, measure the loop resistance between the centre conductor and the screen of each BNC male Connector in turn;

(Assuming a cable length of 185 m, readings of  $52,5 \text{ ohm} \pm 3,0 \text{ ohm}$  should be obtained. With a cable length of 100 m a reading of  $51,5 \text{ ohm} \pm 2,0 \text{ ohm}$  should be obtained)

- connect the BNC 'T'-Piece Connector to the two male plugs;
- using a DMFM, measure the loop resistance between the centre conductor and the screen of the BNC Connector;

(Readings of 26,5 ohm  $\pm$  2,0 ohm should be obtained. These readings assume a cable length of 185 m)

If an open, or short circuit reading is obtained, remove the BNC 'T'-Piece and check it for continuity. If the item is faulty, replace the Connector with another, and retest. If the fault persists, re-check the BNC Connectors on the cable.

#### **5.4 Acceptance Checks/Tests**

##### **Responsibility**

The Implementation Managers are responsible for all acceptance checks and tests on baseband cable networks. Using the site plans, these engineers will make a physical inspection and check that:

- the installation matches the customer approved plan;
- all cables and associated connections are marked as specified and their exact locations recorded on the 'as built' floor plans;
- the installation meets all specifications;
- verify integrity of cable by performing the acceptance tests below;
- arrange for, and re-check, any remedial work needed to be carried out.

##### **5.4.1 Trunk Cable**

The simplest Baseband Cable Network will consist of one continuous run of Trunk Cable (see Appendix B). This should present no problems regarding points of discontinuity. TDR tests can only be carried out on a per segment basis as the TDR signals do not pass through repeaters.

When tested with a Time Domain Reflectometer (TDR), it should display no step on the TDR's display. If the 50 ohm Terminator had been omitted from the Trunk Cable end, there should be a very definite upwards step response on the TDR, indicating an open circuit. On the other hand, a definite downward step indicates a full short condition exists.

Any reflection of amplitude greater than 4% will constitute an automatic rejection of the cable network. Using the distance readout, the location of the fault may be identified and remedial action taken.

If the reflection is caused by a poor joint, the faulty connector(s) shall be replaced.

If reflections are caused by mechanical damage to a Trunk Cable section, it must be replaced by cable with the same characteristics, ie of the same drum as that installed. Alternatively, if the damage is small and sufficient slack exists, a barrel connector and male plugs could be used. If this action is taken then the position of the connectors shall be noted on the 'as built' diagrams.

##### **5.4.2 MAUs and AUI Cables**

The proper functioning of MAUs, and AUI cables will be verified by confirming successful transfer of data packets using two DTE's, or alternatively by special test equipment. With respect to most PC LANs, this test would entail the successful attachment of a PC to a Network Server on the same cable segment. The initial test should be carried out on the AUI cable at the extremities of the Trunk Cable segment. Having thus verified the functionality of the network overall, the test will be carried out on the remaining AUI cable installations. An acceptable test criterion is that all PC's can log on to their host servers from all access points on the network (ie at each AUI Cable).

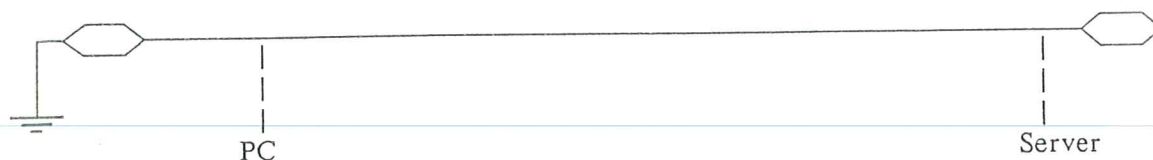

Figure 25 - Set Up for Testing a New Cable Segment

### 5.4.3 Repeaters

It is recommended that a PC, equipped with an interface card, be placed on one segment and its server to be on the other segment served by the repeater under test. By carrying out the same connectivity test as above. The same test criterion will apply.

All Repeaters require an a.c. power source, so, before failing the installation, check that the repeater under test is switched on!

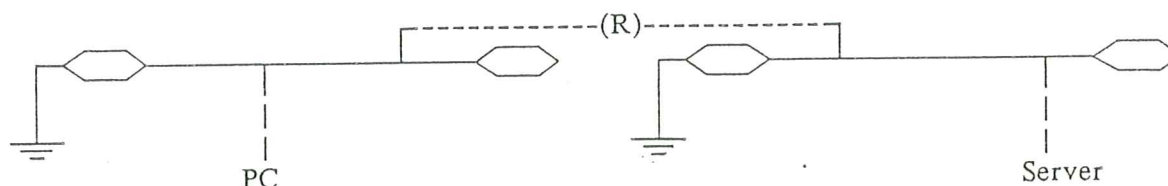

Figure 26 - Set Up for Testing a Repeater Set

## 6. RECONFIGURATION & EXPANSION OF A BASEBAND CABLE NETWORK

### 6.1 Introduction

The flexibility of the Baseband Cable Network scheme permits both reconfiguration and evolutionary growth of the system.

The passive nature of the 10BASE5 cable networks allows DTE to be removed or relocated without affecting the operation of other network users. This benefits the User in terms of scheduled/unscheduled maintenance, and provides the flexibility to relocate equipment in any new area within reach of the LAN cables.

This section describes possible ways of expanding an installed cable network, and provides the planner with guidelines for:

- Baseband Cable Network expansion;
- DTE expansion and/or relocation together with the associated MAUs.

### 6.2 Baseband Cable Network Expansion

When there is a need to install or relocate a DTE in a new location which is beyond the range of the existing Trunk Cable, even when the maximum permissible length of AUI cable is used with Trunk MAUs (or if co-axial 'on-board' MAUs have to be installed) the Trunk Cable system shall be expanded to meet the need.

Expansions shall be planned and installed according to the procedures described in Clauses 3 and 4, and the floor plans and schematics must be edited to reflect the changes.

Strict observation of the rules is essential, in particular:

- the provision of one earth connector per segment;
- that no two segments may be physically joined more than once (e.g. no loops);

- that segment lengths must not exceed the permitted maximum for their type;
- that the expanded Trunk Cable segment is not required to support more than the permitted number of MAUs for the medium used (100 max 10BASE5, 30 10BASE2);
- that the expanded network is not required to support more than the permitted number of DTEs (1024).

A TDR map of the extension should be marked-up to identify added features and attached to the existing TDR maps with modified floor plans and schematics.

A Baseband cable expansion can be achieved in one of three ways:

- extend one or more ends of the Trunk Cable segment;
- add a new segment of Trunk Cable and link it to the existing segment using a Repeater;
- insert extra Trunk Cable in an existing segment.

#### **6.2.1 Extending the End of a Segment**

This simple operation entails moving the Terminator to the end of the new length of Trunk Cable. Note the system will go down as soon as the Terminator is removed so make sure you have the approval of the customer's Network Manager before you start.

The following procedure can be applied to either 10BASE5 or 10BASE2 trunk cables:

- obtain and install the required length of cable with connectors and terminators installed on each end. The cable used should be of the original batch. (If this is not possible then the expansion shall be made as in 6.2.2). Obviously, one end of the extension cable must be installed adjacent to a terminator of the existing cable segment;
- carry out Installation Tests No 1 & 2 on the extension as detailed in 5.3;
- remove the abutting Terminators from both the existing and extension cable;
- connect the extension cable to the existing cable using a Barrel Connector;
- ensure the terminator at the distant end of the new section is insulated;
- if the original terminator had an Earth Clip connection, then it is imperative that it too is reinstated. It is permissible to connect this to the newly installed barrel connector before insulating it. Running additional earth cable is not required;
- install MAUs in the new Trunk Cable section, in accordance with 4.8, to enable the connection of the new/relocated DTE;
- show the additional cable routes on the floor plan and update the schematic layouts.

The now extended segment of Trunk Cable shall not exceed the permitted maximum length as defined in 2.2 of this Technical Report. Where longer lengths are required a Repeater Unit must be used.

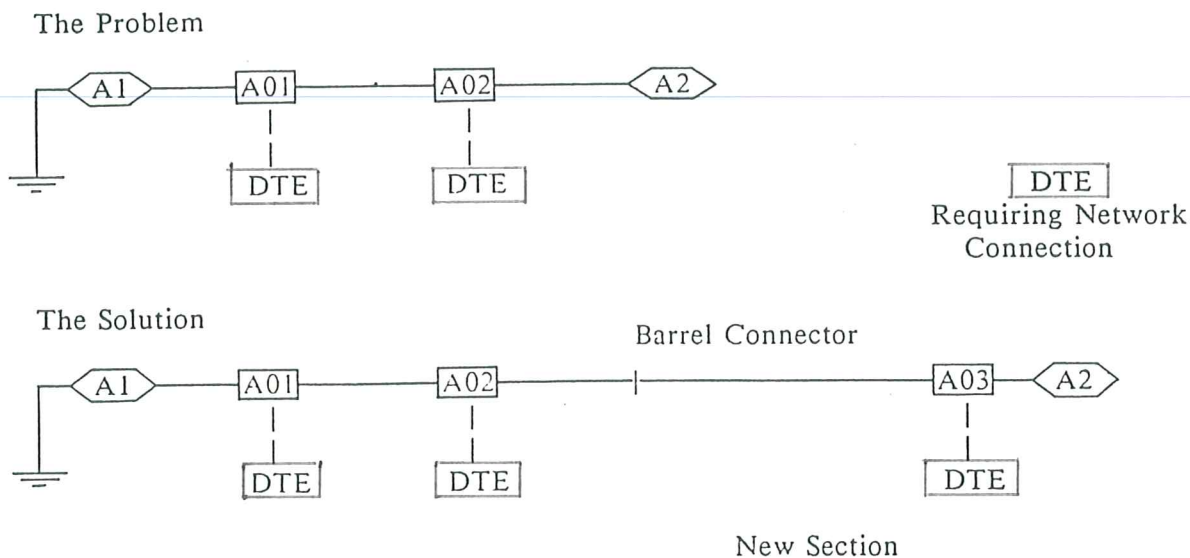

Figure 27 - Extension to One End of a Segment.

### 6.2.2 Add A New Segment

This is achieved by the provision of additional cable, MAUs, AUI cables and a repeater as follows:

- insert a MAU into the existing Trunk Cable at the nearest available point to where the new segment is required;
- choose a location to suit a repeater unit installation, remembering that it will require mains power and must be within AUI cable range (e.g. less than 50 m route distance) of both old and new cable segments;
- install the repeater;
- install and test the new Trunk Cable Segment as described in Clauses 4 and 5 of this Technical Report;
- insert a MAU in the new segment, at a point nearest the MAU installed in the existing system;
- using AUI Cables, connect the two MAUs to the Repeater Unit, thus linking the existing System and the new segment;
- install MAUs in the new Trunk Cable segment to connect to the new/relocated DTE.

Update the Floor Plan and schematic layouts, noting the Repeater Unit, the locations of the terminated ends of the Trunk Cable segment and the additional DTE.



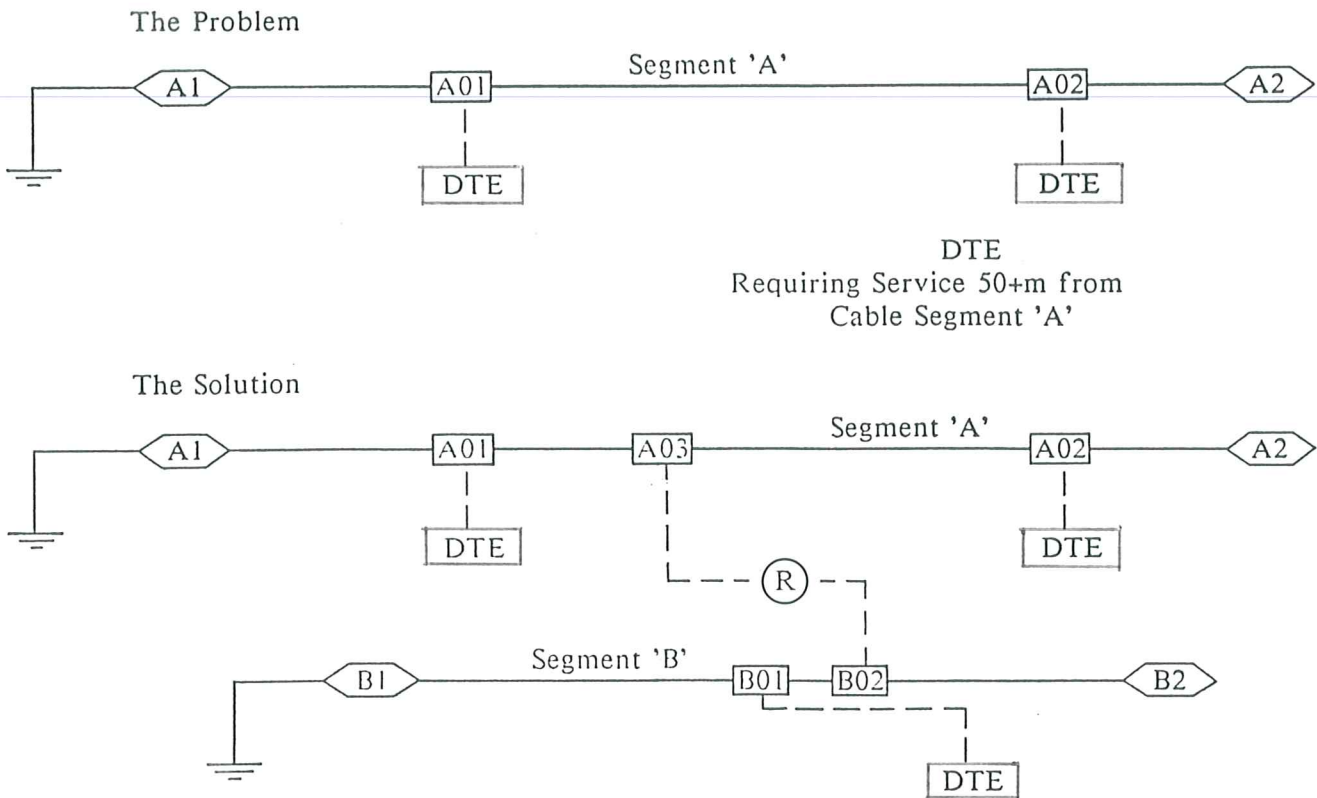

Figure 28 - Add a New Segment

### 6.2.3 Insert A Section Of Trunk Cable

If it is not possible to reach a DTE with an AUI cable, it is possible to add more trunk cable in the middle of an existing run. Again, it is essential for 10BASE5 cable installations that the additional cable comes from the same batch as the original installation. If this is not possible then a repeater will have to be used as detailed in 6.2.2 above.

If, however, the correct cable is available or if it is a 10BASE2 cable installation then the extension to the cable network is achieved as follows:

#### NOTE 7

*As this process involves severing the trunk cables one should only carry out this procedure with the permission of the Network Manager.*

- install the Trunk Cable extension in the new area and fit connectors and terminators on both ends in accordance with 4.4 of this Technical Report;
- test the new segment as described in 5.3;
- install MAUs in the new Trunk Cable segment to connect to the new/relocated DTE;
- remove the terminators from the new segment;
- cut the existing Trunk Cable at the point nearest to where the extension is required;
- install the correct connectors on both of the severed ends;
- attach the extension to the existing Trunk Cable, at the point where the cut was made using Barrel Connectors;

- insulate all connectors.

Mark the change on the floor and schematic plans, noting the position and identities of the Barrel Connectors and the additional DTE.

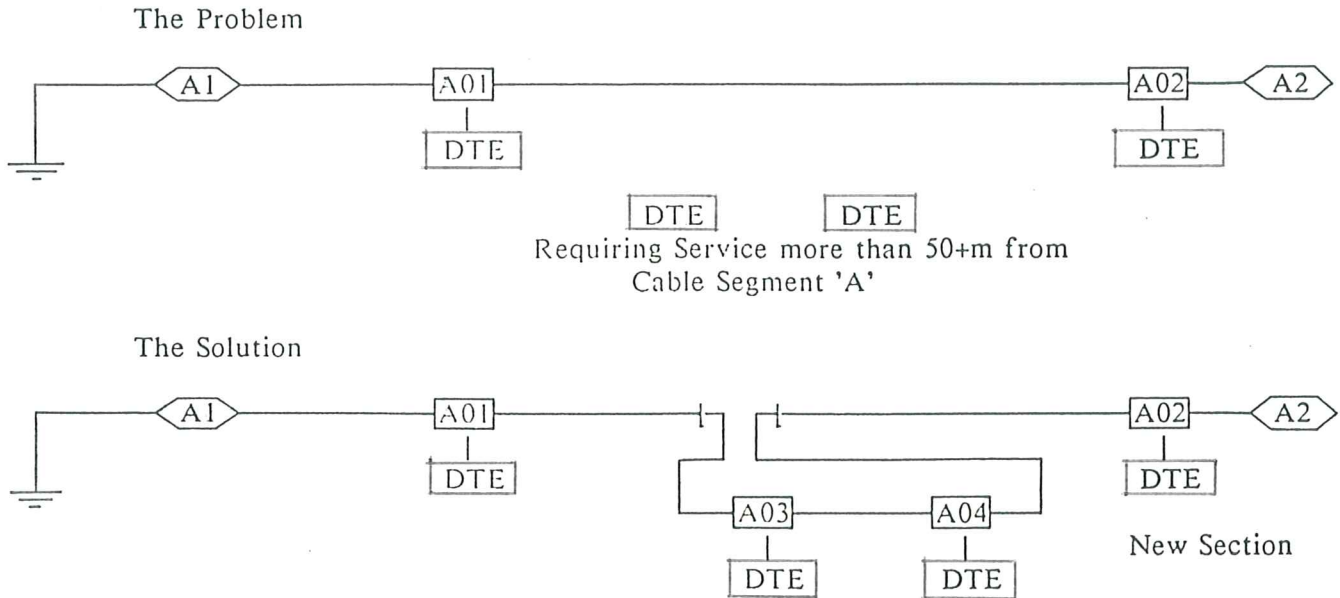

Figure 29 - Insert a Section of Trunk Cable

### 6.3 Relocation Of An Existing MAU

The following procedure should be carried out when recovering or re-locating a MAU on an existing network:

- turn off the served DTE device, thus de-powering the MAU;
- disconnect the AUI cable (if fitted) from both the DTE and MAU. If it is required or is feasible, recover the AUI cable, else leave it in situ;
- detach the MAU from the Tap Block or 'T'-piece to which it is attached by reversing the procedure in 4.8;
- if a piercing type Tap Block has been used, (see Figure 10) either, replace the previously saved dust cover, or recover it completely by reversing the installation procedure in 4.7. Re-seal the hole and cover it with black plastic tape;
- if the network comprises 10BASE2 trunk cable and provided the unavoidable break in service can be tolerated, then it is good practice for unused or "freed" 'T'-pieces or Tap connectors to be removed from the cable and replaced with female-female barrels. If this action is not possible it is quite in order to leave the third (male) connector(s) 'in line' and unterminated, provided it is insulated with BNC Connector Shroud, and its location recorded. Do not carry out the recovery of 'T'-pieces or BNC Taps without first obtaining the express permission of the customers' Network Manager;
- move DTE, MAU, AUI cable, Tap block/'T'-piece as necessary to the new location and install them again in the normal way.

## APPENDIX A

### GLOSSARY OF TERMS

<b>10BASE2</b>	10 MBits/s CSMA/CD Access Method Baseband Network. Maximum single segment length = 185 m (600 ft)
<b>10BASE5</b>	10 MBits/s CSMA/CD Access Method Baseband Network. Maximum single segment length = 500 m (1640 ft)
<b>ANSI</b>	American National Standards Institute, the sponsoring body for the IEEE Standards.
<b>AUI</b>	Attachment Unit Interface.
<b>AUI Cable</b>	A multi pair cable of specific design to connect an MAU to an AUI. (See also AUI Cable)
<b>Bridge</b>	A device for connecting together ISO 8802-3 LAN segments which cannot be joined by repeaters. This may be because of distance or the limitation of the ISO 8802-3 design parameters. Bridges are more 'intelligent' devices than repeaters in that they 'filter' out bad packets/collisions and local traffic thus preventing the remote network from receiving unnecessary transmissions. Additionally they check for the packet's conformance to a given protocol. This means that if there is more than one network operating on the same cable, but using different protocols, then some the packets of one protocol may be transmitted normally but others may not. (See also MAC Level Bridges)
<b>Coaxial Cable</b>	A two-conductor (centre conductor and shield), concentric, constant-impedance transmission line.
<b>Coaxial Connector</b>	The type of connectors attached to each end of a coaxial cable section.
<b>Cable Section</b>	A continuous length of coaxial cable, fitted with connectors at each end.
<b>Cable Segment</b>	A length of coaxial cable made up from one or more cable sections and connectors, electrically terminated at each end with its characteristic impedance (50 ohms).
<b>CSMA/CD</b>	Carrier Sense, Multiple Access with Collision Detection, the LAN protocol used on an ISO 8803-3 LAN.
<b>D-Type</b>	A multi-core cable type plug/socket connector with a 'D' cross section.
<b>Data Packet</b>	See Packet.
<b>Destination Address</b>	Part of a MAC frame specifying the destination of the data packet. This field may be 16 or 48 bits long. The address may specify an individual destination or a group address. Group addresses may be either a Multicast-Group address for a predefined group of destinations or a Broadcast Address denoting all destinations of the LAN.
<b>Data Terminal Equipment</b>	DTE. The source and destination for all communications on the network. Usually that equipment attached to a LAN port.

<b>DMFM</b>	Digital Multifunction Meter
<b>Ethernet</b>	A specification for a LAN system using a CSMA/CD protocol. Ethernet was first proposed by Xerox, Intel and DEC in the USA as a Universal Standard for LANs. Since then the protocol has been developed by IEEE 802 and progressed to an International Standard. Ethernet is still used by many manufacturers in their LAN products.
<b>Frame Check Sequence</b>	Frame Check Sequence:- part of a MAC frame. This is a 32 bit cyclic redundancy check (CRC) used to validate the data being transmitted. When a data packet is transmitted a CRC check is made on the data and the result sent as part of the packet. At the receiving end of the virtual circuit the same CRC check is performed and the result checked against the CRC sent. This is a fairly rigorous check and practically ensures the detection of any transmission errors.
<b>IEEE</b>	The Institute of Electrical and Electronics Engineers Inc.
<b>IEEE 802.3</b>	Properly known as ANSI/IEEE Std 802.3-1985, this is a standard for a LAN protocol using Carrier Sense, Multiple Access with Collision Detection (CSMA/CD). This is the 'official' version of the original Ethernet standard.
<b>ISO</b>	International Organization for Standardization. ISO is a Greek word meaning 'equal' eg isobars, isotherms, isometric etc.
<b>ISO 8802-3</b>	The ISO equivalent of ANSI/IEEE Std 802.3-1988.
<b>Local Area Network (LAN)</b>	A data network optimised for a moderate size geographic area such as a single office building, a warehouse, or a campus. Generally comprises of a single communications channel of moderate to high data rate, low delay and low error rate, offering multi-user access.
<b>LLC</b>	Logical Link Control.
<b>LLC Data</b>	Part of a MAC frame. This is the actual data being transmitted.
<b>MAC</b>	Media Access Control.
<b>MAC Level Bridges</b>	Sometimes referred to as Data Link Bridges, these form a general purpose link between any two networks, passing LAN data at network speeds, regardless of the high-level protocol being used. Data Link Bridges are 'vendor independent' thus able to support both Industry Standard and Proprietary protocols.
<b>MAC Frame</b>	A data packet consisting of the Preamble, SFD, Destination address, Source address, length, LLC data unit, Pad and Frame Check sequence fields.
<b>MAU Media Access Unit</b>	An electronic unit which is physically attached to both the Trunk Cable segment and the AUI cable. The MAU monitors the activity on the trunk cable, and when appropriate, will transmit and receive data on behalf of the Station to which it is attached.
<b>Network Components</b>	The hardware elements that make up the transmission system of the network (i.e. cables, MAUs, repeaters, connectors).
<b>Network Delay</b>	The time delay incurred by signals passing between DTE located at opposite extreme ends of the network. Made up from the cumulative delays introduced by each cable and every component in the transmis-

sion path, it is measured in Bits. For the correct operation of the CSMA/CD Access Method, the total Network Delay must be less than 511 Bits times.

**N-Type**

The type of coaxial connector permitted to join sections of Thick LAN co-axial cable.

**OSI**

Open Systems Interconnection. A set of standards intended to allow the interconnection of equipment and software from different manufacturers. The model is depicted in seven 'levels' or 'layers' and it is the functionality and interfaces between the layers that are defined in the OSI Standards.

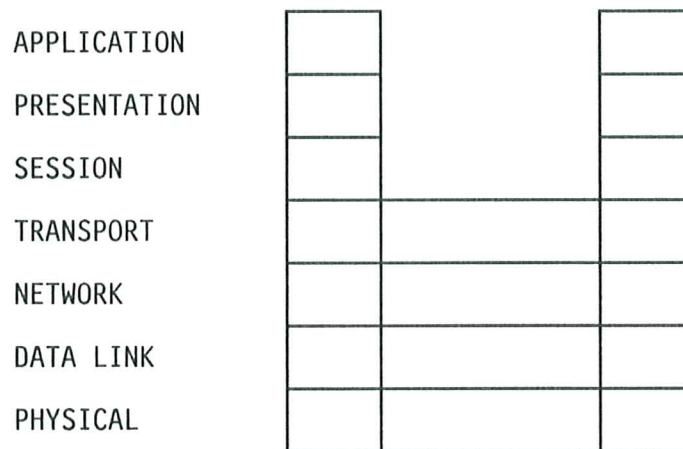

**Packet**

This is the method used to transmit data over the ISO 8802-3 LAN. Data is packetised in a set format conforming to the LAN protocol in force. The format used is:

Preamble	7 octets
SFD	1 octet
Destination Address	2 or 6 octets
Source Address	2 or 6 octets
Length	2 octets
LLC Data	
Pad	
FCS	4 octets

**PAD**

Part of a MAC frame. This is dummy data to fill a partly filled frame which would otherwise be under size.

<b>Preamble</b>	A bit pattern of 7 octets of 10101010 for synchronisation. This is designed to allow all the MAUs on the network to synchronise to the data signal. Although the data packet is transmitted synchronously there is no network clock to keep all the devices in step, therefore it is necessary to resynchronise for every packet. This is cheaper to implement and makes the design of the network and equipment easier.
<b>Propagation velocity</b>	The speed at which a signal travels down a cable. It depends on the dielectric material used for cable insulation and the geometry of the cable cross-section.
<b>Repeater Unit</b>	An electronic device used to extend the length and topology of the network beyond that imposed by a single segment, up to the allowable end-end trunk transmission line length. A Repeater Unit performs the basic functions of restoring the signal amplitude and timing. Additionally it can automatically isolate faulty segments and reconnect after the fault has been cleared (see also Bridge). MAUs serving Repeater Units must not have SQE enabled.
<b>SFD</b>	Start of Frame Delimiter
<b>Source Address</b>	Part of a MAC frame specifying the source of the data packet. This field may be 16 or 48 bits long.
<b>SQE</b>	Signal Quality Error. A mechanism by which a MAU informs its DTE that a collision has been detected, irrespective of whether that DTE is transmitting or not. This is achieved by monitoring the medium, and informing the DTE that more than one DTE is transmitting. MAUs serving Repeater Units must not have SQE enabled.
<b>Station</b>	A single addressable unit on the LAN.
<b>Tap</b>	The physical device that connects the MAU to the LAN coaxial cable. There are several methods in use. Some require a break to be made in the cable and the end joined with a 'T' section thus enabling an MAU to be attached to the third port. The use of this type requires the entire network segment at least to be taken out of service while the attachment is made. Other taps can be placed onto the cable while the network is operating without disturbing existing users.
<b>Terminators</b>	A special connector fitted to the ends of cable segments. These connectors contain an impedance between their inner and outer conductors. The value of the impedance matches the characteristic impedance of the cable used.
<b>AUI Cable</b>	The AUI cable is a multicore cable, containing four screened pairs within an all embracing screen, and is terminated with one male and one female 15 Way "D-Type" connectors. Used to join a Station to a Media Access Unit (MAU). Also known as an AUI cable (Access Unit Interface).
<b>MAU</b>	An electronic unit which is physically attached to both the Trunk Cable segment and the AUI cable. The MAU monitors the activity on the trunk cable, and when appropriate, will transmit and receive data on behalf of the Station to which it is attached. MAUs serving Repeater Units must not have SQE enabled.

**TDR**

Time Domain Reflectometry

**Trunk Cable**

The coaxial cable chosen to form a segment (Thick or Thin).

---





## APPENDIX B

### DIAGRAMS, PLANS AND LABELLING DETAILS

This Appendix has been compiled to aid planners and installers with the preparation and interpretation of the following documentation:

- floor plans;
- schematic diagrams;
- cable labelling;
- equipment labelling.

The following pages show examples of simple network schematics of one or more segments, a fibre optic link. Included also is part of a fictitious installation in "Net House" which shows;

- the overall installation in schematic representation;
- detailed information on segment 'A' of the installation;
- floor plans showing the physical layout of segment 'A'.

It has not been thought necessary to produce any detail of floors 1 to 10 for this example.

MAUs serving repeaters may be connected at any 2,5 m marker point on the Trunk Cable, they are not restricted to the ends of Trunk Cables only.

Labelling details are included in this appendix.

#### Typical Networks Showing Repeater Usage

(Remember, Repeaters require access to an A.C. mains supply)

#### A SINGLE SEGMENT NETWORK



A NETWORK OF FOUR 500 METRE SEGMENTS OF TRUNK CABLE



A NETWORK USING FIBRE OPTIC REPEATERS

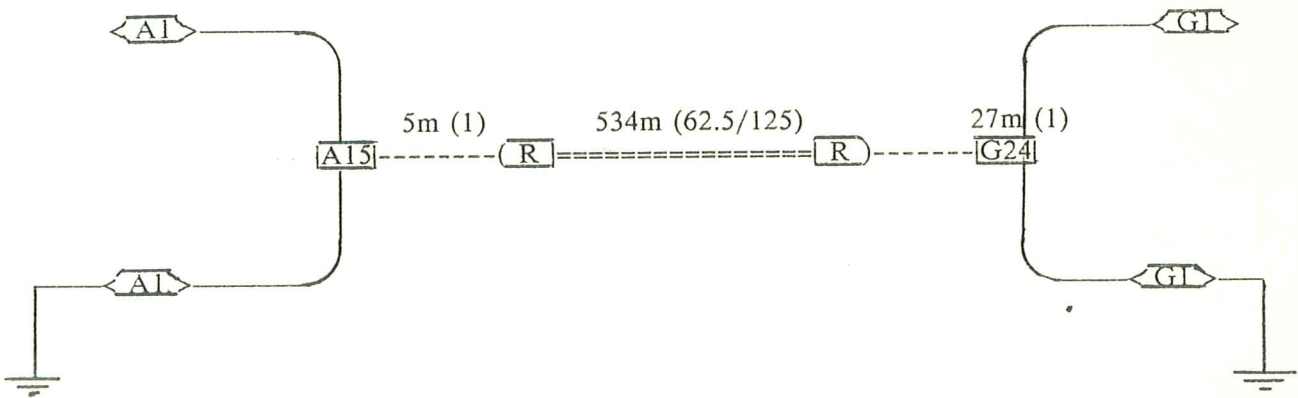

### A NETWORK OF SIX TRUNK CABLE SEGMENTS

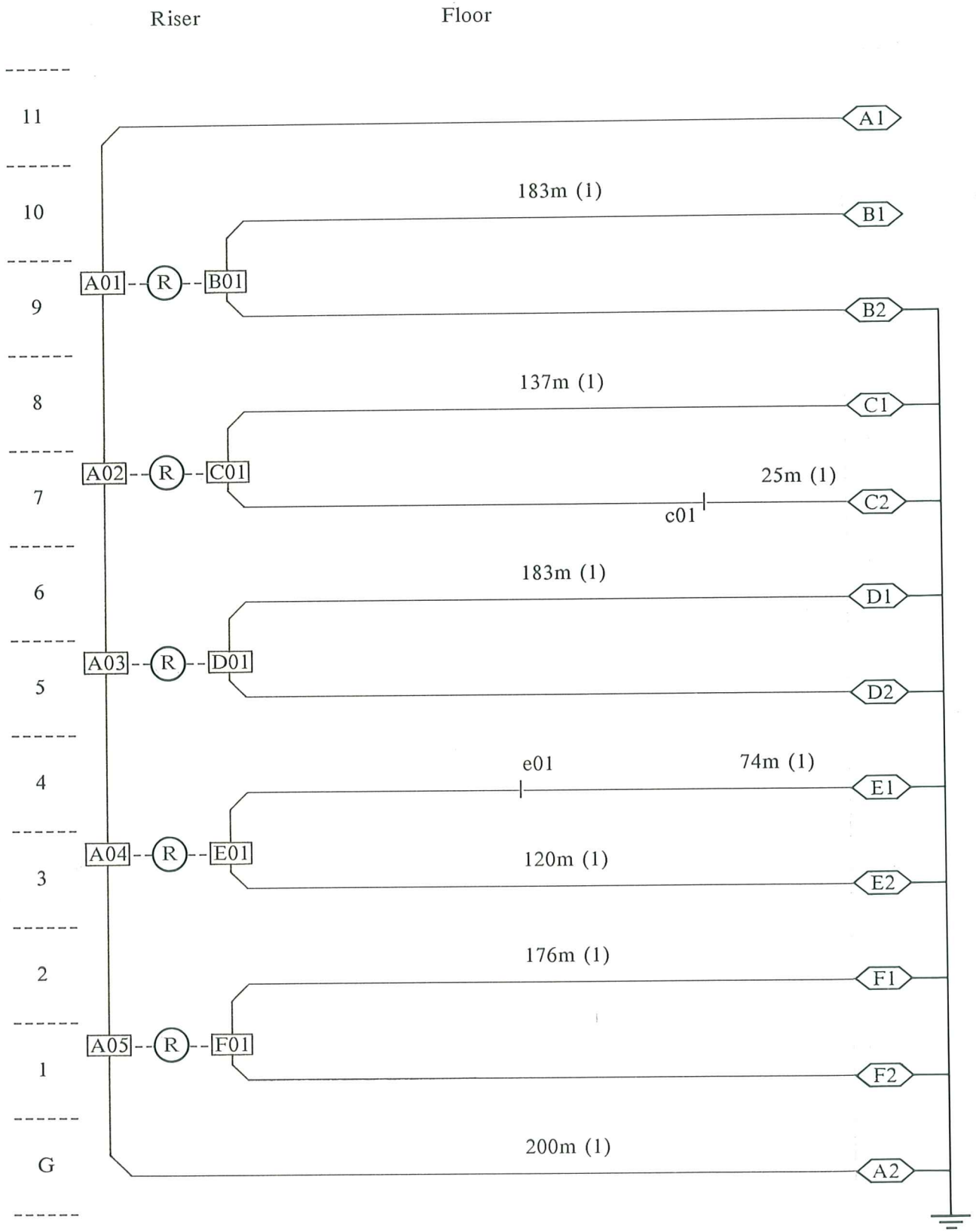

DETAIL OF CABLE SEGMENT "A"

NB ALL CABLE = 10BASE5 TRUNK

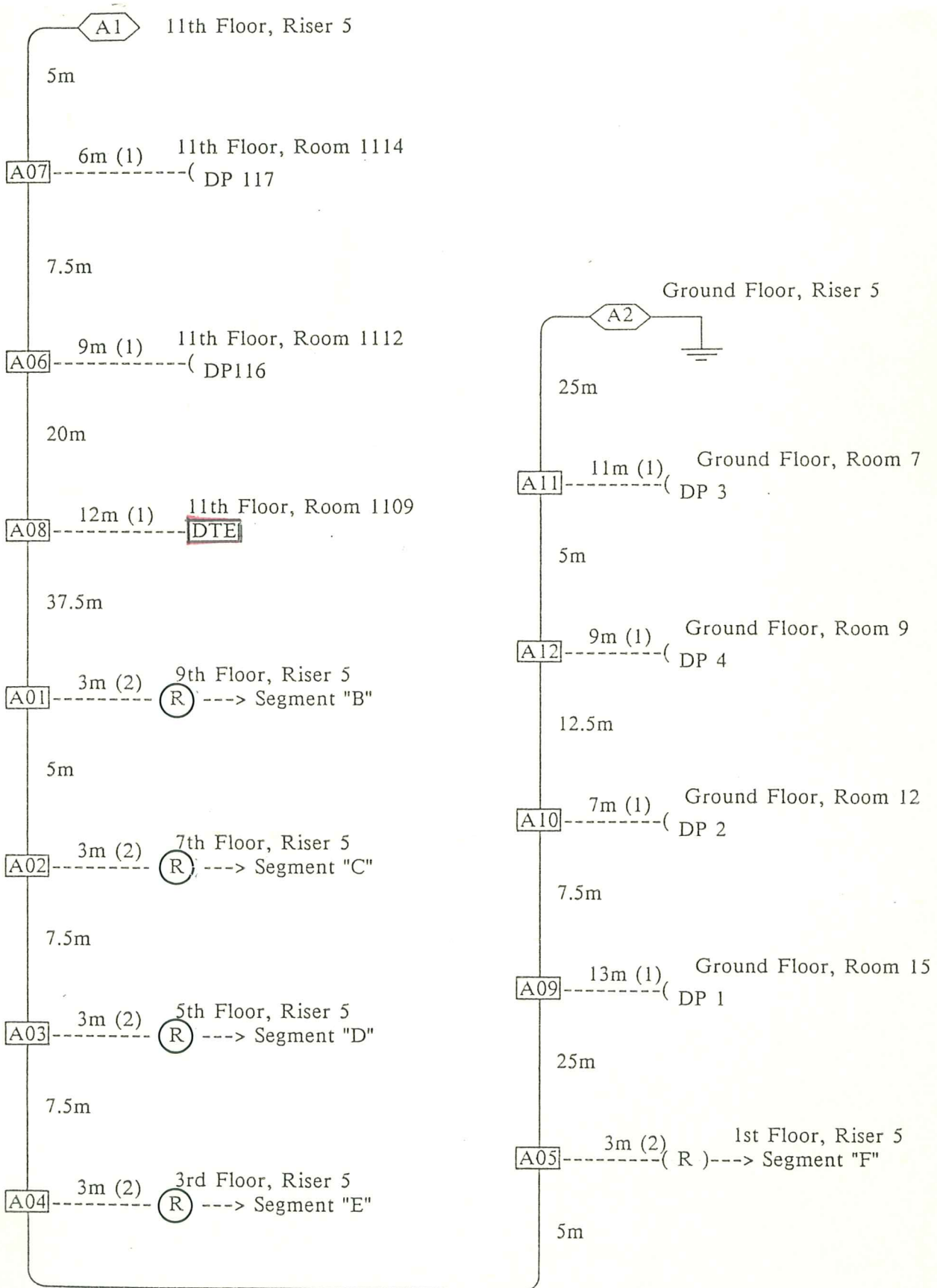

INSTALLATION GROUND FLOOR NET HOUSE

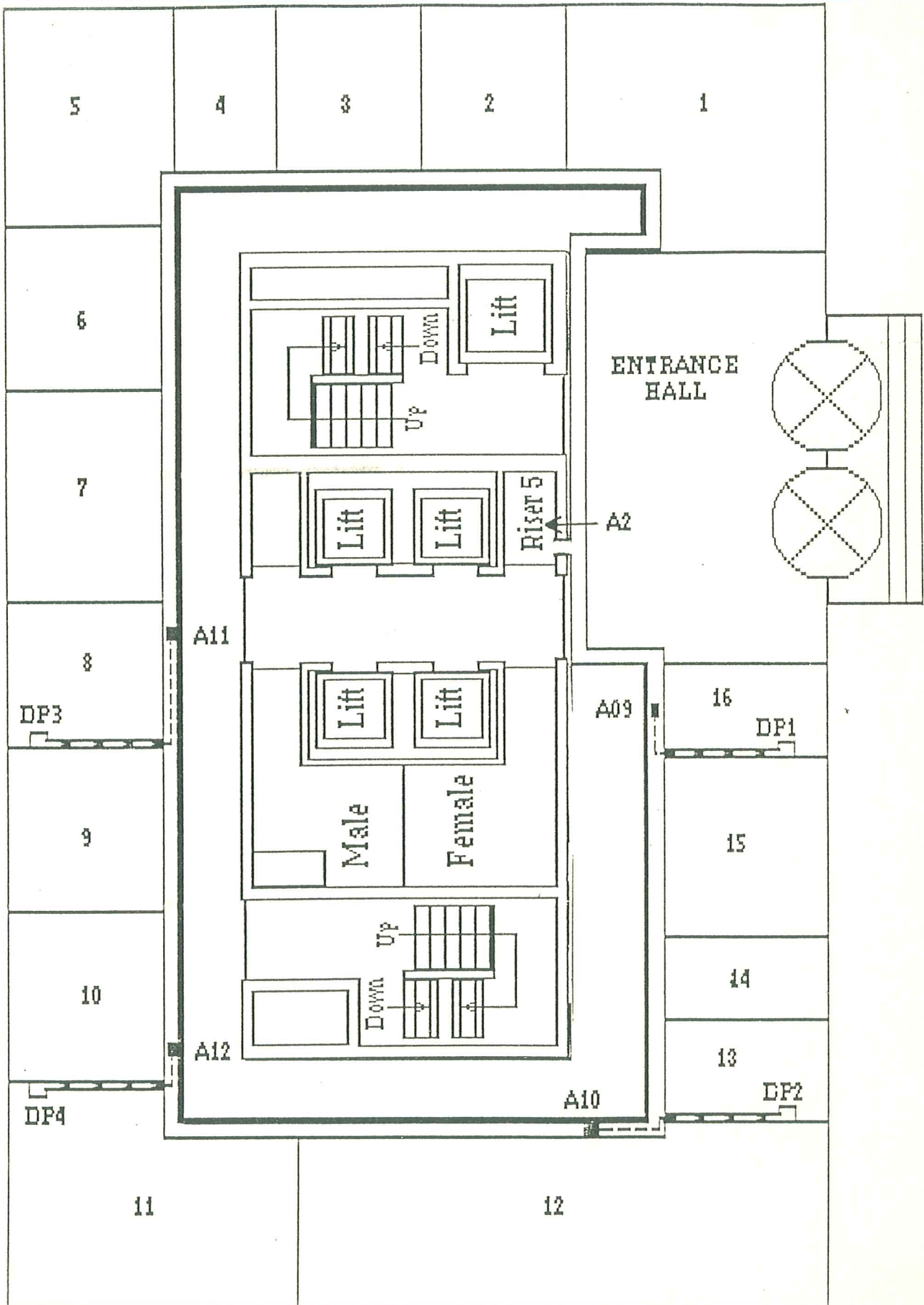

INSTALLATION 11th FLOOR NET HOUSE

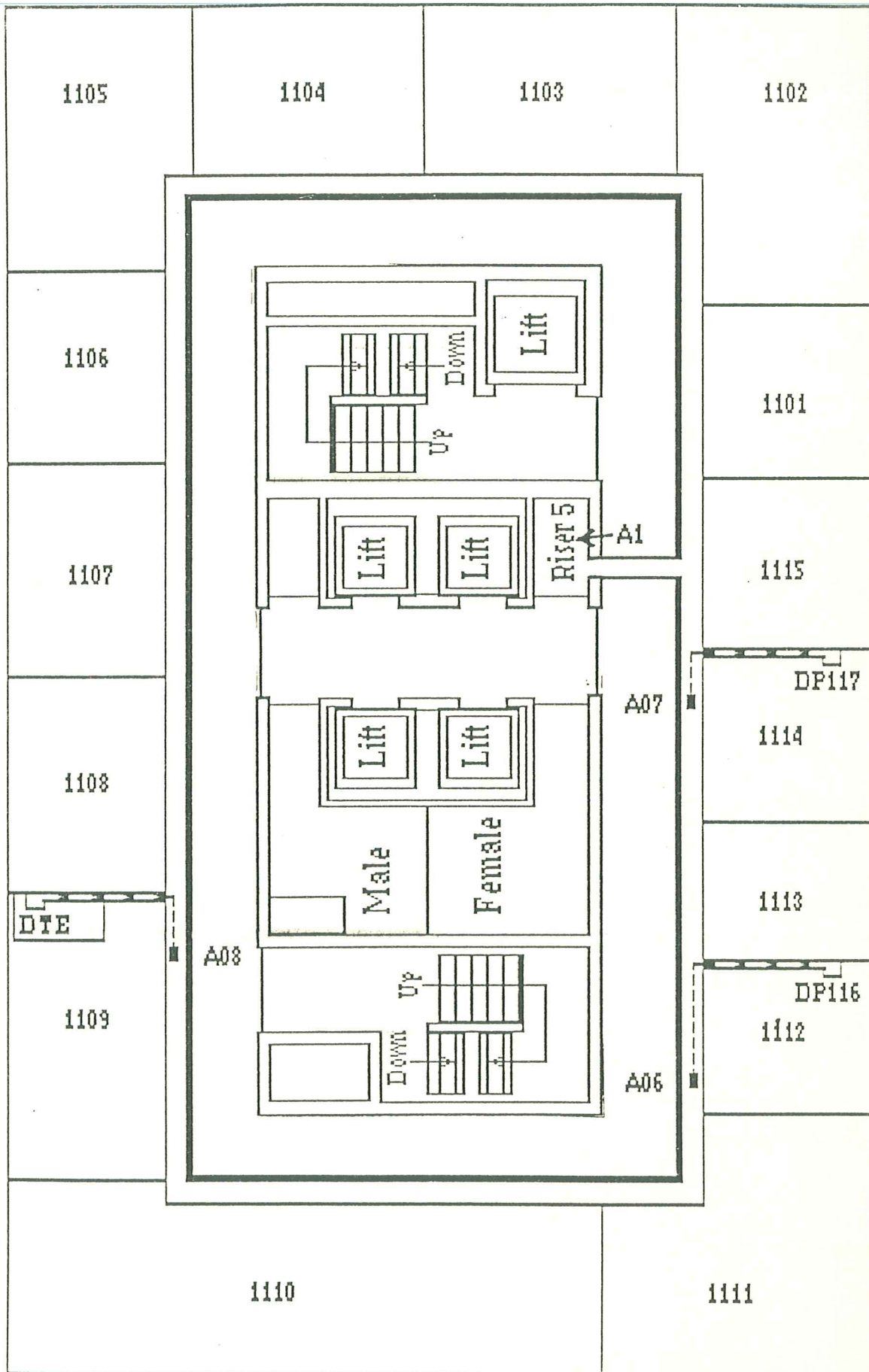

DATA PORT LABELS

PLAIN

From	AUI type
length	<input type="checkbox"/>
Port	1 or 2
length	<input type="checkbox"/>
DTE	
Extra AUI max for :	
type 1	type 2

From	AUI type
length	<input checked="" type="checkbox"/>
Port	1 or 2
length	<input type="checkbox"/>
DTE	
Extra AUI max for :	
type 1	type 2
30	3

From	AUI type
length	<input checked="" type="checkbox"/>
Port	1 or 2
length	<input type="checkbox"/>
DTE	
Extra AUI max for :	
type 1	type 2
40	6

EXAMPLES

LABELLING OF FAN-OUT UNITS & CABLES

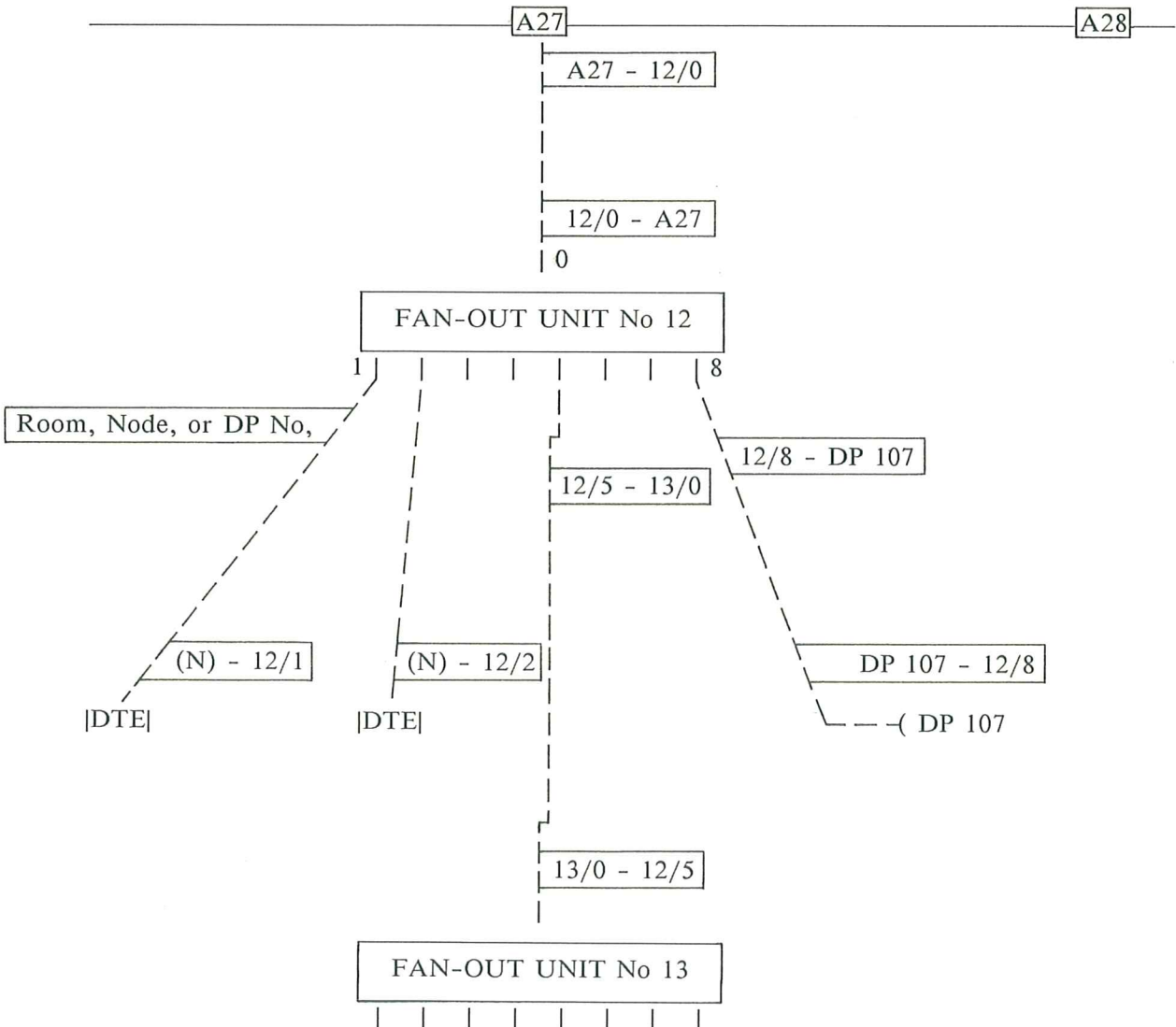





## APPENDIX C

### INSTALLED CABLE ACCEPTANCE TESTS AND EQUIPMENT

#### Checking the Trunk Cable Before MAU Installation

Access is needed to both ends of the Trunk Cable to check insulation and loop resistance. The remote end of the cable and all user accessible points must have a 'high voltage warning' notice during megger tests.

#### Insulation Resistances

**WARNING:** Under no circumstances connect a megger to the centre conductor of the Trunk Cable as the high voltage will destroy all attached MAUs.

Remove the earth wire from the Trunk Cable. The insulation resistance of the screen to mains earth shall not be less than 200 M $\Omega$  when measured with a megger at 500 V.

#### Loop Resistance

**WARNING:** If MAUs are attached, the voltage applied between the centre conductor of the Trunk Cable and screen shall not exceed  $\pm 2$  V.

Access is required to both ends of the Trunk Cable. At one end, the inner and all screens should be connected together.

The loop resistance of a 10BASE5 coaxial cable segment with MAUs attached when measured at 20 °C, shall not exceed 10 M $\Omega$ /m.

The loop resistance of a 10BASE2 segment should not exceed 10 ohm total for the segment. Each in-line connector pair or MAU should contribute no more than 10 M $\Omega$ .

#### Time Domain Reflectometer Tests

##### Time Domain Reflectometer Description

The Time Domain Reflectometer sends step voltage pulses down the cable under test.

Cable faults are points of discontinuity, and cause reflection down the cable to the source where they are detected by the TDR.

The reflected voltage is superimposed on the advancing initial step, and is displayed on the TDR as a step-up or a step-down transition.

Step-up transitions are caused by inductive, or resistive faults, which have a higher resistance than the resistive component of the characteristic impedance of the Trunk Cable. (e.g. open cct)

Step-down transition results from capacitive faults, or faults of lower resistance than normal resistive component of the characteristic impedance of the Trunk Cable. (e.g. short cct)

The time delay between incident and reflected pulses gives the distance of the fault from the TDR. The TDR automatically converts this time interval to a distance (in metres).

##### *NOTE C.1:*

*MAUs shall not transmit onto the Trunk Cable during the TDR testing. If this occurs the TDR input could be destroyed.*

#### TDR Resolution and Accuracy

It is important to distinguish between resolution and accuracy as applied to a TDR.

RESOLUTION means the minimum separation of two independent cable faults which the TDR can detect. The primary factor determining this, is the rise time of the pulses received by the TDR. Since the rise time of any pulse is degraded by its transmission through a long cable, the resolution will be dependent upon both the TDR and the length of cable under test.

ACCURACY is the measure of how close the TDR distance reading is to the actual distance of the discontinuity from the TDR.

The TDR measures the electrical 'length' from the instrument to the cable fault. To relate electrical 'length' to actual physical length, take into account the following factors:

- cable snaking, twist and loops;
- Propagation velocity variation in a given type of cable;
- varying propagation velocities, caused by Trunk Cable sections from different cable batches or manufacturers;
- accurate physical cable length measurement.

'Propagation velocity' is the speed at which a signal travels down a cable. it depends on the dielectric material used for cable insulation and the geometry of the cable cross-section.

The accuracy to which the propagation velocity is known and controlled will determine the relationship between the electrical and physical lengths.

Most cable manufacturers can control propagation velocity to within 0,5%. The same cable from different manufacturers may have a variation of 2-3%. It is thus desirable not to mix cable from different manufacturers, in the same segment. ISO 8802-3 calls for 10BASE5 trunk cable with a minimum velocity of propagation of 0,77 c to be used.

For 10BASE2 trunk cable, the value to be used is 0,65 c (c = 300 000 km/s).

### **Improving Distance Accuracy**

The Trunk Cable causes degeneration of the TDR waveform and thus the accuracy reduces with distance.

The shorter the length of Trunk Cable between the TDR, and the point under test the more accurate will be the results.

For example, with a 10BASE5 segment the longest passive cable run will be 500 m. If the cable cannot be broken for test purposes, the worst case situation will be a point of discontinuity at a distance of 250 m from one end (ie the centre of the run). This point is identifiable to within 10 m.

There are two ways to improve the accuracy of distance measurements:

- take multiple readings;
- since all TDR distance errors are percentage errors of the 'scan length', a good technique is to progressively reduce the distance to the fault giving a more accurate result;
- use all available information;
- use a known point on the cable to calibrate the TDR;
- accuracy is improved if the Trunk Cable dielectric is the same for the entire length of the cable;
- for example, if the cable propagation velocity changes at 300 m, calibrate the TDR for the dielectric of the first section and then scan for 300 m only.

### **Common Mechanical Faults**

During installation, the Trunk Cable may suffer mechanical damage that results in either open circuit or full short circuit.

Intermediate faults may occur due to:

- severe abrasion resulting in part of the sheath, screen and dielectric being worn away;
- accidental cable crimping, resulting in a rupture to the dielectric.

### Emission Levels

The installed Baseband Cables shall comply with local codes with regard to Emission Levels.

### TDR Displays

The waveforms following show examples of various TDR displays.

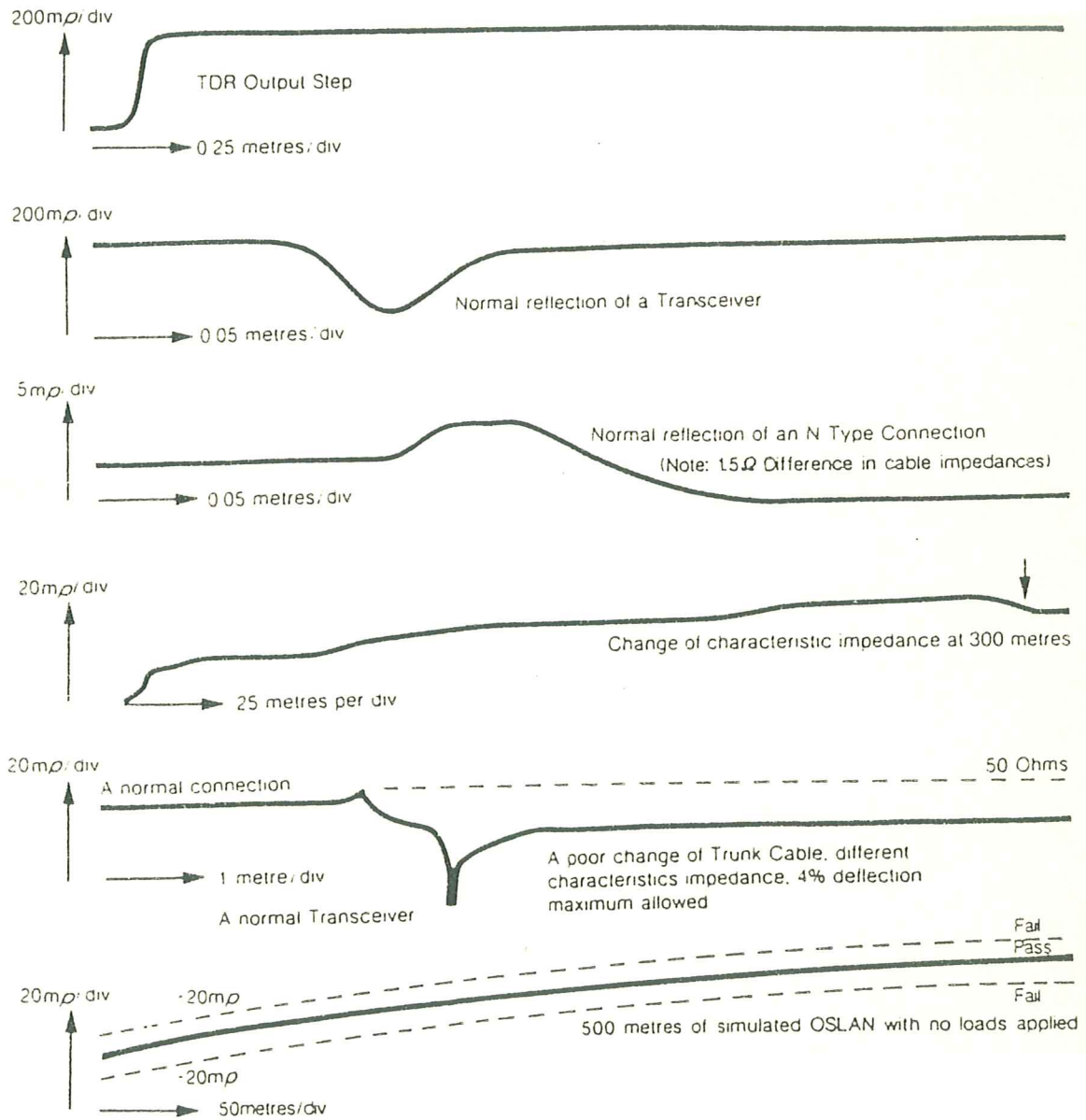

NOTE C.2:

mp = milli Rho (1 milli Rho reflection is 0,1% of the initial TDR Voltage Step).

*Maximum reflection allowed at any point is 7% of the incident wave when driven by a Transceiver.  
Maximum reflection from any feature to be no more than 4% of the incident wave when driven by a  
Transceiver.*

---

Features on the TDR Maps of each Trunk Cable Section should be identified and made available, with the Floor Plan to the Maintenance Engineer.

APPENDIX D

COMPONENT CHECK LIST

CODE	TITLE	QTY
	CABLE AUI	
	AUI CABLE ASSEMBLY length W	
	AUI CABLE ASSEMBLY length X	
	AUI CABLE ASSEMBLY length Y	
	AUI CABLE ASSEMBLY length Z	
	CABLE COAXIAL 10BASE5 TRUNK	
	CABLE COAXIAL 10BASE2 TRUNK	
	CONNECTOR BNC PLUG	
	CONNECTOR BNC BARREL	
	CONNECTOR BNC T-PIECE	
	CONNECTOR BNC TERMINATION	
	CONNECTOR BNC SHROUD	
	CONNECTOR N-TYPE PLUG	
	CONNECTOR N-TYPE BARREL	
	CONNECTOR N-TYPE TERMINATION	
	AUI CONNECTOR KIT (MALE)	
	AUI CONNECTOR KIT (FEMALE)	
	DATA PORT	
	LOCAL REPEATER	
	REMOTE REPEATER	
	FIBRE OPTIC REPEATER	
	BNC MAU TAP	
	Piercing TAP	

CODE	TITLE	QTY
	PIERCING TAP TOOLKIT	
	MAUs WITHOUT TAPS	
	MAUs + BNC TAPS	
	MAUs + Piercing TAPS	
	MAUs + N-TYPE TAPS	
	TRANSCEIVER MULTIPLEXOR	

