

ECMA

Standardizing Information and Communication Systems

**H.323 / B-ISDN Signalling
Interoperability**

ECMA

Standardizing Information and Communication Systems

**H.323 / B-ISDN Signalling
Interoperability**

Brief History

This Technical Report provides information relating to Broadband Integrated Services Digital Networks (including Broadband Private Integrated Services Networks) and the ways in which they can interoperate with IP-based packet networks employing ITU-T recommendation H.323 in support of multimedia communications.

The Technical Report is based upon the practical experience of ECMA member companies and the results of their active and continuous participation in the work of ISO, ITU-T, ETSI and other international and national standardization bodies. It represents a pragmatic and widely based consensus.

This Technical Report was written in cooperation with ETSI and is also published as an ETSI Guide.

Table of contents

1	Scope	1
2	References	1
3	Acronyms	2
4	Introduction	3
4.1	Overview of H.323 and related recommendations	3
4.1.1	H.323 concept and entities	3
4.1.2	Channels defined in H.323	4
4.1.3	Protocols and related standards	4
4.1.4	Call procedures	5
4.1.5	Fast connect	6
4.1.6	Inter-domain signalling	6
4.2	Overview of modelling work relating to B-ISDN signalling	6
4.3	Overview of B-ISDN signalling - combined call/bearer control	8
4.4	Overview of B-ISDN signalling - separated call and bearer control	8
5	Related work	9
5.1	ECMA TC32-TG15 and ETSI SPS5 WG5	9
5.2	ITU-T Study Group 16	9
5.3	ETSI project TIPHON	10
5.3.1	General	10
5.3.2	Gateway functional decomposition	12
5.4	ATM Forum SAA/RMOA	12
5.5	ECMA TC32-TG13	12
5.6	IETF	13
5.6.1	SIP	13
5.6.2	IPTEL	13
5.6.3	E.164 Birds of a Feather activity	13
5.6.4	NAVDEC	13
6	H.323 and modelling of B-ISDN signalling	13
7	H.323 interworking via a gateway with B-ISDN separated call and bearer control	13
7.1	Scenarios	14
7.2	Protocol interworking architecture	16
7.2.1	Scenario 1	16
7.2.2	Scenario 2	18
7.2.3	Scenario 3	20
7.3	Session control in B-ISDN environment	20
7.4	Resource control in B-ISDN environment	21
7.5	Call establishment	21
7.6	Bearer establishment	21
7.7	Addressing	22

7.7.1	Addressing in H.323	22
7.7.2	Addressing in B-ISDN and B-PISN	23
7.7.3	Address interworking between H.323 and B-ISDN	24
7.8	Message sequences for basic communication establishment	24
7.8.1	Scenarios 1a and 1b	24
7.8.2	Scenario 1c	26
7.8.3	Scenarios 2a and 2b	27
7.8.4	Scenario 2c	29
7.8.5	Scenario 3c	31
7.9	Generic Functional Protocol	32
7.10	Supplementary services	32
7.10.1	Introduction	32
7.10.2	Supplementary services in scenario 1	33
7.10.3	Supplementary services in scenario 2	33
7.10.4	Supplementary services in scenario 3	33
7.10.5	Areas for further work	34
7.11	Conferencing	34
7.12	Impact of T.120	34
8	H.323 interworking via a gateway with B-ISDN combined call/bearer control	34
8.1	Scenarios	34
8.2	Protocol interworking architecture	36
8.2.1	Scenario 1	36
8.2.2	Scenario 2	37
8.2.3	Scenario 3	38
8.3	Session control in B-ISDN environment	39
8.4	Resource control in B-ISDN environment	39
8.5	Call/bearer establishment	39
8.6	Addressing	39
8.7	Message sequences for basic communication establishment	39
8.7.1	Scenarios 1a and 1b	40
8.7.2	Scenario 1c	42
8.7.3	Scenarios 2a and 2b	42
8.7.4	Scenario 2c	44
8.7.5	Scenario 3c	45
8.8	Generic functional protocol	45
8.9	Supplementary services	46
8.10	Conferencing	46
8.11	Impact of T.120	46
9	Summary of interworking scenarios in 7 and 8	46
9.1	Scenario 1	46
9.2	Scenario 2	46
9.3	Scenario 3	47
10	Application of B-ISDN separated protocols to gatekeeper-to-gatekeeper communication	47

11	Connection of remote H.323 environments via B-ISDN	47
11.1	Case 1 – full interworking	47
11.2	Case 2 - tunnelling	47
11.2.1	Scenario T1 - tunnelling of session and resource control protocols	48
11.2.2	Scenario T2 - tunnelling of session control protocol only	49
11.2.3	Scenario T3 - tunnelling of resource control protocol only	49
11.2.4	Additional considerations when endstations employ H.323 annex C (native IP network or IP over ATM network)	50
11.2.5	Conclusions on tunnelling scenarios	50
12	Co-existence of H.323 annex C and B-ISDN signalling in the same network	51
13	Impact of H.323 on future mobility protocols	51
13.1	Introduction	51
13.2	Mobility concepts	51
13.3	Mobility architecture	52
13.4	Virtual Home Environment (VHE)	53
14	Conclusions and recommendations	54

1 Scope

The purpose of this Technical Report is to investigate the interoperability of H.323 and B-ISDN signalling environments with a view to identifying possible standardization activities in this area. The following aspects of interoperability are investigated:

- the interworking of H.323 and B-ISDN environments, both separated and combined, via a gateway;
- the connection of remote H.323 environments via B-ISDN;
- the use of H.323 annex C (H.323 on ATM), including the co-existence of H.323 annex C and B-ISDN signalling in the same network and possible future enhancement of annex C;
- the application of the B-ISDN separated call control protocol to gatekeeper-to-gatekeeper communication;
- the impact of H.323 on future mobility protocols.

For each of the above, due consideration is given to the following: addressing impact (including use of IP addressing); conferencing models; T.120 data impact; basic call procedures; generic functional procedures (GFP) and supplementary services; end-to-end resource and session level protocols.

Possible future standardization activities resulting from this Technical Report will include H.323 work items as well as B-ISDN signalling work items.

2 References

- | | |
|--|--|
| ECMA-155 | Private Integrated Services Networks - Addressing (1997) |
| ECMA-254 | Broadband Private Integrated Services Network (B-PISN) - Inter-Exchange Signalling Protocol - Generic Functional Protocol (1996) |
| ISO/IEC 11571 | Information technology - Telecommunications and information exchange between systems - Numbering and sub-addressing in private integrated services networks (1994) |
| ISO/IEC 13247 | Information technology - Telecommunications and information exchange between systems - Broadband Private Integrated Services Network - Inter-exchange signalling protocol - Basic call/connection control (1997) |
| ATM Forum PNNI 1.0 | Private Network-Network Interface Specification Version 1.0 (af-pnni-0055.000) (1996) |
| ATM Forum UNI 4.0 | User-Network Interface (UNI) Signalling Specification Version 4.0 (af-sig-0061.000) (1996) |
| ETSI DTR/
TIPHON-04002 V1.1.6 | Telecommunications and Internet Protocol Harmonization Over Networks (TIPHON); Naming and Addressing; Scenario 2 (1998-08) |
| ETSI DTR/
TIPHON-00001 V1.1.2 | Telecommunications and Internet Protocol Harmonization Over Networks (TIPHON); Description of technical issues (1998-10) |
| ETSI DTS/
TIPHON-02002 V0.2.0 | Telecommunications and Internet Protocol Harmonization Over Networks (TIPHON); Network architecture and reference configurations; Phase II: Scenario 1 + Scenario 2 (1998-09) |
| ETSI TS 101 324 V1.1.6DTR/
TIPHON 04001 | Telecommunications and Internet Protocol Harmonization Over Networks (TIPHON); Naming and addressing; Scenario 1 (1998-06) |
| IETF RFC 1483 | Multiprotocol Encapsulation over ATM Adaptation Layer 5 (1993) |

IETF RFC 1577	Classical IP and ARP over ATM (1994)
ITU-T Rec. H.225.0	Call signalling protocols and media stream packetization for packet based multimedia communication systems (1998)
ITU-T Rec. H.245	Control protocol for multimedia communication (1998)
ITU-T Rec. H.323	Packet based multimedia communication systems (1998)
ITU-T Rec. H.450.1	Generic functional protocol for the support of supplementary services in H.323 (1998)
ITU-T Rec. H.450.2	Call transfer supplementary service for H.323 (1998)
ITU-T Rec. H.450.3	Call diversion supplementary service for H.323 (1998)
ITU-T Rec. Q.2726.1	B-ISDN user part - ATM end system address (1996)
ITU-T Rec. Q.2931	Broadband Integrated Services Digital Network (B-ISDN) - Digital Subscriber Signalling System No. 2 (DSS2) - User-Network Interface (UNI) Layer 3 specification for basic call/connection control (1995)
ITU-T Rec. Q.2932.1	Digital Subscriber Signalling System No. 2 - Generic functional protocol: Core functions (1996)
ITU-T Rec. Q.931	Digital Subscriber Signalling System No. 1 (DSS 1) - ISDN user-network interface layer 3 specification for basic call control (1998)
ITU-T Rec. T.120	Data protocols for multimedia conferencing (1996)
Draft ITU-T Rec. Q.298x-sbc	Broadband Integrated Services Digital Network (B-ISDN) - Digital Subscriber Signalling No. 2 (DSS2) - Point-point multiconnection call related bearer control protocol
Draft ITU-T Rec. Q.29cc-ROSE	Broadband Integrated Services Digital Network (B-ISDN) - Call control protocol
Draft ITU-T TRQ-2001	General aspects for the development of unified signalling requirements

3 Acronyms

AESA	ATM End System Address
AFI	Authority and Format Identifier
ATM	Asynchronous Transfer Mode
B-HLI	Broadband High Layer Information
B-ISDN	Broadband ISDN
B-ISUP	Broadband ISDN User Part
B-PISN	Broadband PISN
DCC	Designated Country Code
GFP	Generic Functional Protocol
GFT	Generic Functional Transport
GSM	Global System Mobile
GSTN	General Switched Telephony Network
ICD	International Code Designator
IN	Intelligent Network
IP	Internet Protocol
ISDN	Integrated Services Digital Network
LAN	Local Area Network
LANE	LAN Emulation
MC	Multipoint Controller
MCU	Multipoint Control Unit
MIB	Management Information Base
MP	Multipoint Processor
MPLS	Multi-Protocol Label Switching

MPOA	Multi-Protocol Over ATM
NSAP	Network Service Access Point
PISN	Private Integrated Services Network
PNNI	Private Network-Network Interface
PNP	Private Numbering Plan
PUM	Private Personal Mobility
PVC	Permanent Virtual Circuit
QoS	Quality of Service
RTCP	Real-Time Control Protocol
RTP	Real-Time Protocol
SCN	Switched Circuit Network
SDP	Session Description Protocol
SIP	Session-Initiated Protocol
SNMP	Simple Network Management Protocol
SVC	Switched Virtual Circuit
TCP	Transmission Control Protocol
TE	Terminal Equipment
UDP	User Datagram Protocol
UIM	User Identification Module
UPT	Universal Personal Telephony
URL	Universal Resource Locator
VHE	Virtual Home Environment

4 Introduction

4.1 Overview of H.323 and related recommendations

4.1.1 H.323 concept and entities

H.323 specifies multimedia conferencing over packet networks. This sentence already contains the keywords for noting major characteristics of H.323:

- *Multimedia* - The media mix in a call can consist of audio, video and data streams. Audio communication must be supported, video and data are optional. Media can be added, dropped or replaced dynamically during a call.

NOTE

A telefax service is being drafted for the next version of H.323.

- *Conference* - Even a two-party call is considered a special case of a multiparty conference. With regard to audio or video, multipoint conferencing can be centralized (media processing is done by a central multipoint processor, MP), decentralized (media are multicast directly from the sending party to all receiving parties), or mixed (combination of the two). Hybrid conferences combining centralized audio with decentralized video, or vice versa, are possible. Control information is always centralized via a multipoint controller (MC). Data traffic is also distributed centrally.
- *Packet network* - Although H.323 is independent of the specific transport substructure, its main sphere seems to be TCP/IP based networks (LANs/intranets or internet). The network provides a transparent transport service between communicating entities, i.e. the entities communicate end-to-end without any "exchange" or "switch" between them.

H.323 entities are terminals, gateways, gatekeepers, MCs, MPs and multipoint control units (MCUs). An MCU consists of an MC and optionally one or more MPs.

Terminals, gateways and MCUs are endpoints, which can place and accept calls (i.e., they are "callable").

A gatekeeper is not an endpoint and is "addressable" but not callable. It performs for endpoints in its "zone" tasks such as address resolution, admission control and bandwidth control.

MCs and MPs are neither addressable nor callable, but will be part of an endpoint or gatekeeper which is addressable/callable.

H.323 uses the terms *call* and *conference* in the following way:

- A call is the point-to-point multimedia communication between two H.323 endpoints, either direct or via gatekeeper(s) and/or MC(s). In case of interworking, the H.323 call consists of the section between the gateway and another H.323 endpoint.
- A point-to-point conference is the multimedia communication between two terminals irrespective of their location. In case of interworking, it contains a section between the gateway and another H.323 endpoint and also a section in the other network.
- A multiparty conference is the multimedia communication between three or more terminals irrespective of their location, but including at least one MC. A point-to-point conference becomes a multiparty conference by adding parties, and vice versa by dropping parties.

NOTE

The term ‘conference’ in H.323 corresponds to the term ‘session’ in the B-ISDN information model.

4.1.2 Channels defined in H.323

H.323 uses the concept of channels to structure the information exchange between communicating entities. The following channels are part of the communication process:

- *Call signalling channel.* This reliable channel carries information for call control and supplementary service control. The Q.931-like protocol used over this channel is specified in H.225.0 and in H.450.x (for supplementary services).
- *H.245 control channel.* This reliable channel carries the H.245 protocol for media control.
- *RAS channel.* This unreliable channel provides for communication between an endpoint and its gatekeeper. The RAS (Registration, Admission and Status) protocol is specified in H.225.0.
- *Logical channels for media.* Usually each real-time medium is carried in a separate pair of unidirectional unreliable channels, one for each direction, using the RTP and RTCP protocols. A call with audio and video therefore involves at least four logical channels. Data traffic, however, uses a bi-directional reliable channel and a protocol stack according to T.120.

In this list, a ‘reliable channel’ means connection-mode transport, while ‘unreliable’ refers to connectionless transport. In an IP-based scenario, this corresponds to TCP and UDP, respectively.

Annex C of H.323 provides a means of carrying real-time media information (audio or video) over an ATM SVC instead of over UDP/IP when an ATM path exists endstation-to-endstation. This allows the real-time media to take advantage of the QoS guarantees that ATM provides. Other H.323-related protocols are still carried over TCP/IP or UDP/IP, using an IP/ATM (e.g., MPLS, MPOA, LANE, RFC 1577, RFC 1483) technique. If audio or video is carried over ATM according to annex C of H.323, a bi-directional logical channel may be used instead of a pair of unidirectional channels, thereby resulting in a single SVC used bidirectionally instead of two SVCs used unidirectionally.

4.1.3 Protocols and related standards

H.323 itself does not specify protocols but normatively refers to a number of other recommendations: H.225.0, H.245, H.235, H.450.x, T.120 etc.

H.225.0 covers three areas:

- *Call signalling.* A protocol loosely based on Q.931 is specified for call establishment. Its main purpose is to obtain a transport address for an H.245 connection. Except in the fast connect case (see 4.1.5), where no H.245 connection exists, a call is not cleared when a call signalling connection terminates. Call clearing is normally done by H.245 signalling. However, for the sake of supplementary service usage, the H.225.0 call signalling connection may be kept until call release.
- *RAS protocol.* This protocol between endpoint and gatekeeper provides the following major functions:
 - *Gatekeeper discovery.* Enables an endpoint to find its responsible gatekeeper.

- *Endpoint Registration/Unregistration*. A terminal or gateway registers with a gatekeeper to enable participation in calls. An endpoint may unregister if it is not to take part in further calls.
 - *Admission*. Enables a terminal or gateway to get permission to set up or accept a call.
 - *Bandwidth changes*. Instructs or permits an endpoint to change the bandwidth for an existing call.
 - *Endpoint Location*. Locates endpoints based on their alias addresses and returns a transport address (IP address + port number) where they can be called.
 - *Disengage*. Informs the gatekeeper of call release or instructs the endpoint to terminate a call.
 - *Status*. Keeps the gatekeeper informed of the status of a call.
- *RTP/RTCP*. H.225.0 specifies the use of the RTP and RTCP protocols for audio and video streams in an H.323 call.

H.245 operates between two endpoints or between an endpoint and an MCU and provides the following functionality:

- capabilities exchange;
- opening and closing of logical channels;
- mode requests;
- master-slave determination;
- flow control;
- call clearing;
- media loop.

Also there are various other H.245 messages that are indicated as applicable in annex A of H.323 but for which there are no H.323-specific detailed procedures. These include round trip delay determination (can be used as a heartbeat mechanism) and various conference commands, requests and indications.

H.235 deals with security issues for H.323 calls.

H.450.x series of recommendations specifies generic procedures (H.450.1) and specific protocols for supplementary services (currently call transfer and call diversion; several others in the drafting state).

T.120 is used as data conferencing protocol. A T.120 conference is treated as a logical channel with its own protocol suite.

Another important aspect is the coding of user plane information. A number of recommendations apply here, including G.711, G.723.1, G.728, and G.729 for audio coding and H.261 and H.263 for video coding.

4.1.4 Call procedures

This subclause summarizes the steps involved in a simple H.323 call where gatekeepers are in use. A terminal can participate in a call if it has registered with its associated gatekeeper. The actual procedures may be more complex than described here since there are various options for routeing the call control and H.245 control channels – either directly between endpoints or via one or more gatekeepers. Also the adding or dropping of other parties is not considered here.

The calling terminal wishing to place a call may either know the transport address (IP address) or have an alias address of the destination (e.g. an E.164 number). In the latter case the terminal may ask the gatekeeper(s) for endpoint location, passing the alias address to the gatekeeper(s), which will return a transport address. This explicit location procedure allows multicasting of the request to many gatekeepers. Usually, however, the address resolution is implicit in the admission procedure between an endpoint and its associated gatekeeper, as described below.

The first step of call establishment is taken by the terminal by asking the gatekeeper for call admission, passing the destination (alias and/or transport) address to the gatekeeper. If granted admission, the

terminal will send a SETUP message to the transport address returned by the gatekeeper. At the destination side, the called endpoint asks its gatekeeper for admission to accept the incoming call. If granted, the call will be accepted, and a transport address for the H.245 control channel is returned to the calling endpoint. The H.245 control channel is then established, and the further call related signalling is done via H.245: exchange of capabilities between calling and called endpoint, master-slave determination, opening and closing of logical channels etc. Once a logical channel is open, user data can be sent on it. During the lifetime of a call an endpoint and its associated gatekeeper may exchange status messages or bandwidth change messages. A call is cleared by closing all logical channels, sending a command to end the session (call) on the H.245 control channel and releasing the H.245 control channel. The call control channel can be released at any time after the H.245 control channel is established, at the latest at call clearing.

4.1.5 Fast connect

Fast connect is an option specified in 8.1.7 of H.323 that reduces the number of round trip delays involved in establishing a call and initial media streams by including H.245 open logical channel information in the SETUP and CONNECT messages. A separate H.245 channel using its own TCP connection may or may not subsequently be established, depending on the need for further channel opening and closing during the call. Fast connect is also mandated in the new H.323 annex F (“Single Use Device”), currently determined in Study Group 16.

Related to this is the use of UDP instead of TCP for signalling, as specified in new H.323 annex E. Both annex E and annex F will appear in H.323 version 3 shortly.

4.1.6 Inter-domain signalling

A new annex G to H.225.0, currently in a “determined” state in SG16, covers inter-domain address resolution aspects. The protocol operates between administrative domain border gatekeepers and between border gatekeepers and clearing houses. It allows an administrative domain to obtain routing addresses for calls to destinations in other domains.

4.2 Overview of modelling work relating to B-ISDN signalling

Work under Question 6 in ITU-T Study Group 11 has developed in document TRQ-2001 an information model for future B-ISDN signalling capabilities. The information model comprises a number of object classes and associations. Object classes are grouped into four service levels as follows:

- session service level;
- resource service level;
- call service level;
- bearer service level.

The majority of the object classes involved are shown in figure x/TRQ.2001 reproduced in figure 1.

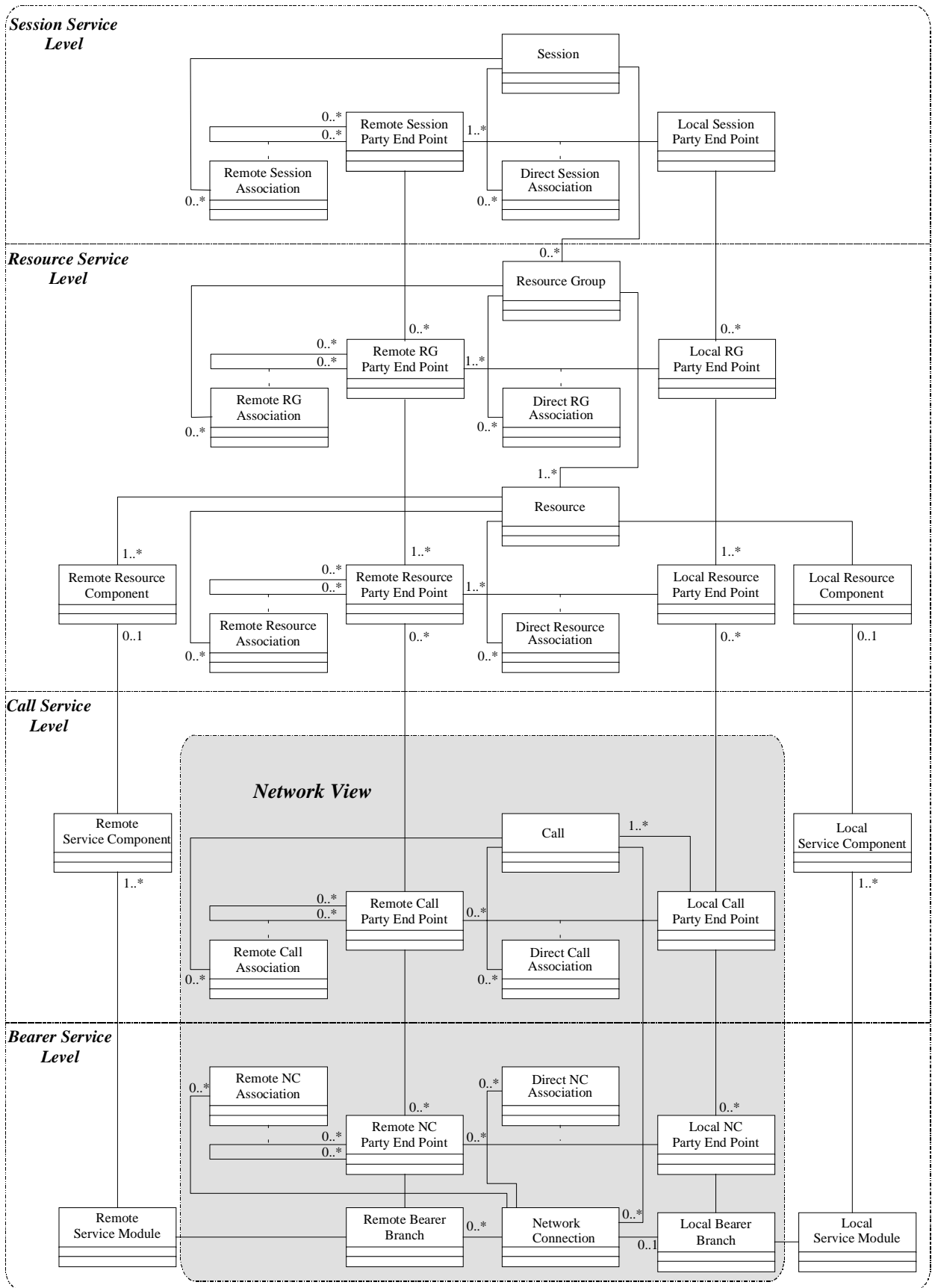

Figure 1 – Object classes and associations (from TRQ.2001)

The model also shows that the network has a view of some of the object classes at the call and bearer service levels, but other object classes, including all object classes at the session and resource service levels, do not appear in the network view. All object classes are in principle visible to endstations.

NOTE

This does not preclude the siting of endstation functionality within a network (e.g., a server that behaves as an endstation), in which this restriction does not apply.

Where information exchange is required at these service levels, corresponding protocols are employed, i.e., session control, resource control, call control and bearer control protocols. Whereas the network is involved in call and bearer control protocols, session and resource control protocols normally operate end-to-end between endstations. Likewise some aspects of call and bearer control protocols operate end-to-end between endstations, e.g., low and high layer information, AAL parameters.

Protocols will not always be required at all levels. For example, for certain types of communication call control and bearer control are sufficient, without a need for session control and resource control protocols. On the other hand, communications that use permanently-provisioned network capabilities (e.g., PVCs) do not need bearer control and call control protocols, but may still need session and resource control protocols.

4.3 Overview of B-ISDN signalling - combined call/bearer control

None of the published B-ISDN signalling protocols to date attempt to provide the separation between call and bearer control that the model permits. Combined call control and bearer control protocols provide a means of simultaneously establishing and simultaneously releasing a call together with a single bearer. The concept of a call having more than one bearer is not supported. Protocols for basic call/bearer control include:

- ITU-T recommendation Q.2931 (in conjunction with certain other recommendations from the Q.29xx series) for DSS2 (applicable at the T reference point and at coincident S and T reference points);
- ITU-T recommendations Q.2761 to Q.2764 (in conjunction with certain other recommendations from the Q.27xx series) for B-ISUP (part of Signalling System no. 7);
- ISO/IEC 13247 for B-QSIG (applicable at the Q reference point between two Private Integrated Services network eXchanges);
- layer 3 aspects of the ATM Forum's UNI 4.0 specification;
- signalling aspects of the ATM Forum's PNNI 1.0 specification;
- the ATM Inter-Network Interface (AINI) specification currently under development in the ATM Forum.

4.4 Overview of B-ISDN signalling - separated call and bearer control

Driven heavily by work in ETSI SPS5/WG5 and ECMA TC32-TG15, draft ITU-T recommendations exist for separated call control and bearer control protocols (Q.29cc-ROSE and Q.298x-sbc respectively). ECMA intends to adopt Q.29cc-ROSE also for broadband private networks (as B-QSIG separated call control) and to produce a B-QSIG bearer control protocol standard based on Q.298x-sbc.

These recommendations and standards exploit the separation in the model between call control and bearer control, and in particular allow:

- the existence of more than one bearer per call; and
- the routing of bearers independently of each other and independently of the routing of call control signalling.

The call control protocol operates between Call Control (CC) entities, typically located only in terminals and edge switches. The bearer control protocol, on the other hand, operates between Bearer Control (BC) entities located in terminals and in each switch through which the bearer is routed. Coordination between call control and bearer control takes place only at those locations where there are CC entities. Thus each bearer has freedom to choose its own route between these locations. This is illustrated (for a single bearer) in figure 2 (extracted from Q.29cc-ROSE).

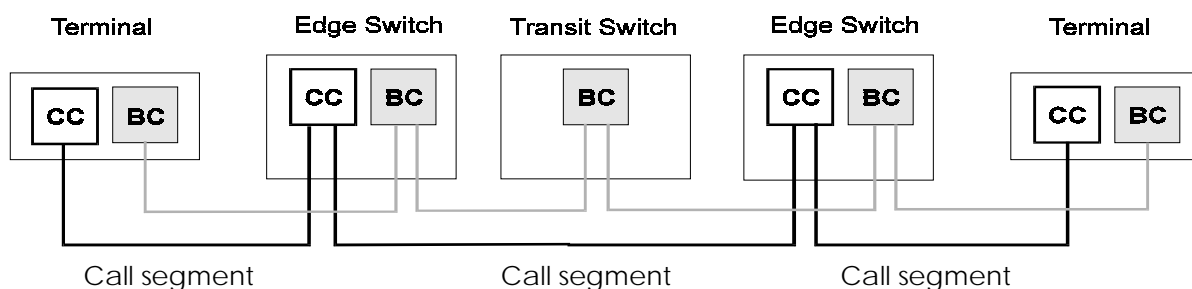

Figure 2 – Relationship between call control and bearer control architectures (from Q.29cc-ROSE)

The call control protocol uses an object model as its basis. A number of call-related object classes are defined, such as call, party, bearer and service component. A particular call is defined in terms of an object model, comprising one or more object instances of one or more of these object classes. The call control protocol has the following capabilities:

- creation of an object model at call establishment time, including initial object instances;
- modification of the object model during the lifetime of a call, including creation and destruction of object instances and modification of the attributes of object instances;
- destruction of the object model when a call is terminated, including the destruction of any remaining object instances.

This has a number of advantages, including:

- easy enhancement of the call control protocol, simply by defining new object classes or new attributes of existing object classes;
- easy adaptation of the protocol to other levels of the model or even to entirely different applications, simply by defining new sets of object classes.

By contrast, the bearer control protocol is a simple adaptation of the corresponding combined call/bearer control protocol for the interface concerned, e.g., DSS2 call/bearer control or B-QSIG call/bearer control. The adaptation is primarily to transport a reference to a call, so that a switch or terminal can associate an incoming bearer with a call.

5 Related work

5.1 ECMA TC32-TG15 and ETSI SPS5 WG5

ECMA TC32-TG15 and ETSI SPS5 WG5 are working together to produce separate call control and bearer control protocol standards for B-PISN and B-ISDN, as described in 4.4. The first phase deals only with point-to-point calls, but future phases are expected to extend the protocols to the support of multi-party calls. The work is also being contributed to ITU-T Study Group 11, where initial recommendations are expected to be approved early in 1999.

Other work pursued jointly includes the enhancement of the generic functional protocols for the support of supplementary services (Q.2932.1 and ECMA-254) to support inter-networking, taking on board the recommendation (currently in draft form) Q.gft, which provides similar extensions for narrowband..

5.2 ITU-T Study Group 16

ITU-T Study Group 16 is responsible for Recommendation H.323 and all supporting Recommendations, including H.225.0, H.245, H.235, H.246 and the H.450-series of Recommendations on supplementary services. Currently H.323 version 2 is complete and work is in progress on version 3 (along with corresponding new versions of supporting Recommendations). Approved Recommendations in the QSIG-based H.450 series are the generic functional protocol (H.450.1), call transfer (H.450.2) and call diversion (H.450.3). Work is in progress on other supplementary services for this series, including call hold, call waiting, call park/pick-up, number/name identification and message waiting indication.

5.3 ETSI project TIPHON

5.3.1 General

TIPHON stands for Telecommunications and Internet Protocol Harmonization Over Network (TIPHON).

The objective of the TIPHON project is to support a market that combines telecommunications and Internet technologies to enable communications over Internet Protocol (IP)-based networks to work with existing Switched-Circuit Networks (SCN) and vice versa. An SCN is a switched telecommunications network, e.g. PSTN, ISDN, GSM, that uses circuit-switched technologies for the support of voice calls. The SCN may be a public network or a private network. The focus is on interoperability between the two networks and not on the actual individual network itself. DTR/TIPHON-00001 contains the overview for the TIPHON project.

The TIPHON project will be divided into four scenarios as follows:

- **Scenario 1:** communication between IP network based users and SCN users, in which the call set-up is originated by the IP network user (see figure 3).
- **Scenario 2:** communication between IP network based users and SCN users, in which the call set-up is originated by the SCN user (see figure 4).
- **Scenario 3:** communication between SCN users, using IP based networks for the connection/trunking between the involved users (see figure 5).
- **Scenario 4:** communication between IP network based users, using SCN for the connection/trunking between the involved users (see figure 6).

The life cycle of the project should come to completion in the early 1999 with the completion of the interoperability tests.

The production of deliverables will be structured in 3 project phases:

- Project Phase 1, covering all issues for scenario 1;
- Project Phase 2, covering all issues for scenarios 1 and 2;
- Project Phase 3, covering all issues for scenarios 1, 2, 3 and 4 and amendments to documents of Phase 1 and 2.

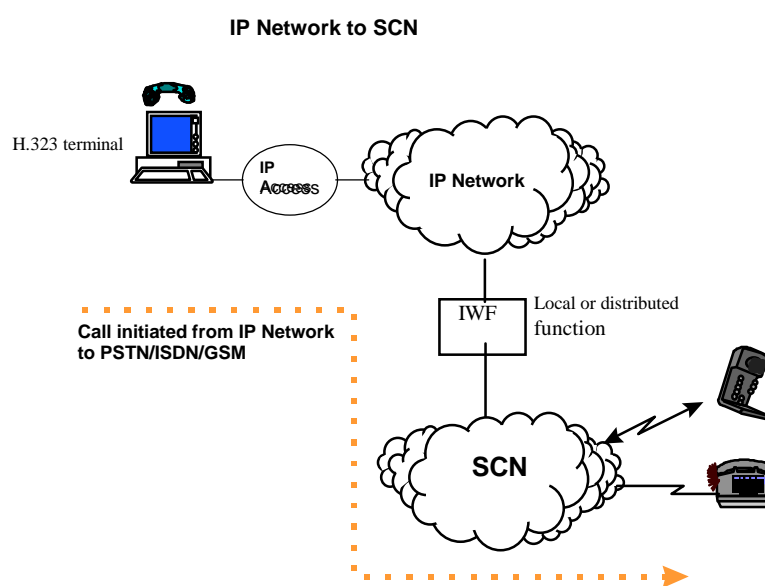

Figure 3 – TIPHON Phase 1 - IP Network to PSTN/ISDN/GSM

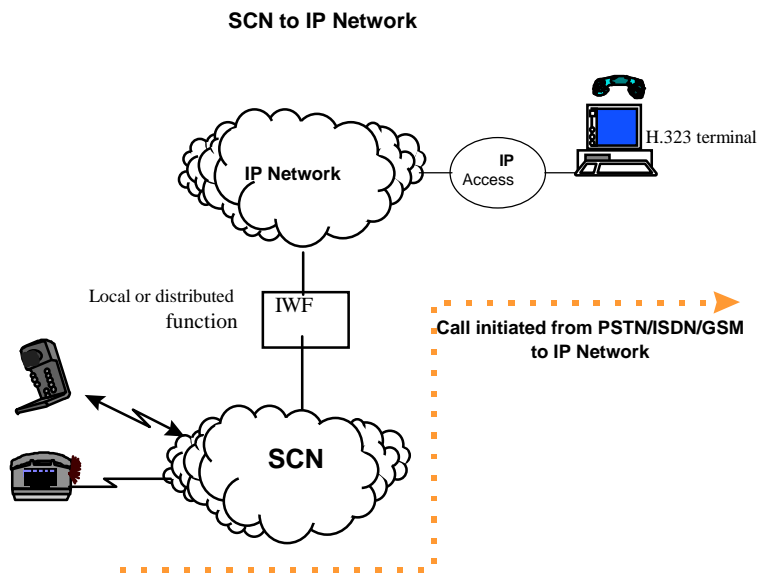

Figure 4 – TIPHON Phase 2 - PSTN/ISDN/GSM to IP Network

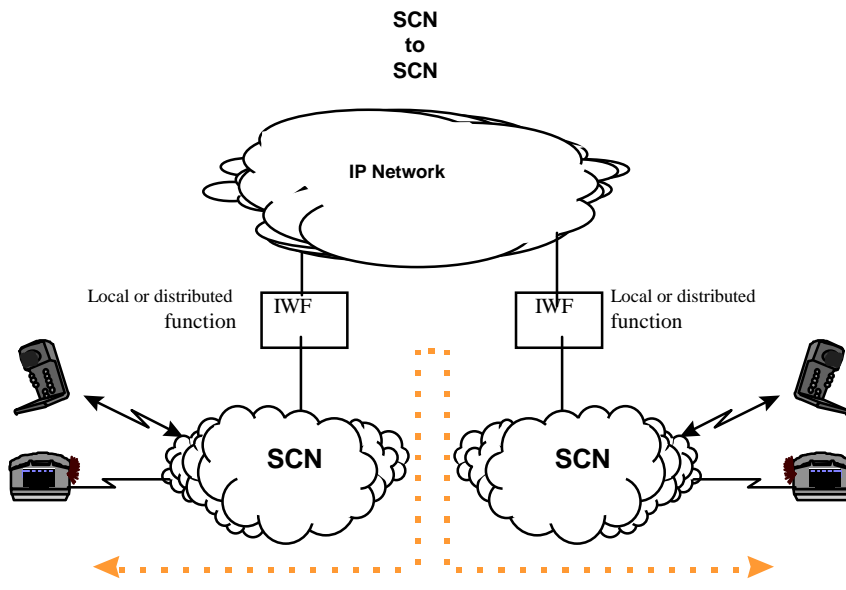

Figure 5 – TIPHON Phase 3 - PSTN/ISDN/GSM to PSTN/ISDN/GSM over IP network

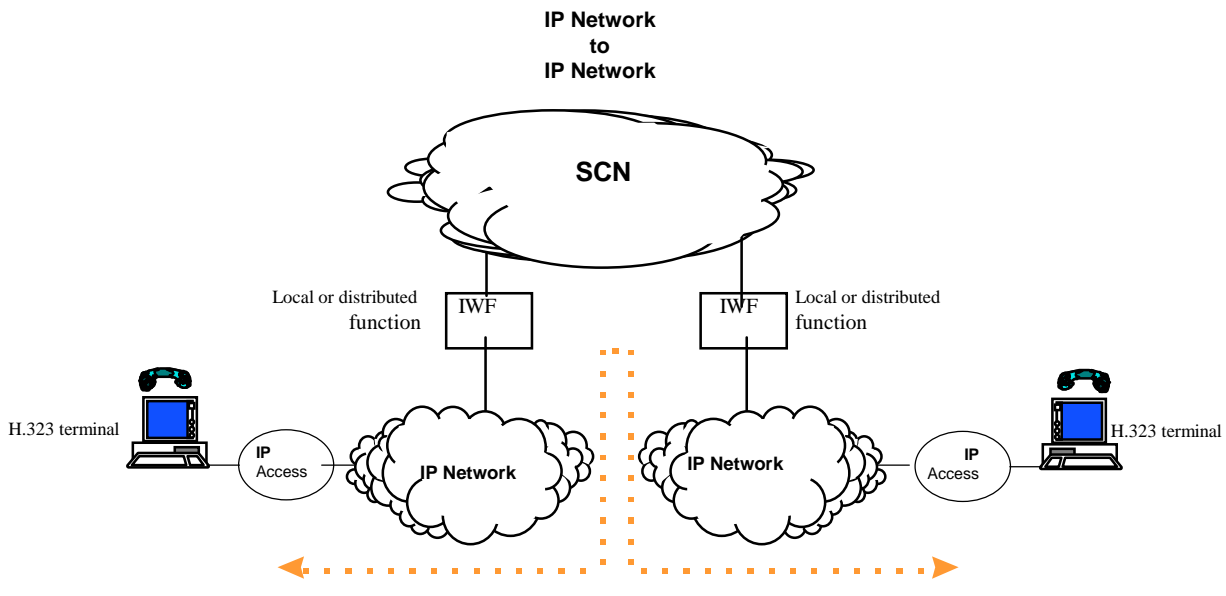

Figure 6 – TIPHON Phase 4 - IP network to IP network over PSTN/ISDN/GSM

5.3.2 Gateway functional decomposition

There has been a significant amount of work in TIPHON on the functional decomposition of an H.323 gateway, to allow various gateway physical architectures to be used to exploit different SCN architectures (e.g., SS7, IN). The current draft DTR/TIPHON 02002 (architecture document for phase 2) contains a reference configuration that identifies the following functional components within a gateway:

- media gateway (user plane functionality, e.g., RTP);
- media gateway controller (H.323 control plane functionality, e.g., H.245);
- signalling gateway (SCN signalling functionality, e.g., SS7).

Also a number of reference points are identified. Of particular significance is the “N” reference point between the media gateway function and the media gateway controller function, for which a protocol is being drafted in IETF (see 5.6.4) and contributed to TIPHON.

5.4 ATM Forum SAA/RMOA

The ATM Forum SAA/RMOA group is specifying an Implementation Agreement for a Real-time Multimedia Over ATM service including telephony, video-conferencing and distance learning based on the exchange of audio, video and data. It describes the access to an ATM network using H.323. The H.323 terminal can be on a variety of network technologies, including non-native ATM IP-based (Ethernet, etc.), and native ATM. The document will also cover interworking with other multimedia terminals on ATM or other network technologies, as well as with SCN.

In particular the group is examining ways in which the H.323 media stream information can be transported in an ATM network, including:

- IP over ATM media stream transport (H.323),
- RTP over ATM media stream transport (H.323 annex C),
- Compressed RTP/UDP/IP over ATM media stream transport.

5.5 ECMA TC32-TG13

ECMA TC32-TG15 is considering opening work items relating to interworking between private narrowband networks and IP networks employing H.323, and also trunking of QSIG over IP. As there is some overlap with the TIPHON project, some of the results of this work will be fed into TIPHON.

5.6 IETF

5.6.1 SIP

SIP (Session Initiation Protocol) is an alternative to H.323 that currently does not have much acceptance in the commercial world, but a few individuals are pushing to develop it as a voice over IP protocol. It is also used for other applications.

5.6.2 IPTEL

IPTEL is looking at user location and finding gateways that will connect an Internet call onto the GSTN at the most economical point.

5.6.3 E.164 Birds of a Feather activity

This is addressing the difficult problem of mapping E.164 addresses to IP addresses globally in a scaleable manner.

5.6.4 NAVDEC

NAVDEC (Network Access Server and Voice on IP Device Control) assumes the functional decomposition as mentioned under TIPHON (see 5.3.2) and focuses on controlling media gateways from external entities such as media gateway controllers (across the “N” reference point), e.g., using the Media Gateway Control Protocol (MGCP).

6 H.323 and modelling of B-ISDN signalling

The relationship between H.323 and the B-ISDN signalling information model in TRQ-2001 appears to be as follows:

1. The H.225.0 “call control” protocol used by H.323 appears to serve as a session control protocol, since its principle aim is to establish a session between two endpoints. For this reason, this protocol is referred to as H.225.0 session control throughout the rest of this document. A B-ISDN session can perhaps equate to an H.323 conference.
2. The H.245 protocol used by H.323 appears to serve as a resource control protocol, since its principle function is to control resources (in the form of “logical channels”) between endpoints.

In a LAN environment, bearers are “provisioned”, i.e., permanently available, and consequently no bearer control protocol is needed. Because there are no bearers to be controlled, there is also no call control. The network does not have a view of an H.323 communication at all. The same applies to an annex C environment in which ATM PVCs are used to carry media streams.

In an annex C environment in which ATM SVCs are used to carry media streams, the protocol used to establish and release the SVCs can be regarded as a combined call and bearer control protocol.

NOTE

The encapsulation of H.245 messages within H.225.0 “call control” messages in the context of fast connect might be the start of a trend that blurs the distinction between session control and resource control.

7 H.323 interworking via a gateway with B-ISDN separated call and bearer control

The ability to interwork between H.323 and B-ISDN separated call and bearer control would enable the following possibilities:

- a) use of B-ISDN separated call and bearer control in the “core network” but supporting H.323 endstations;
- b) interworking between H.323 endstations and native ATM endstations employing B-ISDN separated call and bearer control;
- c) interworking between H.323 endstations and native ATM endstations employing B-ISDN combined call/bearer control, provided a further capability exists to interwork between B-ISDN separated and combined control environments.

For possibility a), the “core network” could, for example, be the entire B-ISDN environment (public and private B-ISDNs) or just the public B-ISDN environment (thereby using H.323 within private networks).

Possibility c) would, in principle, achieve the same as direct interworking between H.323 and B-ISDN combined call/bearer control.

7.1 Scenarios

Three scenarios can be identified, according to the way session control and resource control are provided in the B-ISDN environment.

Scenario 1: null session control and resource control in B-ISDN environment.

Scenario 2: each environment operates its own session and resource control protocols;

Scenario 3: end-to-end session and resource control protocols.

With scenario 1 (figure 7), the H.323 session and resource control protocols are terminated at the interworking unit. Because there is no session or resource control protocol in the B-ISDN environment, the gateway may need to provide mapping between session and/or resource control protocol elements in the H.323 environment and call and/or bearer control protocol elements in the B-ISDN environment.

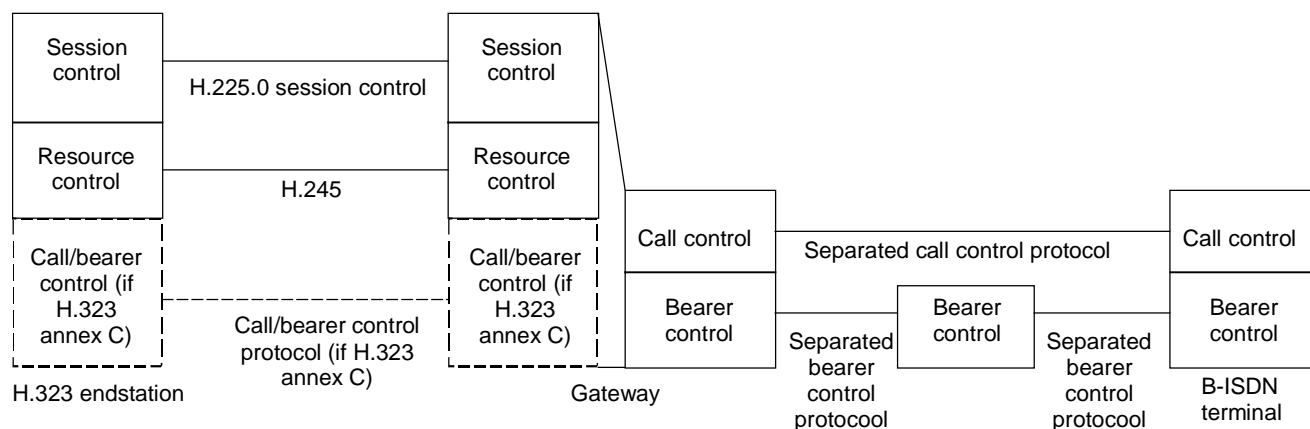

Figure 7 – Interworking with a separated call and bearer control environment - scenario 1

In this scenario, the B-ISDN separated call control protocol needs to provide some aspects of session/resource control. In particular, it needs to bind together the multiple bearers carrying the various media.

NOTE

Alternatively, there could be multiple instances of the separated call control protocol (e.g., one per medium), but with the absence of session/resource control protocols there would be nothing to bind the different instances together.

With scenario 2 (figure 8), session and resource control protocols in the two environments can be the same (i.e., H.225.0 session control and H.245 in both environments) or different (i.e. new protocols in B-ISDN), but in either case the gateway terminates these protocols and provides mapping between the two environments. Because the gateway is involved in session and resource control, these can impose control on call control and/or bearer control at the gateway.

With a resource control protocol to bind together the different media, the separated call control protocol does not need to perform this function. Therefore each bearer can (but need not) have its own instance of the separated call control protocol.

The existing call control protocol could easily be adapted to provide a B-ISDN session or resource control protocol, by defining new object classes. Alternatively the H.323 session and/or resource control protocols could be re-used in the B-ISDN environment. Even if protocols are the same in the two environments, with this scenario the protocols are terminated at the gateway.

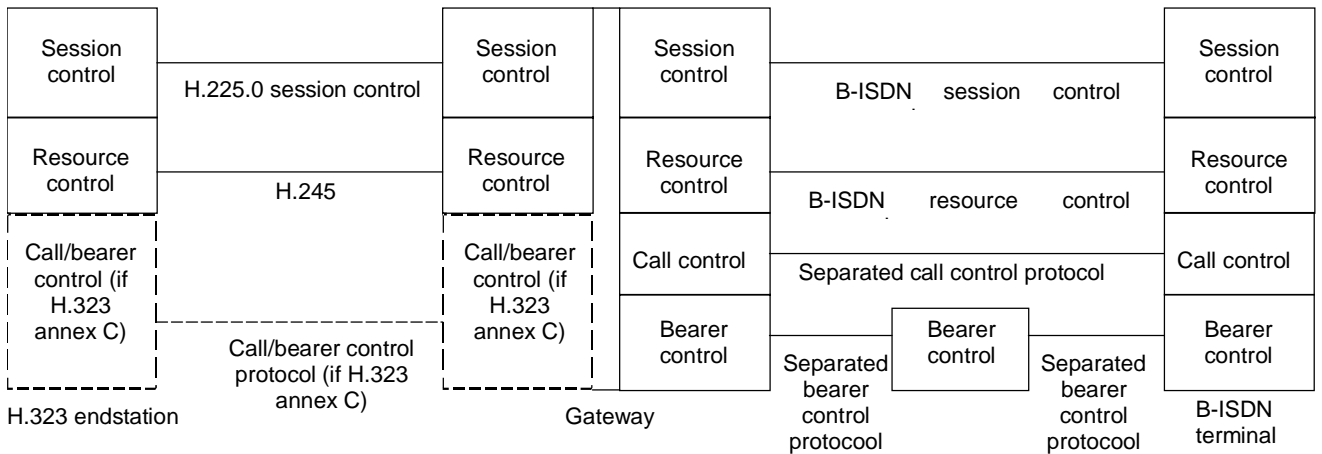

Figure 8 – Interworking with a separated call and bearer control environment - scenario 2

With scenario 3 (figure 9), the gateway is not involved with session and resource control protocols, which pass transparently between the two environments as user plane information. The H.323 session and resource control protocols (H.225.0 session control and H.245) are assumed to be used.

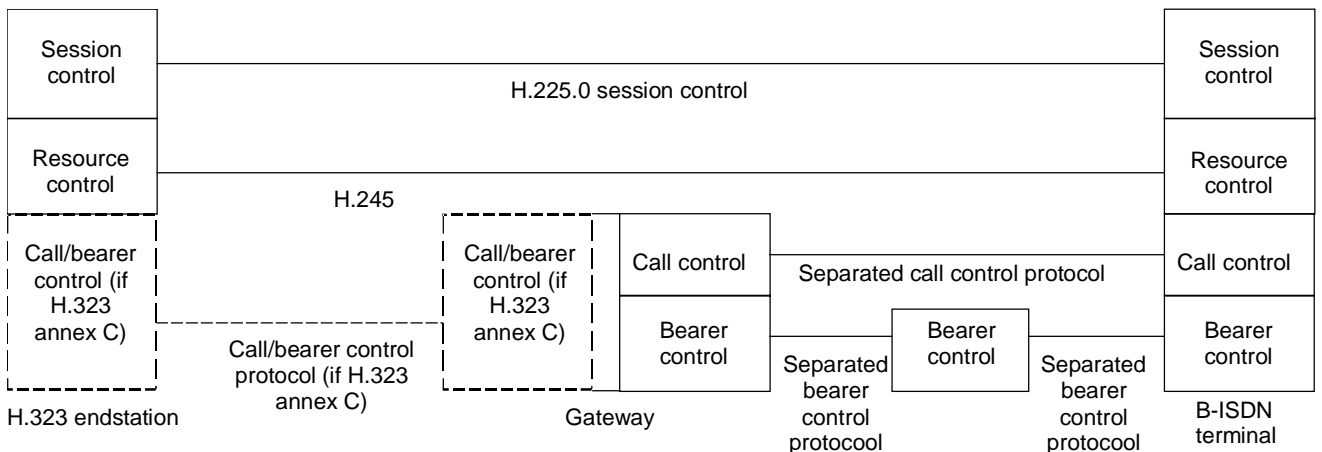

Figure 9 – Interworking with a separated call and bearer control environment - scenario 3

This scenario requires each logical channel in the H.323 environment to map onto a separate instance of the separated call control protocol in the B-ISDN environment, since there is no resource control involvement at the gateway to bind calls together.

The theoretical alternative of an end-to-end session control protocol but resource control terminated at the gateway does not seem to make sense, since resource control needs to be under the control of session control.

For each scenario, considerations vary according to whether the H.323 environment is LAN-based or ATM-based, and in the latter case depending on whether annex C is used for real-time media streams. Therefore for each scenario, three sub-scenarios can be identified:

Sub-scenarios 1a, 2a and 3a: LAN-based H.323 environment.

Sub-scenarios 1b, 2b and 3b: ATM-based H.323 environment not using annex C.

Sub-scenarios 1c, 2c and 3c: ATM-based H.323 environment using annex C.

In 7.2.3 it is shown that sub-scenarios 3a and 3b are not feasible.

7.2 Protocol interworking architecture

7.2.1 Scenario 1

To an H.323 endstation, the totality of the interworking functions (control interworking and media interworking) appears as an H.323 gateway. All bearers are constrained to pass through the same gateway as session and resource control.

7.2.1.1 Sub-scenario 1a – null session/resource control in B-ISDN – LAN-based H.323 environment

The model for protocol interworking according to scenario 1a is shown in figure 10.

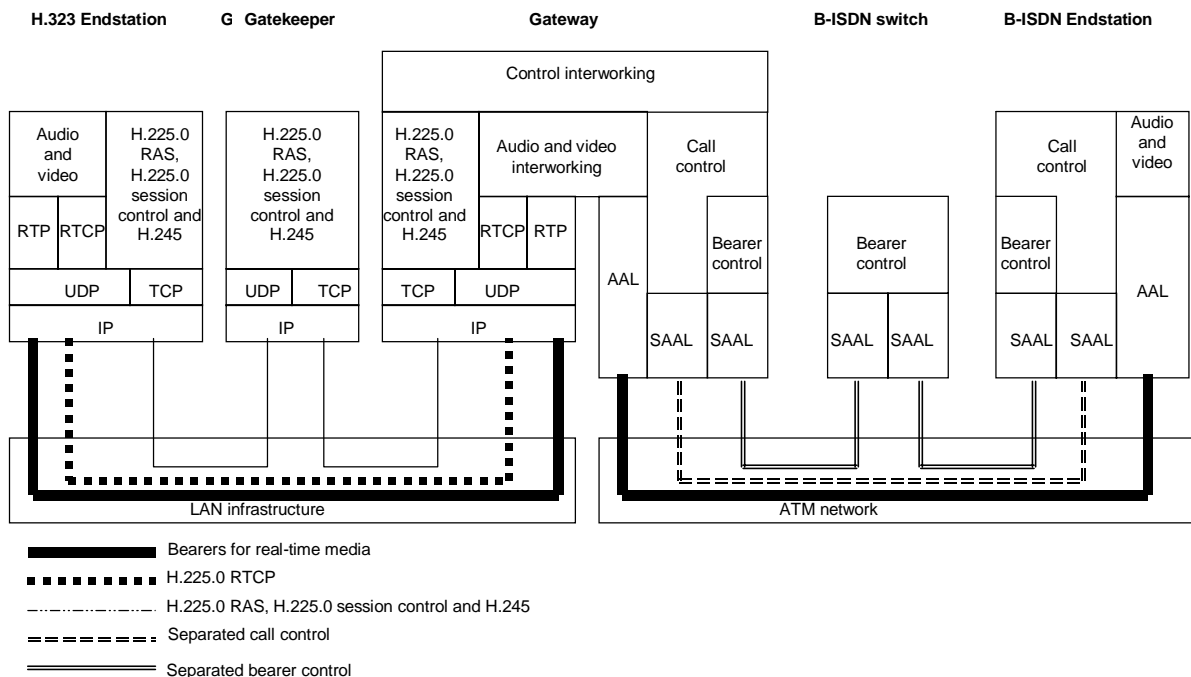

Figure 10 – General model for interworking between H.323 and B-ISDN separated call and bearer control according to scenario 1a

7.2.1.2 Sub-scenario 1b – null session/resource control in B-ISDN – IP-over-ATM-based H.323 environment without H.323 annex C

The model for protocol interworking according to scenario 1b is shown in figure 11.

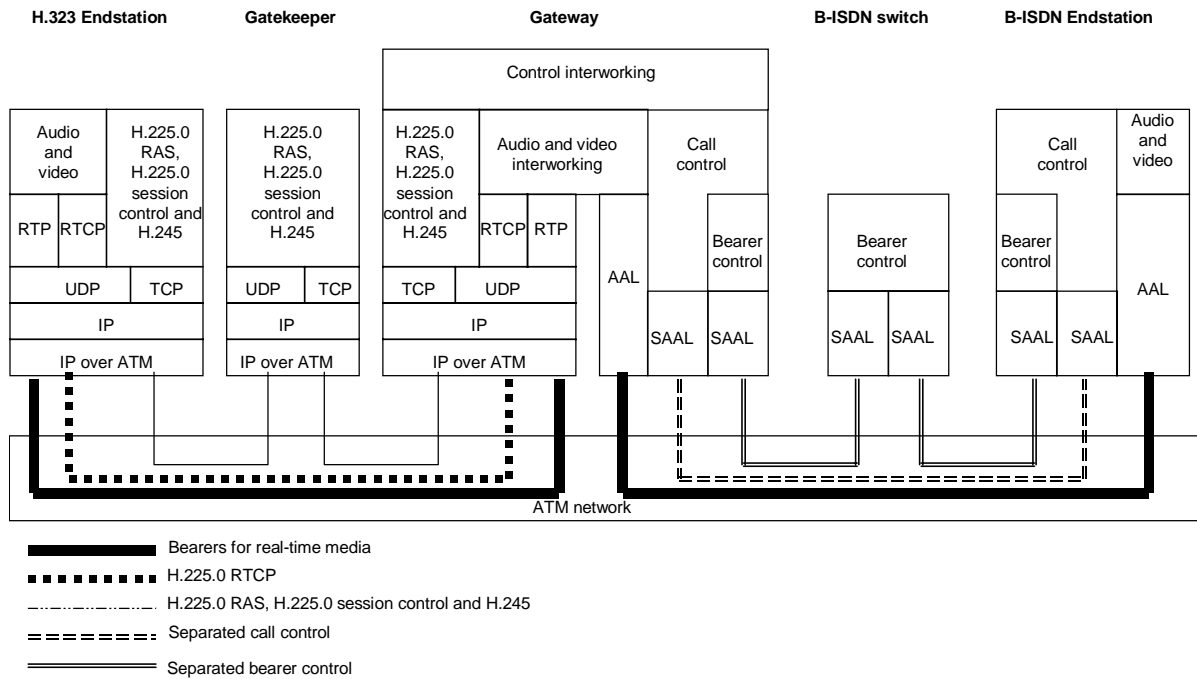

Figure 11 – General model for interworking between H.323 and B-ISDN separated call and bearer control according to scenario 1b

7.2.1.3 Sub-scenario 1c – null session/resource control in B-ISDN – use of H.323 annex C in H.323 environment

The model for protocol interworking according to scenario 1c is shown in figure 12.

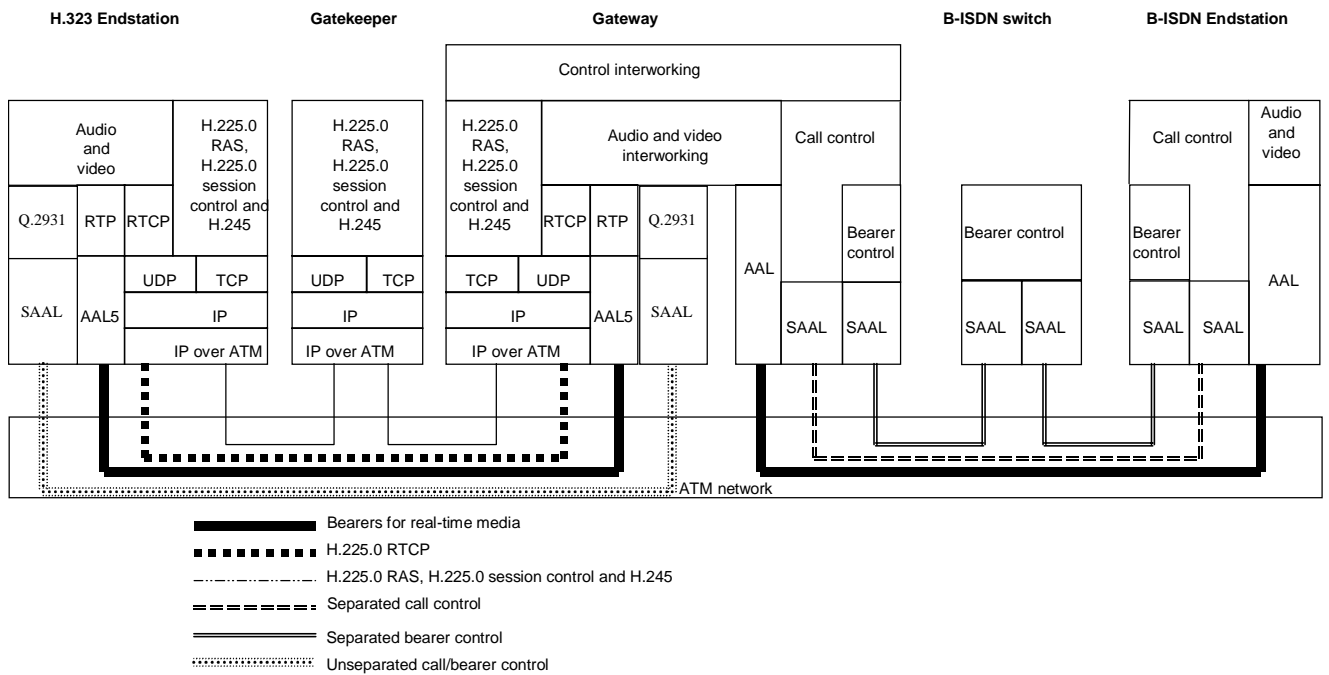

Figure 12 – General model for interworking between H.323 (annex C) and B-ISDN separated call and bearer control according to scenario 1c

SVCs in support of H.323 real-time media carry RTP on top of AAL5. On the other hand, SVCs in the B-ISDN environment do not carry RTP and may use a different AAL (e.g., AAL1). Therefore there is at least some media interworking to be performed, and SVCs cannot be established directly

between the H.323 endstation and the point of call/bearer coordination in the B-ISDN environment, by-passing the point of control interworking. Thus the point of interworking must have a gateway appearance to H.323 endstations, and not a gatekeeper appearance.

The presence of RTP in the SVC user plane stack leads to some bandwidth inefficiency due to the presence of the RTP header in every packet. On the other hand, it simplifies any interworking that might take place between an H.323 annex C environment and an H.323 environment not employing annex C.

NOTE

Such interworking would be further simplified if UDP and IP headers were also included in every packet, but this would lead to further bandwidth inefficiency. The ATM Forum SAA/RMOA group is investigating ways of improving the efficiency by using a “compression” technique on the RTP, UDP and IP headers. The principle behind this technique is to avoid sending header information when nothing has changed since the previous packet. This simplifies interworking between H.323 environments employing annex C and not employing annex C, thus significantly reducing the impact on bandwidth. However, this would still require media interworking between an H.323 annex C environment and a native ATM environment.

7.2.2 Scenario 2

To an H.323 endstation, the totality of the interworking functions (control interworking and media interworking) appears as an H.323 gateway. All bearers are constrained to pass through the same gateway as session and resource control.

7.2.2.1 Sub-scenario 2a – each environment operates own session/resource control protocols – LAN-based H.323 environment

The model for protocol interworking according to scenario 2a is shown in figure 13.

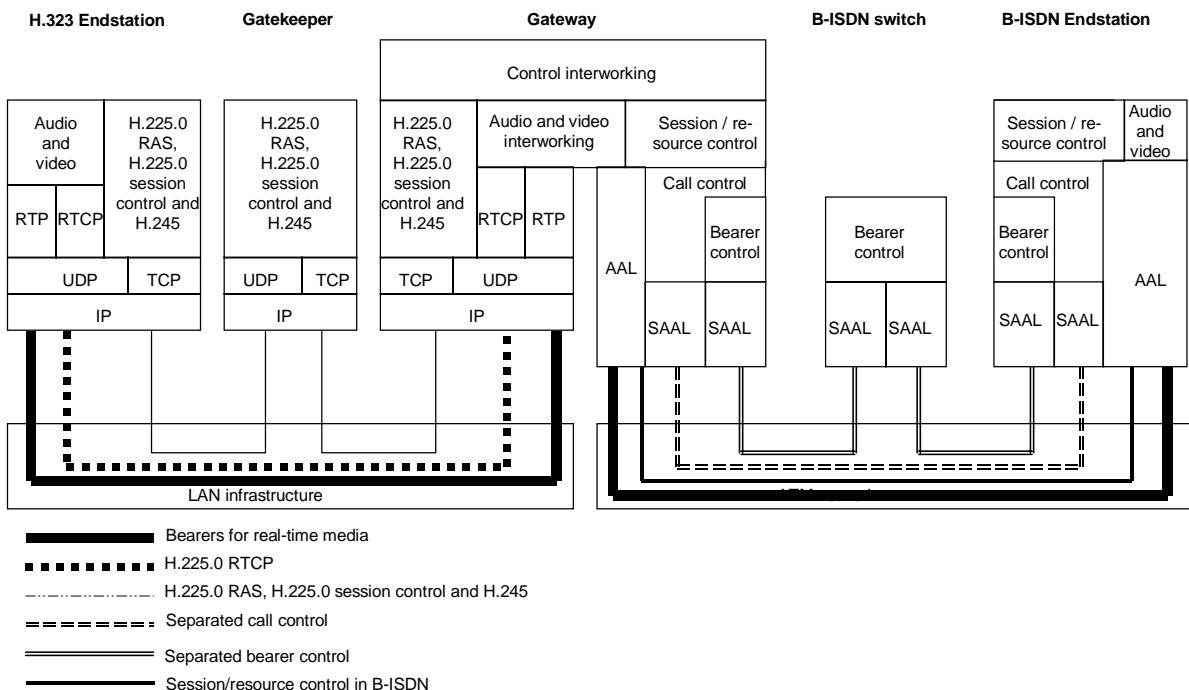

Figure 13 – General model for interworking between H.323 and B-ISDN separated call and bearer control according to scenario 2a

7.2.2.2 Sub-scenario 2b– each environment operates own session/resource control protocols – IP-over-ATM-based H.323 environment without H.323 annex C

The model for protocol interworking according to scenario 2b is shown in figure 14.

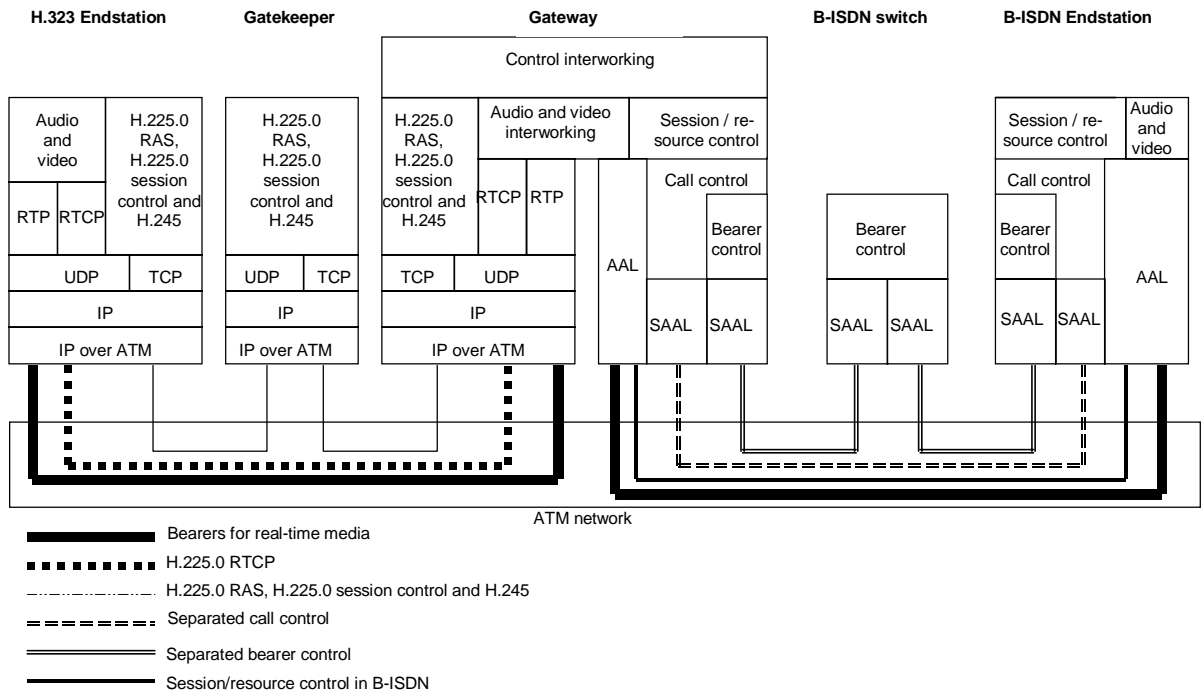

Figure 14 – General model for interworking between H.323 and B-ISDN separated call and bearer control according to scenario 2b

7.2.2.3 Sub-scenario 2c– each environment operates own session/resource control protocols – use of H.323 annex C in H.323 environment

The model for protocol interworking according to scenario 2c is shown in figure 15.

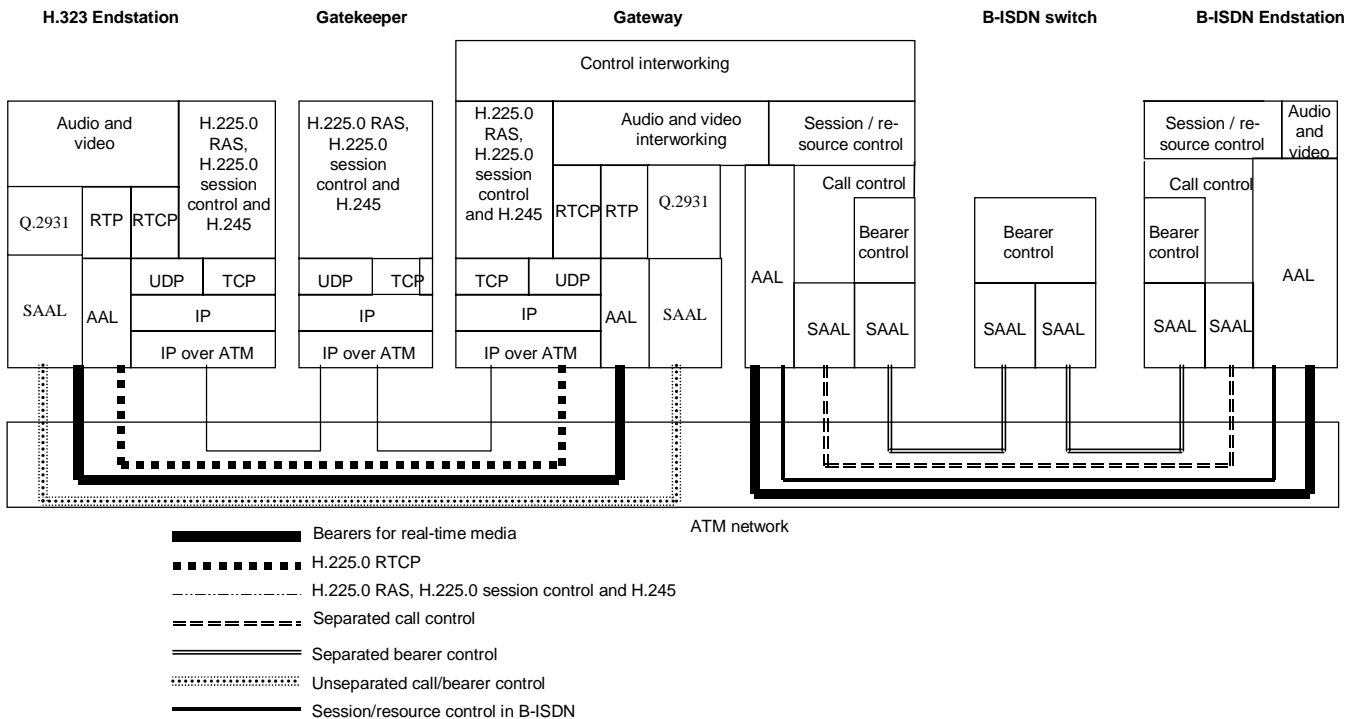

Figure 15 – General model for interworking between H.323 (annex C) and B-ISDN separated call and bearer control according to scenario 2c

Considerations regarding the presence of RTP in the SVC user plane and the interworking of real-time media streams are as for scenario 1c.

7.2.3 Scenario 3

This scenario suffers from the general problem that the lack of resource control functionality at the boundary between the two environments means that there can be no resource control influence on the interworking of media streams. This rules out sub-scenarios 3a and 3b, since the dissimilar media stream transport mechanisms each need to be terminated at the interworking point under the control of resource control. Sub-scenario 3c is possible, provided the SVCs for the real-time media extend end-to-end, without termination at the interworking point. This requires the SVC payloads to be the same in the two environments, which means either omitting RTP, UDP and IP headers in the annex C environment or including these (perhaps in compressed form) in the native ATM environment. Interworking between combined call/bearer control in the annex C environment and separated call and bearer control in the native ATM environment can take place autonomously, i.e., without any direction from resource control.

7.2.3.1 Sub-scenario 3c – end-to-end session/resource control protocols – use of H.323 annex C in H.323 environment

The model for protocol interworking according to scenario 3c with RTP, UDP and IP all carried end-to-end (perhaps compressed) in the real-time media stream SVCs is shown in figure 16. Also RTCP is assumed to be carried end-to-end. No assumption is made about the number and type of SVCs to be used for carrying H.225.0 session control, H.245 resource control and RTCP within the native ATM environment.

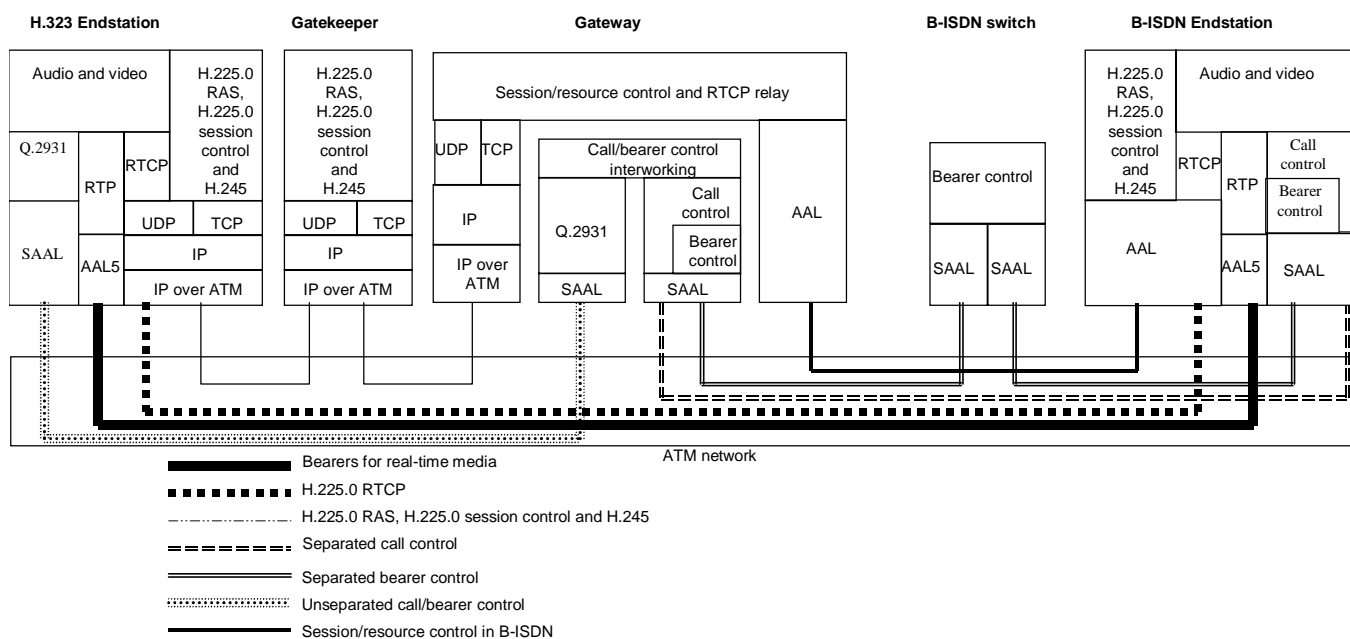

Figure 16 – General model for interworking between H.323 (annex C) and B-ISDN separated call and bearer control according to scenario 3c

NOTE

The use of gatekeepers and the RAS protocol in the B-ISDN environment requires further study.

7.3 Session control in B-ISDN environment

H.225.0 session control could be re-used as the session control protocol in the B-ISDN environment for scenario 2. The protocol would be carried in an SVC.

An alternative candidate would be to write a new session control protocol based upon the existing call control protocol but with a different set of object classes to reflect those objects that need to be manipulated at the session control level. Since the call control protocol is essentially a means of creating,

manipulating and destroying an object model, this should be easy to achieve. However, it would need to be done in a way that would make interworking with H.225.0 session control at a gateway reasonably simple. Candidate object classes would be session, local and remote session party endpoints and direct and remote session associations.

7.4 Resource control in B-ISDN environment

H.245 could be re-used as the resource control protocol in the B-ISDN environment for scenario 2. Because the logical channels would always be SVCs, those aspects of H.245 that relate to H.323 annex C would be employed. H.245 would be carried either in its own SVC or in an SVC being used by session control.

There may be capabilities in H.245 that are not used by H.323 but may be applicable in a B-ISDN environment. This should be investigated if H.245 is to be considered for B-ISDN.

An alternative candidate would be to write a new resource control protocol based upon the existing call control protocol but with a different set of object classes to reflect those objects that need to be manipulated at the resource control level. Since the call control protocol is essentially a means of creating, manipulating and destroying an object model, this should be easy to achieve. However, it would need to be done in a way that would make interworking with H.245 at a gateway reasonably simple. Candidate object classes would be resource, local and remote resource party endpoints, local and remote resource components and direct and remote resource associations. The need to encompass the concept of resource groups would need investigation.

7.5 Call establishment

For scenario 1, there is a need for the gateway to map between the session control protocol used in the H.323 environment and B-ISDN separated call control. Mapping should be fairly straightforward, but one area that may need attention is mapping between the H.225.0 session control (Q.931) Bearer capability information element (BC) and the B-ISDN service component type. BC essentially has no meaning when received at a destination endpoint, but is included by an originating endpoint to provide information that might be of use if a gateway is encountered. Basically it provides information to enable a gateway to determine if the call is voice only or multimedia and how many bearers it will need.

NOTE

This BC mapping should be similar to that between ISDN (narrowband) and B-ISDN separated call and bearer control.

For scenario 2, call establishment occurs independently in the two environments, each under the control of the respective resource control protocol. For the H.323 environment, call establishment applies only to sub-scenario 2c and uses combined call/bearer control in accordance with H.323 annex C. For the B-ISDN environment there can be a single call (supporting multiple bearers) or multiple calls (each supporting one or more bearers). The former might require a change to H.245, if this is used as the resource control protocol in the B-ISDN environment.

For scenario 3 (sub-scenario 3c), call establishment is end-to-end. However, because H.323 annex C requires the use of combined call/bearer control in the H.323 environment, the gateway will need to perform interworking between combined call/bearer control and separated call and bearer control, and this implies the use of one call per bearer in the B-ISDN environment, to keep this interworking simple. Enhancement of H.323 annex C to allow the use of separated call and bearer control would remove the need for this interworking.

7.6 Bearer establishment

For scenarios 1 and 2, bearer establishment occurs independently in the two environments. In the H.323 environment, bearer control is combined with call control (sub-scenarios 1c and 2c only). In the B-ISDN environment, bearer control occurs within the context of a call established using the separated call control protocol.

H.323 annex C (sub-scenarios 1c and 2c) gives the option of using two SVCs, each used unidirectionally, or a single SVC used bidirectionally for RTP for each real-time medium. It encourages the latter. In principle, the same can apply when using B-ISDN separated call and bearer control, but a single bidirectional SVC would be the normal situation. It is assumed below that SVCs are used bidirectionally

both in the H.323 environment and in the native B-ISDN environment. For multi-party operation, considerations may be different.

For each real-time media stream, two SVCs need to be established:

1. For SVC establishment between an H.323 endstation and the gateway, the AESA supplied in the H.245 **OpenLogicalChannelAck** message is used as the destination address. If **OpenLogicalChannel** is sent by the H.323 endstation, this will be the AESA of the gateway. If **OpenLogicalChannel** is sent by the gateway, this will be the AESA of the H.323 endstation. Association of the incoming SVC with the logical channel that has been opened is achieved by conveying the agreed port number in the Q.2931 SETUP message (currently in the B-HLI information element, although this is not entirely appropriate and a better solution may be found).
2. For SVC establishment in the native B-ISDN environment, the AESA supplied in the bearerEstablishmentAddress parameter of the first call control message from the peer CC is used as the destination address. If SVC establishment is from the gateway, this will be the AESA of the next call control entity. If SVC establishment is to the gateway, this will be the gateway's AESA. Association of the incoming SVC with the call is achieved by carrying the call segment ID in the Call association information element.

When H.323 annex C is not used (sub-scenarios 1a, 1b, 2a and 2b), H.323 encourages the use of two unidirectional logical channels, although the ability to open a bidirectional logical channel does exist. Assuming unidirectional logical channels are used in the H.323 environment, these will ideally need to map to SVCs used bidirectionally in the B-ISDN environment. When receiving an **OpenLogicalChannel** message from the H.323 environment, the gateway will probably need to assume that the endpoint in the B-ISDN environment will transmit similar information in the opposite direction, and therefore send a similar **OpenLogicalChannel** in the reverse direction and open an SVC for bidirectional use in the B-ISDN environment. When receiving an SVC establishment from the B-ISDN environment, if the SVC is for bidirectional use the gateway can either:

- open a bidirectional logical channel in the H.323 environment; or
- open a unidirectional logical channel in the H.323 environment and rely on the H.323 endpoint to open a similar logical channel in the reverse direction.

In the latter case, there is the danger that the logical channel in the reverse direction will require capabilities not supported by the already-established SVC, although this could be handled by using SVC modification procedures.

7.7 Addressing

7.7.1 Addressing in H.323

H.323 entities are addressed by transport addresses, which depend on the underlying network type. The following types of transport addresses are currently supported:

- IP (v4 and v6) address plus port number;
- IP source route: a list of IPv4 addresses, a 'strict' or 'loose' indicator, and a port number;
- IPX address;
- NetBIOS address;
- NSAP address;
- Non-standard address: an arbitrary octet string plus an identifier (either an H.221 identifier or an object identifier).

NOTE

In practice IP addresses are the only relevant type since H.323 is usually run over IP networks.

Endpoints (terminals, gateways) may also have one or more alias addresses assigned to them. Alias addresses are resolved to transport addresses by gatekeepers. The use of directory services, either by gatekeepers or directly by endpoints, is outside the scope of H.323 and is a subject of intense study, e.g. in IETF IPTTEL. Alias address types currently supported are as follows.

- *E.164*: implicit format only, i.e. a string of numbers, commas, star and hash characters. Prefixes are frequently used, e.g. as service indicators. The maximum length is 128 octets.
- *H.323 ID*: A string of up to 256 Unicode characters.
- *URL*: Follows the rules for WWW URLs (up to. 512 IA5 characters).
- *Email address*: in RFC 822 format (up to. 512 IA5 characters).
- *Transport address*: All types listed above are allowed.
- *Party number*: An ISDN / PISN number in explicit format, i.e. indicating the applicable numbering plan, E.164 or PNP. The number itself can be of type 'unknown'. NSAP-encoded numbers are not supported by this type.

For the purposes of this report, only alias addresses that represent B-ISDN/B-PISN numbers are relevant. These are: party number, E.164, and perhaps transport addresses of type NSAP. Note that subaddresses are not part of alias addresses.

NOTE

The inclusion of NSAP addresses as alias addresses requires investigation.

7.7.2 Addressing in B-ISDN and B-PISN

DTS/TIPHON-04001 defines naming and addressing requirements for interworking voice service from an IP (H.323) terminal to a PSTN, ISDN or GSM terminal addressed with an E.164 number.

DTS/TIPHON-04002 defines interworking from an E.164 addressed PSTN, ISDN or GSM terminal to an IP terminal.

Interworking of multimedia services between an H.323 IP terminal and a B-ISDN terminal requires support for the addressing formats used in ATM and B-ISDN networks. These addressing formats are the 16-octet E.164 format (as used in the N-ISDN), and the 20-octet ATM End System Addressing Formats (AESA) formats as defined by the ATM Forum¹ and by ITU-T in Recommendation E.191. There are several types of ATM End System Address including the following.

- DCC AESA format: a 20-octet AESA address formatted with an Address and Format Indicator (AFI) value = 39 and containing a Data Country Code assigned to a national authority such as ANSI, BSI or DIN.
- ICD AESA format: a 20-octet AESA address formatted with an Address and Format Indicator (AFI) value = 47 and containing a International Code Designator assigned for use by International data networks or other large organisations.
- E.164 AESA format: a 20-octet AESA address formatted with an Address and Format Indicator (AFI) value = 45 and containing an embedded 16-digit E.164 number whose first significant digit is non-zero.
- E.164 AESA format: a 20-octet AESA address formatted with an Address and Format Indicator (AFI) value = 59 and containing an embedded 16-digit E.164 number whose first significant digit is zero (may be used for B-PISNs).
- Local AESA format: a 20-octet AESA address formatted with an Address and Format Indicator (AFI) value = 49. May be used by a B-PISN for Private Numbering Plans (PNP); a PNP number is embedded as a 16-digit number analogous to an E.164 number.

ITU-T B-ISDN networks (supporting DSS2 and B-ISUP protocols) require mandatory support by the network of the E.164 addressing format at the user access and additional optional support of the ATM End System Addressing Formats. In the case where AESA addressing is used, the B-ISDN network derives an E.164 number from the called party address for routing purposes, and transports the 20-octet AESA format called and calling party addresses across the B-ISDN in accordance with ITU-T

¹ See ATMF98-0144 "Basic Addressing: Current Capabilities", G. Wetzel

Recommendation Q.2726.1 in order to restore addresses at the network egress to the format in which they were presented at the ingress.

ATM Forum networks (supporting UNI 3.1, UNI 4.0 and PNNI 1.0 protocols) require the mandatory support of ATM End System Addressing formats at the UNI, and the optional support of E.164 formatted addresses. Routing within the network is based on E.164 AESA addresses.

B-PISN networks (supporting B-QSIG) require mandatory support of the E.164 addressing format and additional optional support of the ATM End System Addressing Formats. In both cases the meaning of the address is according to ECMA-155 (ISO/IEC 11571).

The extension of TIPHON Phase 1 and Phase 2 work to include the additional requirement to interwork between IP terminals and B-ISDN terminal therefore implies the need to treat AESA formats as a valid naming/numbering scheme.

7.7.3 Address interworking between H.323 and B-ISDN

For interworking of H.323 and B-ISDN/B-PISN address mapping is necessary. A transport address on the H.323 side has to be mapped to an (alias) address recognised in the B-ISDN/B-PISN and vice versa. The relevant types of alias addresses are the ones both networks have in common: E.164 and party number. If only an alias address of another type is available, an additional resolution step is necessary to obtain an alias address that represents a valid B-ISDN/B-PISN address.

The scenario IP network ↔ B-ISDN/B-PISN ↔ IP network and its addressing requirements are described in clause 11.

NOTE

The inclusion of NSAP addresses as alias addresses requires investigation.

NOTE

Further study is required to take into account the work of other bodies on the subject of addressing (e.g., the IETF E.164 Birds of a Feature activity, TIPHON, NA2) and also to assess the impact on addressing of call/bearer separation.

7.8 Message sequences for basic communication establishment

This message sequences shown below are suggestions of how interworking could be achieved, but further investigations may reveal alternatives. Figure 17 shows the conventions used in the subsequent diagrams.

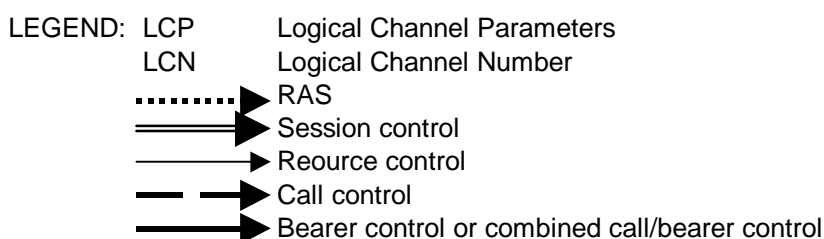

Figure 17 – Conventions used in message sequence diagrams

7.8.1 Scenarios 1a and 1b

Figure 18 shows an example message sequence for scenario 1a or 1b for communication establishment in the direction H.323 to B-ISDN. Within the example are examples of bearer establishment:

- towards the B-ISDN terminal with unidirectional logical channels in the H.323 environment;
- towards the B-ISDN terminal with a bidirectional logical channel in the H323 environment;
- from the B-ISDN terminal with a bidirectional logical channel in the H.323 environment.

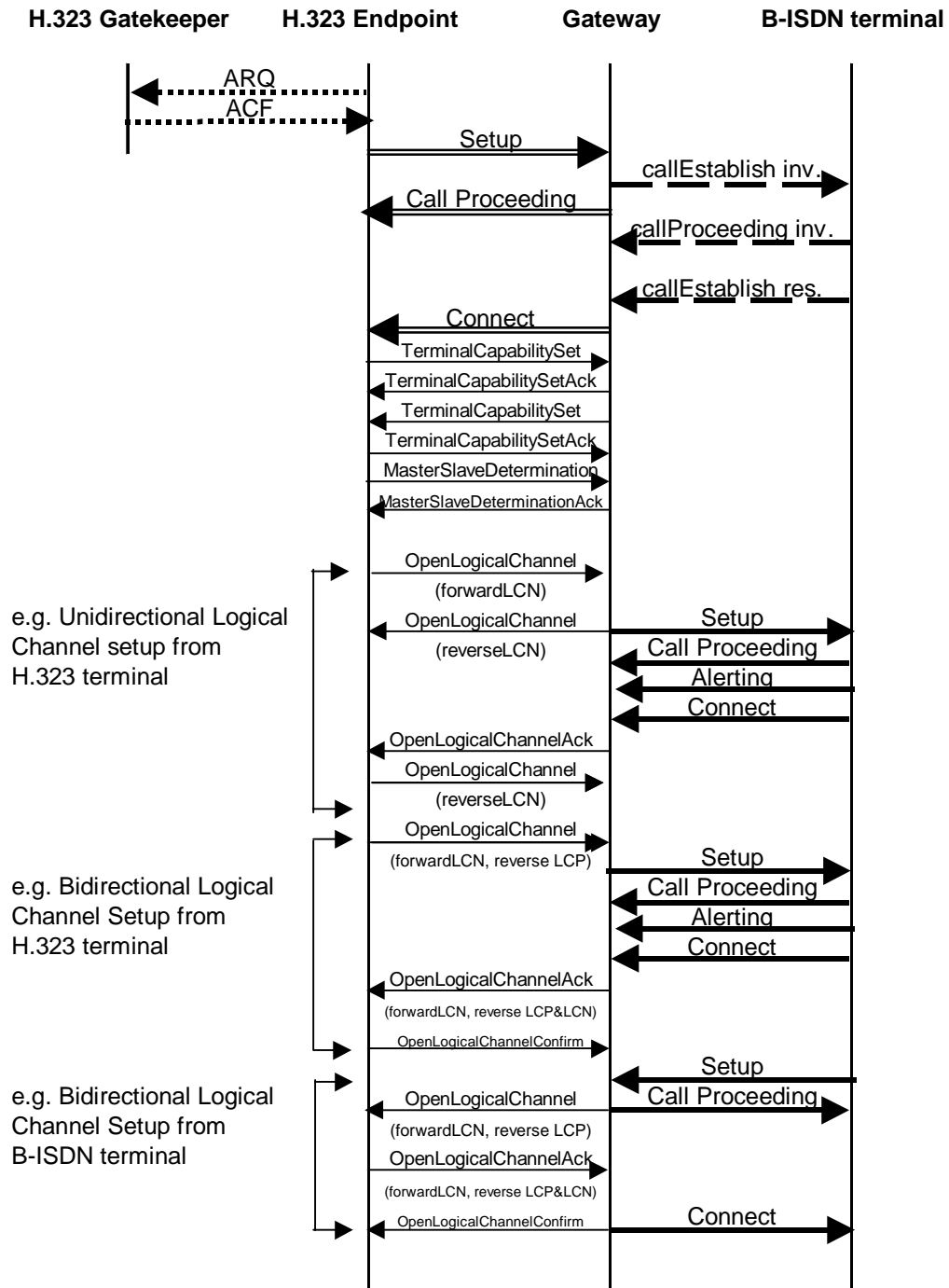

Figure 18 – Communication establishment from H.323 endpoint to B-ISDN separated call/bearer control environment in accordance with scenarios 1a and 1b

Figure 19 shows communication establishment in the reverse direction. Bearer establishment is not shown, as both directions of bearer establishment are shown in figure 18.

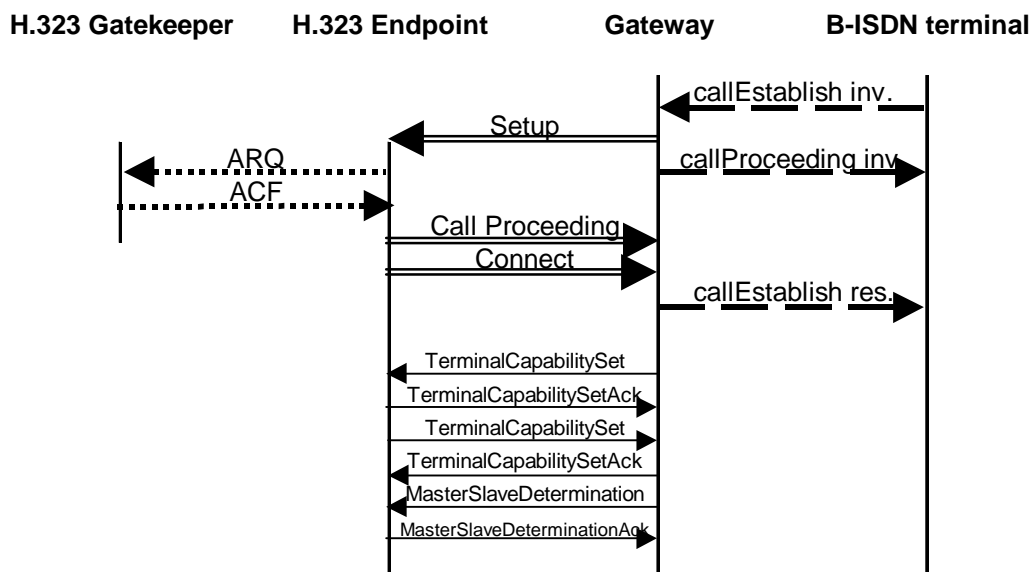

Figure 19 – Communication establishment from B-ISDN separated call/bearer control environment to H.323 endpoint in accordance with scenario 1

7.8.2 Scenario 1c

Figure 20 shows an example message sequence for scenario 1c for communication establishment in the direction H.323 to B-ISDN. Within the example are examples of bearer establishment:

- towards the B-ISDN terminal with a bidirectional logical channel and a single SVC in the H323 environment;
- from the B-ISDN terminal with a bidirectional logical channel and a single SVC in the H.323 environment.

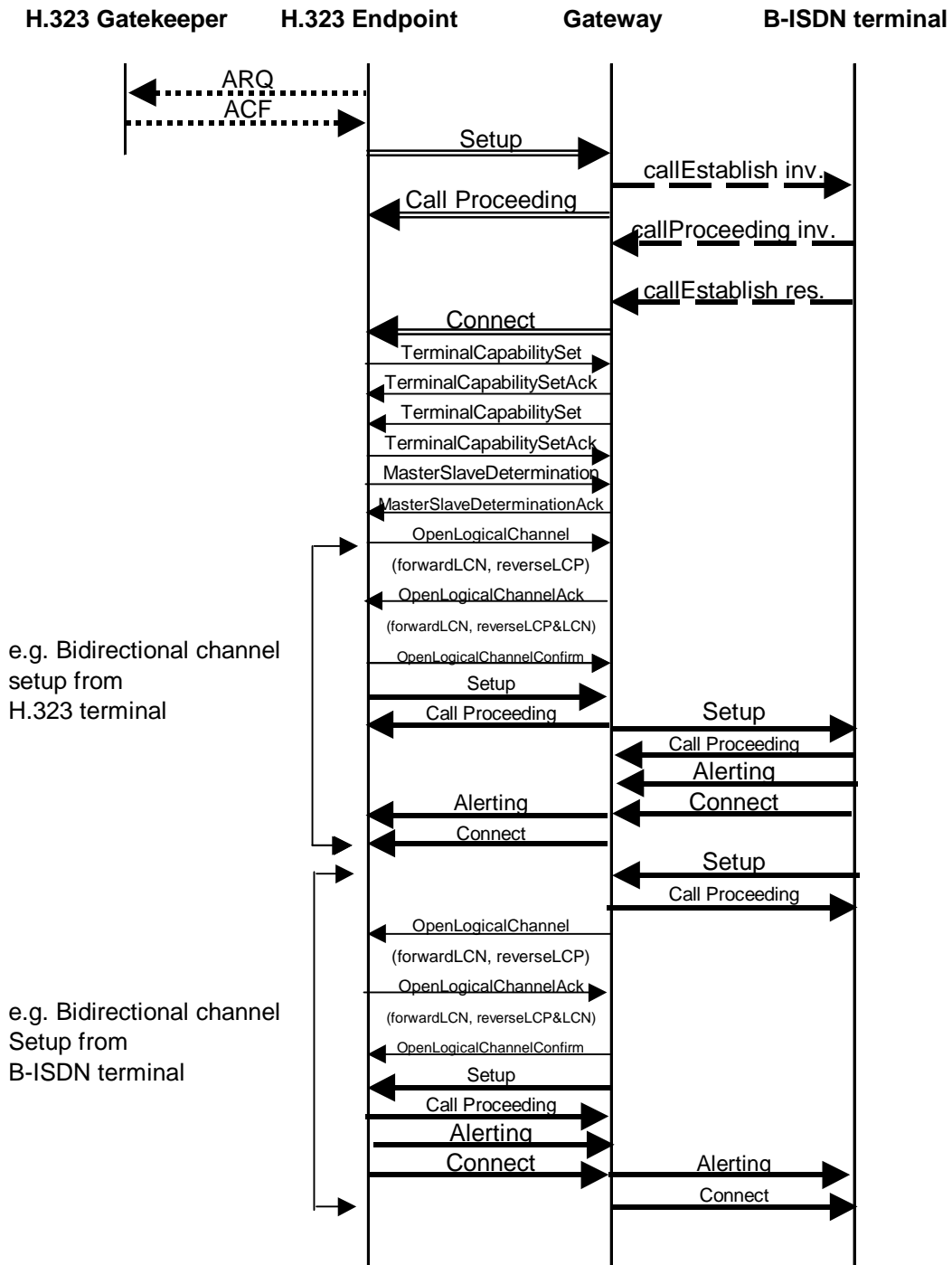

Figure 20 – Communication establishment from H.323 endpoint to B-ISDN separated call/bearer control environment in accordance with scenario 1c

Communication establishment in the reverse direction is as shown in figure 19.

7.8.3 Scenarios 2a and 2b

Figure 21 shows an example message sequence for scenario 2a or 2b for communication establishment in the direction H.323 to B-ISDN. Within the example are examples of bearer establishment:

- towards the B-ISDN terminal with unidirectional logical channels in the H.323 environment;
- towards the B-ISDN terminal with a bidirectional logical channel in the H.323 environment;
- from the B-ISDN terminal with a bidirectional logical channel in the H.323 environment.

The opening of logical channels within the B-ISDN environment is not shown and requires further study.

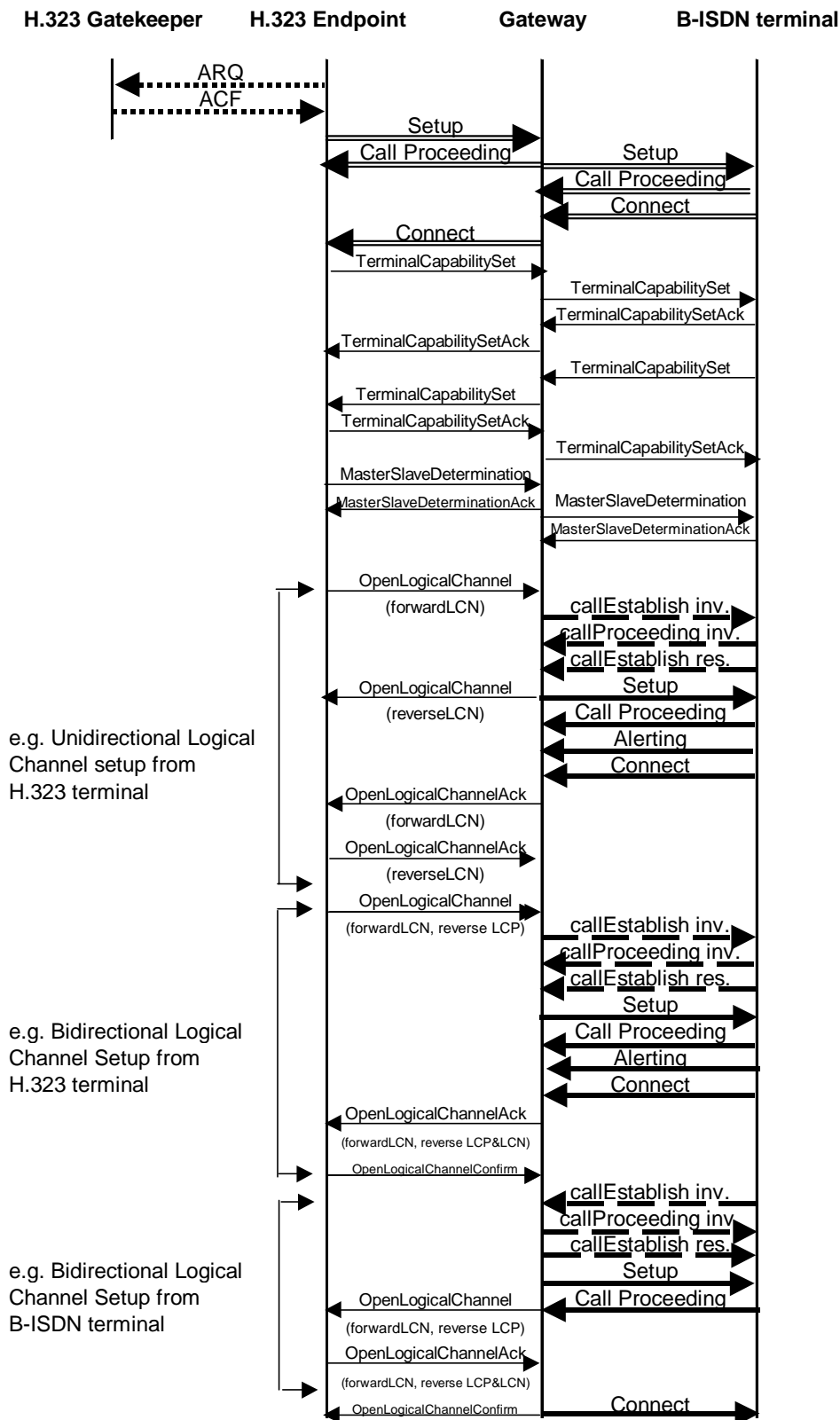

Figure 21 – Communication establishment from H.323 endpoint to B-ISDN separated call/bearer control environment in accordance with scenarios 2a and 2b

Figure 22 shows communication establishment in the reverse direction. Bearer establishment is not shown, as both directions of bearer establishment are shown in figure 21.

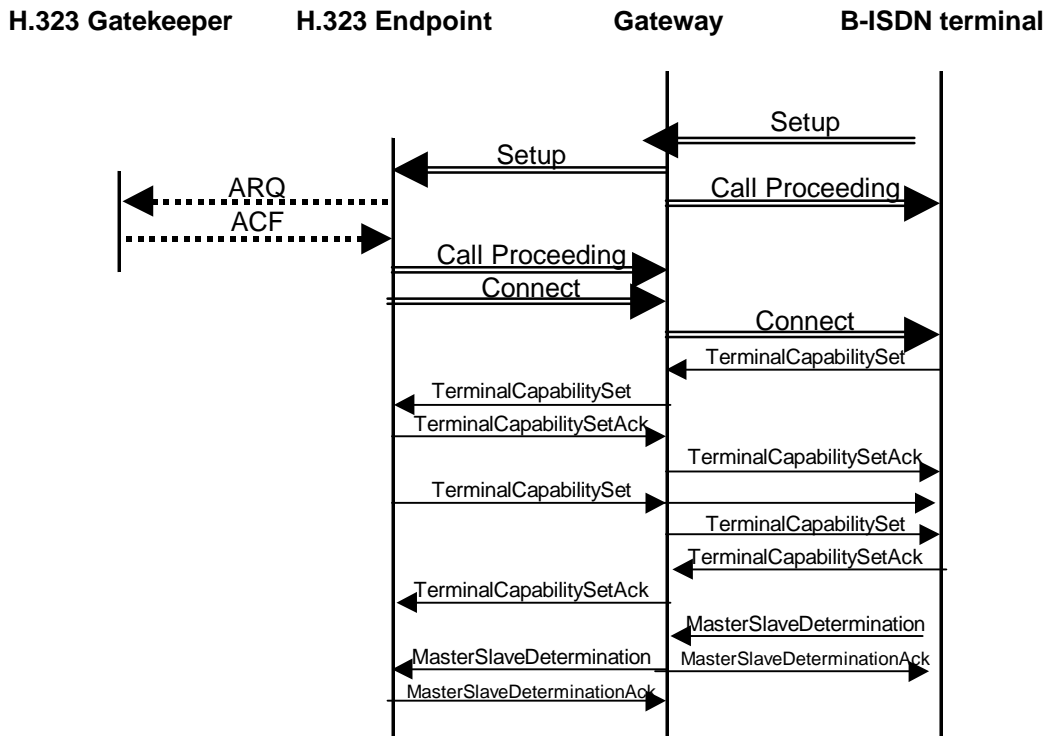

Figure 22 – Communication establishment from B-ISDN separated call/bearer control environment to H.323 endpoint in accordance with scenario 2

7.8.4 Scenario 2c

Figure 23 shows an example message sequence for scenario 2c for communication establishment in the direction H.323 to B-ISDN. Within the example are examples of bearer establishment:

- towards the B-ISDN terminal with a bidirectional logical channel and a single SVC in the H323 environment;
- from the B-ISDN terminal with a bidirectional logical channel and a single SVC in the H.323 environment.

The opening of logical channels within the B-ISDN environment is not shown and requires further study.

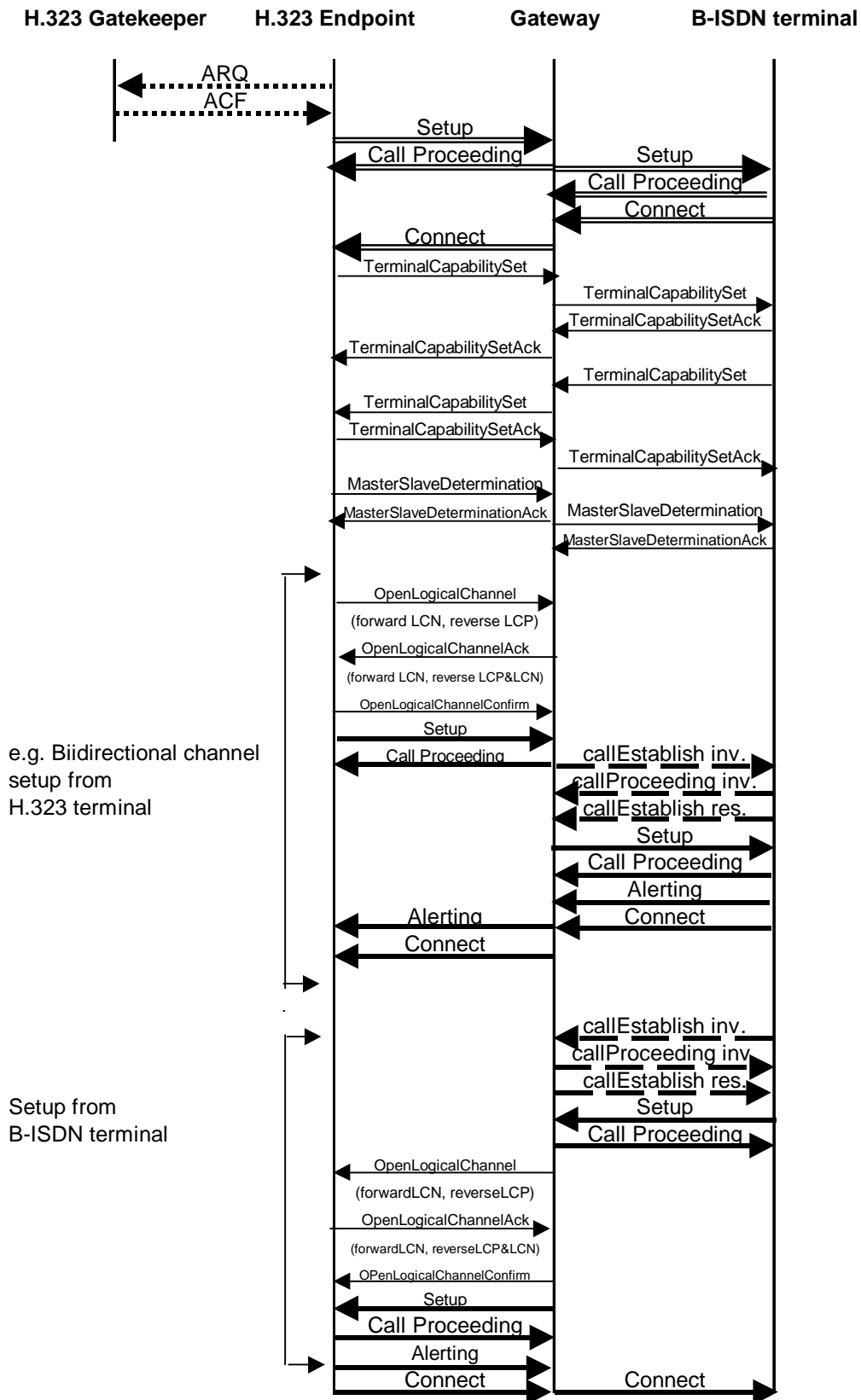

Figure 23 – Communication establishment from H.323 endpoint to B-ISDN separated call/bearer control environment in accordance with scenarios 2c

Communication establishment in the reverse direction as shown in figure 22.

7.8.5 Scenario 3c

Figure 24 shows an example message sequence for scenario 3c for communication establishment in the direction H.323 to B-ISDN. Within the example are examples of bearer establishment:

- towards the B-ISDN terminal with a bidirectional logical channel;
- from the B-ISDN terminal with a bidirectional logical channel.

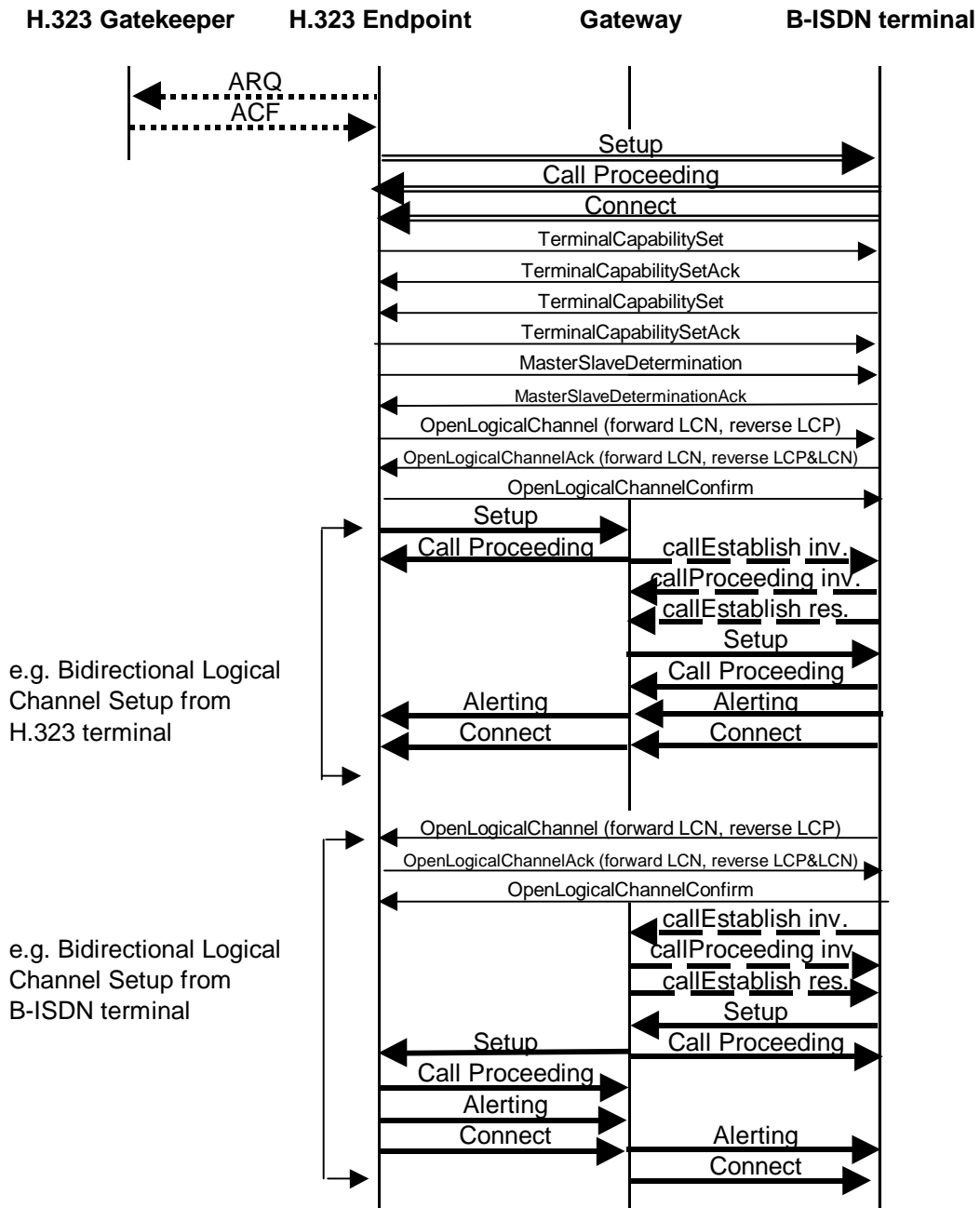

Figure 24 – Communication establishment from H.323 endpoint to B-ISDN separated call/bearer control environment in accordance with scenario 3c

Figure 25 shows communication establishment in the reverse direction. Bearer establishment is not shown, as both directions of bearer establishment are shown in figure 24.

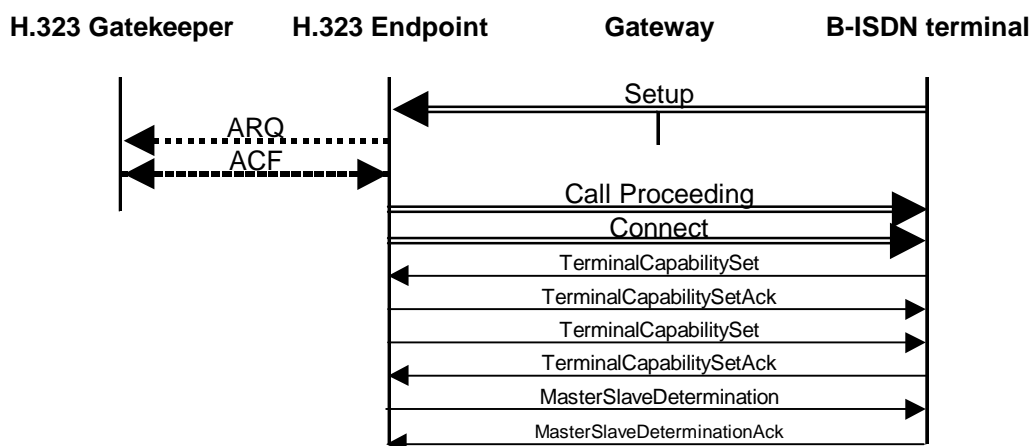

Figure 25 – Communication establishment from B-ISDN separated call/bearer control environment to H.323 endpoint in accordance with scenario 3

7.9 Generic Functional Protocol

A generic functional protocol is defined to allow the carriage of ROSE APDUs flexibly between locations where processing of the contents of the APDUs is required, bypassing those locations where processing of the contents of the ROSE APDUs is not required.

In the H.323 environment, many supplementary services are users of the generic functional protocol, as defined in ITU-T Recommendation H.450.1.

In the separated B-ISDN environment the generic functional protocol as defined in B-QSIG can apply. An enhanced generic functional protocol is being worked on which can apply to B-ISUP and UNI as well as to the B-QSIG protocol.

This generic functional protocol can be used for carrying the call control and pre-negotiation protocols as well as individual supplementary services.

Due to the varying nature of the environments in which they exist, the generic functional protocols of the H.323 environment and the B-ISDN environment are not identical. These different generic functional protocols may be defined as follows:

- B-ISDN environment: ITU-T recommendation Q.2932.1; draft ITU-T recommendation Q.2932.2, draft ITU-T recommendation Q.gft and ECMA-254.
- H.323 environment: ITU-T recommendation H.450.1.

Further study is required as to whether supplementary services can operate transparently between the two environments using an enhanced GFT-Control, as currently being progressed in ITU-T Study Group 11 and ETSI SPS5 WG5, taking into account issues such as the different entity types in the two environments, Network Facility Extension addressing values and encoding rules.

7.10 Supplementary services

7.10.1 Introduction

H.323 provides for a number of supplementary services running within what is a session control protocol. Standardised supplementary services are defined in the ITU-T Recommendation H.450 series. These are supported by a generic functional protocol defined in ITU-T Recommendation H.450.1. Both the protocol for the supplementary services, and the generic functional protocol, are based on the narrowband ISDN QSIG protocols.

The separated call control protocol provides also for the support of supplementary services, but in this case they are running within a call control protocol. Standardised supplementary services have been

discussed, but none have yet been documented. The generic functional protocol for supporting individual supplementary services is discussed in 7.9.

Interworking for supplementary services can take place at the H.323 gateway under the following circumstances:

- a) the supplementary service in the H.323 environment, and the supplementary service in the B-ISDN environment, have related and compatible service descriptions; and
- b) the supplementary service in the H.323 environment, and the supplementary service in the B-ISDN environment, have protocols that have similar and compatible information flows and information flow contents; and
- c) the gateway uses an interworking scenario that provides for interworking between the contents of the session control level of the H.323 environment, and the call control level of the B-ISDN environment. These scenarios are those using scenario 1 and possible those of scenario 2.

7.10.2 Supplementary services in scenario 1

In this scenario, it is assumed that the session level supplementary service provided in the H.323 environment is interworked at the H.323 gateway with an equivalent call control level supplementary service provided in the B-ISDN environment. However, no call control level supplementary services have been specified to date.

7.10.3 Supplementary services in scenario 2

For scenario 2, interworking does take place at the session and resource level, however there are variations between what is envisaged to be a B-ISDN supplementary service environment, and what exists in the H.323 environment, in terms of the provided and expected service description.

Two possible means of extending the supplementary service could be provided.

- a) The session level supplementary service provided in the H.323 environment is interworked at the H.323 gateway with an equivalent call control level supplementary service provided in the B-ISDN environment. However, no call control level supplementary services have been specified to date.
- b) The session level supplementary service provided in the H.323 environment is interworked at the H.323 gateway with an equivalent session level supplementary service provided in the B-ISDN environment. This assumes that a separate session level protocol is provided in the B-ISDN environment.

7.10.4 Supplementary services in scenario 3

Scenario 3 provides for no interworking of the session control level in the H.323 environment and the call control level in the B-ISDN environment at the H.323 gateway, and therefore any supplementary services cannot be interworked at this gateway; the protocol is transmitted clear to the end terminal.

This absolves the B-ISDN from any responsibility for the supplementary service, but also precludes the B-ISDN from providing the network capabilities that are essential for the support of supplementary services, even when intelligent terminals exist. These capabilities are:

- the protection of one user from another user, i.e. where one user supplies information that is necessary for the operation of a supplementary service, but does not want that information released to another user also involved in the operation of the supplementary service;
- the arbitration between multiple users, where such arbitration would otherwise have to take place between multiple peer entities in the individual terminals, rather than in a centralised controller / administrator;
- the handling of situations when the terminal is absent through being switched off or unplugged.

NOTE

H.323 supplementary services, as specified in the ITU-T Recommendation H.450 series, already suffer from the above identified disadvantages. For example, the H.323 service description for the diversion services, in a similar form to that specified for the equivalent ISDN service descriptions, indicate that the served (forwarding) user has the right to preclude information relating to the forwarded-to address,

etc., from being passed to the calling user. Because there is no centralised routing entity in H.323, in the protocol defined for this supplementary service, this information is passed to the terminal of the calling user in order to reroute the session to the forwarded-to address. This therefore assumes that the calling (human) user does not have access to information within the terminal of the calling user. For most PCs and many users, this is an invalid assumption, and one can expect many freeware and shareware applications being circulated that reveal this information when it is received, even if the original H.323 application does not.

However, any of these situations can be dealt with by a gatekeeper in one of the networks performing functionality that otherwise would be left to the endstation.

7.10.5 Areas for further work

Further study is needed in the following areas:

- whether, despite the common QSIG basis, H.323 puts a different complexion on requirements for supplementary services;
- the application of supplementary services to the separated call and bearer control environment;
- identification of candidate supplementary services and how they would interwork.

7.11 Conferencing

Further study is required.

7.12 Impact of T.120

Further study is required.

8 H.323 interworking via a gateway with B-ISDN combined call/bearer control

The ability to interwork between H.323 and B-ISDN combined call/bearer control would enable the following possibilities:

- a) use of B-ISDN combined call/bearer control in the “core network” but supporting H.323 endstations;
- b) interworking between H.323 endstations and native ATM endstations employing B-ISDN combined call/bearer control;

For possibility a), the “core network” could, for example, be the entire B-ISDN environment (public and private B-ISDNs) or just the public B-ISDN environment (thereby using H.323 within private networks).

8.1 Scenarios

In principle, the three scenarios of 7.1 are applicable also to interworking with B-ISDN combined call/bearer control.

With scenario 1 (no separate session and/or resource control protocol in the B-ISDN) and without B-ISDN separated call and bearer control, there are two ways in which H.323 can interwork with B-ISDN:

1. Each H.323 medium maps onto a single B-ISDN call/connection. No multiplexing structure is required within the B-ISDN connection. This scenario is only appropriate when there is a single medium (e.g. voice) and therefore only a single B-ISDN call/connection. This is because:
 - a) there is no standardized means of co-ordinating multiple bearers arriving at a destination point within a B-ISDN (as would be the case with separated call and bearer control or with a separate resource control protocol);
 - b) it is not apparent how to bring different calls/bearers established from B-ISDN to H.323 together at the interworking point;
 - c) the network has a lack of knowledge of any associations between the calls/bearers, thereby preventing consistent treatment in the context of supplementary services such as call diversion, call transfer and conference;
 - d) it is not apparent how to achieve H.245 functionality.

2. Two or more H.323 media are mapped onto a single B-ISDN call/connection using an appropriate multiplexing structure within the ATM connection, e.g., in accordance with H.310 or H.321. Interworking of the H.323 media streams and the B-ISDN (H.310/H.321) connection is required to be performed in a standardized manner conforming to the appropriate H.series interworking recommendation.

NOTE

Within the multiplexed structure, there is generally a form of resource control protocol, and therefore this solution should perhaps be considered part of scenario 2.

Therefore scenario 1 (figure 26) is assumed to be limited to single medium communications. The H.323 session and resource control protocols are terminated at the interworking unit. Because there is no session or resource control protocol in the B-ISDN environment, the gateway may need to provide mapping between session and/or resource control protocol elements in the H.323 environment and combined call/bearer control protocol elements in the B-ISDN environment.

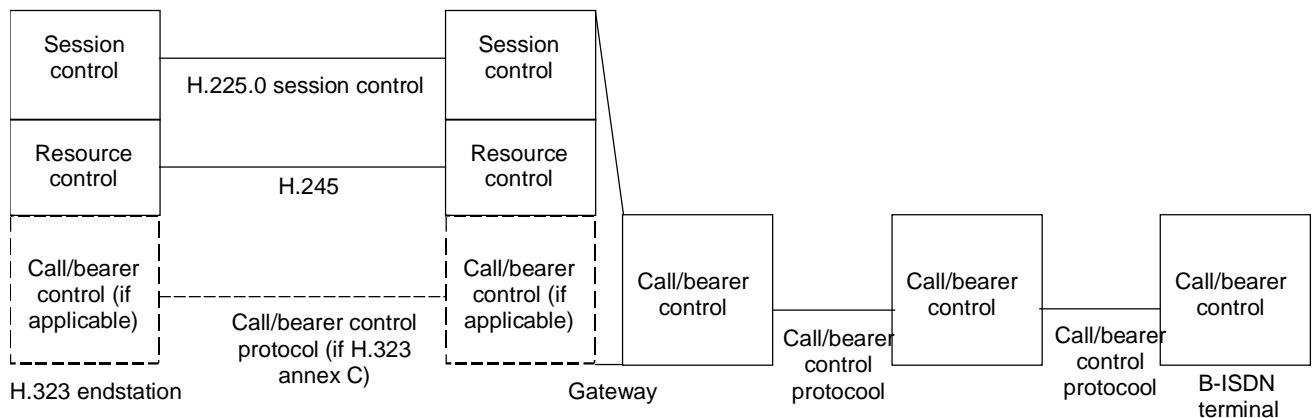

Figure 26 – Interworking with a combined call/bearer control environment - scenario 1

With scenario 2 (figure 27), session and resource control protocols in the two environments can be the same or different, but in either case the gateway terminates these protocols and provides mapping between the two environments. Because the gateway is involved in session and resource control, these can impose control on call/bearer control at the gateway.

With a resource control protocol to perform the necessary binding, multiple call/bearer instances can be used in the B-ISDN environment, and therefore multiple media can be used without the need for multiplexing into a single call/bearer.

The existing call control protocol could easily be adapted to provide a B-ISDN session or resource control protocol, by defining new object classes. Alternatively the H.323 session and/or resource control protocols could be re-used in the B-ISDN environment. Even if protocols are the same in the two environments, with this scenario the protocols are terminated at the gateway.

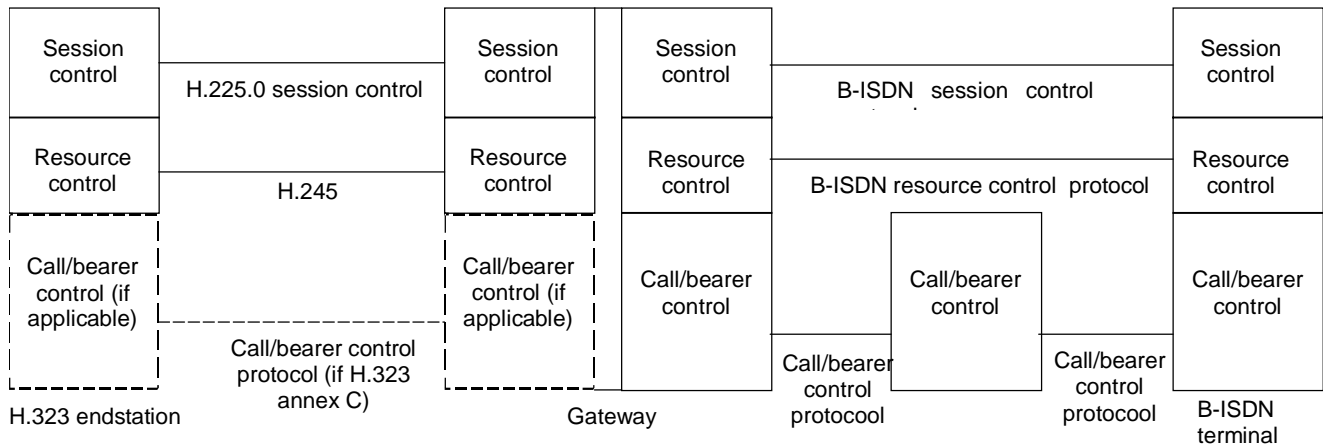

Figure 27 – Interworking with a combined call/bearer control environment - scenario 2

With scenario 3 (figure 28), the gateway is not involved with session and resource control protocols, which pass transparently between the two environments as user plane information. The H.323 session and resource control protocols (H.225.0 session control and H.245) are assumed to be used.

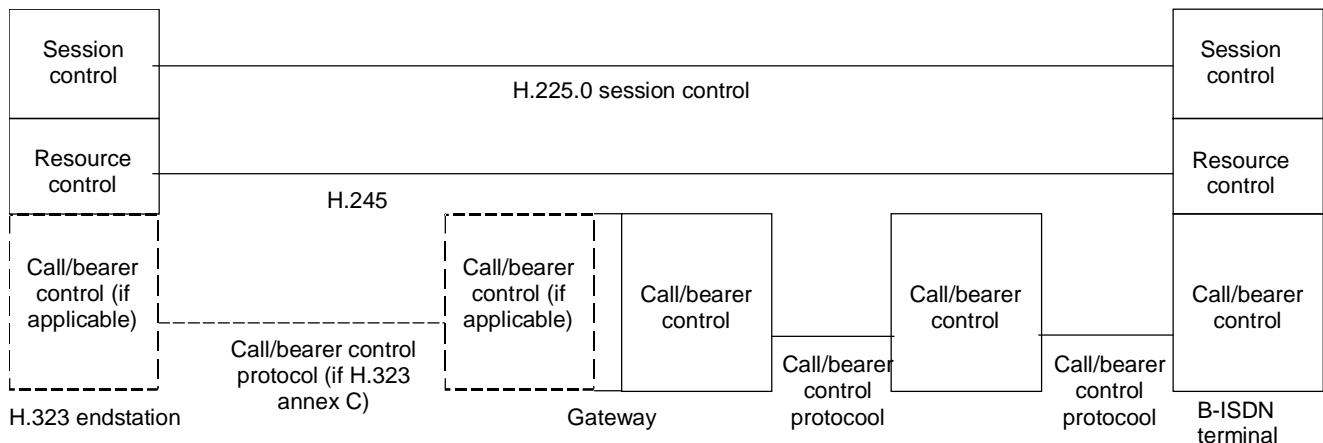

Figure 28 – Interworking with a combined call/bearer control environment - scenario 3

This scenario requires each call in the H.323 environment to map onto a separate instance of the combined call/bearer control protocol in the B-ISDN environment, since there is no resource control involvement at the gateway to bind calls together.

The theoretical alternative of an end-to-end session control protocol but resource control terminated at the gateway does not seem to make sense.

The sub-scenarios identified in 7.1 are also applicable here.

8.2 Protocol interworking architecture

8.2.1 Scenario 1

8.2.1.1 Sub-scenario 1a – null session/resource control in B-ISDN – LAN-based H.323 environment

The model for protocol interworking according to scenario 1a is shown in figure 29. Compared with figure 10, the model for the corresponding sub-scenario when separated call and bearer control are used in the B-ISDN, differences are confined to the right hand side of the figure (ATM network).

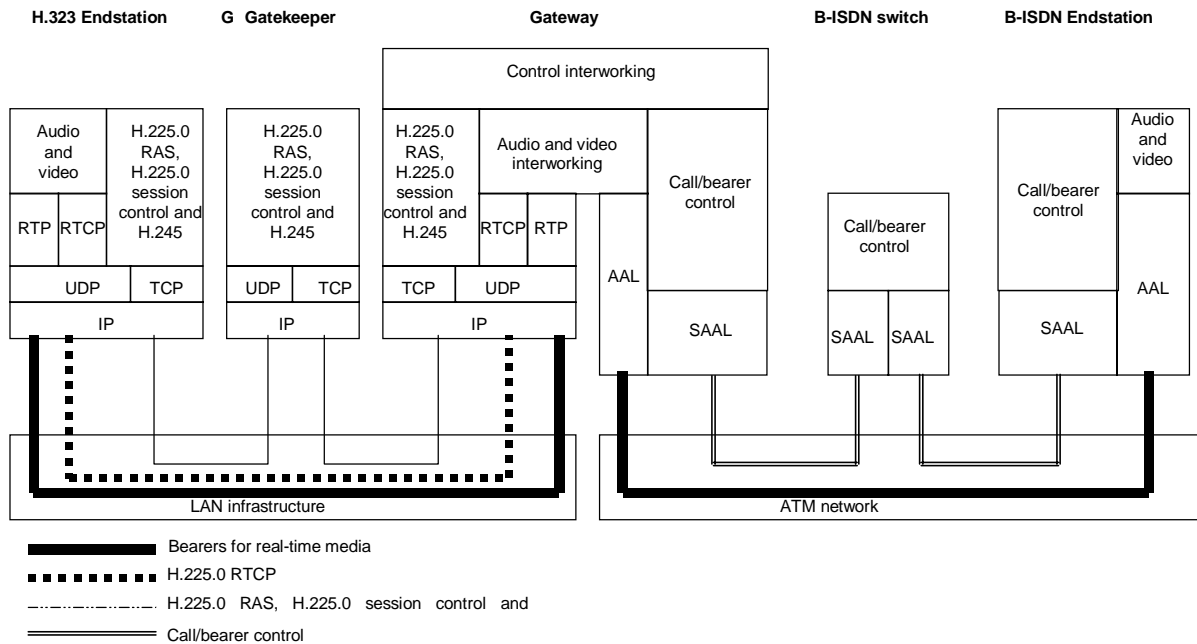

Figure 29 – General model for interworking between H.323 and B-ISDN combined call/bearer control according to scenario 1a

8.2.1.2 Sub-scenario 1b – null session/resource control in B-ISDN – IP-over-ATM-based H.323 environment without H.323 annex C

The model for protocol interworking according to scenario 1b is as shown in figure 11 but with modifications to the right hand side as in figure 29.

8.2.1.3 Sub-scenario 1c – null session/resource control in B-ISDN – use of H.323 annex C in H.323 environment

The model for protocol interworking according to scenario 1c is as shown in figure 12 but with modifications to the right hand side as in figure 29. Considerations in 7.2.1.3 concerning RTP, UDP and IP in the SVC user plane apply also to the combined call/bearer control case.

8.2.2 Scenario 2

To an H.323 endstation, the totality of the interworking functions (control interworking and media interworking) appears as an H.323 gateway. All bearers are constrained to pass through the same gateway as session and resource control.

8.2.2.1 Sub-scenario 2a – each environment operates own session/resource control protocols – LAN-based H.323 environment

The model for protocol interworking according to scenario 2a is shown in figure 30. Compared with figure 13, the model for the corresponding sub-scenario when separated call and bearer control are used in the B-ISDN, differences are confined to the right hand side of the figure.

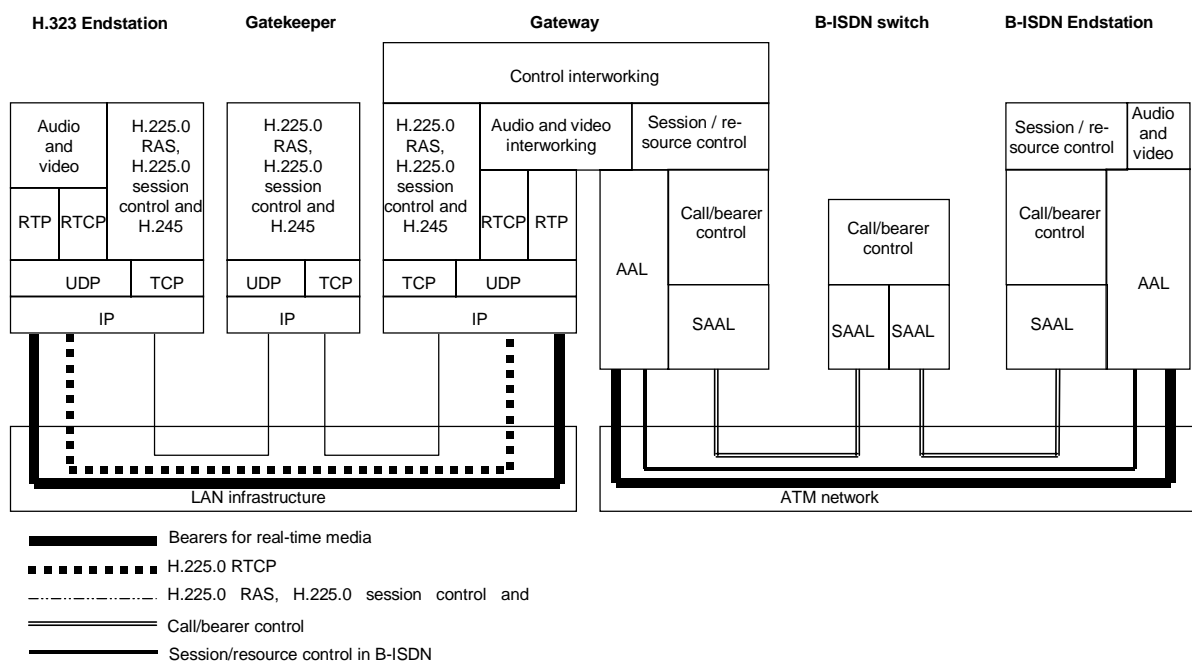

Figure 30 – General model for interworking between H.323 and B-ISDN combined call/bearer control according to scenario 2a

8.2.2.2 Sub-scenario 2b– each environment operates own session/resource control protocols – IP-over-ATM-based H.323 environment without H.323 annex C

The model for protocol interworking according to scenario 2b is as shown in figure 14 but with modifications to the right hand side as in figure 30.

8.2.2.3 Sub-scenario 2c– each environment operates own session/resource control protocols – use of H.323 annex C in H.323 environment

The model for protocol interworking according to scenario 1c is as shown in figure 15 but with modifications to the right hand side as in figure 30. Considerations regarding the presence of RTP in the SVC user plane and the interworking of real-time media streams are as for scenario 1c.

8.2.3 Scenario 3

As for the separated case (7.2.3), the only sub-scenario that can apply is 3c.

8.2.3.1 Sub-scenario 3c – end-to-end session/resource control protocols – use of H.323 annex C in H.323 environment

The model for protocol interworking according to scenario 3c with RTP, UDP and IP all carried end-to-end (perhaps compressed) in the real-time media stream SVCs is shown in figure 31. Also RTCP is assumed to be carried end-to-end. No assumption is made about the number and type of SVCs to be used for carrying H.225.0 session control, H.245 resource control and RTCP within the native ATM environment.

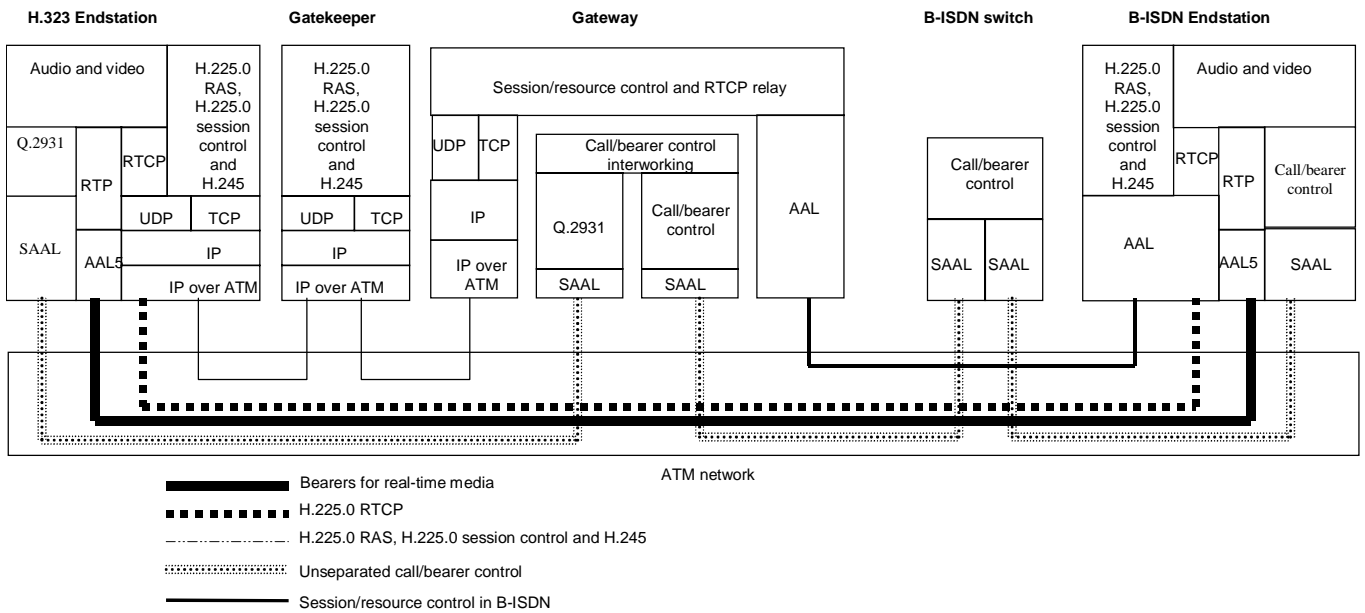

Figure 31 – General model for interworking between H.323 (annex C) and B-ISDN combined call/bearer control according to scenario 3c

NOTE

The use of gatekeepers and the RAS protocol in the B-ISDN environment requires further study.

8.3 Session control in B-ISDN environment

Considerations are as in 7.3 for the separated case.

8.4 Resource control in B-ISDN environment

Considerations are as in 7.4 for the separated case.

8.5 Call/bearer establishment

For scenario 1, there is a need for the gateway to map between the session control protocol used in the H.323 environment and B-ISDN combined call/bearer control. The H.225.0 session control (Q.931) Bearer capability information element (BC) should map on to the Narrowband bearer capability (N-BC) information element in the B-ISDN call/bearer control protocol, i.e., a narrowband service is requested over B-ISDN.

For scenario 2, call/bearer establishment occurs independently in the two environments, each under the control of the respective resource control protocol. For the H.323 environment, call establishment applies only to sub-scenario 2c and uses combined call/bearer control in accordance with H.323 annex C.

When H.323 annex C is used in the H.323 environment (sub-scenarios 1c and 2c), a single SVC used bidirectionally would normally be used, and this would map well onto a single SVC used bidirectionally in the B-ISDN environment. When annex C is not used in the H.323 environment, considerations concerning the mapping of logical channels onto SVCs are similar to the separated bearer control case in 7.6.

For scenario 3 (sub-scenario 3c), call/bearer establishment is end-to-end in accordance with H.323 annex C.

8.6 Addressing

Considerations are as in 7.7 for the separated case.

8.7 Message sequences for basic communication establishment

This message sequences shown below are suggestions of how interworking could be achieved, but further investigations may reveal alternatives. Conventions are as in 7.8.

8.7.1 Scenarios 1a and 1b

Figure 32 shows an example message sequence for scenario 1a or 1b for communication establishment in the direction H.323 to B-ISDN using a pair of unidirectional logical channels in the H.323 environment. It is assumed that the H.225.0 session control SETUP message contains sufficient information for the gateway to:

- send a B-ISDN call/bearer control SETUP message (e.g., using contents of received BC information element in transmitted N-BC information element); and
- deduce the required terminal capabilities of the B-ISDN terminal, in order to engage in terminal capability exchange with the H.323 endpoint and open a pair of logical channels.

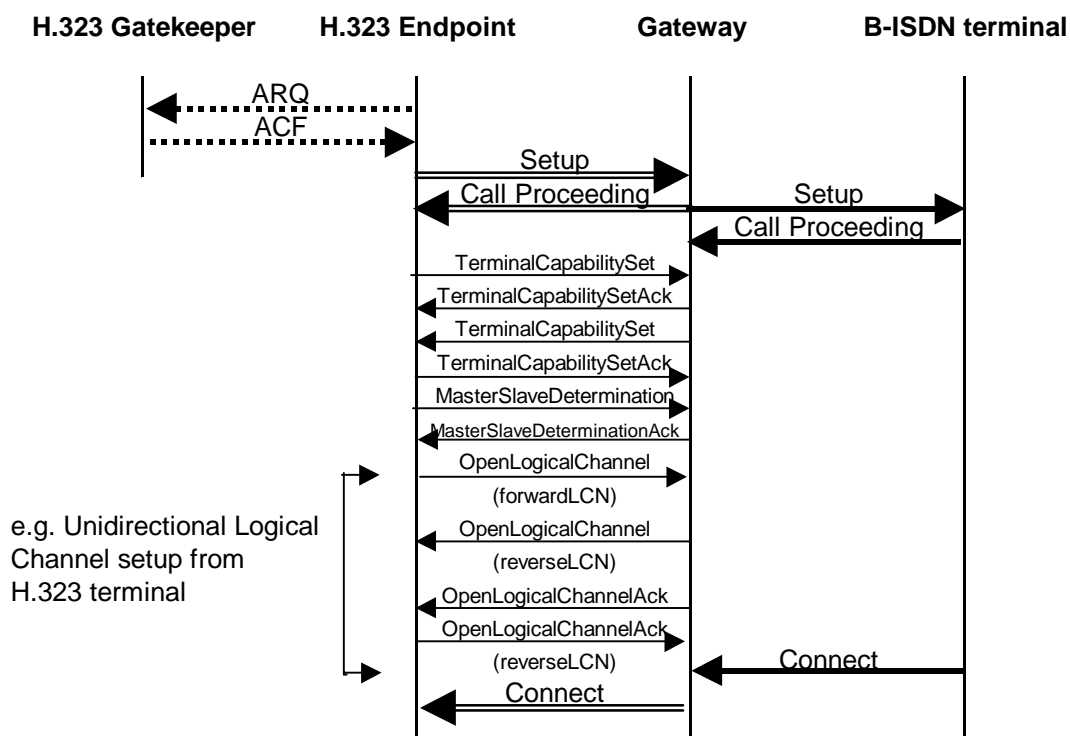

Figure 32 – Communication establishment from H.323 endpoint to B-ISDN separated call/bearer control environment in accordance with scenarios 1a and 1b

Figure 33 shows communication establishment in the reverse direction.

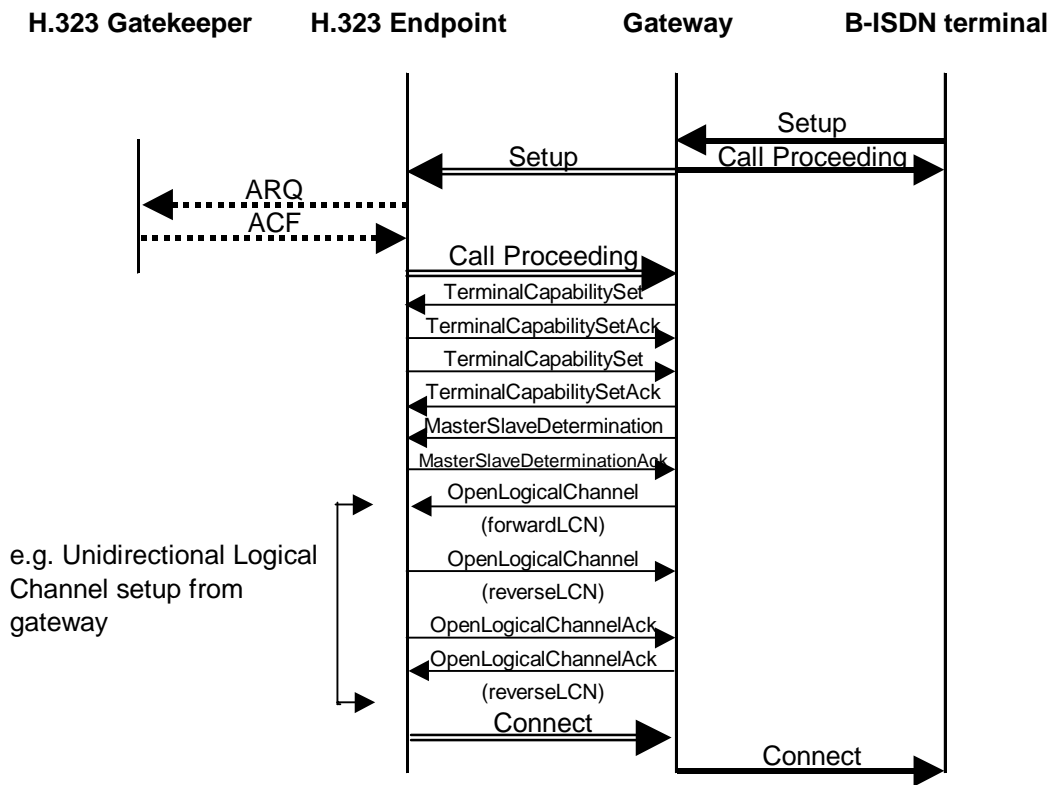

Figure 33 – Communication establishment from B-ISDN separated call/bearer control environment to H.323 endpoint in accordance with scenario 1

8.7.2 Scenario 1c

Figure 34 shows an example message sequence for scenario 1c for communication establishment in the direction H.323 to B-ISDN using a single bidirectional logical channel and a single SVC in the H.323 environment.

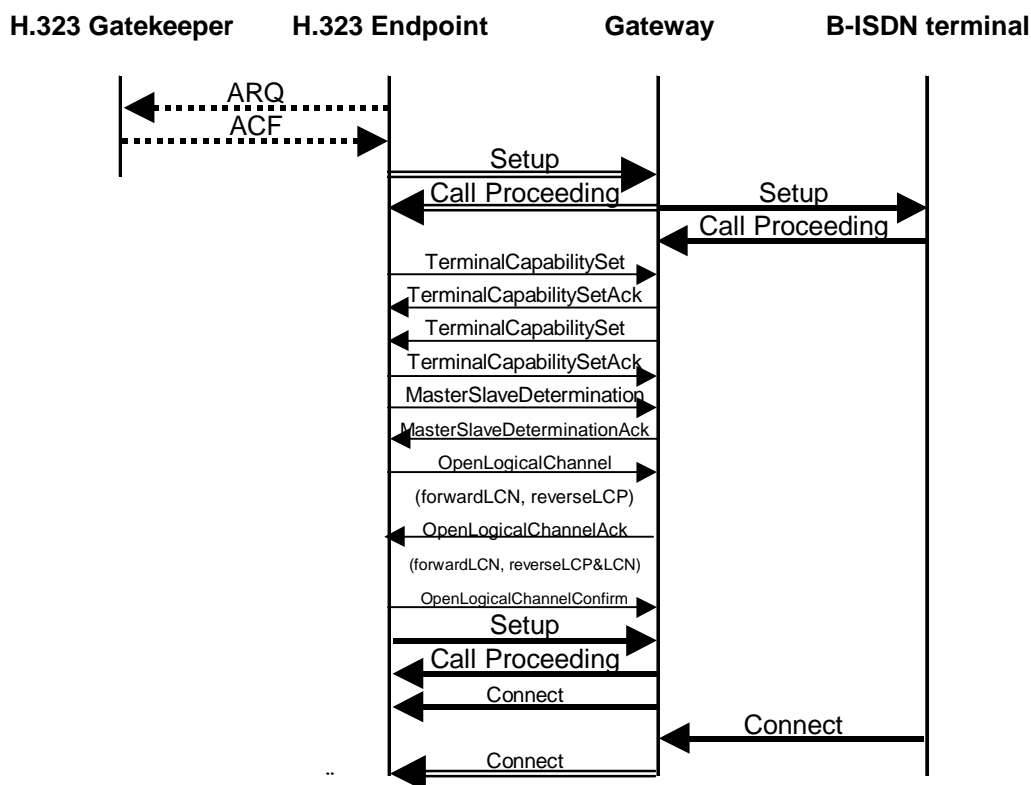

Figure 34 – Communication establishment from H.323 endpoint to B-ISDN separated call/bearer control environment in accordance with scenario 1c

Communication establishment in the reverse direction is as shown in figure 33, modified with bidirectional logical channel opening and SVC establishment in the H.323 environment similar (but in the opposite direction) to that shown in figure 34.

8.7.3 Scenarios 2a and 2b

Figure 35 shows an example message sequence for scenario 2a or 2b for communication establishment in the direction H.323 to B-ISDN. Within the example are examples of bearer establishment:

- towards the B-ISDN terminal with unidirectional logical channels in the H.323 environment;
- towards the B-ISDN terminal with a bidirectional logical channel in the H.323 environment;
- from the B-ISDN terminal with a bidirectional logical channel in the H.323 environment.

The opening of logical channels within the B-ISDN environment is not shown and requires further study.

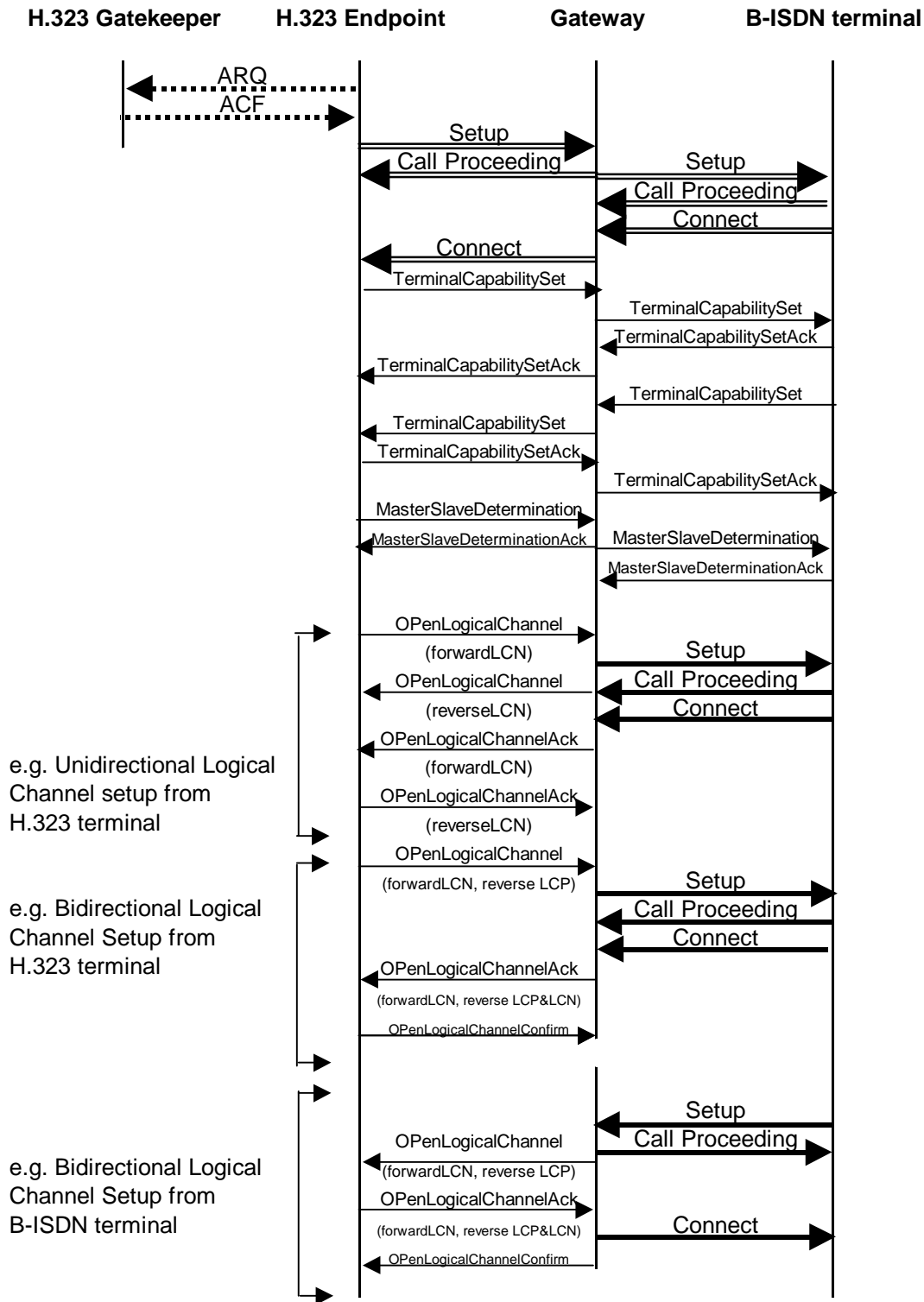

Figure 35 – Communication establishment from H.323 endpoint to B-ISDN separated call/bearer control environment in accordance with scenarios 2a and 2b

Figure 36 shows communication establishment in the reverse direction. Bearer establishment is not shown, as both directions of bearer establishment are shown in figure 35.

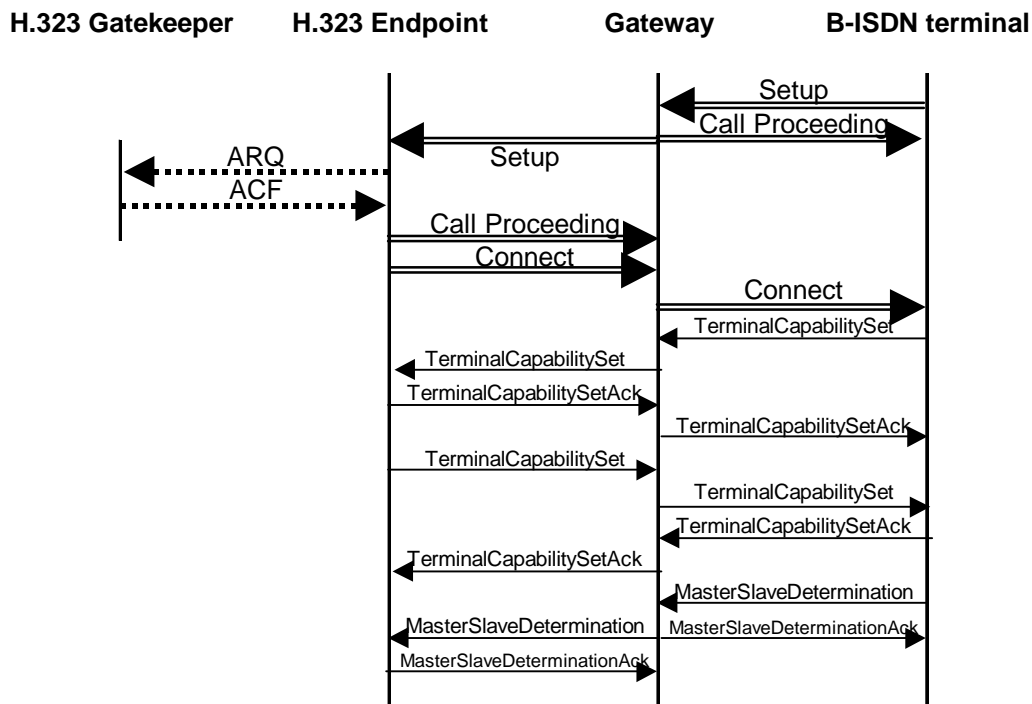

Figure 36 – Communication establishment from B-ISDN separated call/bearer control environment to H.323 endpoint in accordance with scenario 2

8.7.4 Scenario 2c

Figure 37 shows an example message sequence for scenario 2c for communication establishment in the direction H.323 to B-ISDN. Within the example are examples of bearer establishment:

- towards the B-ISDN terminal with a bidirectional logical channel and a single SVC in the H323 environment;
- from the B-ISDN terminal with a bidirectional logical channel and a single SVC in the H.323 environment.

The opening of logical channels within the B-ISDN environment is not shown and requires further study.

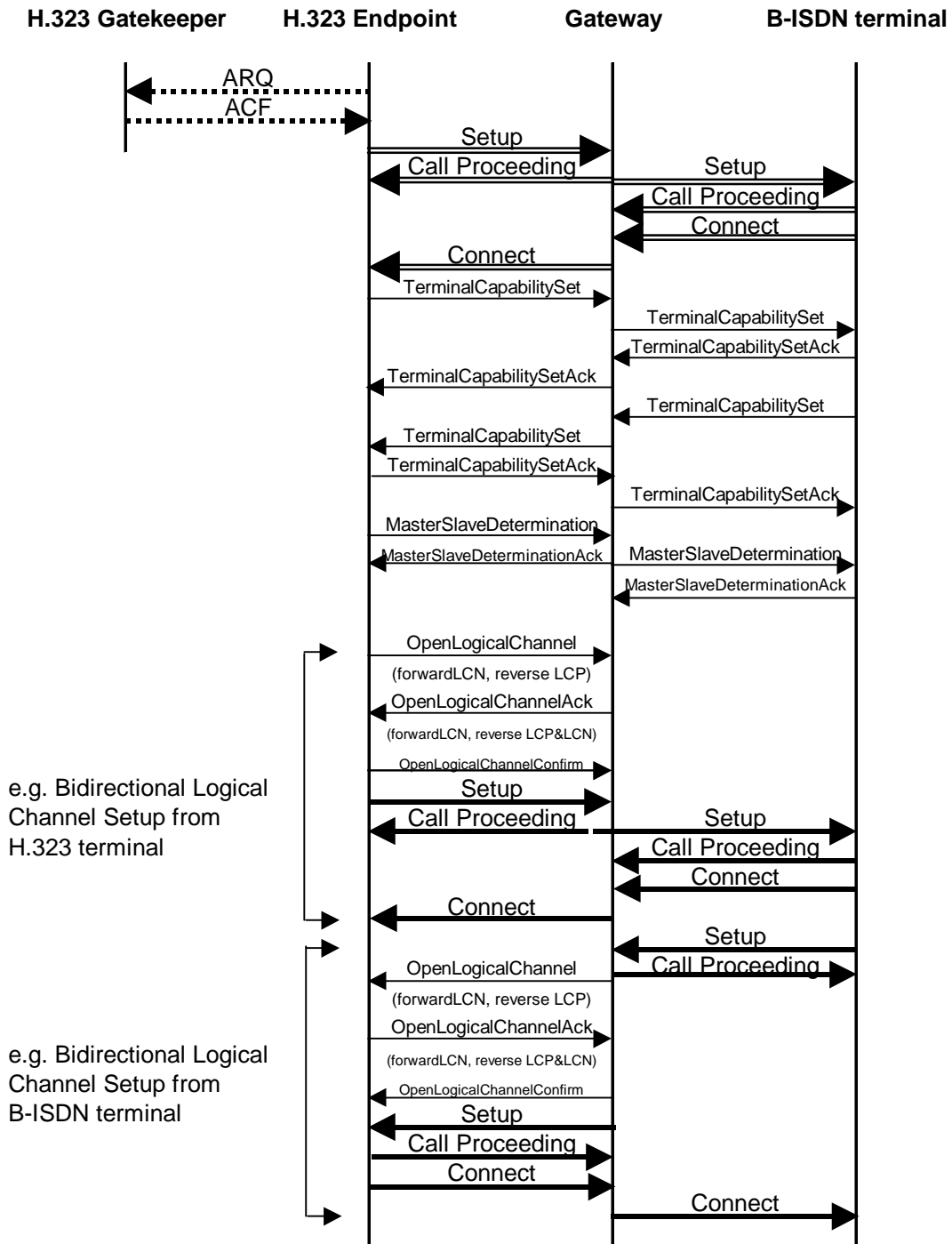

Figure 37 – Communication establishment from H.323 endpoint to B-ISDN separated call/bearer control environment in accordance with scenarios 2c

Communication establishment in the reverse direction as shown in figure 36.

8.7.5 Scenario 3c

Because scenario 3c is essentially H.323 annex C end-to-end, the call establishment sequence is not shown.

8.8 Generic functional protocol

The considerations in 7.9 for the separated B-ISDN environment apply also to the combined environment, with the exception of the statement concerning the use of the generic functional protocol for carrying the call control and pre-negotiation protocols.

8.9 Supplementary services

The considerations in 7.10 for the separated B-ISDN environment apply also to the combined environment, with the exception that references to call control should be replaced by references to call/bearer control. Also the statement concerning the application of supplementary services to the separated call and bearer control environment does not apply.

8.10 Conferencing

Further study is required.

8.11 Impact of T.120

Further study is required.

9 Summary of interworking scenarios in 7 and 8

Clauses 7 and 8 discuss H.323 interworking via a gateway with B-ISDN separated call and bearer control and with B-ISDN combined call/bearer control respectively, and the following scenarios are identified as applicable to each:

- 1 (sub-scenarios 1a, 1b and 1c);
- 2 (sub-scenarios 2a, 2b and 2c); and
- 3 (sub-scenario 3c only).

9.1 Scenario 1

For scenario 1, the gateway has to provide mapping between some elements of the H.323 session and resource control protocols and similar elements in the B-ISDN call control or combined call/bearer control protocol. Precise mappings require further study. The absence of session and resource control protocols in the B-ISDN mean that there is nothing to coordinate multiple calls. With separated call and bearer control in the B-ISDN, a single call can coordinate multiple bearers, and therefore support multimedia communications with one medium per bearer. With combined call and bearer control, a single call can have only a single bearer, and therefore this is not suitable for multimedia communications unless all media are multiplexed into the same bearer, as in H.310 or H.321. This may fail to exploit the different traffic characteristics of each medium. Thus separated call and bearer control has a distinct advantage in scenario 1.

9.2 Scenario 2

For scenario 2, the use of session and resource control protocols in the B-ISDN means that multiple calls can be coordinated, and therefore for combined call/bearer control, one call/bearer can be used per medium. For separated call/bearer control, there can be one call per medium (with a single bearer per call), one call with multiple bearers, or some combination of these. No particular advantage is gained from the use of separated call and bearer control.

The gateway provides interworking between the H.323 session/resource control protocols and the B-ISDN session/resource control protocols. If these are the same (e.g., H.323 session/resource control protocols re-used in B-ISDN), there is no interworking as such, although the gateway has to terminate the protocols in each environment and use information from these protocols to control interworking at the call and bearer levels. For sub-scenarios 2a and 2b, the gateway has to provide interworking between media stream transmission in the H.323 environment and the calls/bearers in the B-ISDN environment. For sub-scenario 2c, the gateway has to provide interworking between combined call/bearer control in the H.323 annex C environment and the form of call and bearer control in the B-ISDN environment. If this is combined call/bearer control too, then interworking at the call/bearer level becomes trivial, and if this is combined with the same session and resource control protocols in the two environments, the entire gateway becomes just a proxy linking two H.323 annex C environments.

The main issue with scenario 2 is the nature of the session and resource control protocols in the B-ISDN environment. H.323 session and resource control protocols can be used, or alternatively new protocols, perhaps based on the existing separated call control protocol with a revised set of object classes reflecting the session and resource control levels of the model. Further study is required to determine:

- whether existing H.323 session and resource control protocols are adequate for a B-ISDN environment;
- how is open logical channel used if H.245 is employed in the B-ISDN environment.
- whether session and resource control protocols for a B-ISDN environment can be based on the manipulation of objects identified at the session and resource control levels of the model;
- whether object classes used in such a session or resource control protocol can map to elements of the corresponding H.323 protocol for interworking purposes;
- whether session and resource control protocols can be combined in the B-ISDN environment, given the move to combine H.323 session and resource control protocols through fast set-up;
- if new session and resource control protocols are introduced for the B-ISDN environment, whether there would be any advantage in using these protocols also in the H.323 environment, replacing existing H.323 protocols.

9.3 Scenario 3

Scenario 3 can apply only in the case where ATM exists in the H.323 environment and H.323 annex C procedures are used (sub-scenario 3c). If separated call and bearer control is used in the B-ISDN environment, this is the only distinction between the two environments and the only function for the gateway to perform is interworking between separated and combined call/bearer control. The use of separated call and bearer control in the B-ISDN environment has the negative effect of introducing the need for this interworking function.

If combined call/bearer control is used in the B-ISDN environment, there is no distinction between the two environments and no gateway functions are required.

Assuming the end-to-end session and resource control protocols are the existing H.323 protocols, then scenario 3 is H.323 annex C end-to-end, except for the possible use of separated call and bearer control on part of the path. Alternatively new B-ISDN session and resource control protocols (as discussed under scenario 2 above) could be employed end-to-end.

10 Application of B-ISDN separated protocols to gatekeeper-to-gatekeeper communication

This topic requires further study.

11 Connection of remote H.323 environments via B-ISDN

There are basically two methods of using a B-ISDN to communicate between two IP networks:

1. Each IP network fully interworks with the B-ISDN and need not be aware that there is another IP network beyond the B-ISDN. This is similar to the “integrated scenario” concept for connecting two parts of a narrowband PISN via a public network.
2. Some or all of the control plane information between the two IP networks is “tunnelled” through the B-ISDN as user plane information or sent via another network (e.g., an IP network), the B-ISDN therefore not being aware of the content of this information. This is similar to the “overlay scenario” concept for connecting two parts of a narrowband PISN via a public network.

11.1 Case 1 – full interworking

For case 1, the two IP networks can interwork with the B-ISDN using any of the scenarios in clause 7 (separated call and bearer control in the B-ISDN) or any of the scenarios in clause 8 (combined call/bearer control in the B-ISDN). The same scenario must apply at both interworking points, although different sub-scenarios can be used.

11.2 Case 2 - tunnelling

For case 2, the IP network could be a native IP network or an IP over ATM network. Except where H.323 annex C is employed by the endstations, the only control plane protocols operating between the endstations are the H.323 session control and resource control protocols (H.225.0 “call control” and H.245

respectively). These can be tunnelled as a pair (scenario T1), just session control can be tunnelled (scenario T2) or just resource control can be tunnelled (scenario T3). In all cases, it is assumed that the originating endstation or its gatekeeper routes the session to a gateway that will act as the egress from the IP network to the B-ISDN network.

11.2.1 Scenario T1 - tunnelling of session and resource control protocols

The H.323 session and resource control protocols can be tunnelled through the B-ISDN or sent via a separate IP network (which could be IP over ATM).

11.2.1.1 Scenario T1.1 - tunnelling of session and resource control protocols through B-ISDN

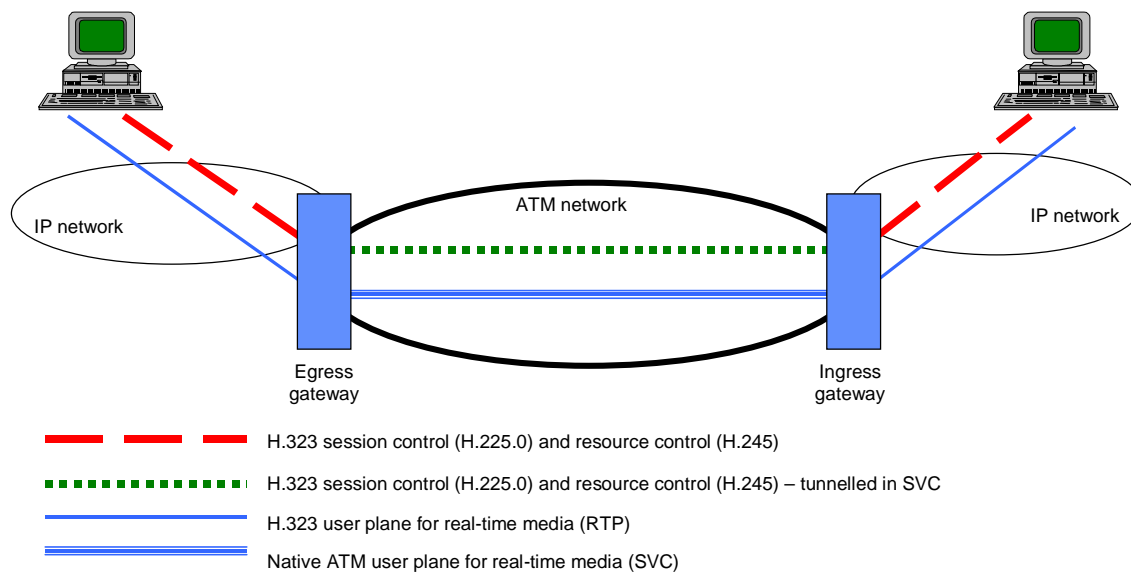

Figure 38 – Scenario T1.1

The egress gateway from the source IP network to the B-ISDN needs somehow to obtain an AESA with which it can establish an SVC to the peer gateway. This information could be provided by a server accessed by the gateway, or could be provided by the originating endstation or gatekeeper in the session control protocol.

Further study is required to determine how this relates to Study Group 16 work on inter-gatekeeper communication and the concepts of zones and domains.

The egress gateway from the source IP network establishes an SVC to the peer gateway, which is the ingress to the destination IP network. The H.323 session control protocol is then carried as user plane information within this SVC. Information within the session control protocol is then used to cause the resource control protocol to be carried within the same SVC (multiplexed or nested within the session control protocol) or in a separate SVC. H.323 annex C procedures within the resource control protocol provide the egress gateway with an AESA for establishing SVCs to the ingress gateway for carrying real-time media streams between the gateways.

This scenario would require enhancements to the H.323 session control protocol to allow the set-up of an H.245 channel across the ATM network and offers no real advantages over the case described below, assuming there is IP connectivity between the source and destination IP networks. In theory this can be solved by the use of an NSAP address (i.e., AESA) as the transport address, but further study is required on the feasibility of this (e.g., is it supported by H.323 implementations?)

11.2.1.2 Scenario T1.2 - transmission of session and resource control protocols through IP network, by-passing B-ISDN

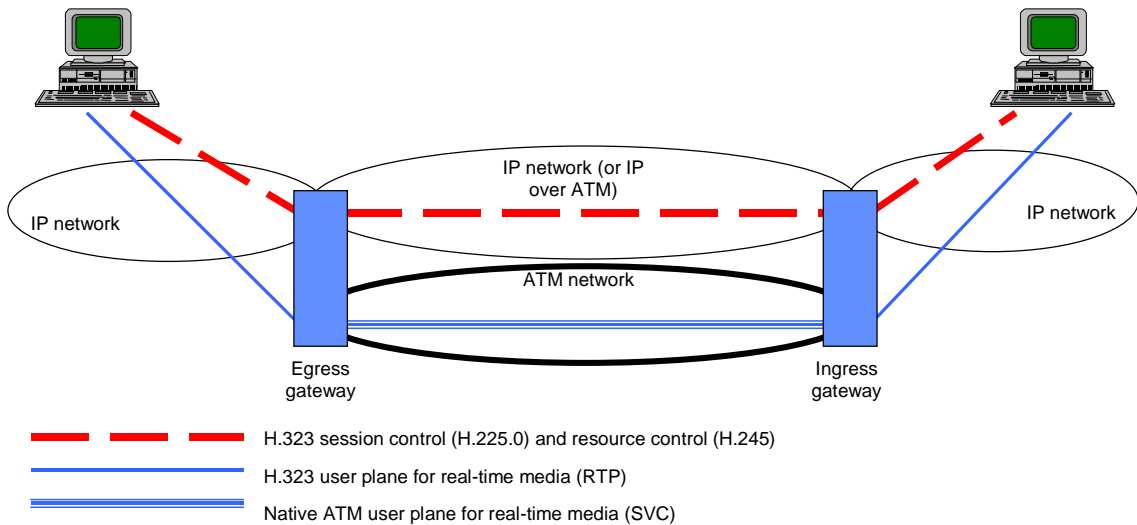

Figure 39 – Scenario T1.2

The egress gateway to the B-ISDN needs somehow to obtain an IP address of the ingress to the destination IP network. Normal IP routing is then used to establish the TCP connection to the ingress gateway for carrying the session control protocol. Normal H.323 procedures between the two gateways are used to establish a TCP connection for the resource control protocol. H.323 annex C procedures within the resource control protocol provide the egress gateway with an AESA for establishing SVCs to the ingress gateway for carrying real-time media streams between the gateways.

11.2.2 Scenario T2 - tunnelling of session control protocol only

The H.323 session control protocol can be tunneled through the B-ISDN or sent via a separate IP network (which could be IP over ATM). This implies the existence of a native B-ISDN resource control protocol. Since this is not the case at present, this scenario is not considered further.

11.2.3 Scenario T3 - tunnelling of resource control protocol only

The H.323 resource control protocol can be tunneled through the B-ISDN or sent via a separate IP network (which could be IP over ATM).

11.2.3.1 Scenario T3.1 - tunnelling of resource control protocol through B-ISDN

This assumes either the use of a native ATM session control protocol or dispensing with session control. In the absence of a native ATM session control protocol at present, it is assumed here that a dedicated session control protocol is dispensed with.

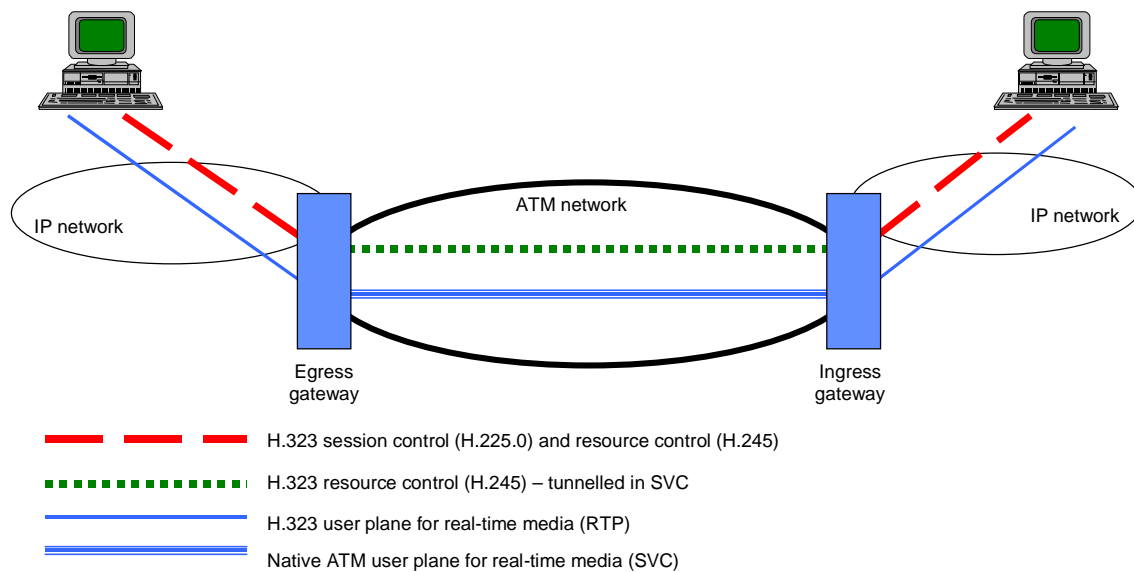

Figure 40 – Scenario T31.1

The egress gateway to the B-ISDN needs somehow to obtain an AESA with which it can establish an SVC to the peer gateway. This information could be provided by a server accessed by the gateway, or could be provided by the originating endstation or gatekeeper in the session control protocol.

The egress gateway establishes an SVC to the peer gateway, which is the ingress to the destination IP network. The H.323 resource control protocol is then carried as user plane information within this SVC. H.323 annex C procedures within the resource control protocol provide the egress gateway with an AESA for establishing SVCs to the ingress gateway for carrying real-time media streams between the gateways.

Note that the call/bearer control protocols used to establish the SVC for resource control effectively act as a basic session control protocol. They could also carry session-level supplementary service information.

11.2.3.2 Scenario T3.2 - transmission of resource control protocol through IP network, by-passing B-ISDN

This implies the existence of a native B-ISDN session control protocol that is able to establish a TCP connection for carrying the H.323 resource control protocol (H.245). Since this is not currently the case, this is not a practical scenario at present and is not considered further.

11.2.4 Additional considerations when endstations employ H.323 annex C (native IP network or IP over ATM network)

In any of the scenarios described in above, it can emerge at open logical channel time that the two endstations are connected to ATM networks and support H.323 annex C procedures. The ingress and egress gateways can each (independently) choose either:

- to force SVCs for real-time media to be routed through the gateway, in which it will originate and terminate logical channels and use its own AESA for SVC establishment; or
- to allow SVCs for real-time media to by-pass the gateway, in which the gateway will pass on open logical channel messages with AESAs unchanged.

11.2.5 Conclusions on tunnelling scenarios

Scenarios that appear to be of some practical value are scenarios T1.2 and T3.1 (the latter using the B-ISDN call control protocol as the session layer protocol between gateways).

NOTE

Scenario T1.1 may also be of practical value, depending on whether enhancing the session control protocol can be avoided, perhaps by using the NSAP transport address.

Scenario T1.2 just routes real-time media streams through the B-ISDN network, thereby achieving quality gains on what potentially can be a long haul with significant delays if an IP network were used instead. It is essentially this scenario that is being pursued by the ATM Forum SAA/RMOA group. Note that if the endstations employ H.323 annex C procedures, this scenario becomes trivial – effectively it is H.323 (with annex C) end-to-end, with the real-time media stream SVCs optionally being routed via the gateways.

In a pure tunnelling context, scenario T3.1 offers only marginal benefits over scenario T1.2, in that an SVC is used to carry H.245. However, further benefits arise if the egress gateway is unaware of whether the destination (as defined by the AESA it is to use for routing in the B-ISDN) is a native ATM destination or a destination on another IP network. If SVC establishment encounters an ingress gateway, the two gateways could agree to use scenario T3.1.

12 Co-existence of H.323 annex C and B-ISDN signalling in the same network

In an ATM network that supports both H.323 endpoints using H.323 annex C and native B-ISDN endpoints, the boundary between the H.323 environment and the B-ISDN environment becomes indistinct. Further study is required to determine when H.323 protocols are used and when B-ISDN protocols are used to reach a given destination.

13 Impact of H.323 on future mobility protocols

13.1 Introduction

Most first offerings on mobility have concentrated on location registration, authentication, delivery of incoming calls and allowing the user to make outgoing calls. They have performed this using the concept of home location and visited location servers within the network. Such architectural concepts are used today even with more advanced thinking.

Having provided such basic capabilities, the issue of subscription and privileges is now addressed. In early days this was achieved by passing around a service class, indicating which services the user was entitled to. The services available in the local exchange of the visited network are then provided to the visiting user if he is allowed to have them. IN early GSM, this is one reason for the strong insistence on common service offerings from all network operators, with a strongly defined set of supplementary services.

With distinct service offerings now being regarded as of commercial importance in discriminating the offerings of different network providers, it has now become essential to offer the service as seen by the home network, rather than just the privilege of using a common service for which the subscription exists in the home network. This has led to the development of a concept called virtual home environment (VHE) which is described in a later subclause.

13.2 Mobility concepts

Mobility provides for both:

- terminal mobility: this allows the terminal personal to the user to be used in different networks. For terminal mobility, the terminal is frequently attached using radio communication.
- personal mobility, where the user is mobile, but borrows a terminal that is already attached to the visited network infrastructure, and which normally belongs to another user who has his own subscription. This concept is known as Universal Personal Telecommunications (UPT) for public networks and Private Personal Mobility (PPM) for PISNs.

For both the above, users have:

- a subscription to a network operator;
- a set of services provided by that operator.

These should appear to the user, no matter what terminal or network the user is physically using.

NOTE

In addition, number portability is being addressed between different network operators in both ETSI and ITU-T. This could be envisaged as subscription mobility. In this case the number is ported to a different network; in this case services should not be ported, and the user should expect to get a completely new set of services that go with his new network subscription.

For terminal mobility, roaming can occur even during a call. Personal mobility and terminal mobility can occur in combination.

13.3 Mobility architecture

Figure 41 shows the current functional architecture for IMT-2000 where the functional elements constituting the family concept are specified. Any mobility offering should fall into one of these functional groupings, so that mobility concepts in different family members can be offered across different network infrastructures. Thus it should be possible for a mobility user based within an H.323 environment to receive mobility service (not necessarily at his own terminal) in a B-ISDN mobility environment.

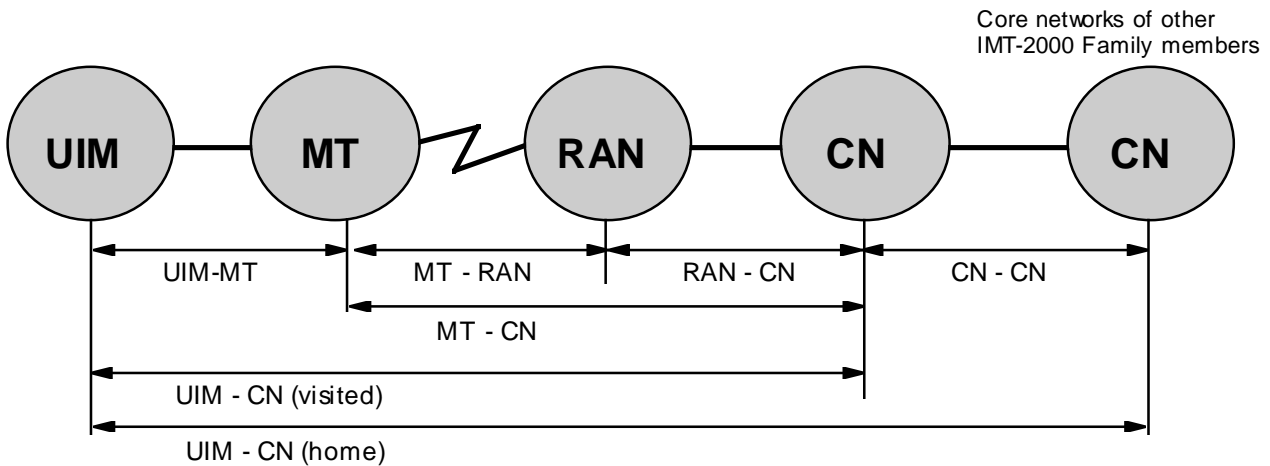

Figure 41 – IMT2000 family model (functional architecture)

In this figure, the following terminology applies:

- UIM is the User Identity Module. This can either be integrated within the terminal or be a separate plug in unit or card. It contains functionality specific to the subscriber rather than the terminal, and thus, as well as its fundamental role of containing subscriber identifiers, could also act as an environment for supporting subscriber specific services.
- MT is the Mobile Terminal. This provides support of the terminal radio aspects, and can also play a role in providing services to the end user.
- RAN is the Radio Access Network. This provides all the radio specific parts of the visited system, and concentrates traffic to the visited core network. As such it handles functions such as diversity, local (“soft”) handover, and radio channel management.
- CN is the Core Network. This provides the switching environment for basic services requested by the end user, and also provides a platform for service provision. Two important CNs are identified, these are:
 - the visited CN, which provides the access of the user to a network infrastructure, and therefore supports requests from the user for mobility management, relays these requests on to the home CN and provides such basic services if the mobility management is valid; and
 - the home CN, which supports the registration and subscription of users, and therefore acts as the peer entity in any mobility management protocol.

In order to support mobility (roaming) in the future between different environments, a common reference model needs to exist in both environments. The model for IMT-2000 described in ITU-T Recommendation Q.1701 provides the basis for this by allowing each environment to develop as a separate IMT-2000

family member, and provide one or more of the family member functions identified above. These family member functions will communicate by a defined and standardised interface, but within the family member they are at liberty to use their own protocols specific to that environment.

The family model for IMT-2000 should therefore be used as the basis for interoperability of mobility between a B-ISDN environment and an H.323 environment, which means that any mobility defined separately for these environments, must also be based on this model.

Ongoing work in ITU-T Study Group 11 and in the new ETSI 3rd generation partnership project will probably identify B-ISDN as a candidate (but not necessarily only) switching environment for IMT-2000 family members. As such, either a combined or separated call/bearer control protocol can be expected to develop associated mobility management concepts. It is unlikely that any B-ISDN mobility solutions will be developed outside the IMT-2000 family model, although how the work within the ATM forum (WATM group) relates to IMT-2000 is unclear at this stage and requires further study.

Mobility is being identified as of interest by the developers of the H.323 protocols, but as yet, discussions are at an early stage, and the IMT-2000 model has not yet occurred within those discussions.

It is recommended that any mobility concepts within the H.323 environment is developed based on IMT-2000 family member concepts, as specified in ITU-T Recommendations Q.1701 and Q.1711.

13.4 Virtual Home Environment (VHE)

VHE is defined as service portability across network boundaries and terminals. Service software in the terminal and appropriate network locations is used to offer the service. This service software may be permanently resident in those locations, or may be created elsewhere and delivered to those locations.

A generic architecture for VHE may look as shown in figure 42.

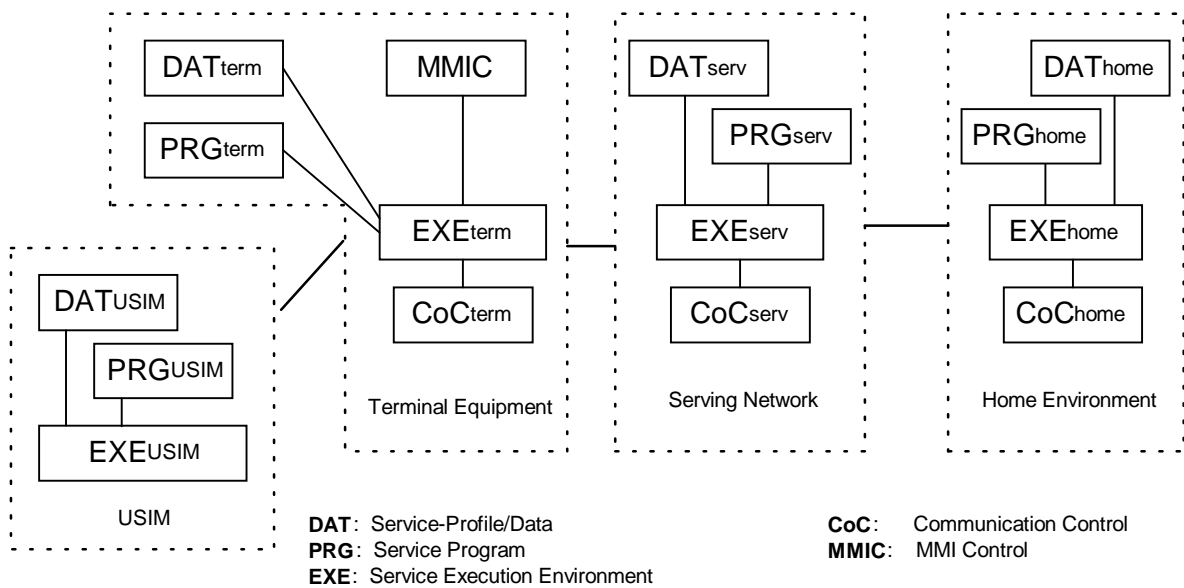

Figure 42 – GSM architecture for virtual home environment

The main functional blocks in the figure relate to the ITU-T Recommendation Q.1701 functional blocks as follows:

User Subscriber Identify Module (USIM)	User Identify Module (UIM)	
Terminal equipment	Mobile Terminal (MT)	
Serving Network	Core Network (CN) visited	
Home Environment	Core Network (CN) home	The GSM environment brings out that the home network does not need to provide any switching support of various bearer capabilities, and therefore does not need to be a telecommunications network in the traditional sense.

The service may be executed in any combination of locations

- UIM
- TE
- home core network
- visited core network

Flexible provision of services can be obtained by allowing one entity to download software to another entity, or by one entity instructing another entity on how to perform a particular service, providing relevant agreements and constraints exist on how this can occur.

VHE allows flexible provision of services by the home core network to the terminal by the use of such capabilities, including (among others):

- the ability to download software to the UIM in order to “create” new services in the terminal.
- the ability of the home core network to instruct the visited core network on how to provide the service. Various mechanisms are envisaged for the support of this capability, particularly when IN is involved.

Further information can be found in documentation from ETSI SMG and from working group NA6 (currently dr-EG/NA-061301).

It is recommended that future service development for the separated call/bearer B-ISDN environment, the combined call/bearer B-ISDN environment, and the H.323 environment should concentrate on providing VHE concepts for the provision of services, and on allowing these concepts to interwork.

For all environments, these concepts should include intelligent networking, computer telephony integration and intelligent proxy servers, and the ability to interwork between them.

14 Conclusions and recommendations

This Technical Report identifies a number of scenarios for:

- interworking between an H.323 environment and a B-ISDN separated call and bearer control environment (clause 7, with summary in clause 9);
- interworking between an H.323 environment and a B-ISDN combined call/bearer control environment (clause 8, with summary in clause 9);
- connection of remote H.323 environments via B-ISDN (11).

Other topics such as the impact of mobility are also mentioned.

Based on information in this report, it should be possible to assess which of the scenarios are worth developing further from a standardization point of view.

During work on this report, there was insufficient time to investigate every issue identified, and therefore there are many places throughout the report where specific items are mentioned as requiring further study. These are listed in table 1.

Table 1 – Topics identified for potential further study

Topic for further study	Clause
Further standardization of selected interworking scenarios	9
Further standardization of selected tunnelling scenarios.	11.2
For scenario 3a, the use of gatekeepers and the RAS protocol in the B-ISDN environment requires further study.	7.2.3.1 and 8.2.3.1
For scenario 2, are there capabilities in H.245 that are not used by H.323 but may be applicable in a B-ISDN environment.	7.4
For scenario 2, would a new resource group protocol need to encompass the concept of resource groups?	7.4
The feasibility of using an NSAP address (i.e., AESA) as an alias.	7.7.1 and 7.7.3
Taking into account the work of other bodies on the subject of addressing (e.g., the IETF E.164 Birds of a Feature activity, TIPHON, NA2) and assessing the impact on addressing of call/bearer separation.	7.7.3
For scenario 2, how is open logical channel used if H.245 is employed in the B-ISDN environment.	7.8.3, 7.8.4, 8.7.3, 8.7.4 and 9.2
Can supplementary services operate transparently between the two environments using an enhanced GFT-Control, as currently being progressed in ITU-T Study Group 11 and ETSI SPS5 WG5, taking into account issues such as the different entity types in the two environments, Network Facility Extension addressing values and encoding rules?	7.9
Despite the common QSIG basis, does H.323 put a different complexion on requirements for supplementary services?	7.10.5
How can supplementary services be applied to the separated call and bearer control environment?	7.10.5
What supplementary services are candidates for interworking between H.323 and B-ISDN (separated or combined call/bearer control environments)?	7.10.5 and 8.9
The impact of conferencing.	7.11 and 8.10
The impact of T.120 data.	7.12 and 8.11
Precise mappings for scenario 1 between some elements of the H.323 session and resource control protocols and similar elements in the B-ISDN call control or combined call/bearer control protocol.	9.1
For scenario 2, whether existing H.323 session and resource control protocols are adequate for a B-ISDN environment.	9.2
For scenario 2, whether session and resource control protocols for a B-ISDN environment can be based on the manipulation of objects identified at the session and resource control levels of the model.	9.2
Whether object classes used in such a session or resource control protocol can map to elements of the corresponding H.323 protocol for interworking purposes.	9.2
For scenario 2, whether session and resource control protocols can be combined in the B-ISDN environment, given the move to combine H.323 session and resource control protocols through fast set-up.	9.2

For scenario 2, if new session and resource control protocols are introduced for the B-ISDN environment, whether there would be any advantage in using these protocols also in the H.323 environment, replacing existing H.323 protocols.	9.2
Application of B-ISDN separated protocols to gatekeeper-to-gatekeeper communication.	10
For tunnelling scenario T1.1 how to obtain an AESA for establishing an SVC to the peer gateway, and whether this relates to Study Group 16 work on inter-gatekeeper communication and the concepts of zones and domains.	11.2.1.1
The feasibility of using an NSAP address (i.e., AESA) as the transport address for establishing an H.245 channel for tunnelling scenario T1.1.	11.2.1.1
In a mixed H.323 / B-ISDN environment, when are H.323 protocols used and when are B-ISDN protocols used to reach a given destination?	12
How does the work within the ATM forum (WATM group) relate to IMT-2000?	13.3

Printed copies can be ordered from:

ECMA

114 Rue du Rhône
CH-1204 Geneva
Switzerland

Fax: +41 22 849.60.01

Internet: documents@ecma.ch

A description of this Technical Report can be found on the ECMA Web site, www.ecma.ch. From there, files T073-DOC.EXE (MSWord, self-expanding) and T073-PDF.PDF (Acrobat PDF) can be freely downloaded.

The ECMA web site gives full information on ECMA, ECMA activities, ECMA Standards and Technical Reports.

ECMA

**114 Rue du Rhône
CH-1204 Geneva
Switzerland**

This Technical Report ECMA TR/73 is available free of charge in printed form and as a file.

See inside cover page for instructions